

Figure 1. Physical Photos of AHVR15V4KV2R5MAP

FEATURES

- Output Voltage Proportional to Input Voltage
• Output Voltage from 0 to 4000V
• Input Voltage from 0V to 15V
• Low Power Consumption
• High Efficiency
• High Stability
• Low Turn-on Voltage 0.7VDC
• Input to Output Isolation
• Small Output Ripple, Time Drift, and Temperature Drift
• Overload and Short Circuit Protection
• Metal Enclosure for Zero EMIS
• Easy Control and Installation

APPLICATIONS

This power module, AHVR15V4KV2R5MAP, is designed for achieving DC-DC conversion from low voltage to high voltage as a power supply source. It can be used for:

- X-ray Machine
• Spectral Analysis
• Nondestructive Inspection
• Semiconductor Manufacturing Equipment
• Capillary Electrophoresis
• Physical Vapor Phase Deposition
• Electrospinning Preparation of Nanofiber
• DC Reactive Magnetron Sputtering

Table 1. Pin Names, Functions and Specifications

Table with 7 columns: No., Name, Description, Type, Min., Typ., Max. and 5 rows of pin specifications.



DESCRIPTION

AHVR15V4KV2R5MAP comes with a quasi-sine wave oscillator, a fully enclosed transformer, an input and output filter, and a five-sided metal enclosure. These modules present low EMI/RFI, low noise, and low ripple. The input and output are galvanically isolated. Proportional to the input voltage, the output voltage has a typical turn-on voltage as low as 0.7V. It also comes with output short-circuit protection and a wide range of output voltage adjustments. This high voltage power supply also features ultra-small size, light weight, moisture proof, shockproof, metal enclosure, and zero EMIs.

USING AHVR15V4KV2R5MAP

This high voltage power supply must be mounted tightly onto a metal plate, ideally, thus expanding its heating sinking capacity of the metal enclosure. Sufficient ventilation must be provided to keep the power supply surface temperature under 55°C.

SAFETY PRECAUTIONS

Although AHVR15V4KV2R5MAP high voltage power supply comes with an over current protection circuit, a short circuit at the output should always be avoided. Make sure the high voltage wire for connecting VOUT node has sufficient insulation capability with its surrounding objects.

BLOCK DIAGRAM

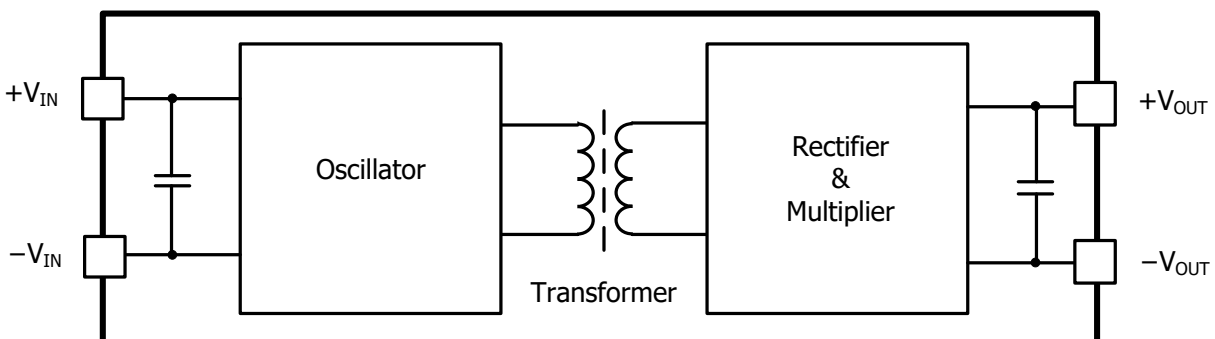

Figure 4. Block Diagram

APPLICATION NOTES

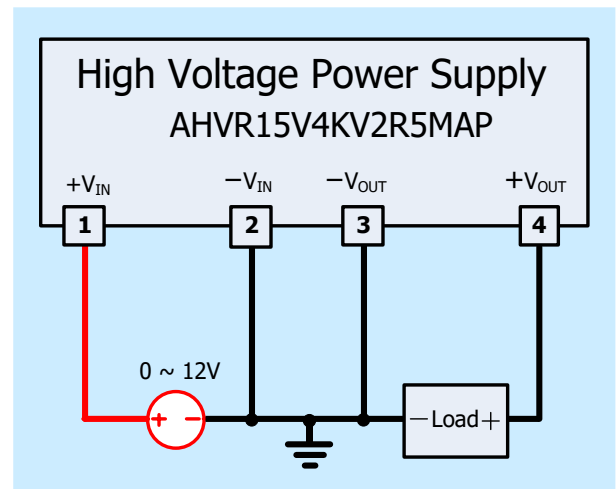

Figure 2. Positive Output

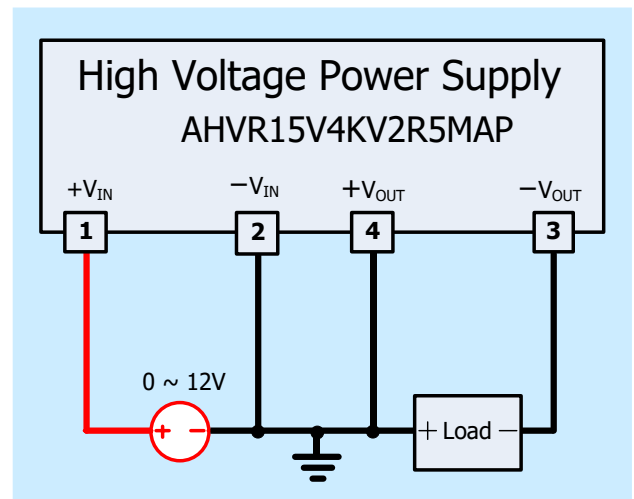

Figure 3. Negative Output



SPECIFICATIONS

Table 2. Characteristics. T_A = 25°C, unless otherwise noted.

Parameter	Symbol	Test Conditions	Min.	Typ.	Max.	Unit/Note
Input Power Supply Voltage	V _{IN}		0		15	V
Input Power Supply Quiescent Current	I _{VPS_QC}	I _{VOUT} = 0mA	400	500	600	mA
Input Power Supply Current at Full Load	I _{VPS_FL}	I _{VOUT} = 2.5mA	1.4	1.5	1.6	A
Output Voltage Range	V _{VOUT}	I _{VOUT} = 0 ~ 2.5mA	0		4000	V
Output Current Range	I _{VOUTMAX}	V _{IN} = 12V	0		2.5	mA
Output Load Resistance Range			$\frac{V_{VOUT}}{I_{VOUT}}$		∞	MΩ
Output Voltage Tolerance		At Max V _{OUT} , Full Load			±5	%
Output Voltage Ripple	V _{VOUT_RP}	R _{LOAD} = 1.6MΩ V _{VOUT} = 4000V	≤1			V _{P-P}
Response Time	t _{RESPONSE}	0 to Max V _{OUT} , Full Load		260		ms
Isolation Voltage: Input to Output				3500		V
Switching Frequency	F _{SW}		25		125	kHz
Full Load Efficiency	η	V _{VPS} = 12V V _{VOUT} = 4000V I _{VOUT} = 2.5mA		≥70		%
Output Voltage Temperature Stability		-20 ~ 50°C			±1	%
Operating Temperature Range	T _{opr}		-10		70	°C
Storage Temperature Range	T _{stg}		-25		90	°C
Humidity		Non-condensing		95		%RH
External Dimensions			71.1×43.2×21.6			mm
			2.80×1.70×0.85			inch
Weight				145		g
				0.32		lbs
				5.11		Oz



TESTING DATA

Test conditions: $V_{PS} = 12V$, $T_A = 25^\circ C$, $R_{LOAD} = 1.6M\Omega$

The measured output voltage, V_{OUT} , corresponding to the input voltage, V_{IN} , is shown in Figure 7.

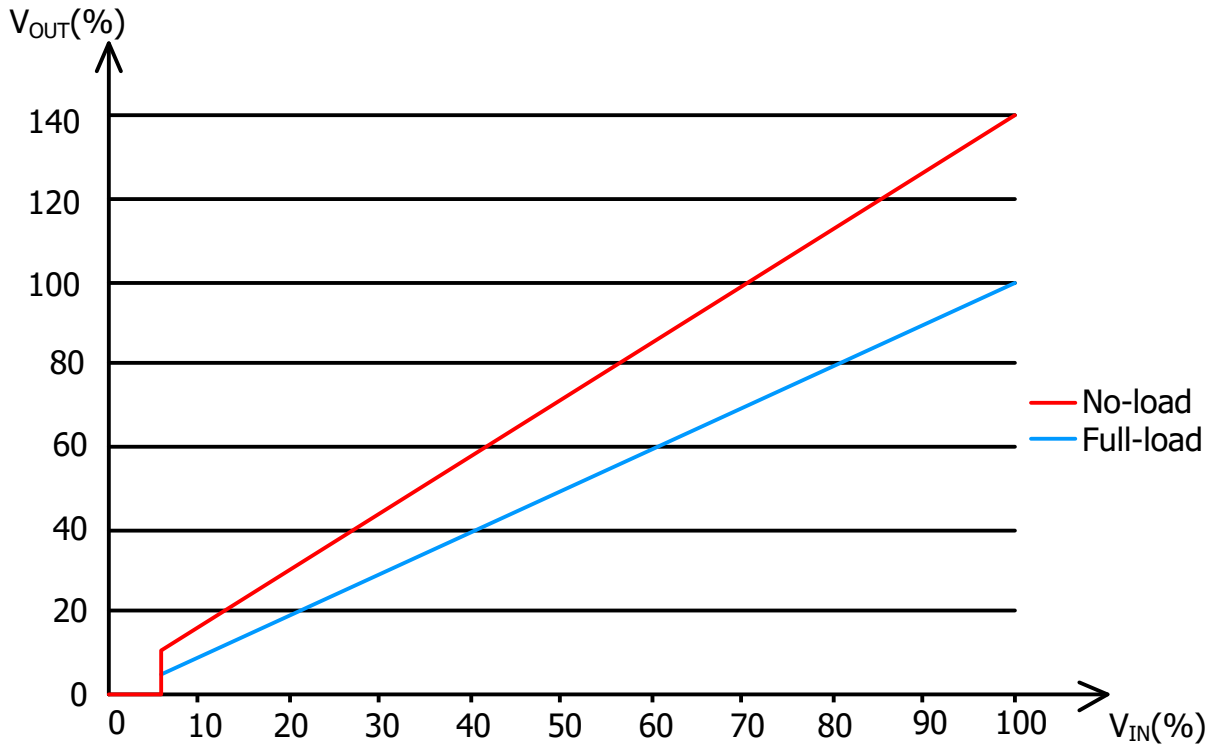

Figure 5. V_{IN} vs. V_{OUT}

NAMING PRINCIPLE

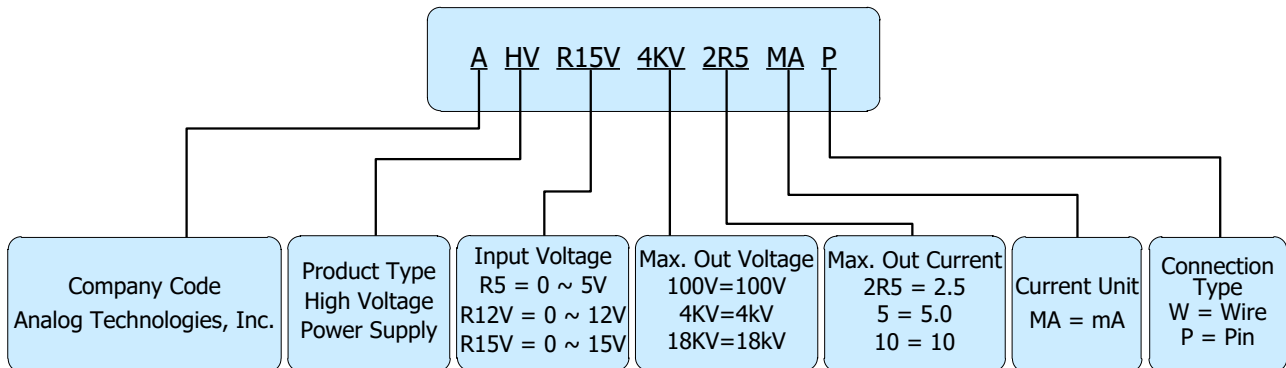

Figure 6. Naming Principle of AHVR15V4KV2R5MAP



DIMENSIONS

Pin Layout

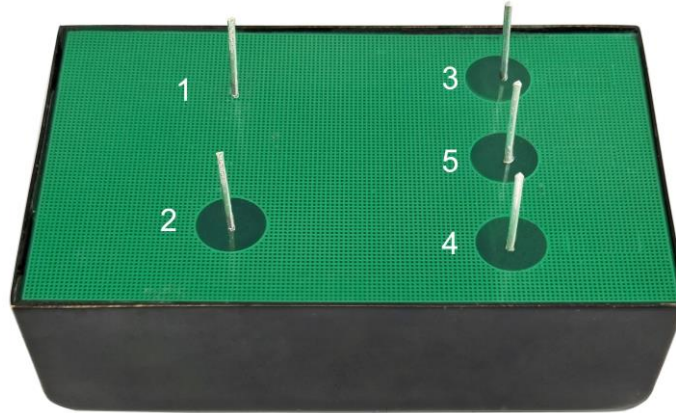

Figure 7. Pin Layout for AHVR15V4KV2R5MAP

Outline Dimensions

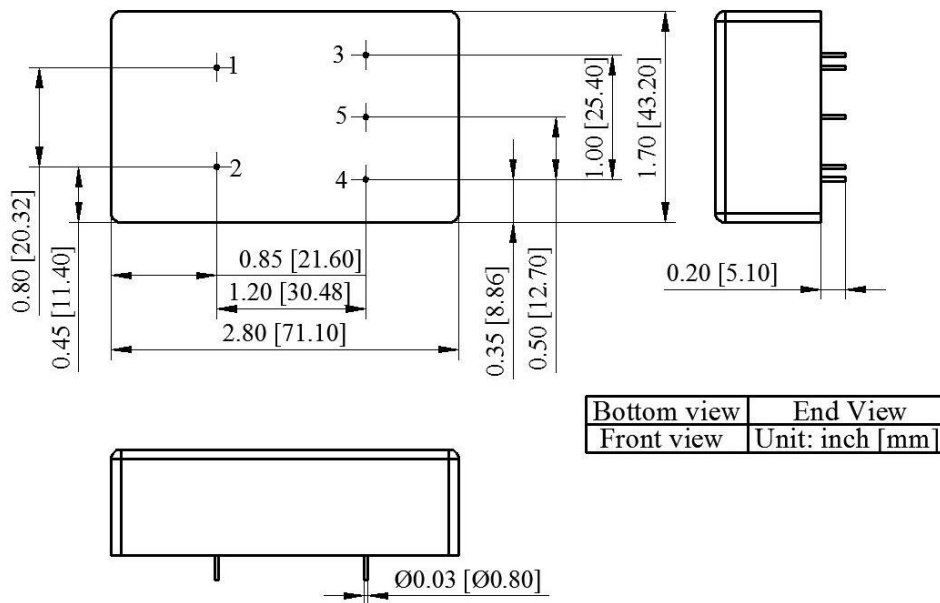

Figure 8. Outline Dimensions

ORDERING INFORMATION

Part Number	Buy Now
AHVR15V4KV2R5MAP	* *

*: both and are our online store icons. Our products can be ordered from either one of them with the same pricing and delivery time.



RELATED PRODUCTS

Part #	Datasheet	Output Type	Output Voltage (V)	Output Current (mA)	Input Voltage (V)	Ripple (%)	Buy Now*
AHVR12V100V100MAP	Contact Us	Single Output	0 ~ 100 or 0 ~ -100	100	0 ~ 12	<0.6	Contact Us
AHVR12V100V50MAP2	Contact Us	Dual Output	0 ~ ±100	50	0 ~ 12	<1.0	Contact Us
AHVR12V200V50MAP	Contact Us	Single Output	0 ~ 200 or 0 ~ -200	50	0 ~ 12	<1.0	Contact Us
AHVR12V300V33R3MAP	Contact Us	Single Output	0 ~ 300 or 0 ~ -300	33.3	0 ~ 12	<1.0	Contact Us
AHVR12V150V33R3MAP2	Contact Us	Dual Output	0 ~ ±150	33.3	0 ~ 12	<1.0	Contact Us
AHVR12V400V25MAP	Contact Us	Single Output	0 ~ 400 or 0 ~ -400	25	0 ~ 12	<1.0	Contact Us
AHVR12V200V25MAP2	Contact Us	Dual Output	0 ~ ±200	25	0 ~ 12	<1.0	Contact Us
AHVR12V500V20MAP		Single Output	0 ~ 500 or 0 ~ -500	20	0 ~ 12	<1.0	*
AHVR12V600V16MAP	Contact Us	Single Output	0 ~ 600 or 0 ~ -600	16	0 ~ 12	<1.0	Contact Us
AHVR12V300V25MAP2	Contact Us	Dual Output	0 ~ ±300	16	0 ~ 12	<1.0	Contact Us
AHVR12V800V12R5MAP	Contact Us	Single Output	0 ~ 800 or 0 ~ -800	12.5	0 ~ 12	<1.0	Contact Us
AHVR12V1KV10MAP		Single Output	0 ~ 1000 or 0 ~ -1000	12.5	0 ~ 12	<1.0	*
AHVR12V500V10MAP2	Contact Us	Dual Output	0 ~ ±500	10	0 ~ 12	<1.0	Contact Us
AHVR12V1200V8R3MAP	Contact Us	Single Output	0 ~ 1200 or 0 ~ -1200	8.3	0 ~ 12	<1.0	Contact Us
AHVR12V600V8R3MAP2	Contact Us	Dual Output	0 ~ ±600	8.3	0 ~ 12	<1.0	Contact Us
AHVR12V1500V6R6MAP	Contact Us	Single Output	0 ~ 1500 or 0 ~ -1500	6.6	0 ~ 12	<1.0	Contact Us
AHVR12V750V6R6MAP2	Contact Us	Dual Output	0 ~ ±750	6.6	0 ~ 12	<1.0	Contact Us
AHVR12V2KV5MAP		Single Output	0 ~ 2000 or 0 ~ -2000	5	0 ~ 12	<1.0	*
AHVR15V3KV3R3MAP		Single Output	0 ~ 3000 or 0 ~ -3000	3.3	0 ~ 15	<1.0	*
AHVR15V1500V3R3MAP2	Contact Us	Dual Output	0 ~ ±1500	3.3	0 ~ 15	<1.0	Contact Us
AHVR15V4KV2R5MAP		Single Output	0 ~ 4000 or 0 ~ -4000	2.5	0 ~ 15	<1.0	*
AHVR15V2KV2R5MAP2	Contact Us	Dual Output	0 ~ ±2000	2.5	0 ~ 15	<1.0	Contact Us
AHVR15V5KV2MAP		Single Output	0 ~ 5000 or 0 ~ -5000	2.0	0 ~ 15	<1.0	*
AHVR15V2500V2MAP2	Contact Us	Dual Output	0 ~ ±2500	2.0	0 ~ 15	<1.0	Contact Us
AHVR15V6KV1R66MAP	Contact Us	Single Output	0 ~ 6000 or 0 ~ -6000	1.66	0 ~ 15	<1.0	Contact Us
AHVR15V3KV2MAP2	Contact Us	Dual Output	0 ~ ±3000	1.66	0 ~ 15	<1.0	Contact Us
AHVR15V8KV1R25MAP	Contact Us	Single Output	0 ~ 8000 or 0 ~ -8000	1.25	0 ~ 15	<2.5	Contact Us
AHVR15V4KV1R25MAP2	Contact Us	Dual Output	0 ~ ±4000	1.25	0 ~ 15	<2.5	Contact Us
AHVR15V10KV1MAP	Contact Us	Single Output	0 ~ 10000 or 0 ~ -10000	1.25	0 ~ 15	<2.5	Contact Us
AHVR15V12KVR83MAP	Contact Us	Single Output	0 ~ 12000 or 0 ~ -12000	0.83	0 ~ 15	<2.5	Contact Us
AHVR15V6KV83MAP2	Contact Us	Dual Output	0 ~ ±6000	0.83	0 ~ 15	<2.5	Contact Us



NOTICE

1. ATI warrants performance of its products for one year to the specifications applicable at the time of sale, except for those being damaged by excessive abuse. Products found not meeting the specifications within one year from the date of sale can be exchanged free of charge.
2. ATI reserves the right to make changes to its products or to discontinue any product or service without notice, and advise customers to obtain the latest version of relevant information to verify, before placing orders, that the information being relied on is current and complete.
3. All products are sold subject to the terms and conditions of sale supplied at the time of order acknowledgment, including those pertaining to warranty, patent infringement, and limitation of liability. Testing and other quality control techniques are utilized to the extent ATI deems necessary to support this warranty. Specific testing of all parameters of each device is not necessarily performed, except those mandated by government requirements.
4. Customers are responsible for their applications using ATI products. In order to minimize risks associated with the customers' applications, adequate design and operating safeguards must be provided by the customers to minimize inherent or procedural hazards. ATI assumes no liability for applications assistance or customer product design.
5. ATI does not warrant or represent that any license, either express or implied, is granted under any patent right, copyright, mask work right, or other intellectual property right of ATI covering or relating to any combination, machine, or process in which such products or services might be or are used. ATI's publication of information regarding any third party's products or services does not constitute ATI's approval, warranty or endorsement thereof.
6. IP (Intellectual Property) Ownership: ATI retains the ownership of full rights for special technologies and/or techniques embedded in its products, the designs for mechanics, optics, plus all modifications, improvements, and inventions made by ATI for its products and/or projects.