

# SPECIFICATION CONTROL DRAWING

THIS DRAWING CONTAINS INFORMATION PROPRIETARY TO RF INDUSTRIES, LTD. ANY UNAUTHORIZED USE OF THIS DRAWING IS EXPRESSLY PROHIBITED. ANY VIOLATION IS PUNISHABLE UNDER U.S. COPYRIGHT LAWS.

REV	DESCRIPTION	DWN	DATE	APPROVED
A	ENGINEERING RELEASE	CZS	8/18/98	K. MAXWELL

ALL DIMENSIONS ARE REFERENCE ONLY

000494

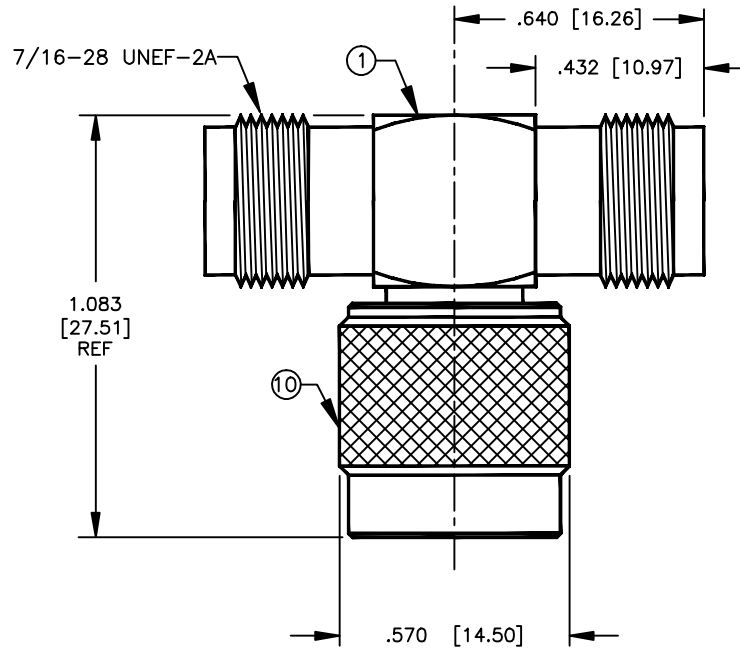

## SPECIFICATIONS:

IMPEDANCE: 50 OHMS  
 WORKING VOLTAGE: 500 VRMS @ SEA LEVEL  
 FREQUENCY RANGE: 0-7 GHz

ITEM	DESCRIPTION	QTY	MATERIAL	FINISH
10	SHELL	1	BRASS	NICKEL
9	RETAINING RING	1	BRASS	NONE
8	GASKET	1	S.I. RUBBER	RED
7	PRESS FIT WASHER	1	BRASS	NICKEL
6	DIELECTRIC	1	PTFE	NONE
5	DIELECTRIC	2	PTFE	NONE
4	PIN	1	BRASS	GOLD
3	CONTACT	1	BRASS	GOLD
2	PRESS FIT BODY	1	BRASS	NICKEL
1	BODY	1	BRASS	NICKEL

DIMENSIONS ARE IN INCHES AND [MILLIMETERS]

UNLESS OTHERWISE NOTED TOLERANCES ARE:  
 DECIMALS DIAMETER

DRAWN C. ZUNIGA 8/18/98

CHECKED

ORJ DRAWN C. ZUNIGA 8/18/98

APPROVALS DATE

**RFconnectors**  
 DIVISION OF RF INDUSTRIES, LTD.

7610 MIRAMAR RD  
 SAN DIEGO, CA 92126  
 (619)549-6340  
 (619)549-6345 FAX

**RFT-1228**

TNC "T" ADAPTER F-M-F

SIZE	CABLE GROUP	DWG NO.	REV
A	N/A	8956	A

SCALE: 2:1 CAD FILE 13ARC B SHEET 1 OF 1