

# **QT-Brightek PLCC2 Series**

## **PLCC2 White LED**

**Part No.: QBLP670-IW**

---

**Table of Contents:**

Introduction .....	3
Electrical / Optical Characteristic (Ta=25 °C) .....	4
Absolute Maximum Rating .....	4
Correlated Color Temperature Chart .....	5
Characteristic Curves.....	6
Solder Profile & Footprint.....	7
Packing .....	8
Labeling .....	9
Ordering Information .....	9
Disclaimer .....	10

## Introduction

**Feature:**

- Package in tape and reel
- Ultra bright reflector type PLCC2 LED
- InGaN technology for White
- Yellow diffused lens
- Viewing angle: 120 deg typ.

**Description:**

These ultra bright reflector type PLCC2 LEDs have a height profile of 1.90mm. With a combination of high brightness output and robust package, these LEDs are ideal for architecture lighting, status indication, and industrial equipment lighting applications.

**Application:**

- Status indication
- Equipment backlighting
- Interior lighting
- Household equipment lighting

**Certification & Compliance:**

- ISO9001
- RoHS Compliant



**Dimension:**

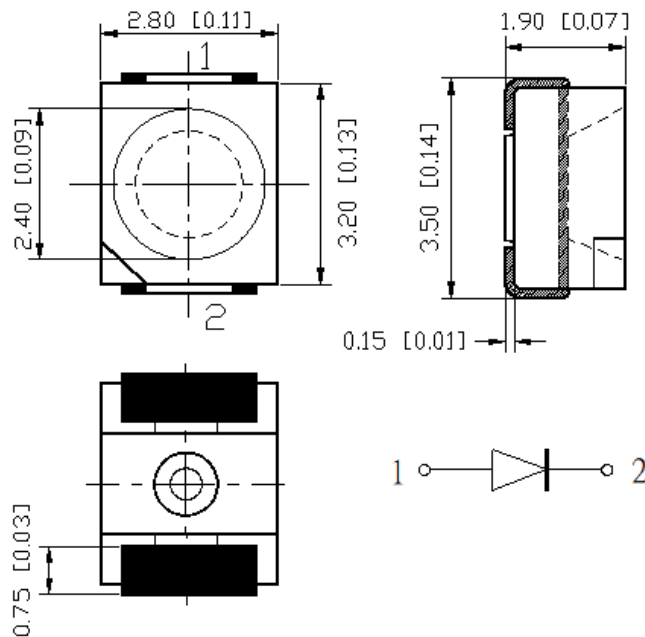

Units: mm / tolerance = +/-0.2mm

### Electrical / Optical Characteristic (Ta=25 °C)

Product	Color	I <sub>F</sub> (mA)	V <sub>F</sub> (V)		CIE Coordinates Typ.	I <sub>v</sub> (mcd)		
			Typ.	Max.		Min.	Typ.	Max.
QBLP670-IW	White	20	3.0	3.4	X=0.28, Y=0.26	1000	1900	3200

### Absolute Maximum Rating

Material	P <sub>d</sub> (mW)	I <sub>F</sub> (mA)	I <sub>FP</sub> (mA)*	V <sub>R</sub> (V)	T <sub>OP</sub> (°C)	T <sub>ST</sub> (°C)	T <sub>SO L</sub> (°C)**
InGaN	102	30	125	5	-40 to +80	-40 to +85	260

\*Duty 1/8 @ 1KHz

\*\*IR Reflow for no more than 10 sec @ 260 °C

### Forward Voltage V<sub>F</sub> @ I<sub>F</sub>=20mA

Bin	Min.	Max.	Unit
A	2.8	3.0	V
B	3.0	3.2	
C	3.2	3.4	

### Luminous Intensity I<sub>v</sub> @ I<sub>F</sub>=20mA

Bin	Min.	Max.	Unit
T	1000	1250	mcd
U	1250	1600	
V	1600	2000	
W	2000	2500	
X	2500	3200	

**Correlated Color Temperature Chart**

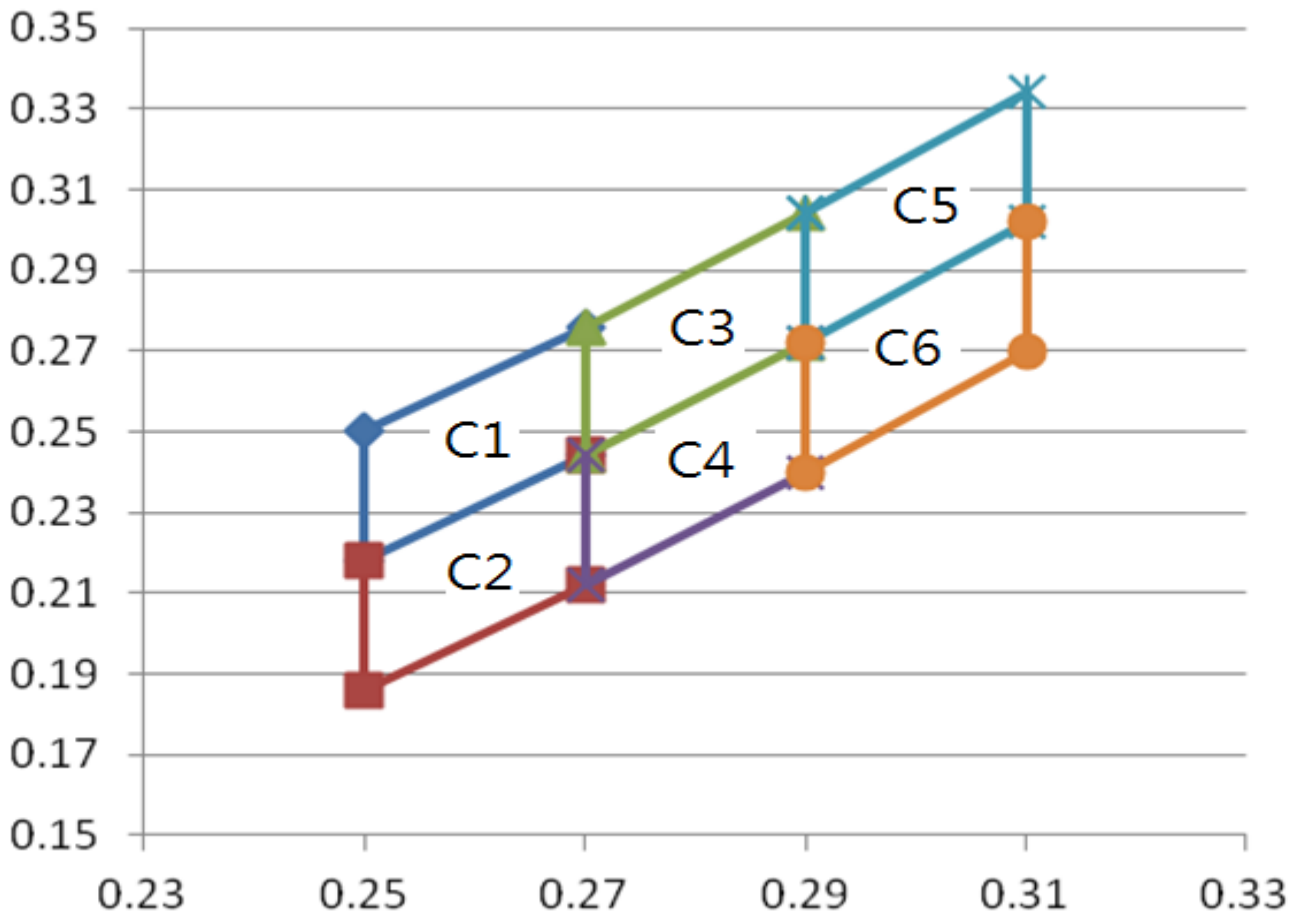

Rank	Chromaticity coordinates				
		X	Y	X	Y
C1	X	0.25	0.25	0.27	0.27
	Y	0.25	0.218	0.244	0.276
C2	X	0.25	0.25	0.27	0.27
	Y	0.218	0.186	0.212	0.244
C3	X	0.27	0.27	0.29	0.29
	Y	0.276	0.244	0.272	0.304
C4	X	0.27	0.27	0.29	0.29
	Y	0.244	0.212	0.24	0.272
C5	X	0.29	0.29	0.31	0.31
	Y	0.304	0.272	0.302	0.334
C6	X	0.29	0.29	0.31	0.31
	Y	0.272	0.24	0.27	0.302

**Characteristic Curves**

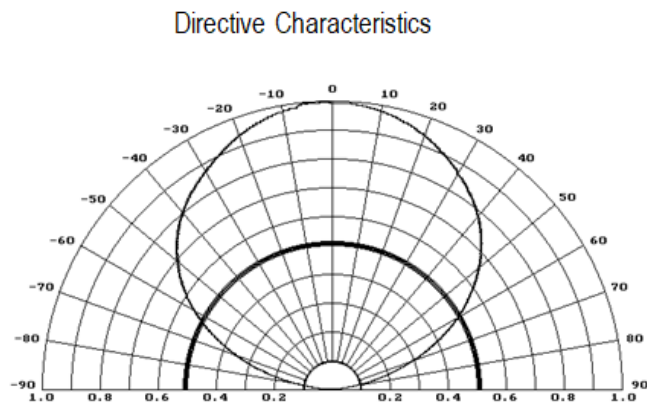
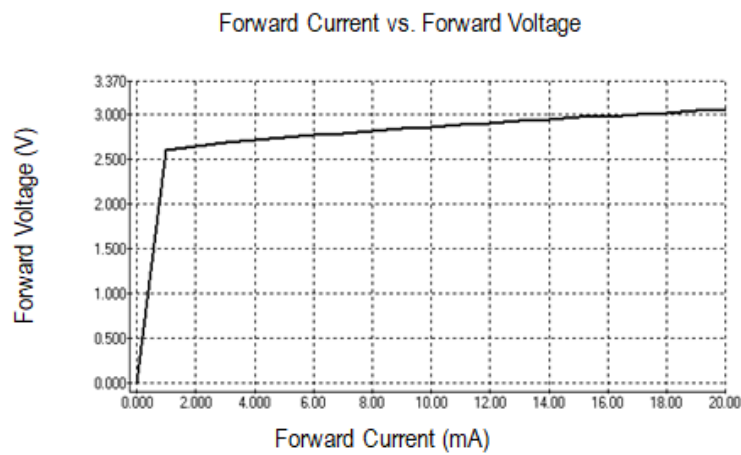
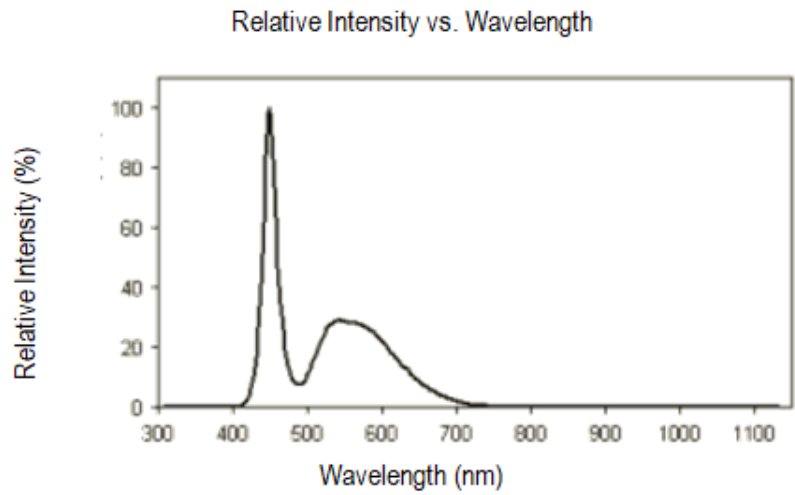

**Solder Profile & Footprint**

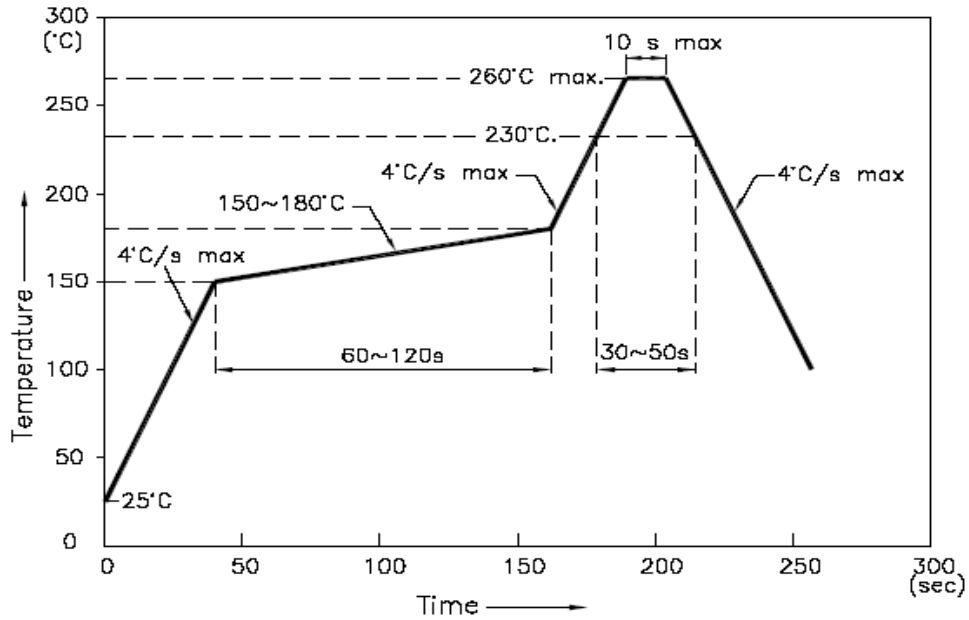

**Recommended Pad Layout**

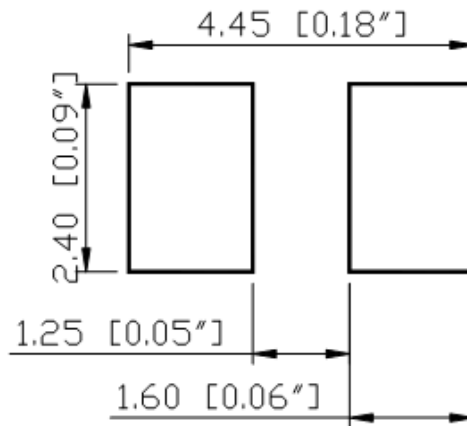

Units: mm

## Packing

Reel Dimension:

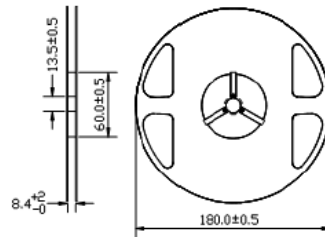

Unit: mm

Tape Dimension:

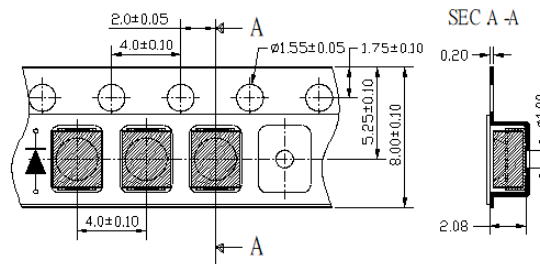

Unit: mm

Arrangement of Tape:

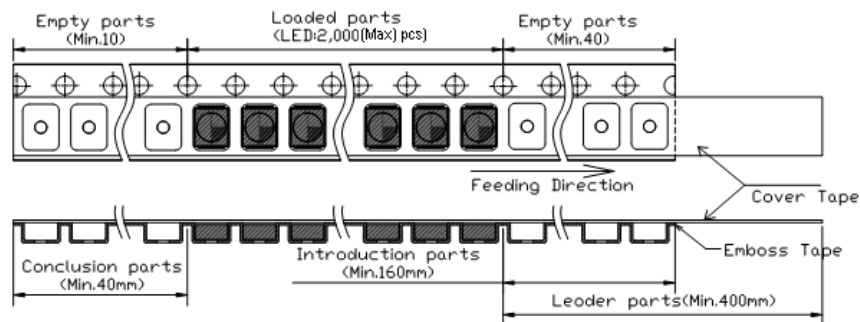

Packaging Specifications:

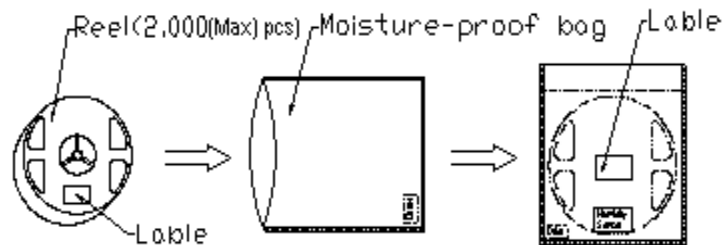



**Labeling**

Part No: \_\_\_\_\_

Customer P/N: \_\_\_\_\_

Item: \_\_\_\_\_

Q'ty: \_\_\_\_\_

Vf: \_\_\_\_\_

Iv: \_\_\_\_\_

WI: \_\_\_\_\_

Date: \_\_\_\_\_

**Made in China****Ordering Information**

Part #	Orderable Part #	Spec Range	Quantity per reel
QBLP670-IW	QBLP670-IW	Iv=1900mcd typ. @ 20mA / CIE Coordinate: (X=0.28, Y=0.26) typ.	2,000 units

**Revision History**

Description:	Revision #	Revision Date
New Release of QBLP670-IW	V1.0	12/16/2021

**Disclaimer**

QT-BRIGHTTEK reserves the right to make changes without further notice to any products herein to improve reliability, function or design. QT-BRIGHTTEK does not assume any liability arising out of the application or use of any product or circuit described herein; neither does it convey any license under its patent rights, nor the rights of others.

**Life Support Policy**

QT-BRIGHTTEK's products are not authorized for use as critical components in life support devices or systems without the express written approval of QT-BRIGHTTEK. As used herein:

1. Life support devices or systems are devices or systems which, (a) are intended for surgical implant into the body, or (b) support or sustain life, and (c) whose failure to perform when properly used in accordance with instructions for use provided in the labeling, can be reasonably expected to result in a significant injury of the user.
2. A critical component in any component of a life support device or system whose failure to perform can be reasonably expected to cause the failure of the life support device or system, or to affect its safety or effectiveness.