

DATA SHEET

TRIMMABLE CHIP RESISTORS

TR series

0/-10%, 0/-20%, 0/-30%

sizes 0402/0603/0805/1206

RoHS compliant



SCOPE

This specification describes TR0402 to TR1206 trimmable chip resistors with lead-free terminations made by thick film process.

APPLICATIONS

- Hand-held measuring equipment
- Mobile phones
- Camcorders
- Portable radios, CD and cassette
- Tuners
- Photo sensors

FEATURES

- RoHS compliant
 - Products with lead free terminations meet RoHS requirements
 - Pb-glass contained in electrodes, resistor element and glass are exempted by RoHS
- Reducing environmentally hazardous wastes
- High component and equipment reliability
- Saving of PCB space
- None forbidden-materials used in products/production

ORDERING INFORMATION - GLOBAL PART NUMBER & I2NC

Both part numbers are identified by the series, size, tolerance, packing type, temperature coefficient, taping reel and resistance value.

YAGEO BRAND ordering code

GLOBAL PART NUMBER (PREFERRED)

TR XXXX X X X XX XXXX
 (1) (2) (3) (4) (5) (6)

(1) SIZE

0402
0603
0805
1206

(2) TOLERANCE

K = 0/-10%
M = 0/-20%
N = 0/-30%

(3) PACKAGING TYPE

R = Paper taping reel

(4) TEMPERATURE COEFFICIENT OF RESISTANCE

- = Base on spec

(5) TAPING REEL

07 = 7 inch dia. Reel

(6) RESISTANCE VALUE

There are 2~4 digits indicated the resistor value. Letter R/K/M is decimal point, no need to mention the last zero after R/K/M, e.g. 1K2, not 1K20.

Detailed resistance rules show in table of "Resistance rule of global part number".

(7) OPTIONAL CODE

L = optional symbol (Note)

Resistance rule of global part number

Resistance code rule	Example
XRXX (1 to 9.76 Ω)	1R = 1 Ω 1R5 = 1.5 Ω 9R76 = 9.76 Ω
XXRX (10 to 97.6 Ω)	10R = 10 Ω 97R6 = 97.6 Ω
XXXR (100 to 976 Ω)	100R = 100 Ω
XKXX (1 to 9.76 KΩ)	1K = 1,000 Ω 9K76 = 9760 Ω
XMXX (1 to 9.76 MΩ)	1M = 1,000,000 Ω 9M76 = 9,760,000 Ω

ORDERING EXAMPLE

The ordering code of a TR0603 chip resistor, value 330 Ω with 0/-30% tolerance, supplied in 7-inch tape reel is: TR0603NR-07330R(L).

NOTE

1. All our RSMD products meet RoHS compliant. "LFP" of the internal 2D reel label mentions "Lead Free Process"
2. On customized label, "LFP" or specific symbol printed and the optional "L" at the end of GLOBAL PART NUMBER / I2NC can be added (both are on customer request)

PHYCOMP BRAND ordering codes

Both GLOBAL PART NUMBER (preferred) and I2NC (traditional) codes are acceptable to order Phycomp brand products.

GLOBAL PART NUMBER (PREFERRED)

For detailed information of GLOBAL PART NUMBER and ordering example, please refer to page 2.

I2NC CODE

SIZE	TYPE	2350 XXX XXXXX L				PAPER/PE TAPE ON REEL (units) ⁽²⁾			Resistance decade ⁽³⁾	Last digit
		(1)	(2)	(3)	(4)	10,000	5,000/10,000	5,000		
0402	RC32TR	2350	0/-10%	1 to 10 MΩ	503	22xxx	-	0.01 to 0.0976 Ω	0	
			0/-20%	1 to 10 MΩ	503	21xxx	-	0.1 to 0.976 Ω	7	
			0/-30%	1 to 10 MΩ	503	20xxx	-	1 to 9.76 Ω	8	
0603	RC22TR	2350	0/-10%	1 to 10 MΩ	-	502	12xxx	10 to 97.6 Ω	9	
			0/-20%	1 to 10 MΩ	-	502	11xxx	100 to 976 Ω	1	
			0/-30%	1 to 10 MΩ	-	502	10xxx	1 to 9.76 KΩ	2	
0805	RC12TR	2350	0/-10%	1 to 10 MΩ	-	501	12xxx	10 to 97.6 KΩ	3	
			0/-20%	1 to 10 MΩ	-	501	11xxx	100 to 976 KΩ	4	
			0/-30%	1 to 10 MΩ	-	501	10xxx	1 to 9.76 MΩ	5	
1206	RC02TR	2350	0/-10%	1 to 10 MΩ	-	500	12xxx	10 to 97.6 MΩ	6	
			0/-20%	1 to 10 MΩ	-	500	11xxx			
			0/-30%	1 to 10 MΩ	-	500	10xxx			

Example:	0.02 Ω	=	0200 or 200
	0.3 Ω	=	3007 or 307
	1 Ω	=	1008 or 108
	33 KΩ	=	3303 or 333
	10 MΩ	=	1006 or 106

- (1) The resistors have a 12-digit ordering code starting with 2350.
- (2) The subsequent 4 or 5 digits indicate the resistor tolerance and packaging.
- (3) The remaining 4 or 3 digits represent the resistance value with the last digit indicating the multiplier as shown in the table of "Last digit of I2NC".
- (4) "L" is optional symbol ^(Note).

ORDERING EXAMPLE

The ordering code of a RC22TR resistor with terminations, value 330 Ω with 0/-30% tolerance, supplied in tape of 5,000 units per reel is: 235050210331(L) or TR0603NR-07330R(L).

NOTE

- 1. All our RSMD products are RoHS compliant. "LFP" of the internal 2D reel label mentions "Lead Free Process"
- 2. On customized label, "LFP" or specific symbol printed and the optional "L" at the end of GLOBAL PART NUMBER / I2NC can be added (both are on customer request)

MARKING

TR0402/0603/0805/1206



No marking

For further marking information, please see special data sheet “Chip resistors marking”.

CONSTRUCTION

The resistors are constructed on a high-grade ceramic body (aluminium oxide). Internal metal electrodes are added at each end and a connection is made between them using a resistive metal glaze; the approximate resistor values are dependent on the composition of the glaze.

The resistive layer is covered with a translucent protective coat. Finally, two end electrodes are added, the composition of which has been designed to provide ease of soldering. See fig. 2.

OUTLINES

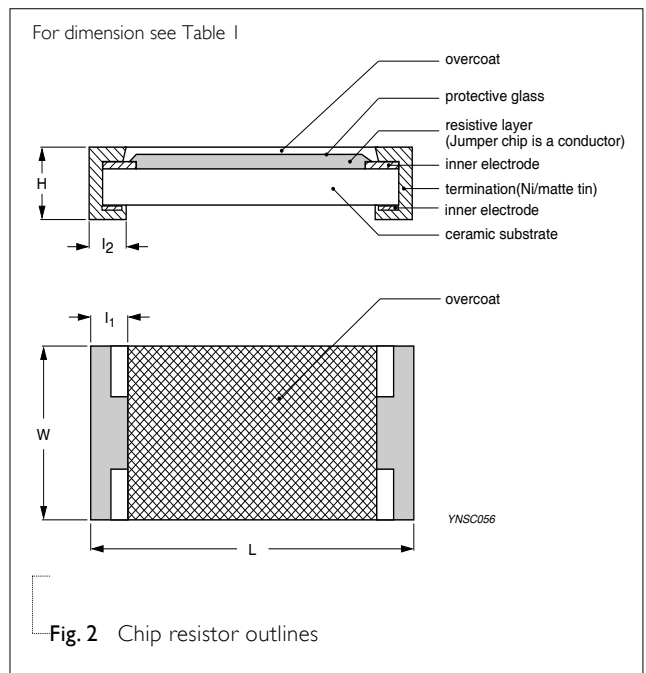

Fig. 2 Chip resistor outlines

DIMENSIONS

Table I For outlines see fig. 2

TYPE	L (mm)	W (mm)	H (mm)	l ₁ (mm)	l ₂ (mm)
TR0402	1.00 ±0.10	0.50 ±0.05	0.35 ±0.05	0.20 ±0.10	0.25 ±0.10
TR0603	1.60 ±0.10	0.80 ±0.10	0.45 ±0.10	0.25 ±0.15	0.25 ±0.15
TR0805	2.00 ±0.10	1.25 ±0.10	0.50 ±0.10	0.35 ±0.20	0.35 ±0.20
TR1206	3.10 ±0.10	1.60 ±0.10	0.55 ±0.10	0.45 ±0.20	0.40 ±0.20

ELECTRICAL CHARACTERISTICS

Table 2

TYPE	RESISTANCE RANGE	CHARACTERISTICS					Temperature Coefficient of Resistance
		Rated Power	Operating Temperature Range	Max. Working Voltage	Max. Overload Voltage	Dielectric Withstanding Voltage	
TR0402		1/16 W	-55 °C to +125 °C	50 V	100 V	100 V	1 Ω ≤ R ≤ 10 Ω: ±200 ppm/°C 10 Ω < R ≤ 1 MΩ: ±100 ppm/°C 1 MΩ < R ≤ 10 MΩ: ±200 ppm/°C
TR0603	0/-10%, 0/-20%, 0/-30%: 1 Ω to 10 MΩ	1/16 W		50 V	100 V	100 V	
TR0805	(E-24)	1/8 W	-55 °C to +155 °C	150 V	300 V	500 V	
TR1206		1/4 W		200 V	500 V	500 V	

FOOTPRINT AND SOLDERING PROFILES

For recommended footprint and soldering profiles, please see the special data sheet “Chip resistors mounting”.

PACKING STYLE AND PACKAGING QUANTITY

Table 3 Packing style and packaging quantity

PACKING STYLE	REEL DIMENSION	TR0402	TR0603	TR0805	TR1206
Paper taping reel (R)	7" (178 mm)	10,000	5,000	5,000	5,000

NOTE

I. For Paper tape and reel specification/dimensions, please see the special data sheet “Chip resistors packing”.

FUNCTIONAL DESCRIPTION

OPERATING TEMPERATURE RANGE

Each type range:

TR0402/0603: -55°C to +125°C;

TR0805/1206: -55°C to +155°C.

POWER RATING

Each type rated power at 70°C:

TR0402=1/16 W; TR0603=1/16 W;

TR0805=1/8 W; TR1206=1/4 W.

RATED VOLTAGE

The DC or AC (rms) continuous working voltage corresponding to the rated power is determined by the following formula:

$$V = \sqrt{P \times R}$$

or max. working voltage whichever is less

Where

V = Continuous rated DC or AC (rms) working voltage (V)

P = Rated power (W)

R = Resistance value (Ω)

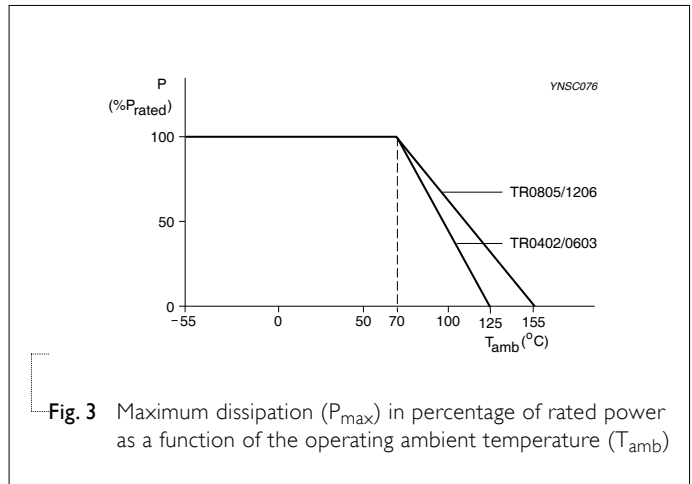

Fig. 3 Maximum dissipation (P_{max}) in percentage of rated power as a function of the operating ambient temperature (T_{amb})

TESTS AND REQUIREMENTS
Table 4 Test condition, procedure and requirements

TEST	TEST METHOD	PROCEDURE	REQUIREMENTS
Life/ Operational Life/ Endurance	MIL-STD-202G-method 108A	1,000 hours at 70±5 °C applied RCWV	±(2%+0.05 Ω)
	IEC 60115-1 4.25.1	1.5 hours on, 0.5 hour off, still air required	
	JIS C 5202-7.10		
High Temperature Exposure/ Endurance at upper category temperature	MIL-STD-202G-method 108A	1,000 hours at maximum operating temperature	±(1%+0.05 Ω)
	IEC 60115-1 4.25.3	depending on specification, unpowered	
	JIS C 5202-7.11	No direct impingement of forced air to the parts Tolerances: 155±3 °C	
Moisture Resistance	MIL-STD-202G-method 106F	Each temperature / humidity cycle is defined at 8 hours (method 106F), 3 cycles / 24 hours for 10d with 25 °C / 65 °C 95% R.H, without steps 7a & 7b, unpowered Parts mounted on test-boards, without condensation on parts Measurement at 24±2 hours after test conclusion	±(2%+0.05 Ω)
	IEC 60115-1 4.24.2		
Thermal Shock	MIL-STD-202G-method 107G	AR0402/0603: -55/+155 °C	±(0.5%+0.05 Ω) for 10 KΩ to 10 MΩ ±(1%+0.05 Ω) for others
		AR0805/1206: -55/+125 °C	
		Note: Number of cycles required is 300. Devices unmounted	
		Maximum transfer time is 20 seconds. Dwell time is 15 minutes. Air – Air	
Short time overload	MIL-R-55342D-para 4.7.5	2.5 times RCWV or maximum overload voltage whichever is less for 5 sec at room temperature	±(2%+0.05 Ω) No visible damage
	IEC60115-1 4.13		
Board Flex/ Bending	IEC60115-1 4.33	Device mounted on PCB test board as described, only 1 board bending required	±(1%+0.05 Ω) No visible damage
		3 mm bending	
		Bending time: 60±5 seconds Ohmic value checked during bending	

TEST	TEST METHOD	PROCEDURE	REQUIREMENTS
Solderability - Wetting	IPC/JEDECJ-STD-002B test B	Electrical Test not required	Well tinned ($\geq 95\%$ covered)
	IEC 60068-2-58	Magnification 50X SMD conditions: 1 st step: method B, aging 4 hours at 155 °C dry heat 2 nd step: leadfree solder bath at 245 \pm 3 °C Dipping time: 3 \pm 0.5 seconds	No visible damage
- Leaching	IPC/JEDECJ-STD-002B test D IEC 60068-2-58	Leadfree solder, 260 °C, 30 seconds immersion time	No visible damage
- Resistance to Soldering Heat	MIL-STD-202G-method 210F	Condition B, no pre-heat of samples	$\pm(1\%+0.05 \Omega)$
	IEC 60068-2-58	Leadfree solder, 270 °C, 10 seconds immersion time Procedure 2 for SMD: devices fluxed and cleaned with isopropanol	No visible damage

REVISION HISTORY

REVISION	DATE	CHANGE NOTIFICATION	DESCRIPTION
Version 1	Jan 14, 2009	-	<ul style="list-style-type: none"> - Change to dual brand datasheet that describes TR0402 to TR1206 with RoHS compliant - Define global part number
Version 0	Oct 18, 2005	-	<ul style="list-style-type: none"> - New datasheet for trimmable chip resistors sizes of 0402/0603/0805/1206, 0/-10%, 0/-20, and 0/-30% tolerance with lead-free terminations - Replace the 0603/0805/1206 parts of pdf files: RC02TR_12TR_9.pdf, RC22_TR_3.pdf, and combine into a document. - Test method and procedure updated - PE tape added (paper tape will be replaced by PE tape)

“Yageo reserves all the rights for revising the content of this datasheet without further notification, as long as the products itself are unchanged. Any product change will be announced by PCN.”

LEGAL DISCLAIMER

YAGEO, its distributors and agents (collectively, "YAGEO"), hereby disclaims any and all liabilities for any errors, inaccuracies or incompleteness contained in any product related information, including but not limited to product specifications, datasheets, pictures and/or graphics. YAGEO may make changes, modifications and/or improvements to product related information at any time and without notice.

YAGEO makes no representation, warranty, and/or guarantee about the fitness of its products for any particular purpose or the continuing production of any of its products. To the maximum extent permitted by law, YAGEO disclaims (i) any and all liability arising out of the application or use of any YAGEO product, (ii) any and all liability, including without limitation special, consequential or incidental damages, and (iii) any and all implied warranties, including warranties of fitness for a particular purpose, non-infringement and merchantability.

YAGEO products are designed for general purpose applications under normal operation and usage conditions. Please contact YAGEO for the applications listed below which require especially high reliability for the prevention of defects which might directly cause damage to the third party's life, body or property: Aerospace equipment (artificial satellite, rocket, etc.), Atomic energy-related equipment, Aviation equipment, Disaster prevention equipment, crime prevention equipment, Electric heating apparatus, burning equipment, Highly public information network equipment, data-processing equipment, Medical devices, Military equipment, Power generation control equipment, Safety equipment, Traffic signal equipment, Transportation equipment and Undersea equipment, or for any other application or use in which the failure of YAGEO products could result in personal injury or death, or serious property damage. Particularly **YAGEO Corporation and its affiliates do not recommend the use of commercial or automotive grade products for high reliability applications or manned space flight.**

Information provided here is intended to indicate product specifications only. YAGEO reserves all the rights for revising this content without further notification, as long as products are unchanged. Any product change will be announced by PCN.