



American Opto Plus LED Corp.

L955MBC

3.5 x 2.8 x 1.9 mm Blue PLCC2 LED

PACKAGE SPECIFICATIONS

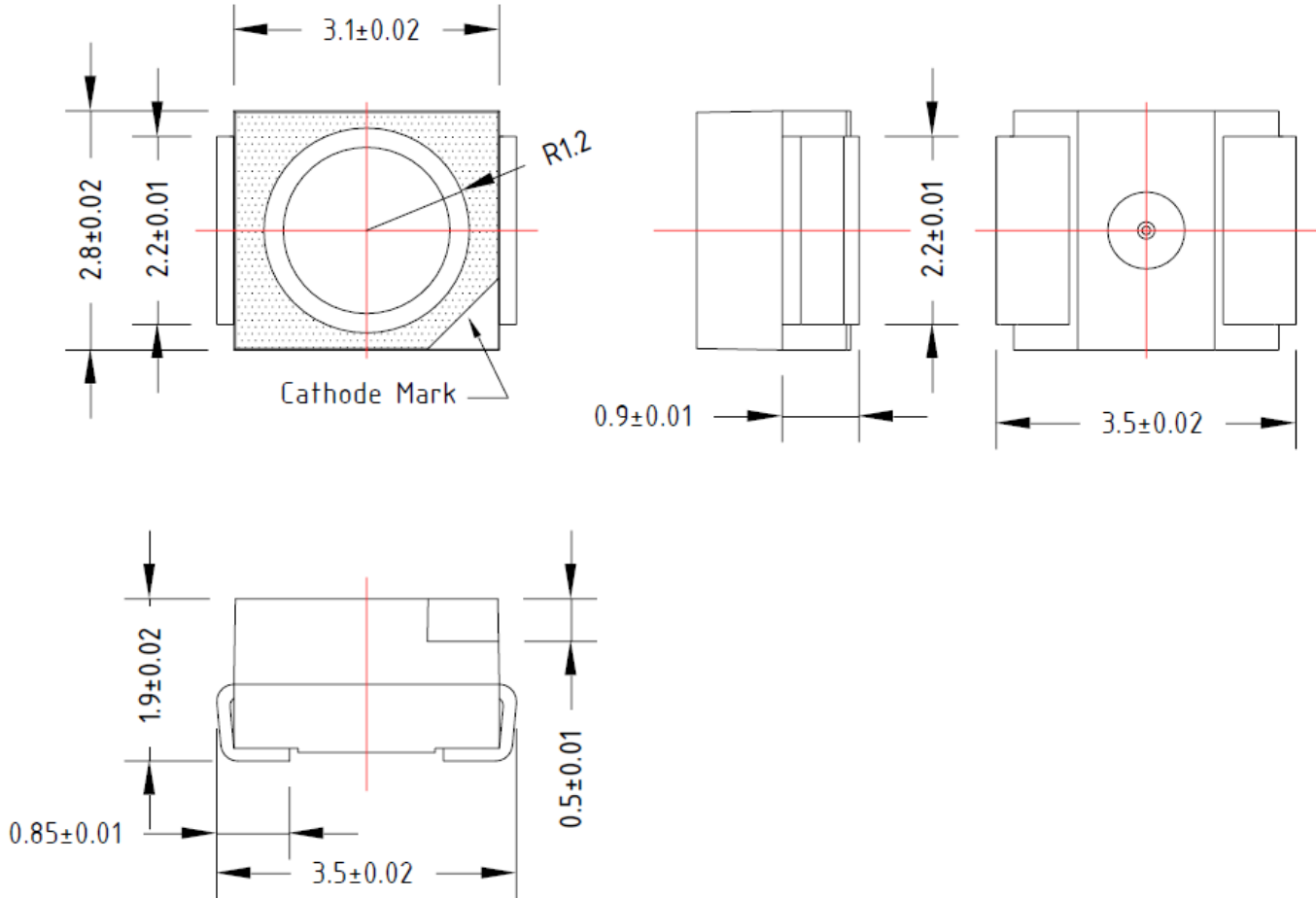

Item	Materials
Package	Heat-Resistant Polymer
Encapsulating Resin	Silicone
Electrodes	Ag Plating Copper Alloy

NOTES:

1. All dimensions in mm
2. Electrical connection between all cathodes is recommended
3. Specifications are subject to change without notice

Chip Material	Chip Emitted	Lens Color	Viewing Angle
InGaN	Blue	Water Clear	120



American Opto Plus LED Corp.

L955MBC

3.5 x 2.8 x 1.9 mm Blue PLCC2 LED

ABSOLUTE MAXIMUM RATINGS

(Ta=25°C)

Parameter	Symbol	Ratings	Unit
DC Forward Current	I _F	30	mA
Peak Pulsed Forward Current	I _{FP}	100	mA
Reverse Voltage	V _R	5	V
Power Dissipation	P _d	72	mW
Operating temperature range	Topr	-30~+85	°C
Storage temperature range	Tstg	-40~+100	°C
Solder Dipping Temperature	Tsld	265°C for 10 sec	

OPTICAL-ELECTRICAL CHARACTERISTICS

(Ta=25°C)

Parameter	Symbol	Condition	Min	Typ	Max	Unit
Forward Voltage	V _F	I _f =20mA	--	3.2	3.5	V
Luminous Flux	Φ _V		--	1200	--	mlm
Luminous Intensity	I _V		180	300	--	mcd
Dominant Wavelength	λ _d		460	470	480	nm
Peak Wavelength	λ _p		--	465	--	nm
Spectral Half Width	Δλ 1/2		--	20	--	nm
Reverse Current	I _R	V _r = 5V	--	--	50	μA

- Measurement Uncertainty of Luminous Intensity: ±10%
- Please refer to CIE 1931 chromaticity diagram



American Opto Plus LED Corp.

L955MBC

3.5 x 2.8 x 1.9 mm Blue PLCC2 LED

Luminous Intensity Bin Table

IF=20mA

Rank Name	Min (mcd)	Max (mcd)
H	180	240
J	240	310
K	310	400
L	400	520

Tolerance for each bin limit is $\pm 15\%$

Color Bin Table

IF=20mA

Rank Name	Min (nm)	Max (nm)
1	460	465
2	465	470
3	470	475
4	475	480

Tolerance for each bin limit is $\pm 1\text{nm}$

Notes:

1. One delivery will include several color ranks and I_v ranks of products.
The quantity-ratio of the different rank is decided by AOP.
2. Bin Name typed on the Label: IV RANK + Color Rank.
For Example, **BIN K2 Means IV: 310-400mcd, Color: 465nm~470nm**
3. Static Electricity or Surge Voltage damages the LEDs.
It is recommended to use a wrist band or Anti-Electrostatic glove when handling the LEDs.
4. AOP has the right to update the information without notice.
Please double confirm the Spec details before placing an order



American Opto Plus LED Corp.

L955MBC

3.5 x 2.8 x 1.9 mm Blue PLCC2 LED

TYPICAL ELECTRICAL-OPTICAL CHARACTERISTIC CURVES

Forward Current vs. Forward Voltage

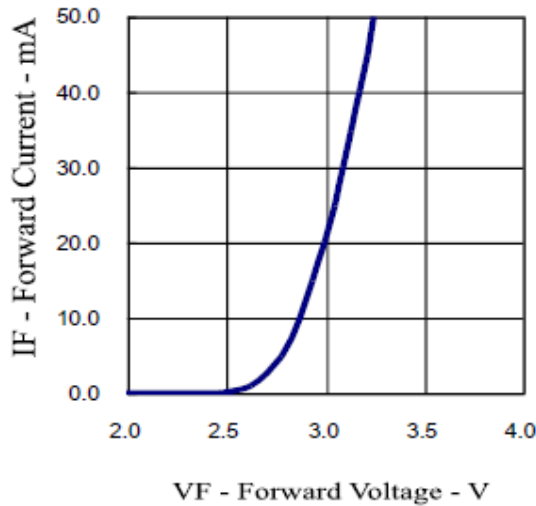

Relative Intensity vs. Forward Current

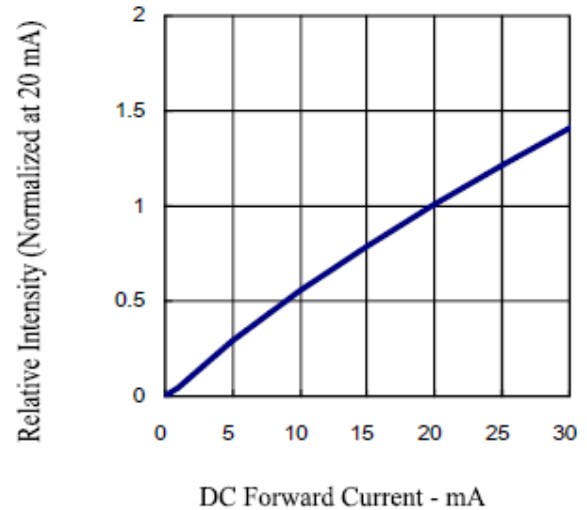

Forward Current vs. Ambient Temperature

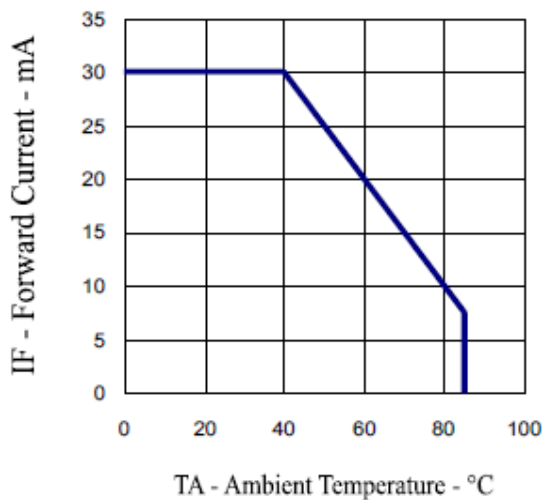

Relative Intensity vs. Wavelength

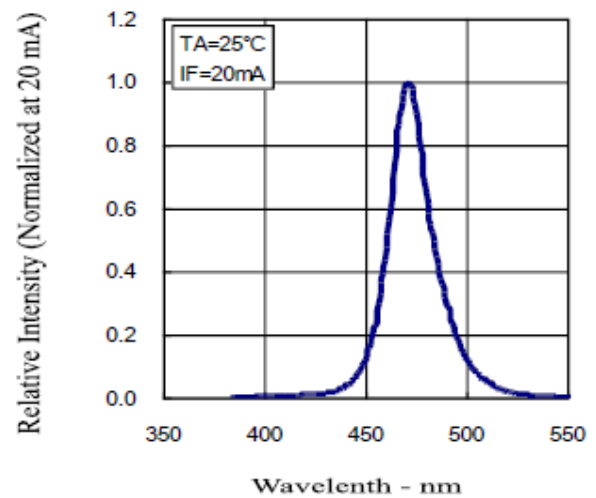



American Opto Plus LED Corp.

L955MBC

3.5 x 2.8 x 1.9 mm Blue PLCC2 LED

RADIATION PATTERN

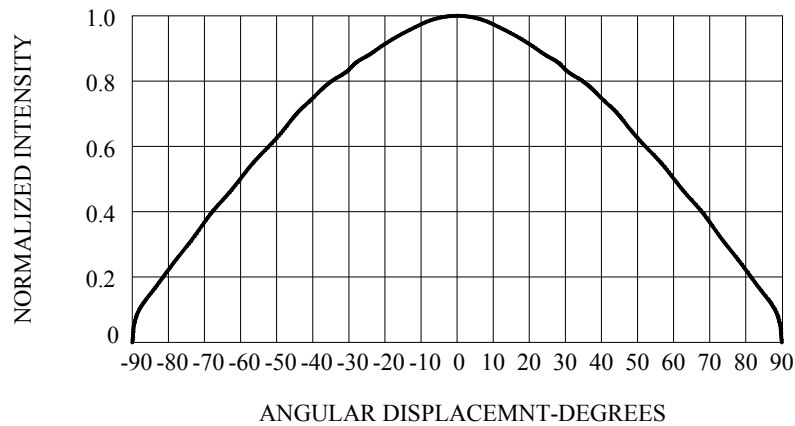

RECOMMENDED SOLDERING PATTERN

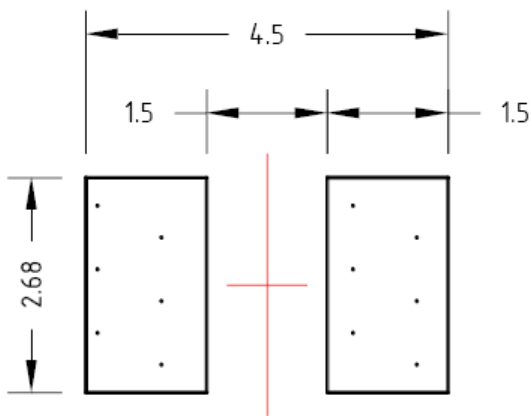

(Unit:mm)

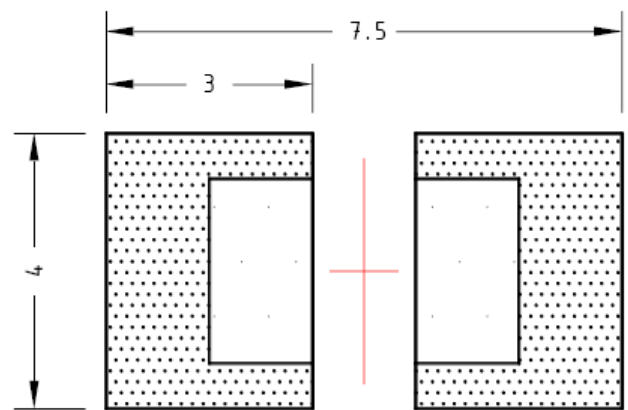

 Solder resist(Unit:mm)



American Opto Plus LED Corp.

L955MBC

3.5 x 2.8 x 1.9 mm Blue PLCC2 LED

SOLDERING CONDITIONS

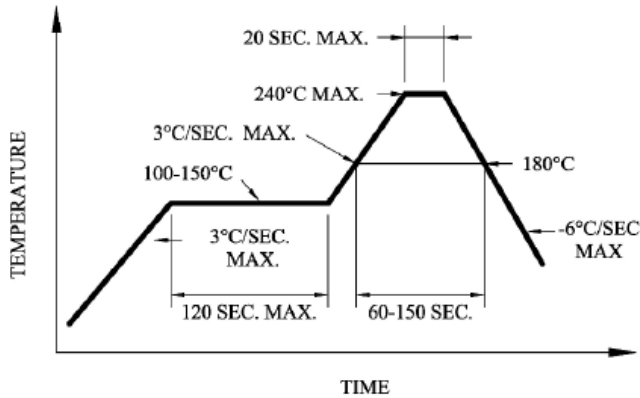

Recommended reflow soldering profile

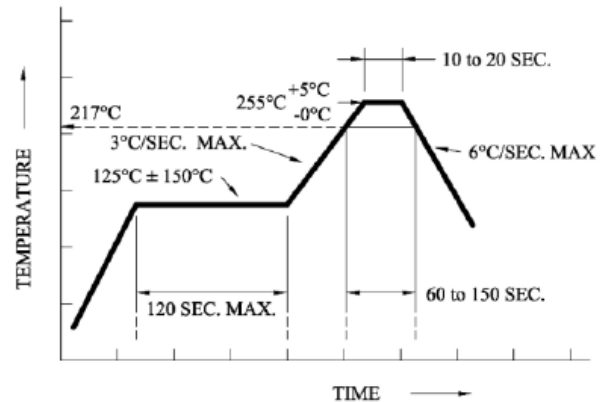

Recommended Pb-free reflow soldering profile.

- Repairing should not be done after the LEDs have been soldered. When repairing is unavoidable, a double-head soldering iron should be used. It should be confirmed beforehand whether the Characteristics of the LEDs will or will not be damaged by repairing.
- Reflow soldering should not be done more than two times.
- When soldering, do not put stress on the LEDs during heating.
- After soldering, do not warp the circuit board.

TAPE DIMENSION

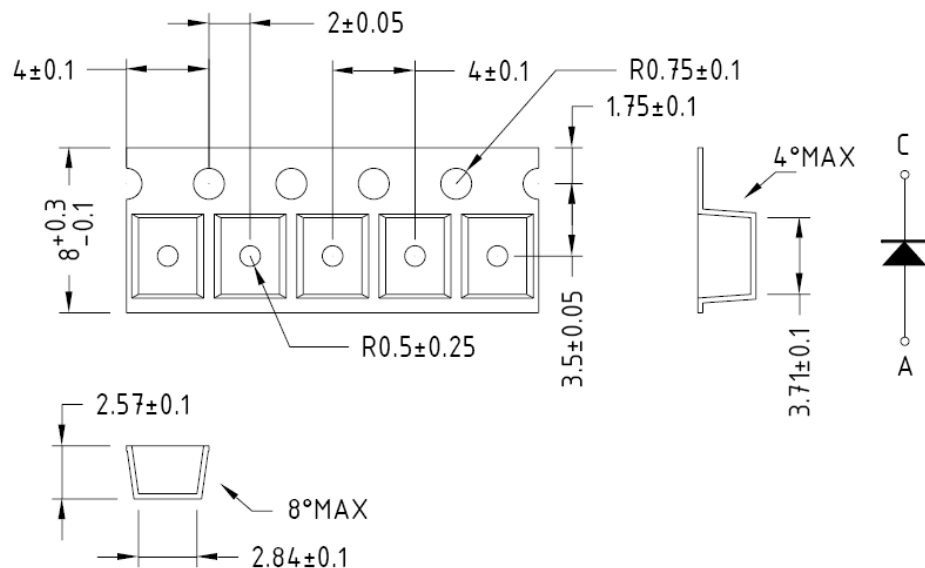



American Opto Plus LED Corp.

L955MBC

3.5 x 2.8 x 1.9 mm Blue PLCC2 LED

TAPE LEADER AND TRAILER DIMENSION

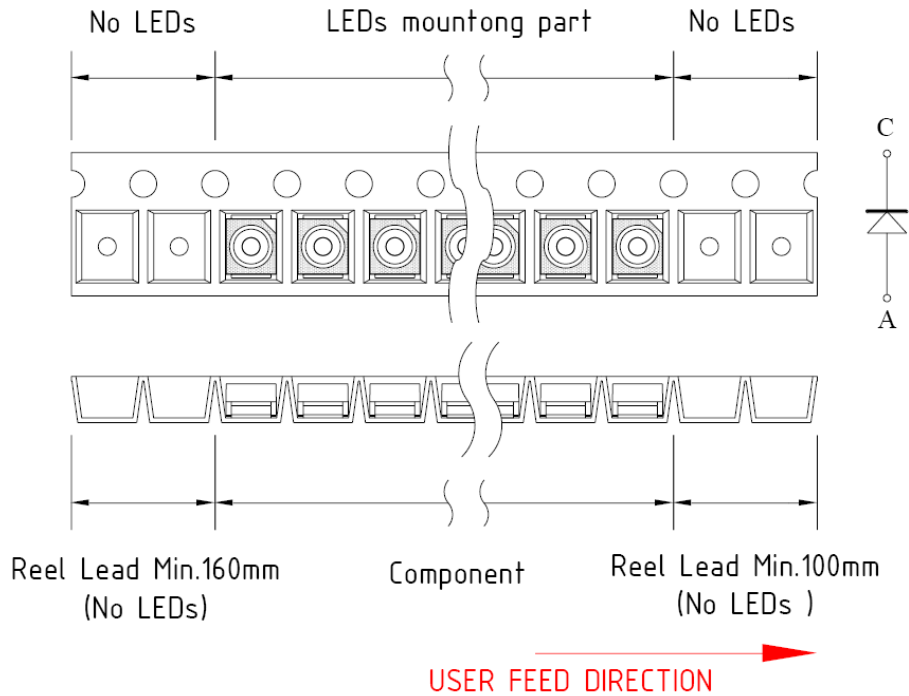

REEL DIMENSION

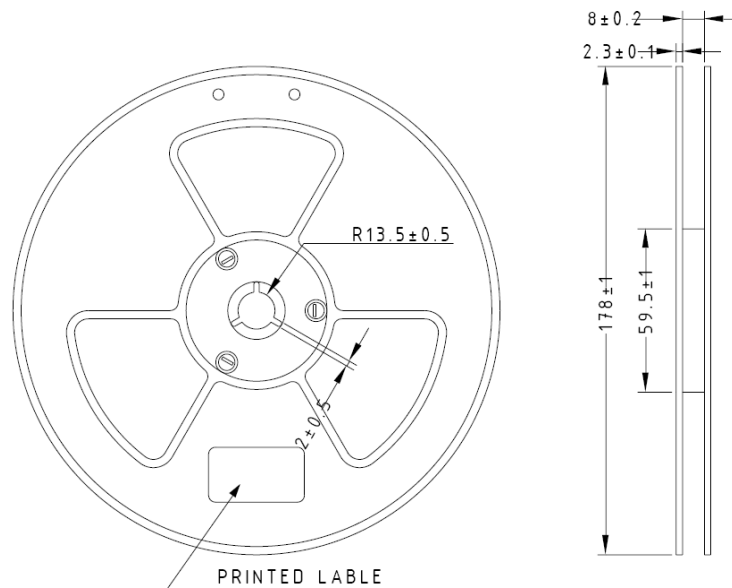

Note : Baking is required under the following conditions:
The pack has been opened for more than four weeks.
Baking recommended conditions:
 $60 \pm 5 \text{ }^\circ\text{C}$ for 20 hours.
Reel Size: 2000 pcs