

SUL6001 Low Noise High PSRR 1 Ch 500mA/ 1A Ultra Low Dropout LDO

FUNCTIONAL DESCRIPTION

The SUL6001 series is a CMOS-based positive low-dropout linear regulator (LDO) featuring 500mA/ 1.0A that provides high PSRR, high output voltage accuracy, low-noise and low supply current.

It consists of a voltage reference, an error amplifier, a resistor-ladder for output voltage setting. It also has under-voltage lockout (UVLO), over current/short circuit protection circuit and over temperature shutdown circuit.

The SUL6001 typically has 85mV dropout voltage (DFN1216-8, I_{out}=1A, V_{out}=3.3V) and 140mV dropout voltage (DFN1216-8, I_{out}=1A, V_{out}=1.8V) and chip enable function (EN) for long battery life.

Excellent ripple rejection, load transient and line transient response make it ideal for the power sources of mobile communication devices or camera modules in low light condition. It can also turn on under full load condition, making it suitable for harsh system environment.

The SUL6001 series LDOs have option for output current limit between 1A or 500mA by alternating the LCON pin between “H” or “L” for DFN1216-8 package version.

The SUL6001 is available in SOT23-5, DFN2x2-6, DFN3x3-8, DFN1216-8 package, and standard products are Pb-free and Halogen-free.

MAIN FEATURES

- Supply Current (no load): 85μA (typ.)
- Supply Current (Standby): 0.1μA (typ.)
- Low Dropout Voltage: 85mV @1A, 50mV @500mA, when V_{out}=3.3V
- High-PSRR: 85dB @1kHz
- Ultra Low Output Noise: 10μV_{rms} (10-100KHz, 0.85V output voltage settings, typ.)
- Line Regulation: 0.01%/V
- Fixed Mode Voltage Range: 0.85V to 4.3V with 0.05V step.
- Adjustable Mode Voltage Range: 0.85V to 4.6V
- Built-in Short Current Protection Limit: 120mA (LCON='H', 1.0A, typ.)
- Built-in Peak Current Protection Limit: 1.7A (LCON='H', 1.0A, typ.)
- Over Temperature Protection and Auto Recover
- Built-in Soft-Start and Inrush Current Limit
- Fast Auto Discharge Function for Power Down

APPLICATIONS

- Portable Device , Tablets and Smartphone
- Cameras, VCRs and Car Dash Cameras
- Low Light & Low Noise Cam Application
- Communications and Infrastructure
- AR or VR Application
- DDR Application

TYPICAL APPLICATION CIRCUIT

Typical application circuit for fixed version

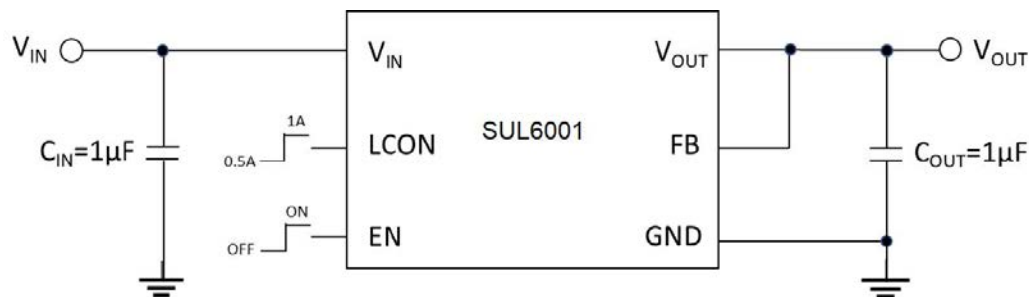

Note: Recommended Ceramic Capacitors for V_{in} and V_{out} : 1µF

Typical application circuit for Adjustable (ADJ) version

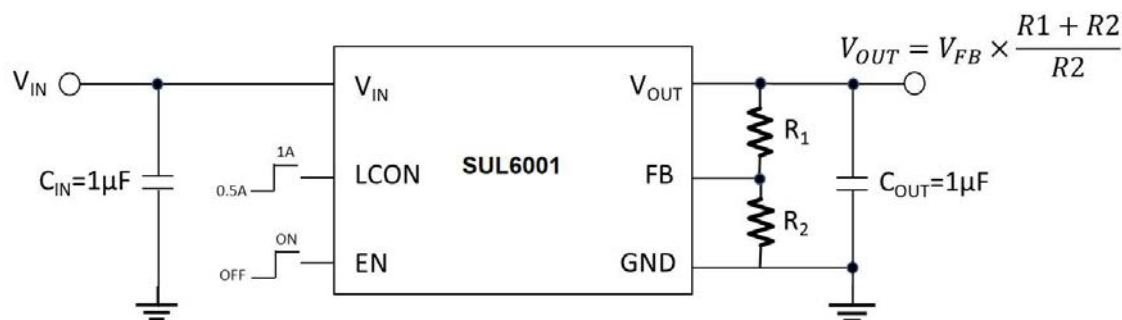

The adjustable-version device requires external feedback divider resistors to set the output voltage. V_{OUT} is set using the feedback divider resistors, R_1 and R_2 , according to the following equation:

$$V_{OUT} = V_{FB} \times (1 + R_1 / R_2)$$

For this device, $V_{FB} = 0.85$ V.

To ignore the FB pin current error term in the V_{OUT} equation, set the feedback divider current to 100x the FB pin current listed in the Electrical Characteristics table. This setting provides the maximum feedback divider series resistance, as shown in the following equation:

$$R_1 + R_2 \leq V_{OUT} / (I_{FB} \times 100)$$

For this device, $I_{FB} = 10$ nA.

PIN ASSIGNMENT & DESCRIPTION

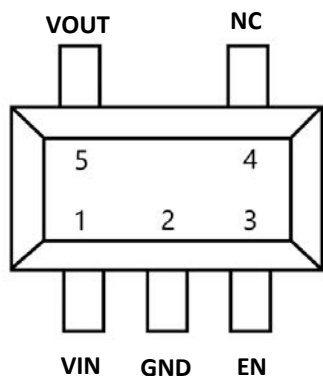

SOT23-5 (Fixed Mode)

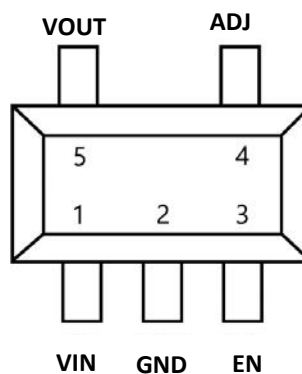

SOT23-5 (Adjustable Mode)

PIN No	Symbol	Pin Description
1	VIN	Input of supply voltage pin
2	GND	Ground pin
3	EN	Enable pin
4	NC/ADJ	No connection / Adjustable output pin
5	VOUT	LDO output voltage pin

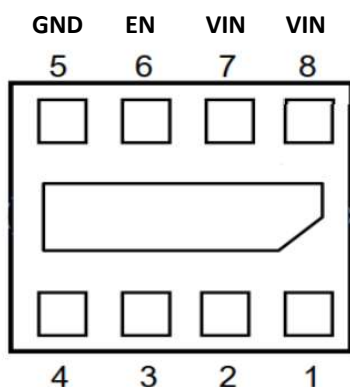

DFN1216-8 (Fixed Mode)

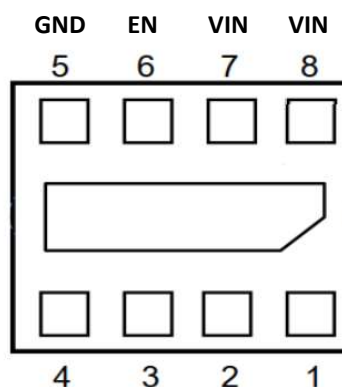

DFN1216-8 (Adjustable Mode)

PIN No	Symbol	Pin Description
1	VOUT	LDO output voltage pin
2	VOUT	LDO output voltage pin
3	LCON	Output current limit alternate pin
4	NC/ADJ	No connection / Adjustable output pin
5	GND	Ground pin
6	EN	Enable pin
7	VIN	Input of supply voltage
8	VIN	Input of supply voltage

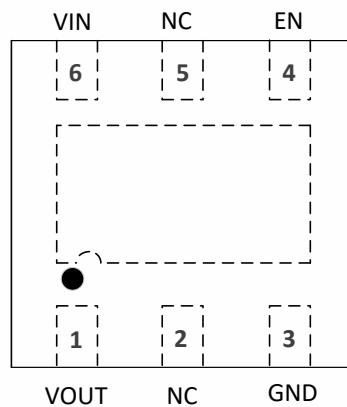

DFN2x2-6 (Fixed Mode)

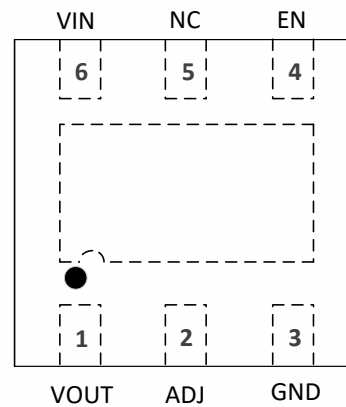

DFN2x2-6 (Adjustable Mode)

PIN No	Symbol	Pin Description
1	VOUT	LDO output voltage pin
2	NC/ADJ	No connection / Adjustable output pin
3	GND	Ground pin
4	EN	Enable pin
5	NC	No connection
6	VIN	Input of supply voltage

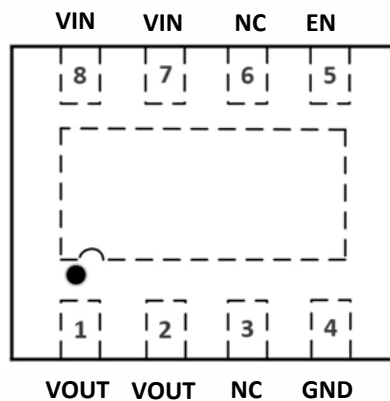

DFN3x3-8 (Fixed Mode)

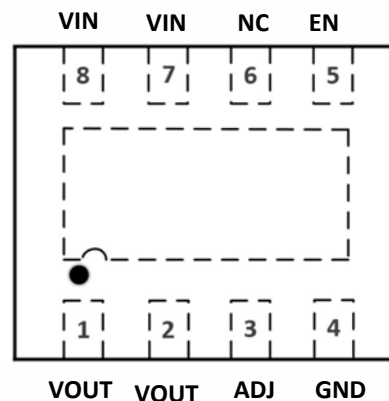

DFN3x3-8 (Adjustable Mode)

PIN No	Symbol	Pin Description
1	VOUT	LDO output voltage pin
2	VOUT	LDO output voltage pin
3	NC/ADJ	No connection / Adjustable output pin
4	GND	Ground pin
5	EN	Enable pin
6	NC	No connection
7	VIN	Input of supply voltage
8	VIN	Input of supply voltage

***Note: Connect exposed pad (heat sink on the back) to GND.**

ORDER INFORMATION

Part Number	Package	Tape/Reel	Output Type
SUL6001S5-XX	SOT23-5	3000	Fixed / ADJ
SUL6001D6-XX	DFN2x2-6	3000	Fixed / ADJ
SUL6001-DRB	DFN3x3-8	5000	ADJ
SUL6001D8-XX	DFN1216-8	3000	Fixed / ADJ

For example, 28 means product outputs 2.8V, ADJ/DRB means adjustable output.
SUL6001 devices are Pb-free and RoHS compliant.

ABSOLUTE MAXIMUM RATINGS

Symbol	Item	Rating	Unit
V_{IN}	Input Voltage	6.0	V
V_{CE}	Input Voltage (CE Pin)	-0.3 to 6.0	V
V_{LCON}	Input Voltage (LCON Pin)	-0.3 to 6.0	V
V_{OUT}	Output Voltage	-0.3 to 6.0	V
P_D	Power Dissipation (Standard Land Pattern)	SOT23-5	mW
		DFN2x2-6	
		DFN3X3-8	
		DFN1216-8	
T_{OP}	Junction Temperature Range	-40 to 125	°C
T_{STG}	Storage Temperature Range	-55 to 125	°C

ESD RATINGS

Symbol	Parameter	Value	Unit
ESD	Human Body Mode	± 4	kV
	Machine Mode	± 250	V
	Charge Device Mode	± 1000	V

THERMAL DATA

Symbol	Parameter	Package	Value	Unit
θ_{JA}	Thermal resistance junction-ambient	SOT23-5	260	°C/W
		DFN2x2-6		
		DFN3X3-8		
		DFN1216-8	80	

RECOMMENDED OPERATING CONDITIONS

Symbol	Item	Rating	Unit
V_{IN}	Input Voltage	1.32 to 5.5	V
V_{OUT}	Output Voltage	0.85 to 4.3	V
T_a	Operating Temperature Range	-40 to 85	°C
C_{IN}/C_{OUT}	Input/Output Capacitance	1/1	uF

ELECTRICAL CHARACTERISTICS

$V_{IN} = V_{OUT} + 1.0\text{ V}$, $I_{OUT} = 1\text{ mA}$, $C_{IN} = C_{OUT} = 1.0\text{ }\mu\text{F}$, typical values are at $T_J = 25\text{ }^\circ\text{C}$; unless otherwise noted.

Symbol	Parameter	Conditions	Min.	Typ.	Max.	Unit	
V_{IN}	Operating input voltage		1.32		5.50	V	
V_{OUT}	V_{OUT} accuracy	$V_{OUT} + 0.5\text{V} \leq V_{IN} \leq 5.5\text{V}$	$V_{OUT} \geq 1.75\text{V}$	-1.0	+1.0	%	
			$V_{OUT} < 1.75\text{V}$	-20	+20	mV	
V_{FB}	V_{FB} accuracy	$V_{IN} = 2.0\text{V}$, $I_{LOAD} = 1\text{mA}$	0.8415	0.85	0.8585	V	
ΔV_{OUT}	Static line regulation			0.01		%/V	
ΔV_{OUT}	Static load regulation	$I_{OUT} = 10\text{mA to } 500\text{mA}$		1	20	mV	
		$I_{OUT} = 10\text{mA to } 1000\text{mA}$			40		
V_{DROP}	Dropout voltage	$I_{OUT} = 1\text{A}$	$V_{OUT}=1.2\text{V}$		245	340	mV
			$V_{OUT}=1.8\text{V}$		140	235	
			$V_{OUT}=2.5\text{V}$		105	175	
			$V_{OUT}=3.3\text{V}$		85	150	
			$V_{OUT}=4.3\text{V}$		60	130	
		$I_{OUT} = 500\text{mA}$ For SOT-23-5	$V_{OUT}=1.2\text{V}$		150	210	
			$V_{OUT}=1.8\text{V}$		80	135	
			$V_{OUT}=2.5\text{V}$		60	100	
			$V_{OUT}=3.3\text{V}$		50	105	
			$V_{OUT}=4.3\text{V}$		40	85	
I_Q	Quiescent current	$I_{OUT} = 0\text{mA}$		85	140	μA	
$I_{standby}$	Standby current	V_{IN} input current in OFF MODE: $V_{EN} = \text{GND}$		0.1	3	μA	
I_{LIM}	Output current limit	$I_{OUT} = 500\text{mA}$	0.6	0.78		A	
		$I_{OUT} = 1\text{A}$		1.7			
I_{SC}	Short-circuit current	$V_{OUT} = 0\text{ V}$	$I_{OUT} = 500\text{mA}$		186	mA	
			$I_{OUT} = 1\text{A}$		150		
I_{FB}	Feedback pin current			0.01	0.1	μA	
e_N	Output noise voltage			10		μVrms	
PSRR	Power Supply Rejection Ratio			85		dB	
T_{TSD}	Thermal shutdown	Shutdown, temperature increasing		165		$^\circ\text{C}$	
		Reset, temperature decreasing		135			
CE	Enable input logic low	$V_{IN} = 1.32\text{ V to } 5.5\text{ V}$			0.4	V	
	Enable input logic high	$V_{IN} = 1.32\text{ V to } 5.5\text{ V}$	1				
$LCON$	LCON input logic low	$V_{IN} = 1.32\text{ V to } 5.5\text{ V}$			0.4	V	
	LCON input logic high	$V_{IN} = 1.32\text{ V to } 5.5\text{ V}$	1				

LOAD REGULATION (DYNAMIC)

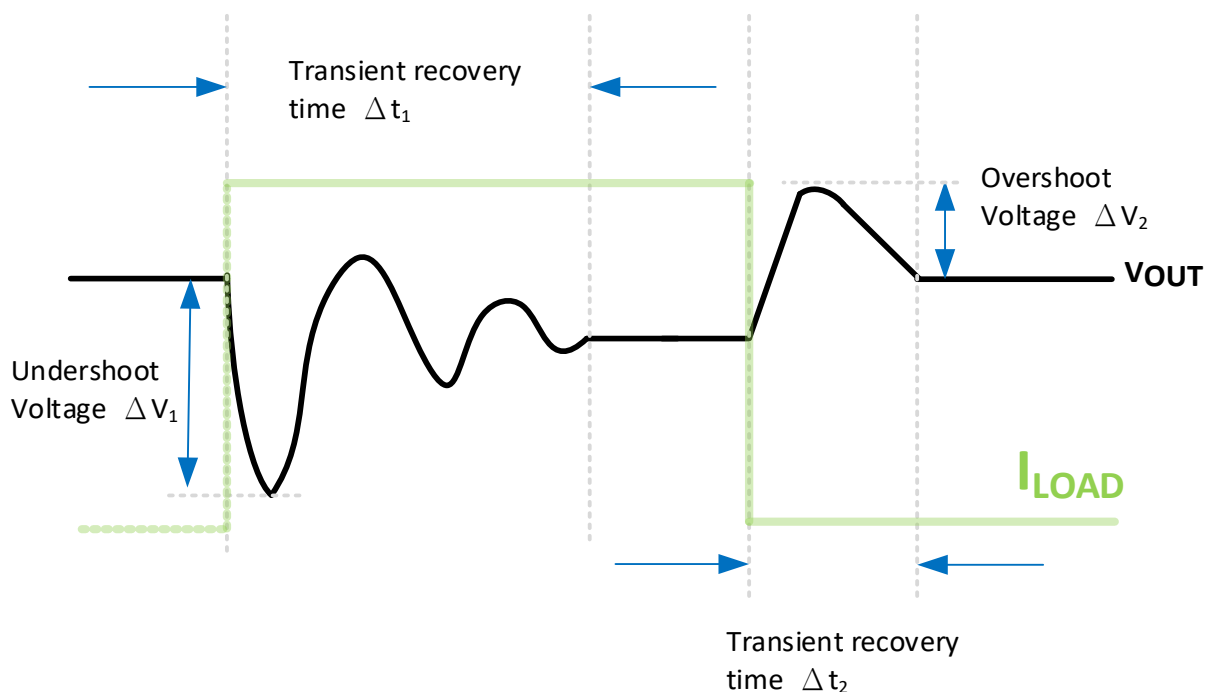

Symbol	Parameter	Condition	Min.	Typ.	Max.	Unit
ΔV ₁	Undershoot Voltage	I _{LOAD} =1mA~250mA		30		mV
		I _{LOAD} =1mA~500mA		40		
		I _{LOAD} =1mA~1A		62		
		I _{LOAD} =0mA~300mA		50		
		I _{LOAD} =0mA~1A		90		
ΔV ₂	Overshoot Voltage	I _{LOAD} =1mA~250mA		28		mV
		I _{LOAD} =1mA~500mA		40		
		I _{LOAD} =1mA~1A		60		
		I _{LOAD} =0mA~300mA		35		
		I _{LOAD} =0mA~1A		65		
Δt ₁	Transient recovery time	I _{LOAD} =1mA~250mA		10		μS
		I _{LOAD} =1mA~500mA		16		
		I _{LOAD} =1mA~1A		18		
		I _{LOAD} =0mA~300mA		60		
		I _{LOAD} =0mA~1A		80		
Δt ₂	Transient recovery time	I _{LOAD} =1mA~250mA		12		μS
		I _{LOAD} =1mA~500mA		12		
		I _{LOAD} =1mA~1A		16		
		I _{LOAD} =0mA~300mA		90		
		I _{LOAD} =0mA~1A		300		

*This table is SUL6001D8-33 measurement data. For detail load regulation information about other SUL6001 series LDOs, please contact SUNTEK.

TYPICAL CHARACTERISTICS

$V_{IN} = V_{SET}^{(1)} + 1.0\text{ V}$, $I_{OUT} = 1\text{ mA}$, $C_{IN} = C_{OUT} = 1.0\text{ }\mu\text{F}$, $LCON = "H"$, typical values are at $T_J = 25\text{ }^\circ\text{C}$; unless otherwise noted.

Output Voltage vs. Input Voltage ($C_{IN} = C_{OUT} = 1.0\text{ }\mu\text{F}$, $T_a = 25\text{ }^\circ\text{C}$)

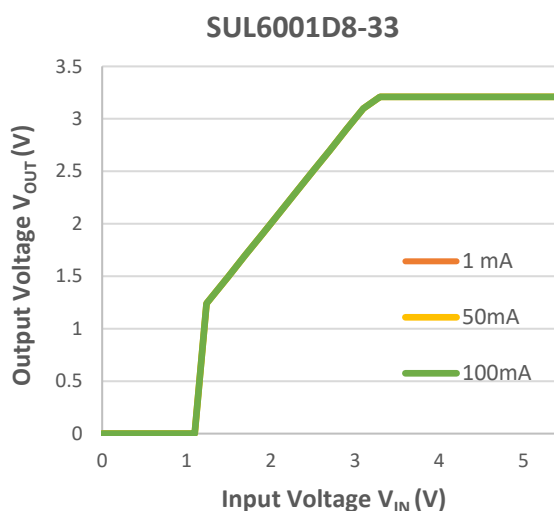
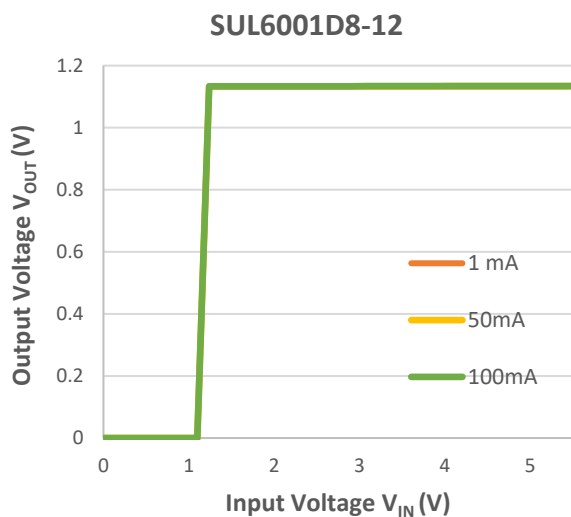

Supply Current vs. Input Voltage ($C_{IN} = C_{OUT} = 1.0\text{ }\mu\text{F}$, $T_a = 25\text{ }^\circ\text{C}$)

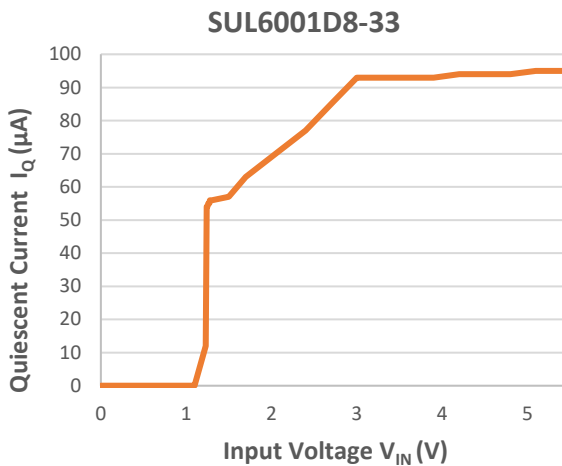
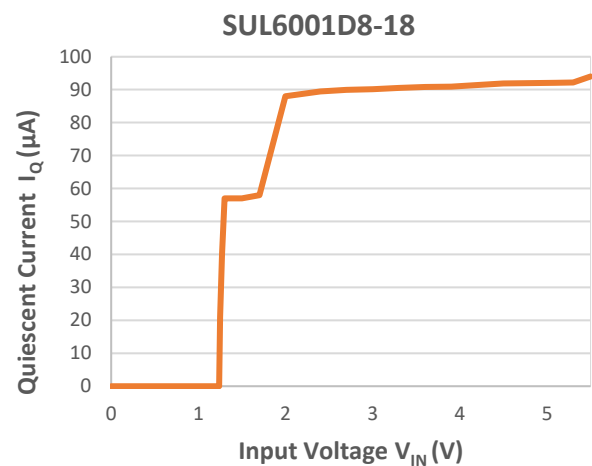
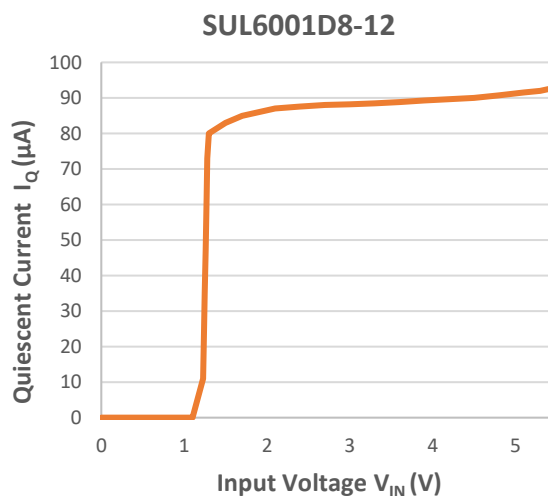
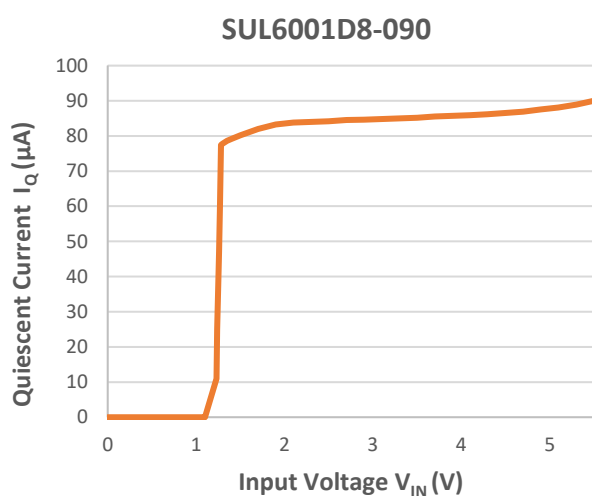

Supply Current vs. Temperature ($C_{IN} = C_{OUT} = 1.0\mu F$, $I_{OUT} = 0\text{ mA}$)

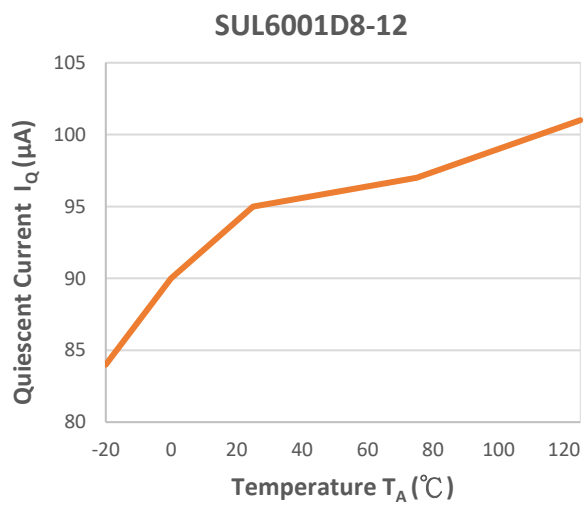

Over Current Protect Foldback Characteristic (LCON = V_{IN} , $C_{IN} = C_{OUT} = 1.0\mu F$, $T_a = 25^\circ C$)

SUL6001D8-090

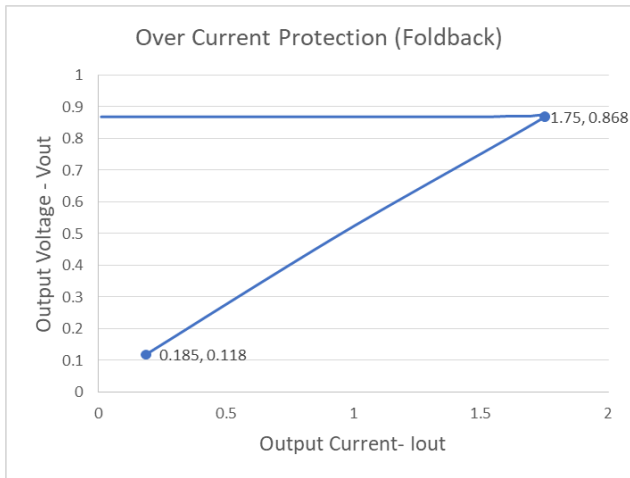

SUL6001D8-12

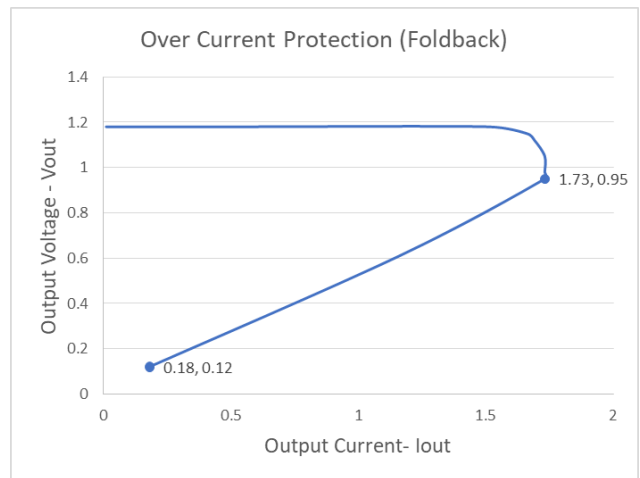

SUL6001D8-18

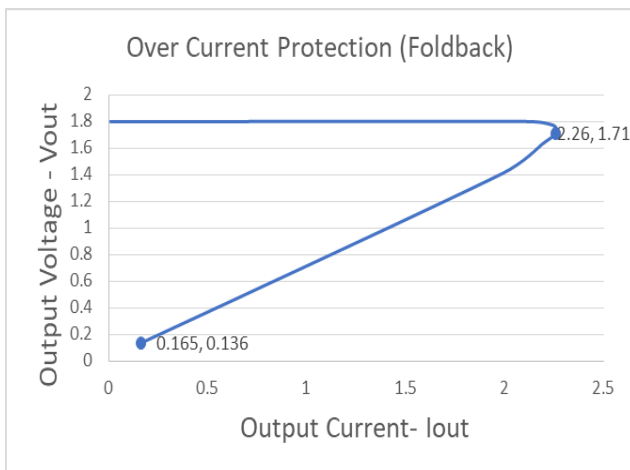

SUL6001D8-25

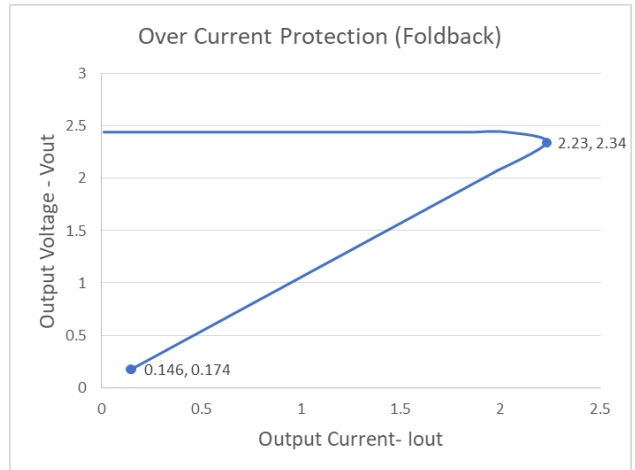

SUL6001D8-33

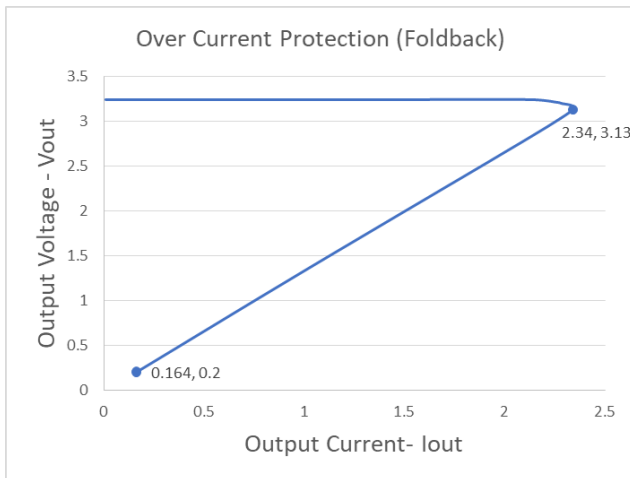

SUL6001D8-43

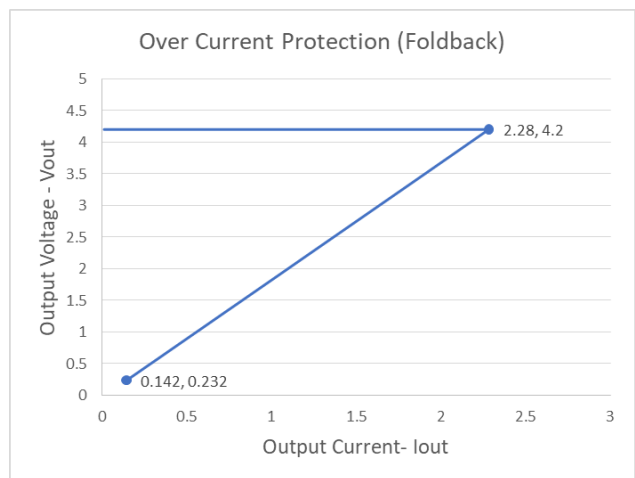

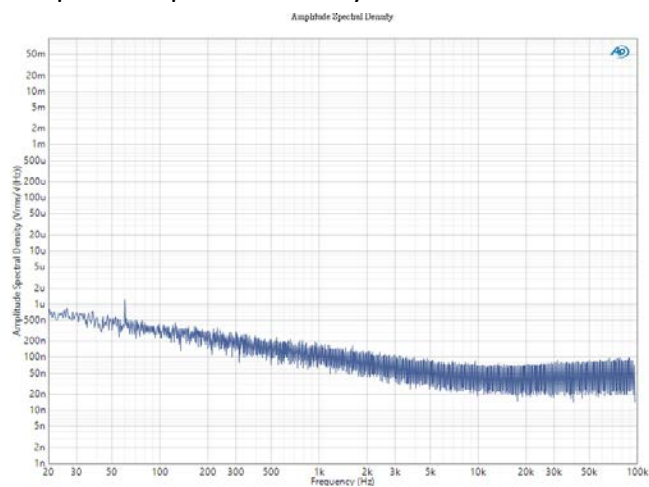
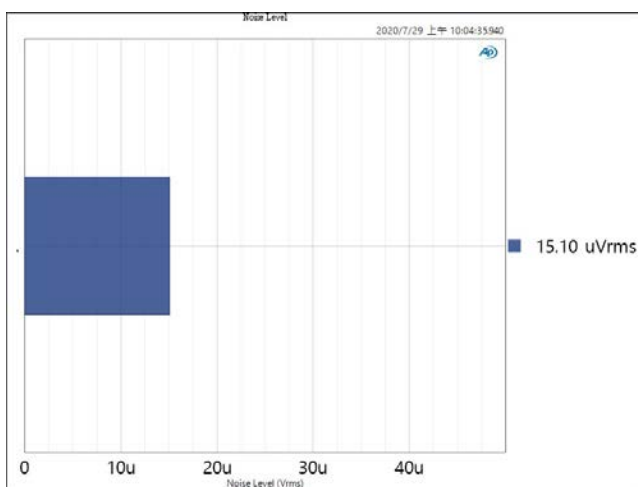
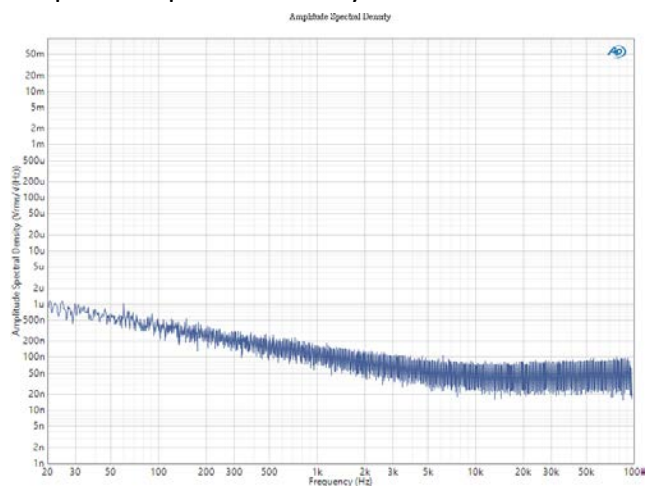
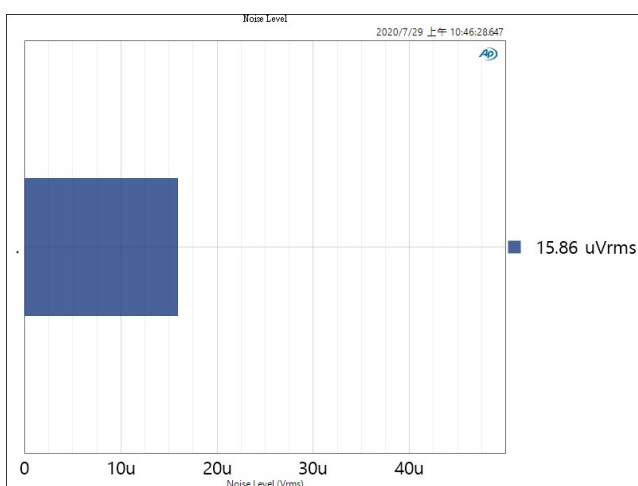
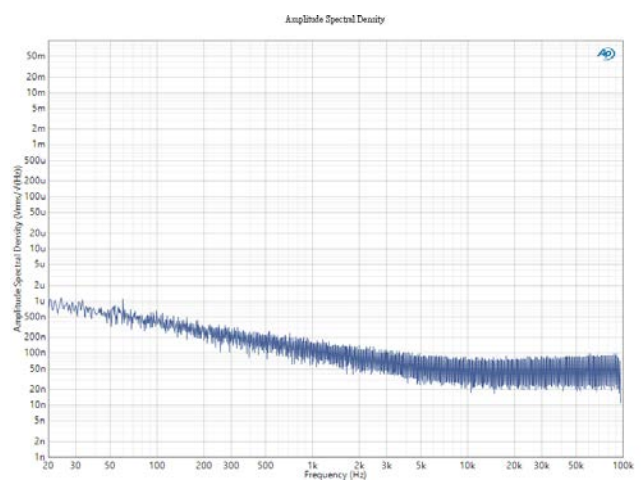
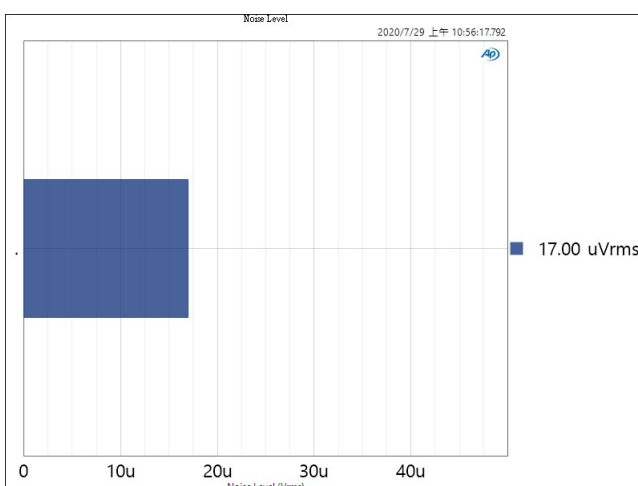
Output Noise Voltage (10 Hz to 100 kHz, $C_{IN} = C_{OUT} = 1.0 \mu F, T_a = 25^\circ C$)
SUL6001D8-090, $I_{OUT} = 100 \text{ mA}$
Amplitude Spectral Density

 V_{RMS} from 10 Hz to 100 kHz

SUL6001D8-12, $I_{OUT} = 100 \text{ mA}$
Amplitude Spectral Density

 V_{RMS} from 10 Hz to 100 kHz

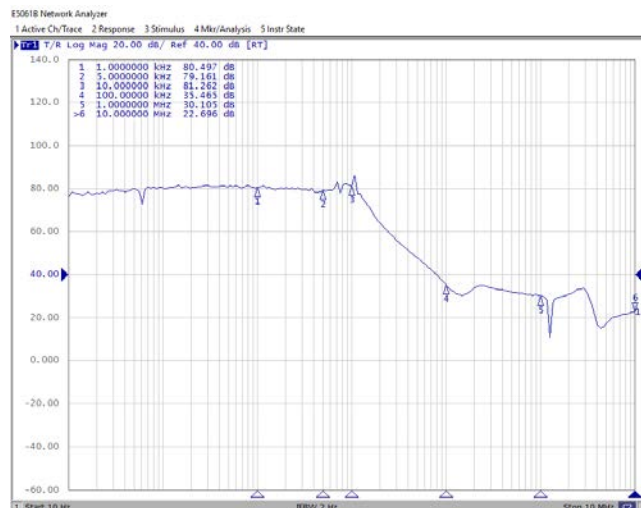
SUL6001D8-33, $I_{OUT} = 100 \text{ mA}$
Amplitude Spectral Density

 V_{RMS} from 10 Hz to 100 kHz

Power Supply Ripple Rejection vs. Frequency ($V_{IN}=V_{OUT}+1V$, $C_{IN} = C_{OUT} = 1.0\mu F$, Ripple = 0.2 Vp-p, $T_a = 25^\circ C$)

SUL6001D8-090

$I_{Load}=1mA$



$I_{Load}=10mA$

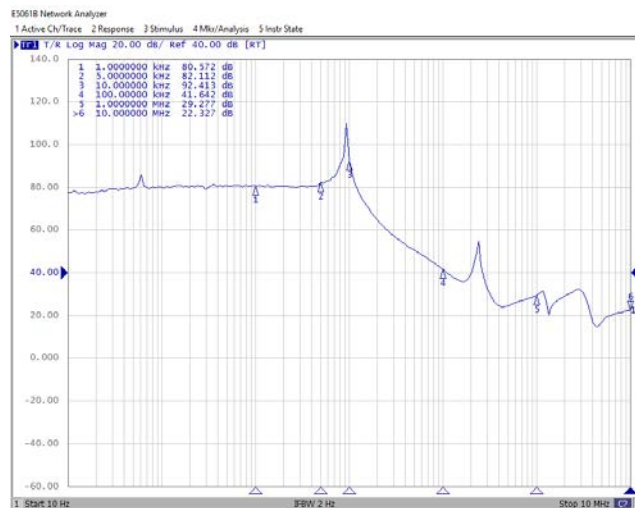

$I_{Load}=30mA$

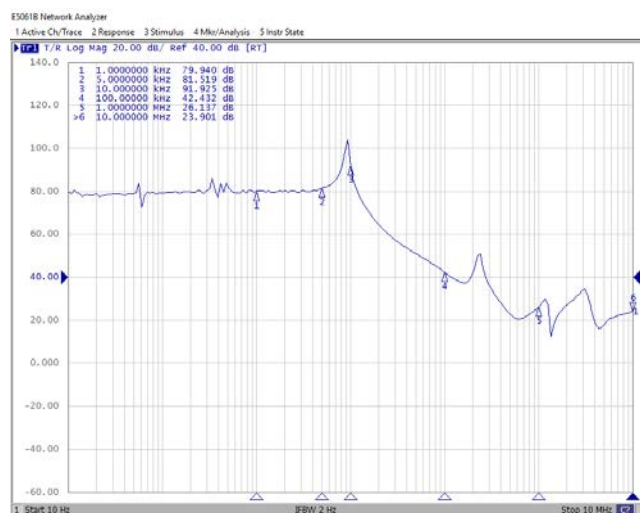

$I_{Load}=150mA$

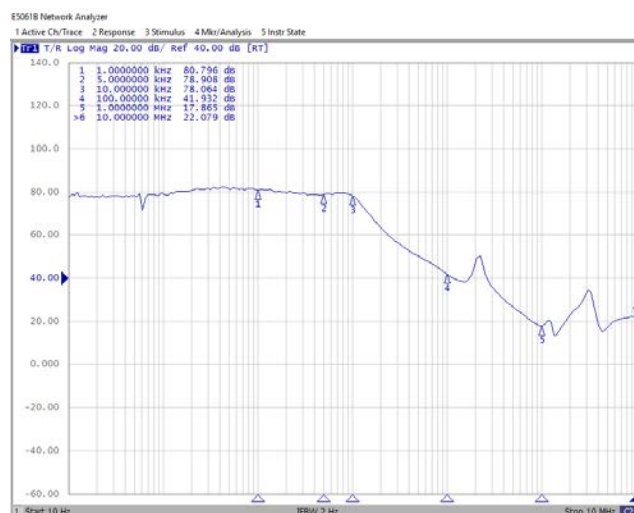

SUL6001D8-12

$I_{Load}=1mA$

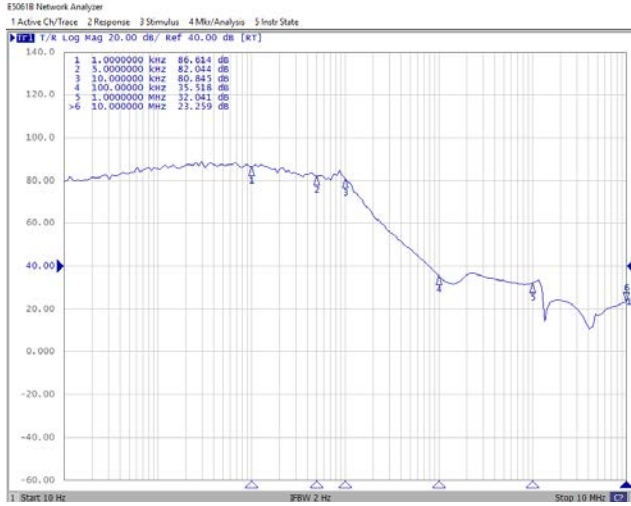

$I_{Load}=10mA$

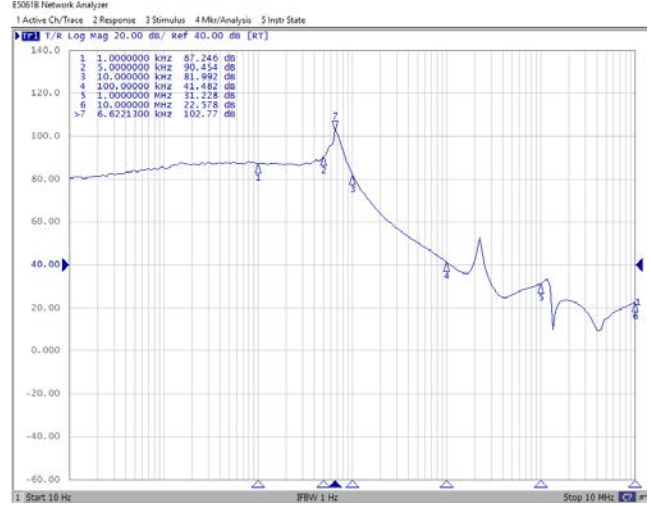

$I_{Load}=30mA$

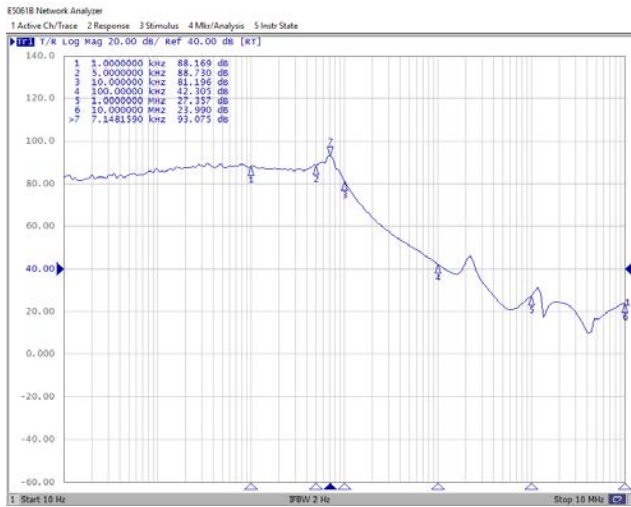

$I_{Load}=150mA$

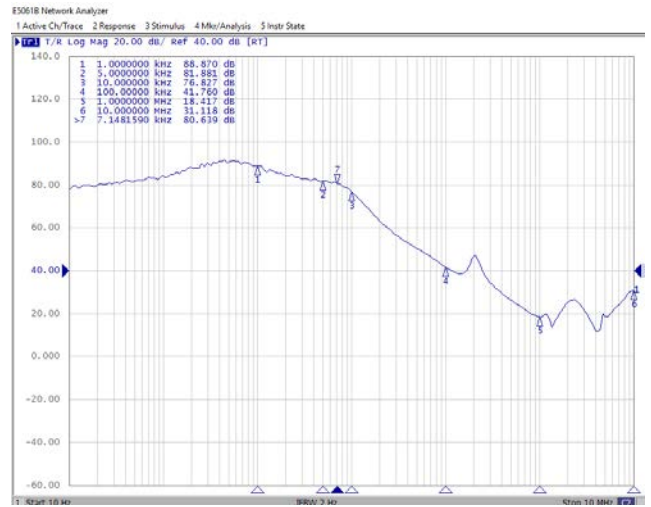

SUL6001D8-18

$I_{Load}=1mA$



$I_{Load}=10mA$

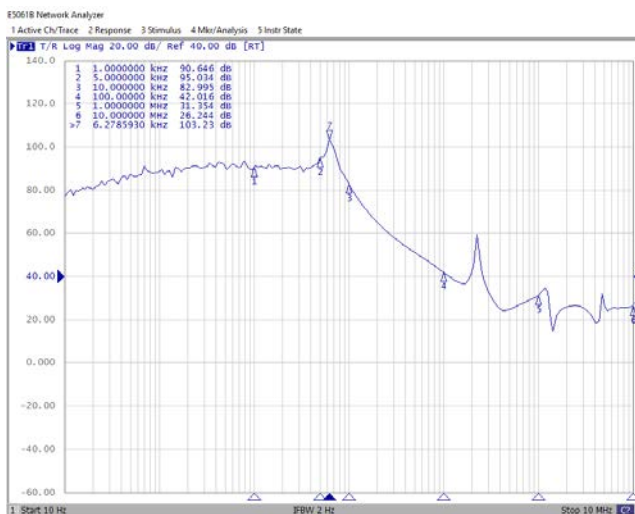

$I_{Load}=30mA$

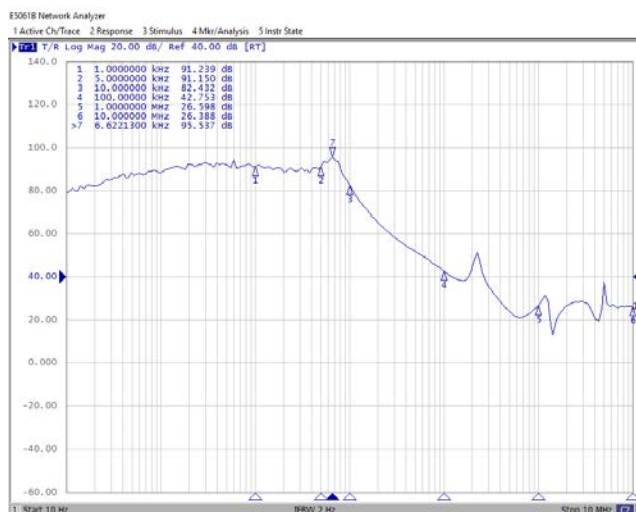

$I_{Load}=150mA$

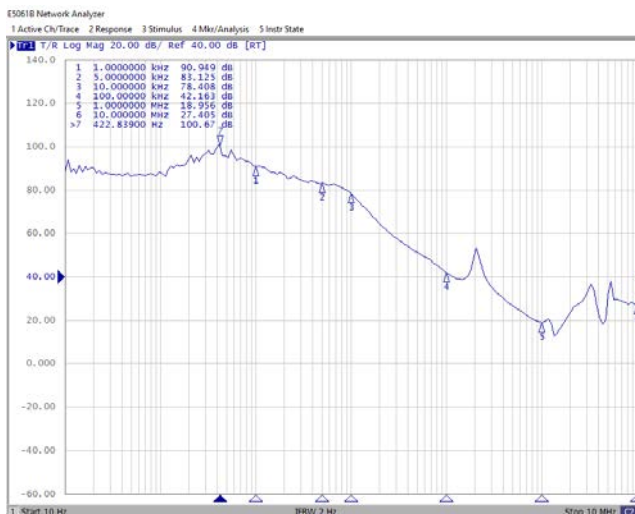

SUL6001D8-25

$I_{Load}=1mA$

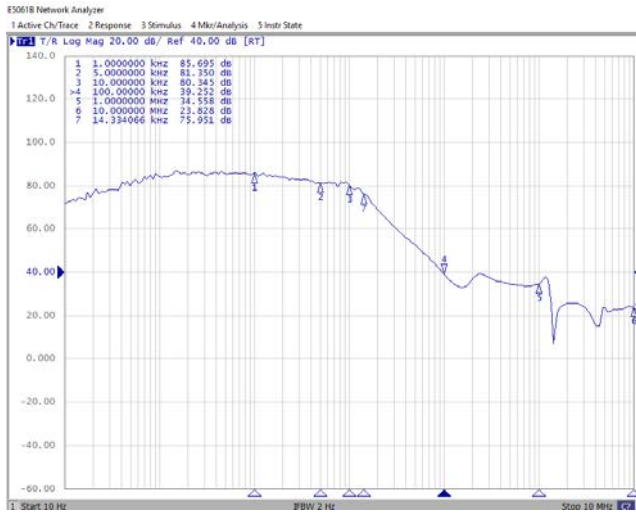

$I_{Load}=10mA$

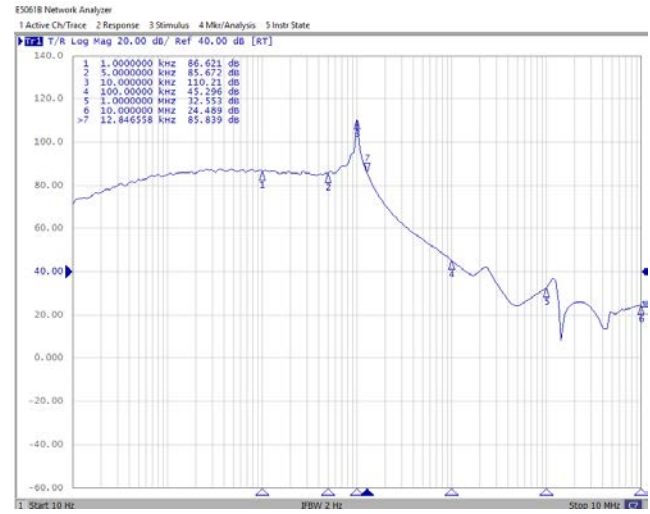

$I_{Load}=30mA$

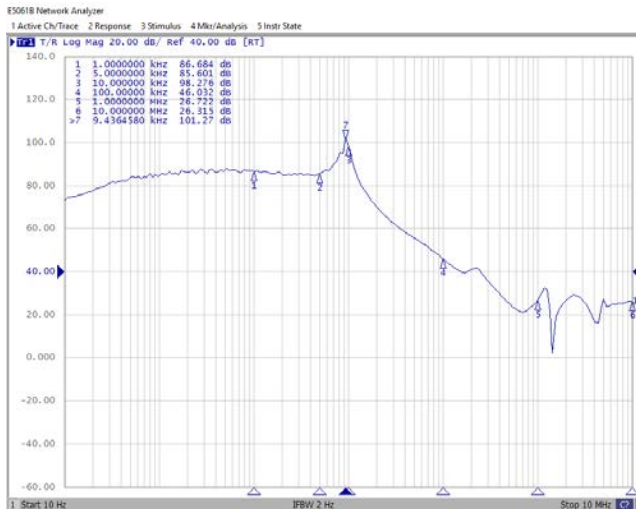

$I_{Load}=150mA$

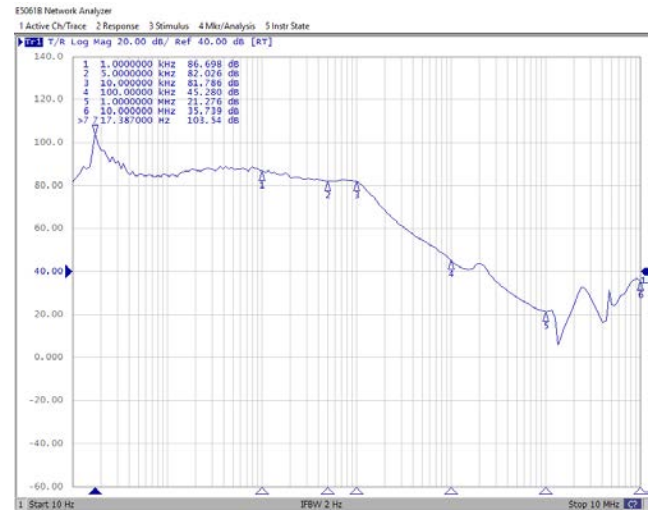

SUL6001D8-33

$I_{Load}=1mA$

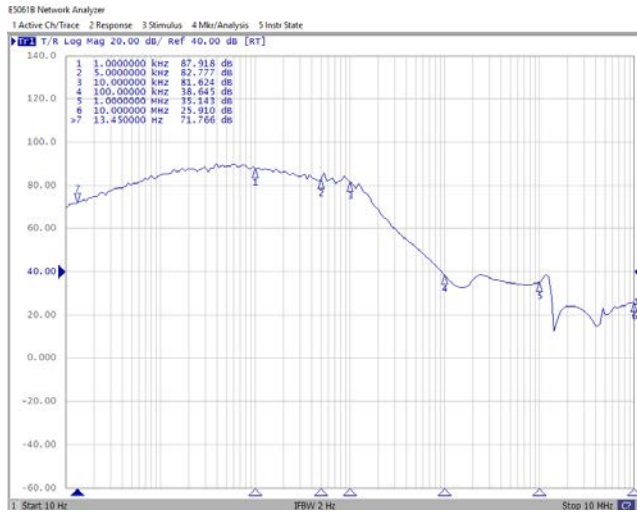

$I_{Load}=10mA$

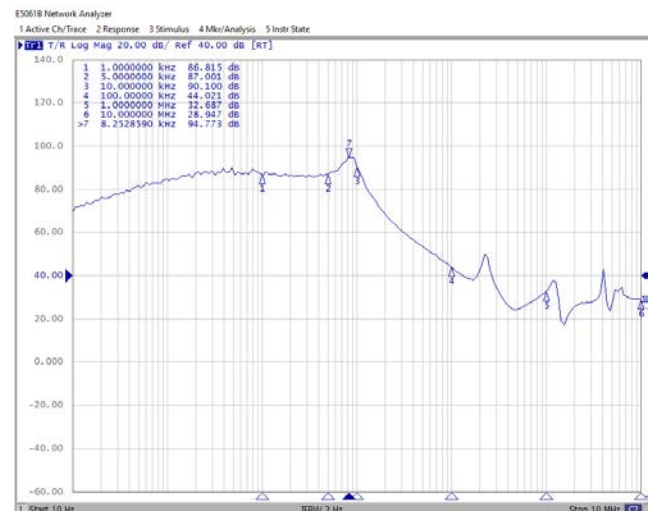

$I_{Load}=30mA$

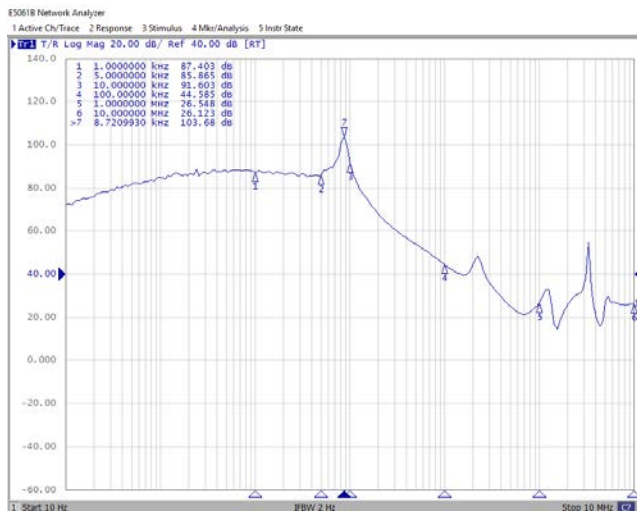

$I_{Load}=150mA$

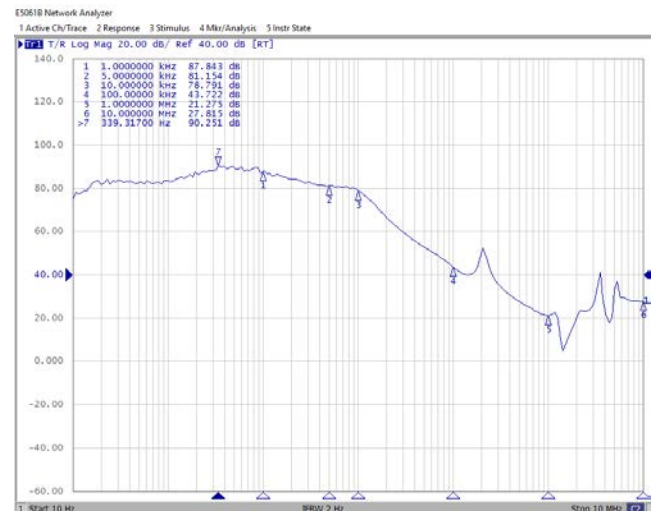

SUL6001D8-43

$I_{Load}=1mA$

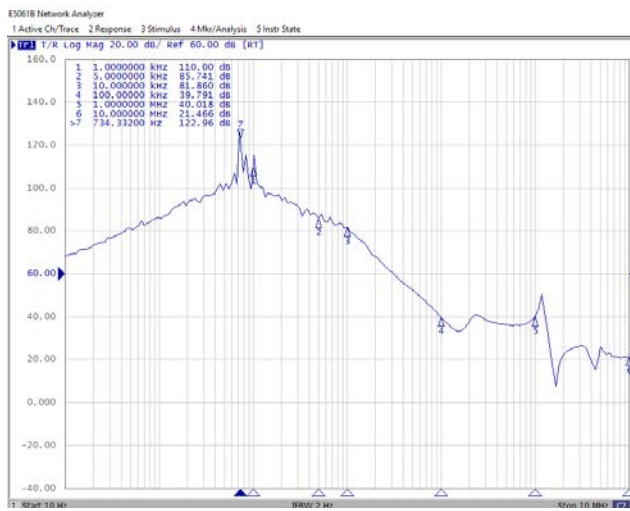

$I_{Load}=10mA$

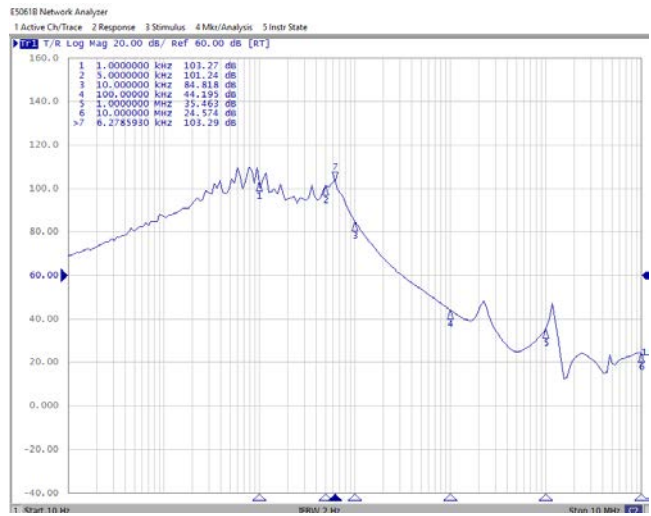

$I_{Load}=30mA$

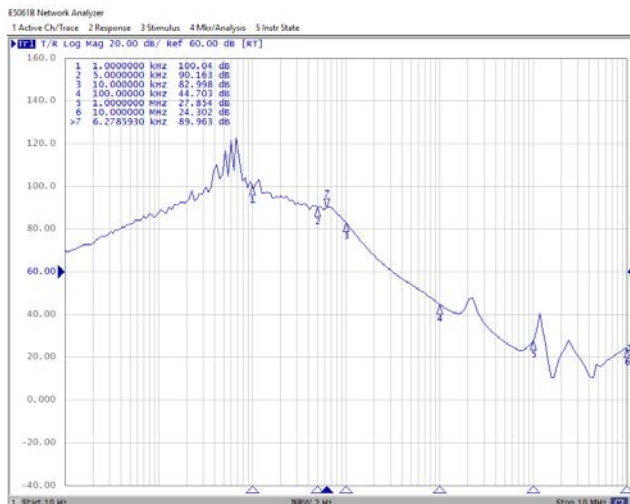

$I_{Load}=150mA$



Load Transient Response

($V_{IN}=V_{OUT}+1V$, $C_{IN} = C_{OUT} = 1.0\mu F$, $t_r = t_f = 1\mu s$, $T_a = 25^\circ C$)

SUL6001D8-090

1mA -> 250mA

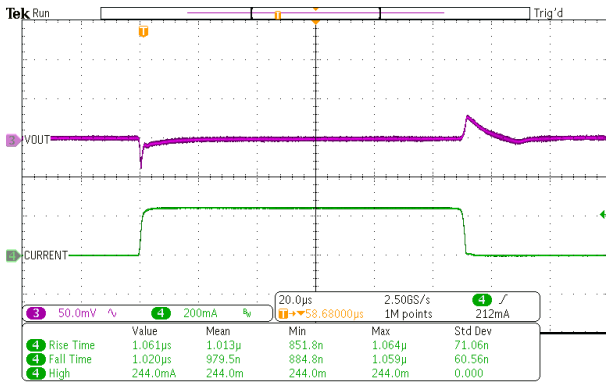

1mA -> 500mA

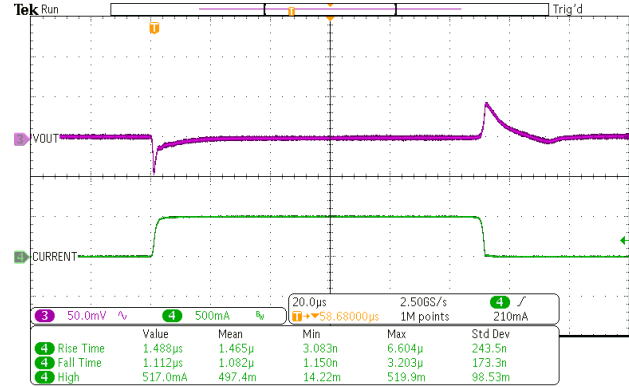

1mA -> 1000mA

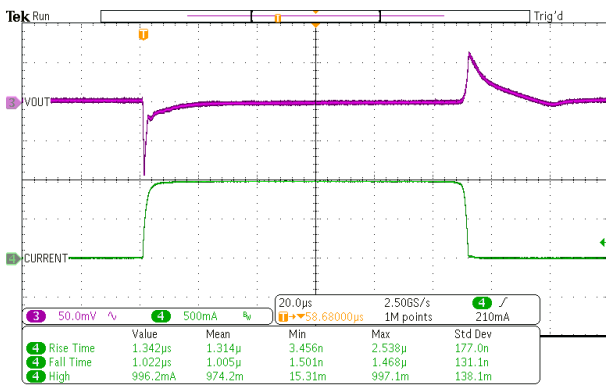

0mA -> 300mA

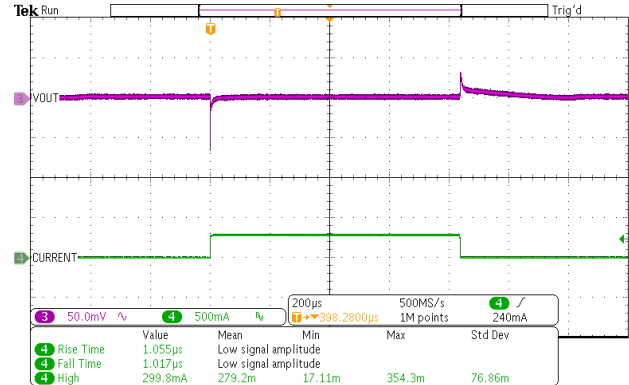

0mA -> 1000mA

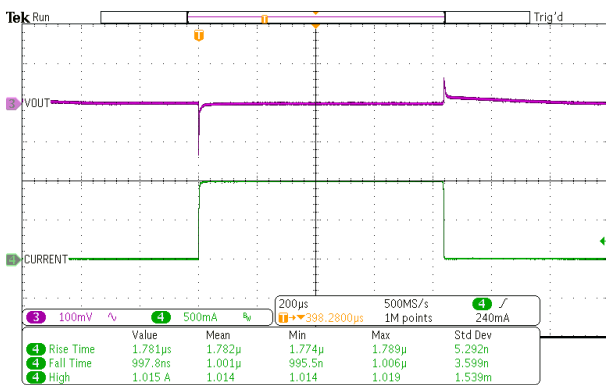

SUL6001D8-12

1mA -> 250mA

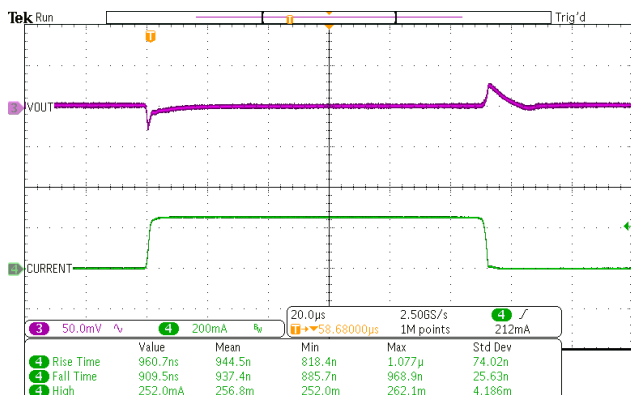

1mA -> 500mA

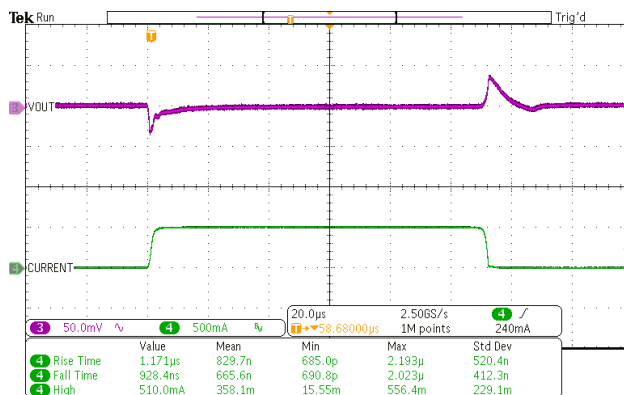

1mA -> 1000mA

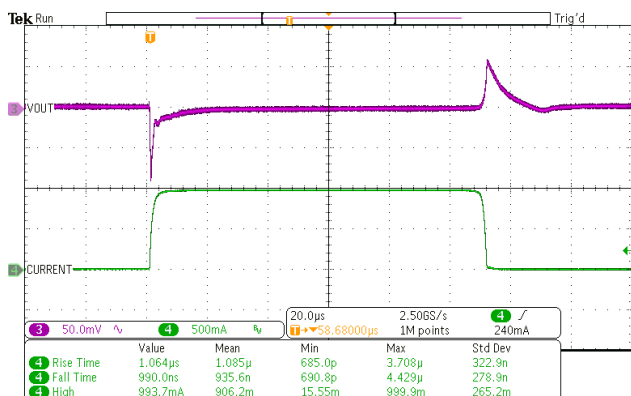

0mA -> 300mA

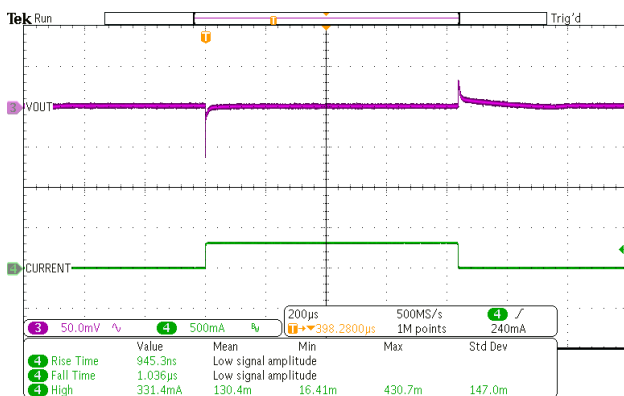

0mA -> 1000mA

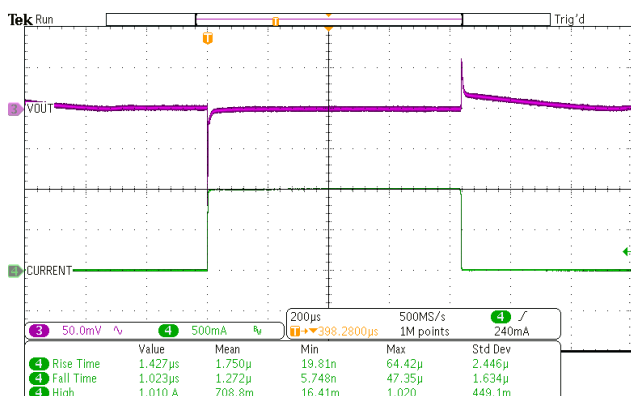

SUL6001D8-18

1mA -> 250mA

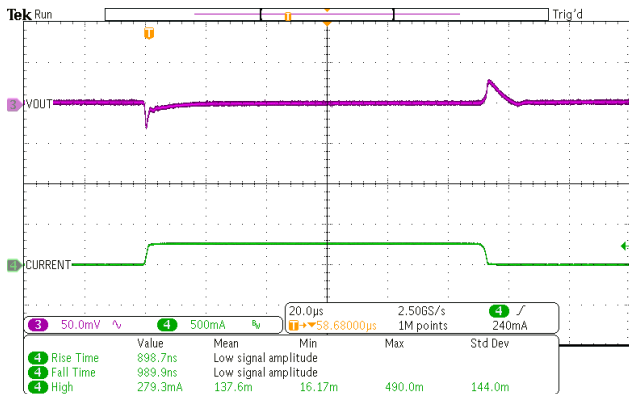

1mA -> 500mA

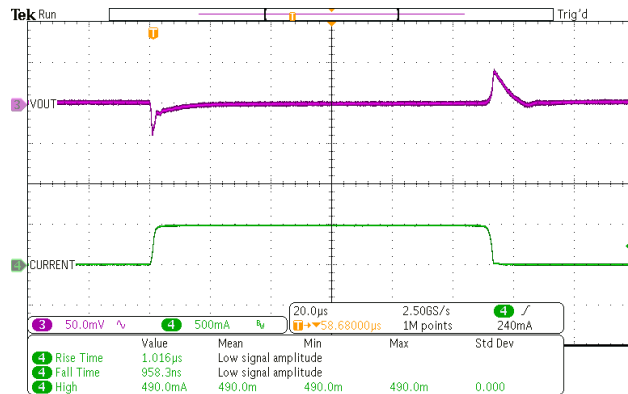

1mA -> 1000mA

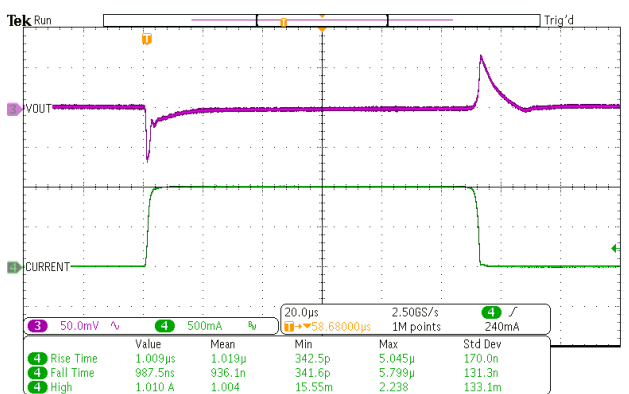

0mA -> 300mA

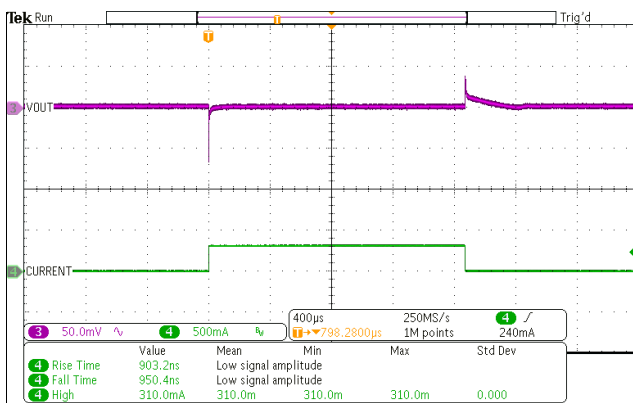

0mA -> 1000mA

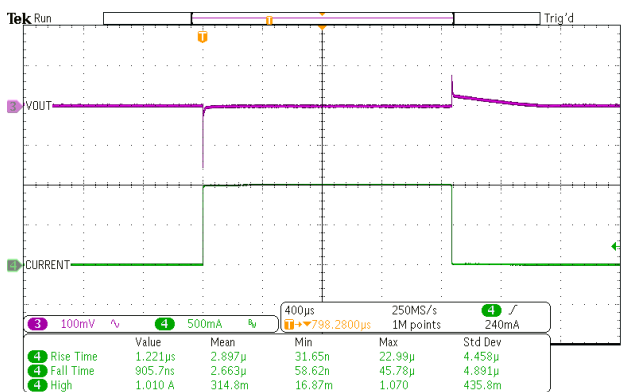

SUL6001D8-25

1mA -> 250mA

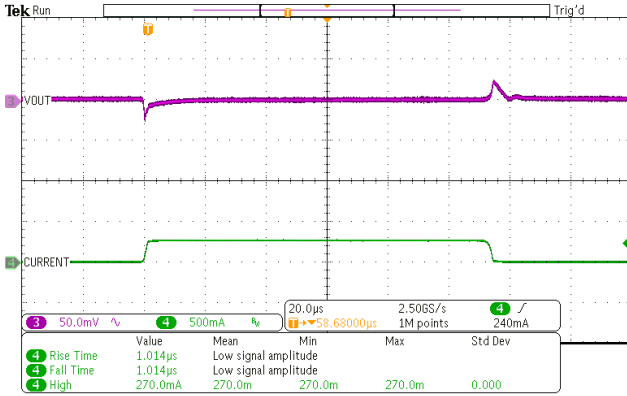

1mA -> 500mA

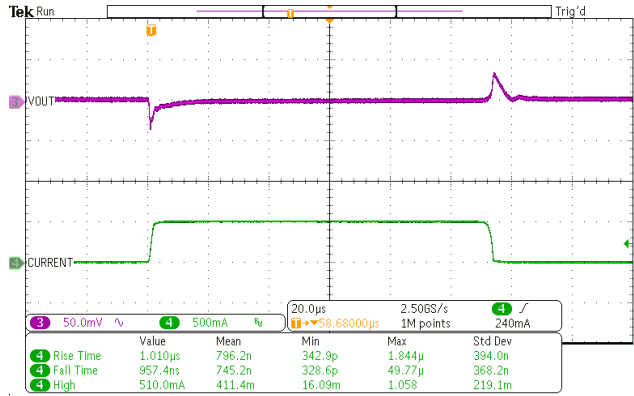

1mA -> 1000mA

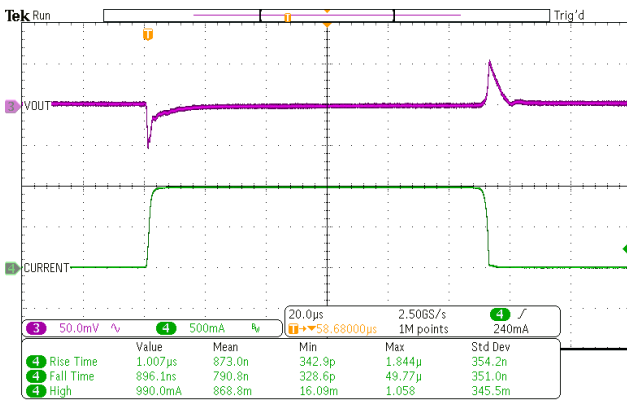

0mA -> 300mA

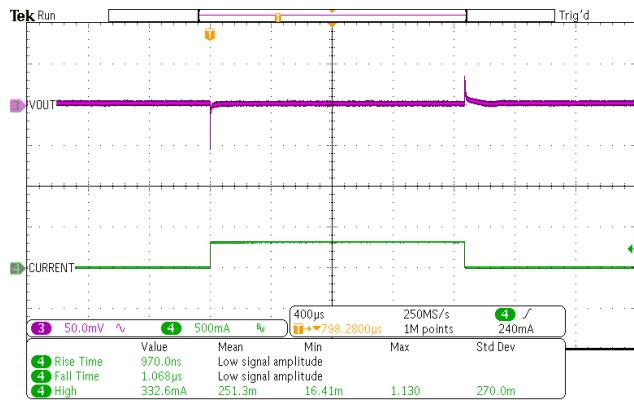

0mA -> 1000mA

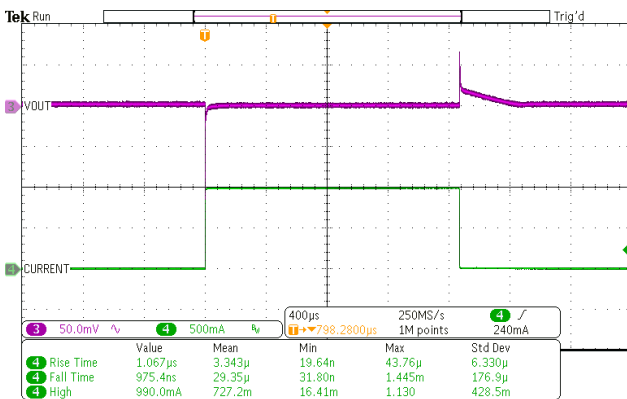

SUL6001D8-33

1mA -> 250mA

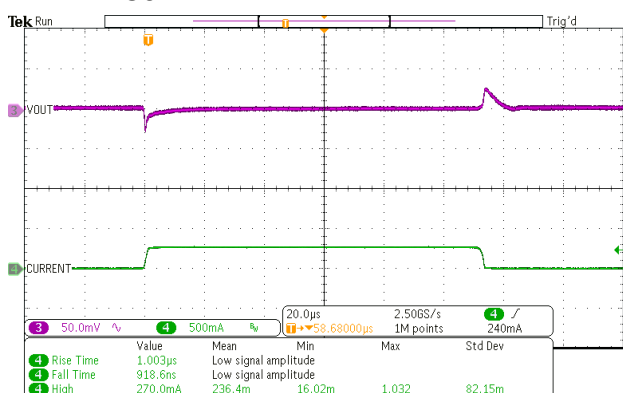

1mA -> 500mA

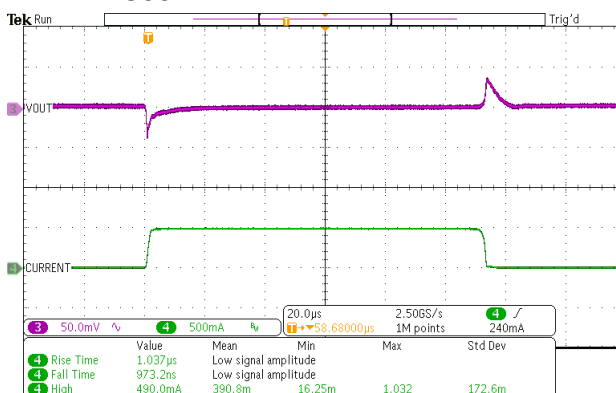

1mA -> 1000mA

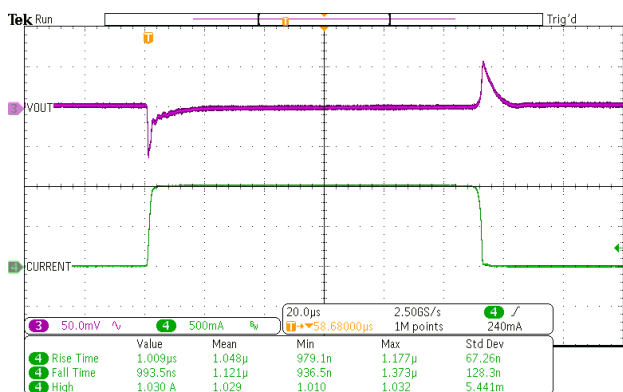

0mA -> 300mA

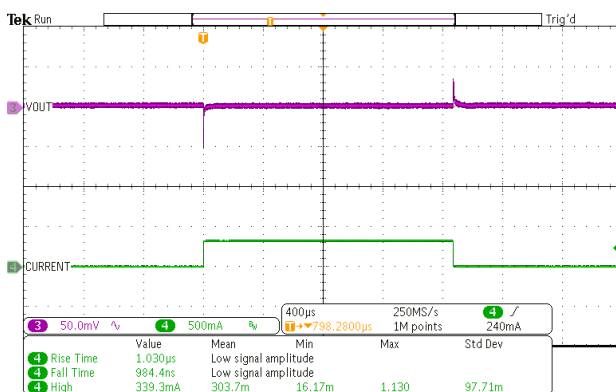

0mA -> 1000mA

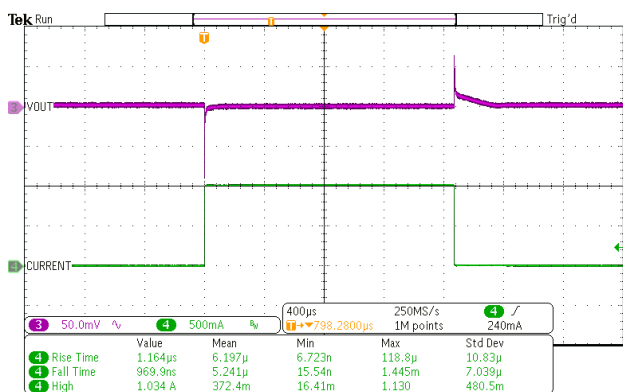

SUL6001D8-43

1mA -> 250mA

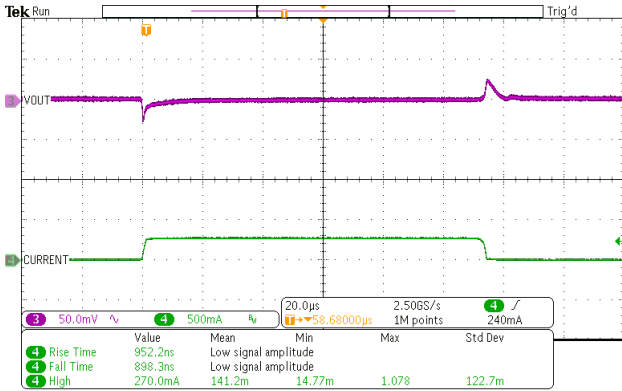

1mA -> 500mA

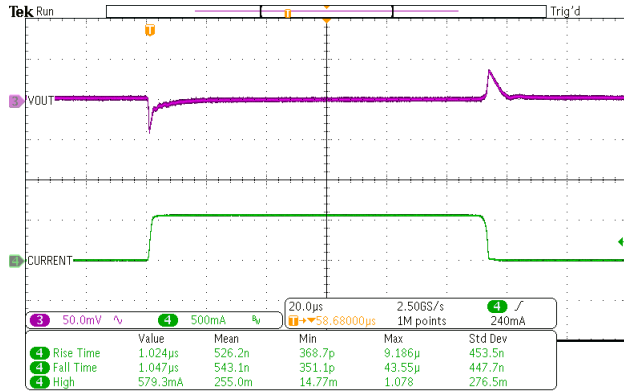

1mA -> 1000mA

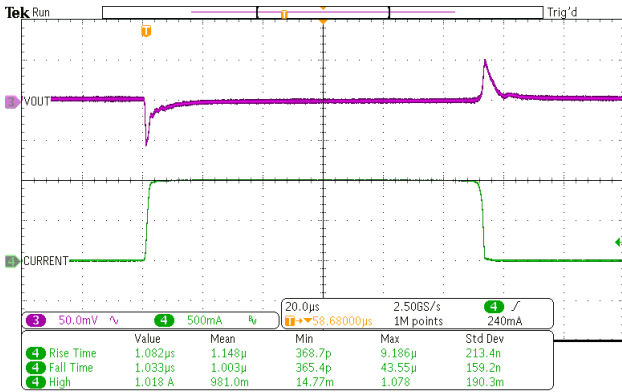

0mA -> 300mA

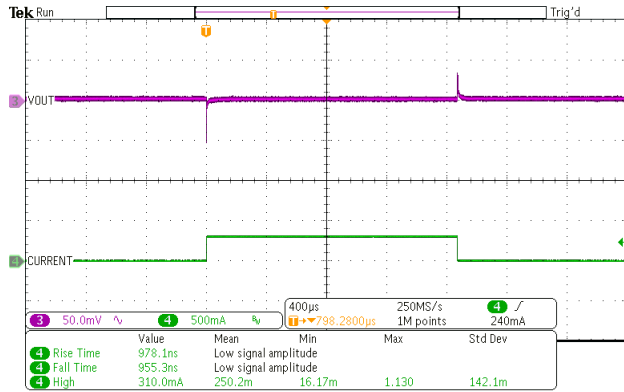

0mA -> 1000mA

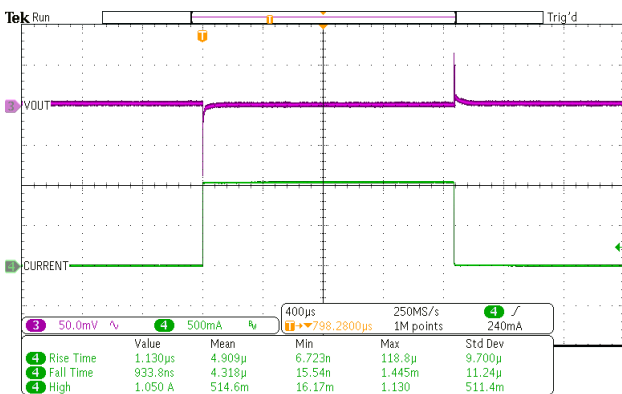

Turn-on waveform by V_{IN} & CE @ light load

($V_{IN} = CE = 0\text{ V}$ to $V_{OUT}+1\text{V}$, $C_{IN} = C_{OUT} = 1.0\ \mu\text{F}$, $T_a = 25^\circ\text{C}$, $I_{OUT} = 1\text{ mA}$)

SUL6001D8-090

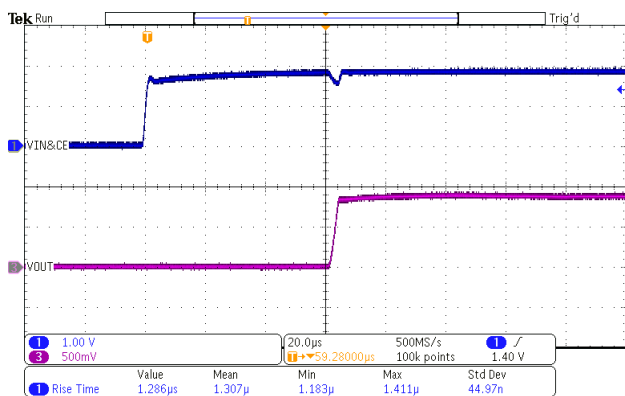

SUL6001D8-12

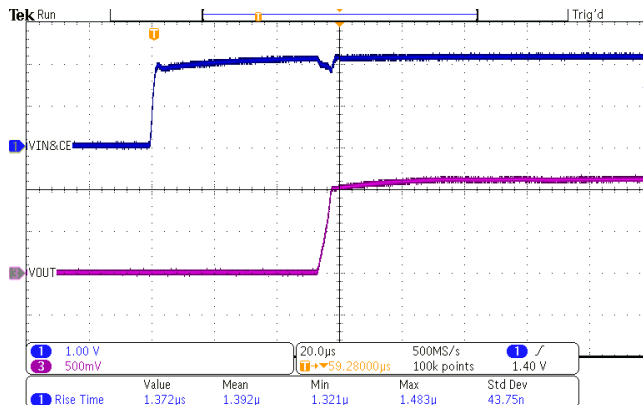

SUL6001D8-18

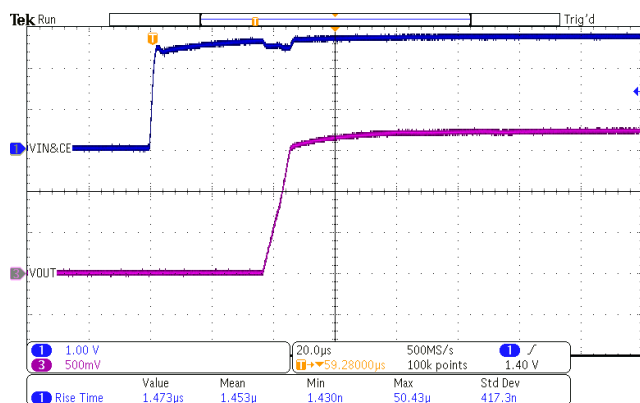

SUL6001D8-25

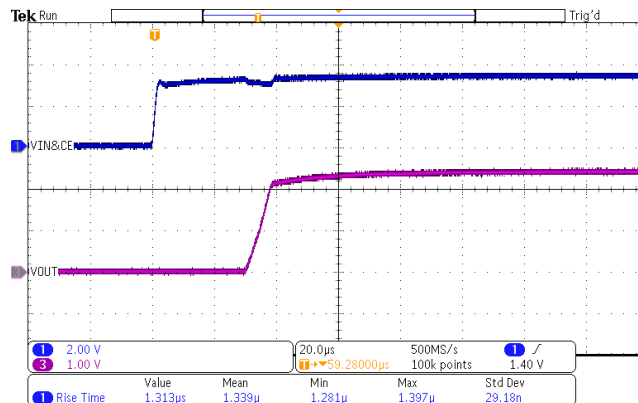

SUL6001D8-33

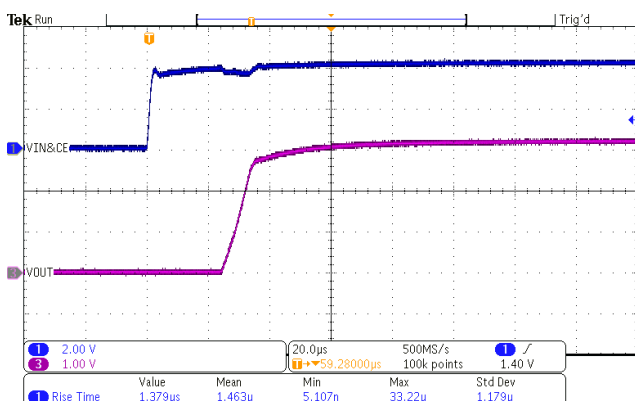

SUL6001D8-43

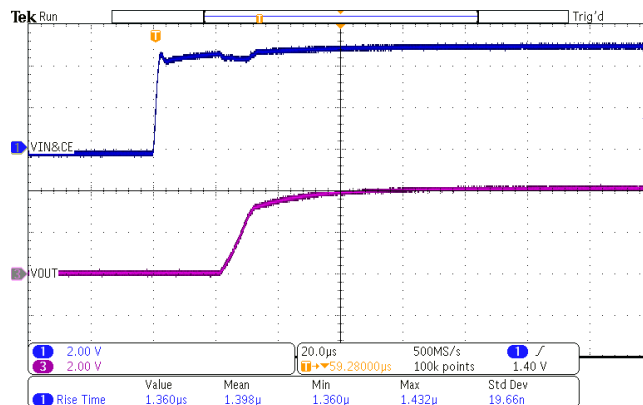

Turn-on waveform by VIN & CE @ full load

($V_{IN} = CE = 0V$ to $V_{OUT} + 1V$, $C_{IN} = C_{OUT} = 1.0\mu F$, $T_a = 25^\circ C$, $I_{OUT} = 1A$)

SUL6001D8-090

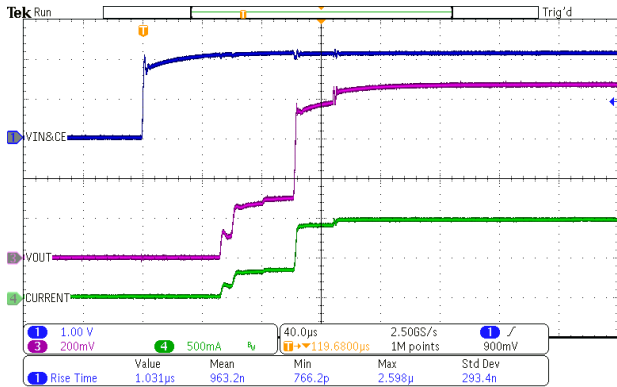

SUL6001D8-12

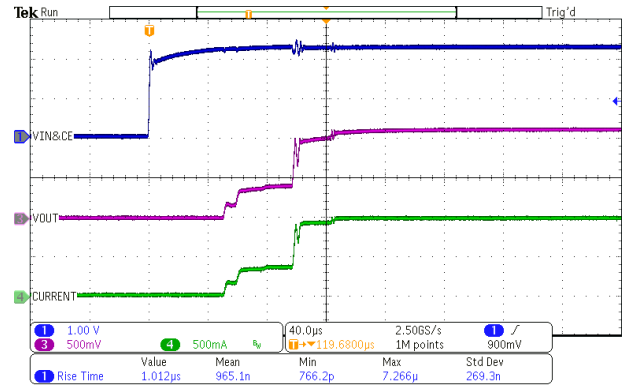

SUL6001D8-18

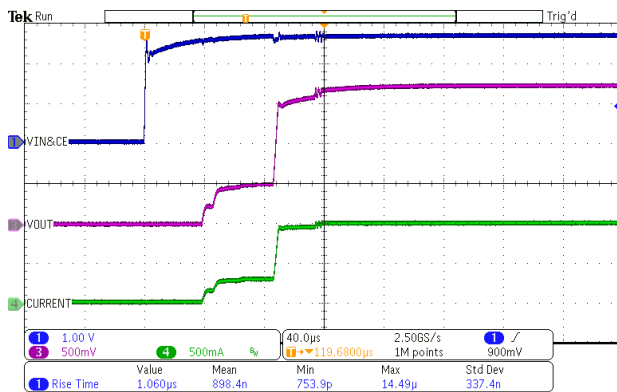

SUL6001D8-25

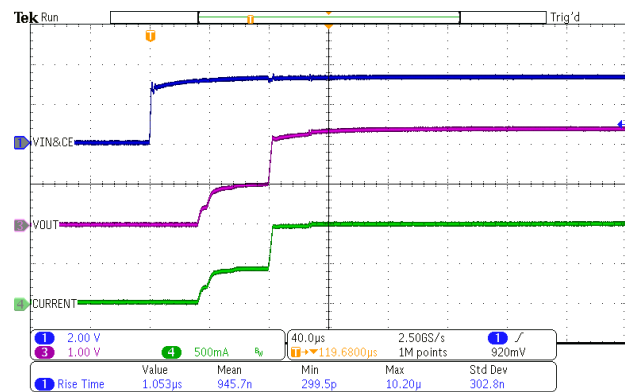

SUL6001D8-33

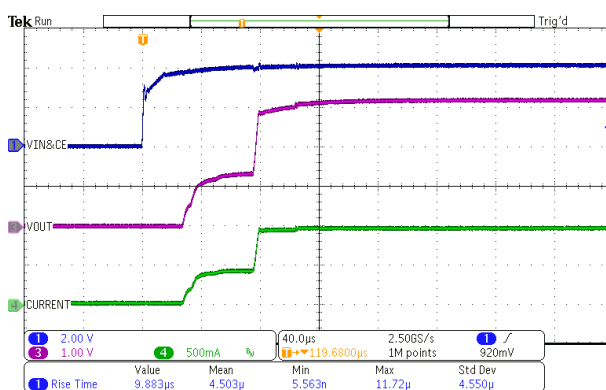

SUL6001D8-43

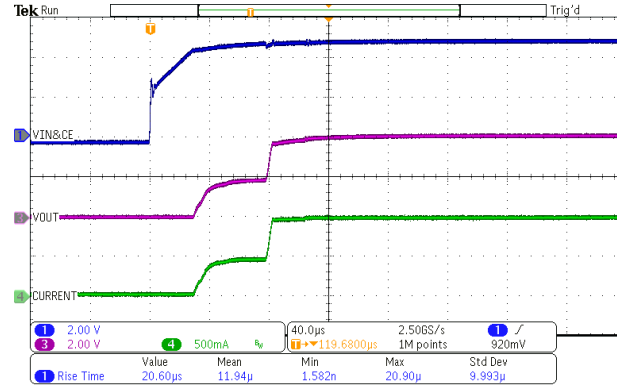

Turn-on by CE pin & Inrush current @ no load

($V_{IN} = V_{OUT} + 1V$, $CE = 0V$ to $1V$, $C_{IN} = C_{OUT} = 1.0\mu F$, $T_a = 25^\circ C$, $I_{OUT} = 0mA$)

SUL6001D8-09

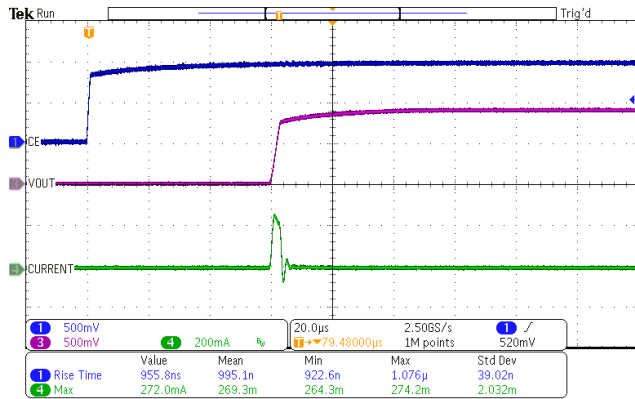

SUL6001D8-12

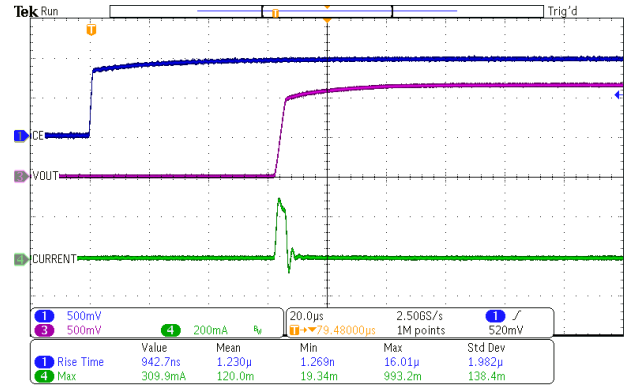

SUL6001D8-18

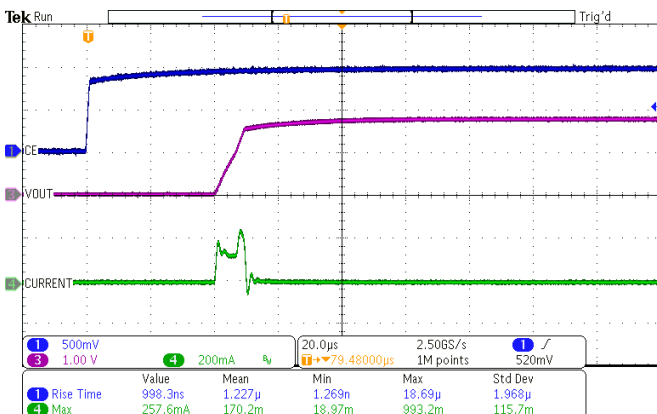

SUL6001D8-25

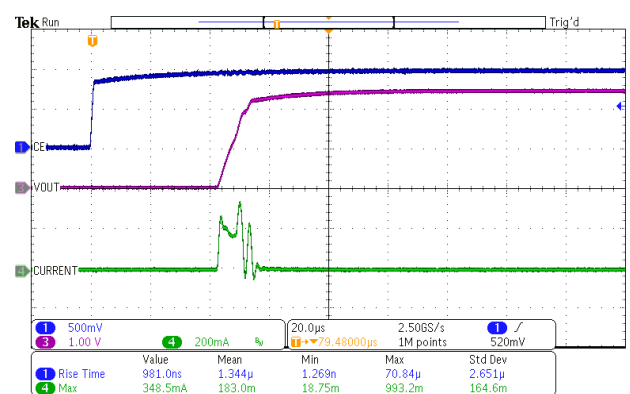

SUL6001D8-33

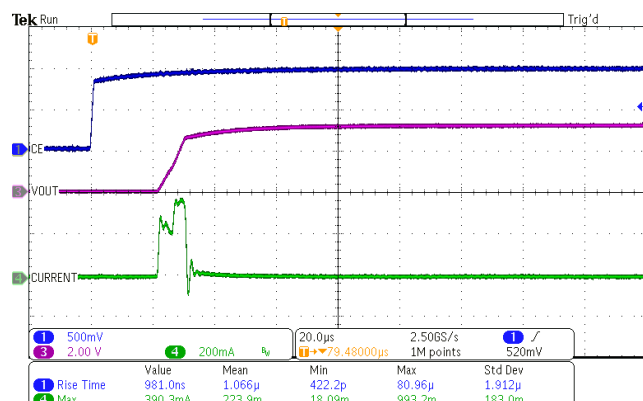

SUL6001D8-43

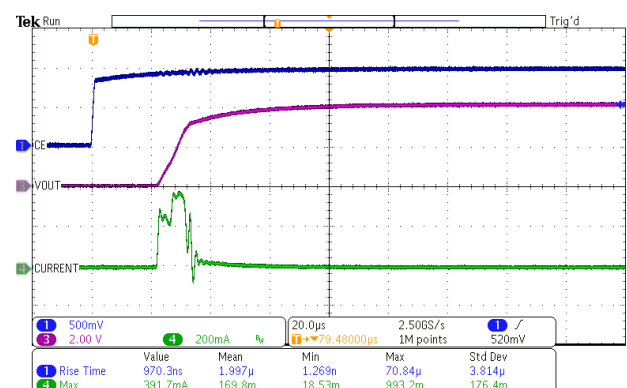

Turn-on by CE pin @ full load

($V_{IN} = V_{OUT} + 1V$, $CE = 0V$ to $1V$, $C_{IN} = C_{OUT} = 1.0\mu F$, $T_a = 25^\circ C$, $I_{OUT} = 1A$)

SUL6001D8-090

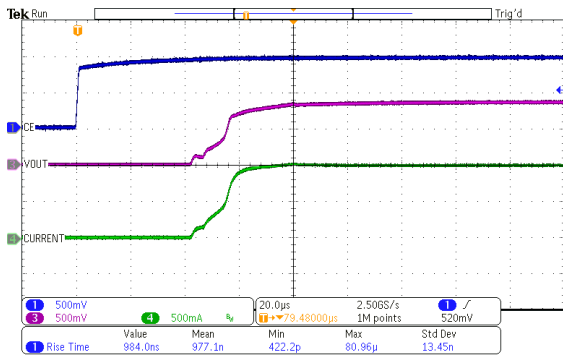

SUL6001D8-12

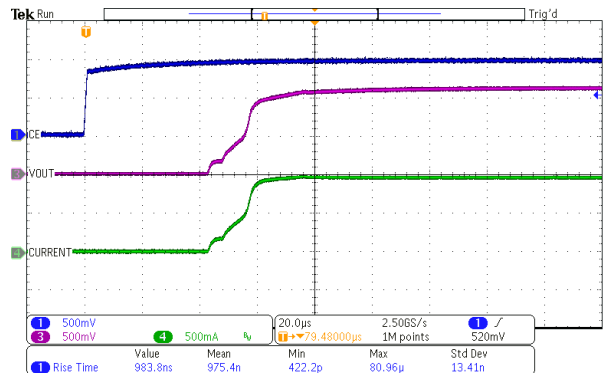

SUL6001D8-18

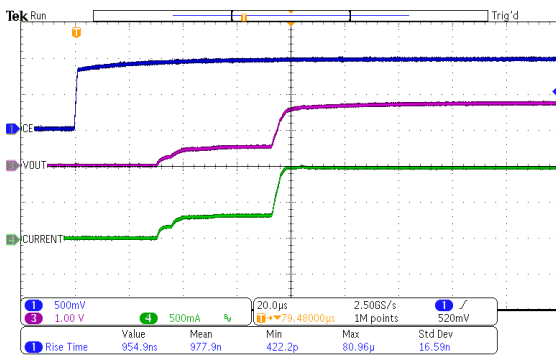

SUL6001D8-25

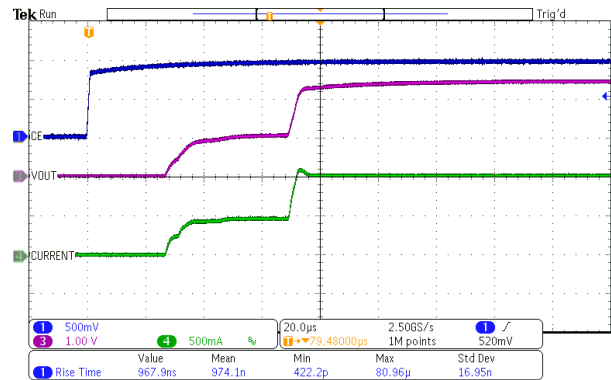

SUL6001D8-33

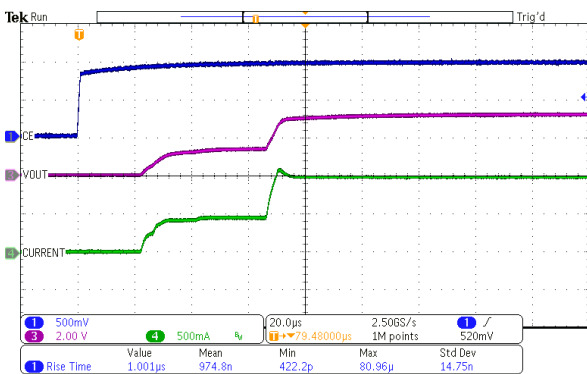

SUL6001D8-43

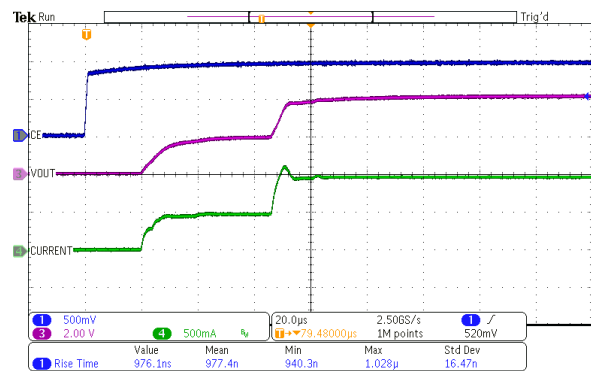

BLOCK DIAGRAMS

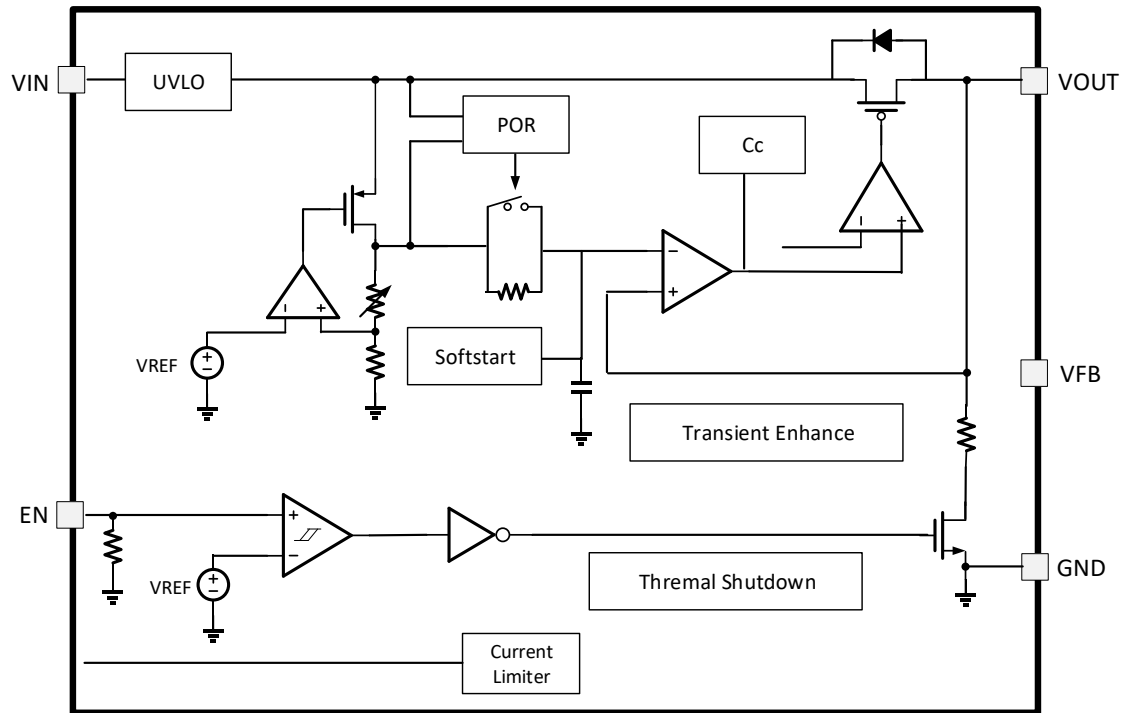

SOT23-5 Fixed Mode

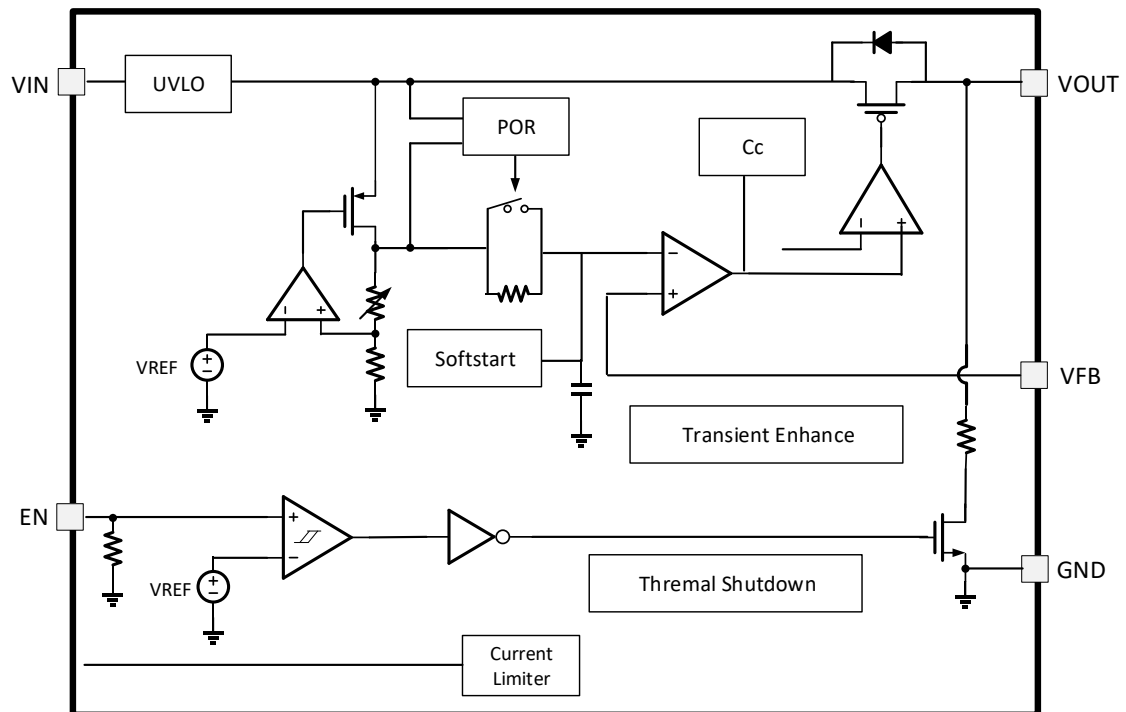

SOT23-5 ADJ Mode

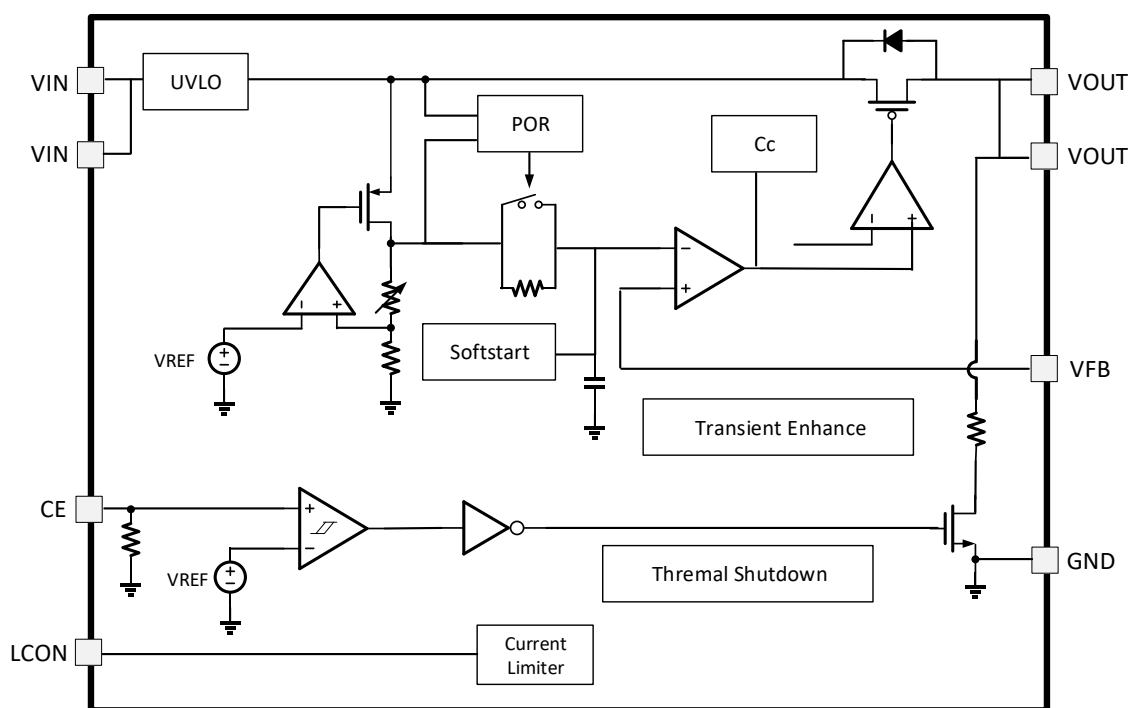

DFN1216-8 ADJ Mode

FUNCTION DESCRIPTION

Short-Circuit Protect and Current Limitation

SUL6001 series LDOs can protect internal circuit under short-circuit condition on the output. When the load current increases above 1.55A, the current limit and current foldback mechanism starts to restrict the I_{LIM} value. If the load resistance decreases even more then the foldback, circuit starts limiting the current to 0.2A when $V_{OUT} = 0$.

Over Temperature Protection and Auto Recover

In order to prevent over thermal condition from damaging the device, SUL6001 series LDOs have internal thermal limiting functions designed to protect the device. It will rapidly shut off PMOS pass element during over temperature condition.

Current Foldback

The current limiting/ current foldback circuit plays an important role by controlling any excessive output current. Our SUL6001 series LDOs provide a current foldback circuit that can detect accurately when an over-current condition occurs.

Very Fast Transient Response

In addition to the main feedback loop, SUL6001 series LDOs contain a fast-transient loop that allows the LDO to respond faster to large-output transients. SUL6001 series LDOs that contain this loop are better able to minimize the effects of a load transient even the output capacitance is small. The recommended output capacitance value is 1 μ F. It's small size greatly reduce the cost and save PCB area.

Ultra High PSRR and Extreme Low Noise

SUNTEK's SUL6001 series high-performance LDO regulators feature remarkable power supply rejection ratio characteristics (up to 104dB at 10kHz) and extreme-low noise operation (as low as 6.3 μ VRMS with A-wt) resulting in cleaner and stable output voltages. Our LDO is very suitable for ultra-sensitive loads like camera module and security monitor, especially in low light condition.

Start-Up at Full Load

SUL6001 series LDOs can start-up at full load, make it very suitable for heavy load start up condition and severe system timing constraint.

Auto Discharge Function

SUL6001 series LDOs have an auto discharge function to quickly force the output voltage to zero. When the LDO is disabled, the auto discharge function quickly discharge the output capacitor, thereby reducing the output voltage to nearly zero. This function is very useful for quickly ON/OFF application.

Low Quiescent Current

SUL6001 series LDOs consume only 85 μ A (typical) while operating with no load condition. By reducing the quiescent current, your application can stay in standby/sleep mode much longer than leading low quiescent current LDOs in the market.

Under Voltage Lock OUT (UVLO)

SUL6001 has an undervoltage lockout (UVLO) function to make sure that whole circuit does nothing until the power supply voltage is high enough. When power supply voltage is high enough, reference circuit can generate right voltage ; logic function can generate correct control signals. This UVLO function can guarantee robust system performance.

PACKAGE DIMENSION: DFN1216-8

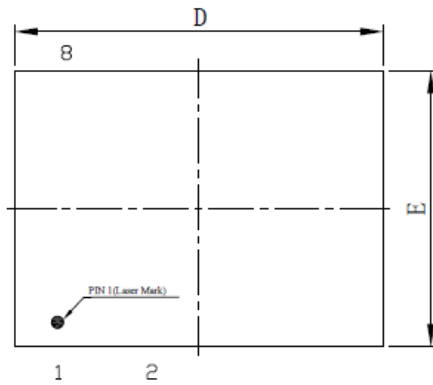

TOP VIEW

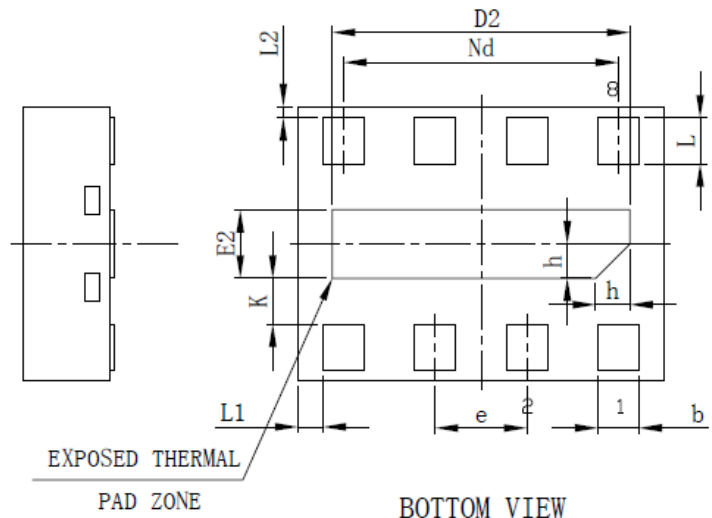

BOTTOM VIEW

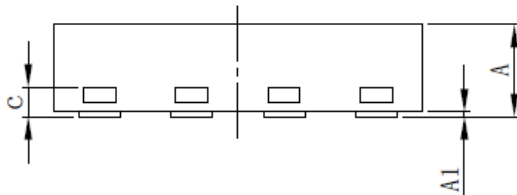

SIDE VIEW

SYMBOL	MILLIMETER		
	MIN	NOM	MAX
A	0.35	-	0.40
A1	0	0.02	0.05
b	0.13	0.18	0.23
c	0.127REF		
D	1.55	1.60	1.65
D2	1.25	1.30	1.35
e	0.40BSC		
Nd	1.20BSC		
E	1.15	1.20	1.25
E2	0.25	0.30	0.35
L	0.15	0.20	0.25
L1	0.06	0.11	0.16
L2	0.05REF		
h	0.10	0.15	0.20
K	0.15	0.20	0.25

PACKAGE DIMENSION: SOT-23-5

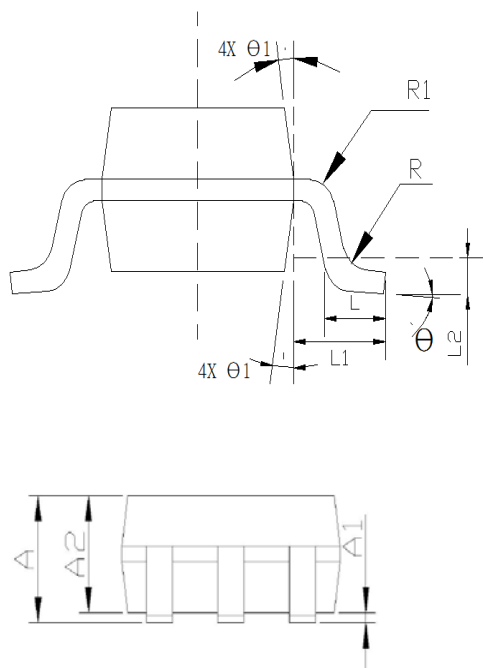
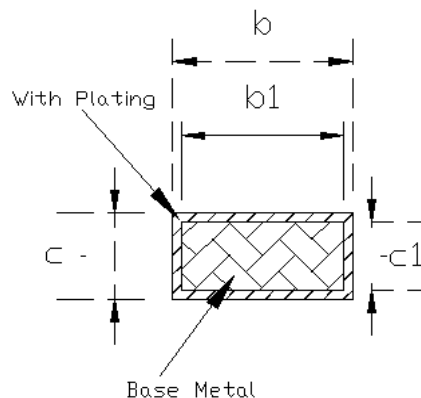
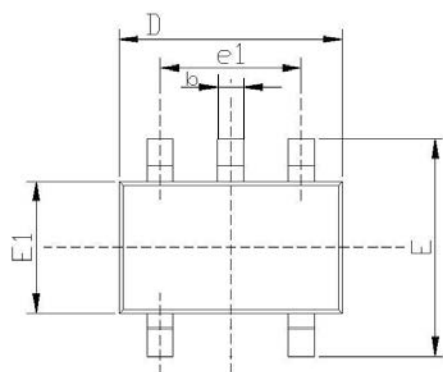

Common Dimensions (Units of Measure=Millimeter)			
SYMBOL	MINIMUM	NOMINAL	MAXIMUM
A	-	-	1.35
A1	0	-	0.15
A2	1.00	1.10	1.20
b	0.35	-	0.45
b1	0.32	-	0.38
c	0.14	-	0.20
c1	0.14	0.15	0.16
D	2.82	2.92	3.02
E	2.60	2.80	3.00
E1	1.526	1.626	1.726
e	0.90	0.95	1.00
e1	1.80	1.90	2.00
L	0.35	0.45	0.60
L1	0.6 REF		
L2	0.25 REF		
R	0.10	-	-
R1	0.10	-	0.25
θ	0°	4°	8°
$\theta 1$	5°	10°	15°

NOTES:

1. All dimensions refer to standard.
2. Dimensions D does not include mold FLASH.
3. Dimensions E1 does not include mold FLASH.
4. FLASH or protrusion shall not exceed 0.25mm per side. .

PACKAGE DIMENSION: DFN2x2-6

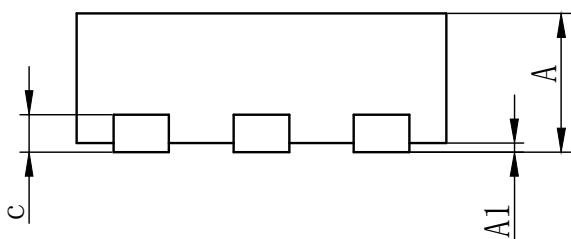
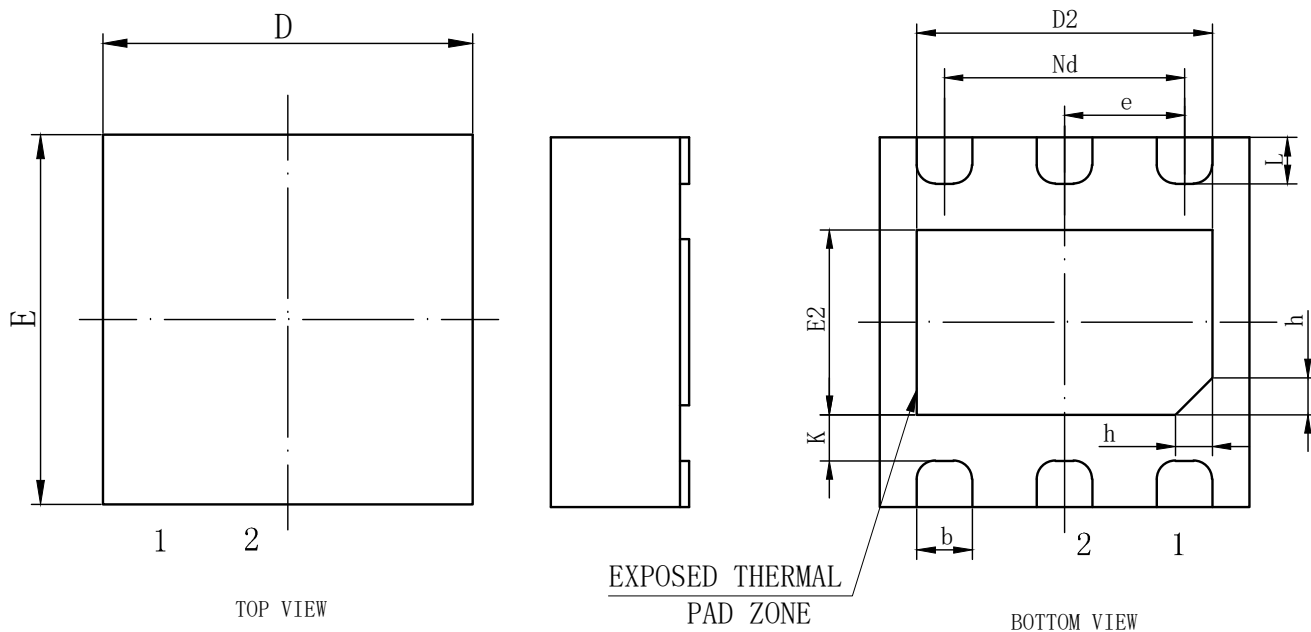

SYMBOL	MILLIMETER		
	MIN	NOM	MAX
A	0.70	0.75	0.80
	0.85	0.90	0.95
A1	0	0.02	0.05
b	0.25	0.30	0.35
c	0.18	0.20	0.25
D	1.90	2.00	2.10
D2	1.50	1.60	1.70
e	0.65BSC		
Nd	1.30BSC		
E	1.90	2.00	2.10
E2	0.90	1.00	1.10
K	0.20	-	-
L	0.20	0.25	0.30
h	0.15	0.20	0.25
L/F载体尺寸 (MIL)	69X47/71X47		

PACKAGE DIMENSION:DFN3x3-8

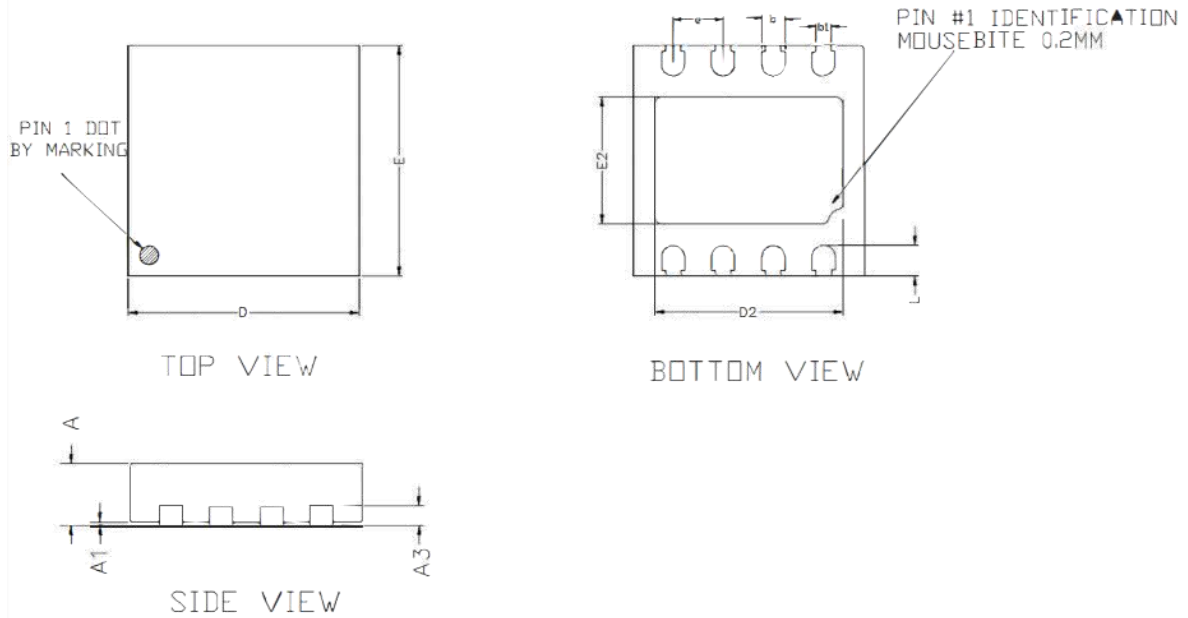

COMMON DIMENSIONS(MM)			
PKG.	W:VERY VERY THIN		
REF.	MIN.	NOM.	MAX
A	0.70	0.75	0.80
A1	0.00	—	0.05
A3	0.2 REF.		
D	2.95	3.00	3.05
E	2.95	3.00	3.05
b	0.25	0.30	0.35
L	0.30	0.40	0.50
D2	2.40	2.45	2.50
E2	1.60	1.65	1.70
e	0.65 BSC		
b1	0.20		