

NOTE1:

1.MATERIAL SPECIFICATION:

- 1.HOUSING:HIGH TEMPERATURE RESISTANT PLASTIC,
- 2.CONTACTS: COPPER ALLOY
- 3.MID PLATE: STAINLESS STEEL
- 4.FRONT SHELL: STAINLESS STEEL

2.PLATING SPECIFICATION:

2-1.CONTACTS:

Ni 50u" MIN. UNDER PLATED OVER ALL.

Au PLATED ON THE FUNCTIONAL AREA OF CONTACT.

(GOLD PLATING THICKNESS FOLLOW THE P/N)

PLATING SPECIFICATIONS OF THE SOLDER AREA FOLLOW THE P/N

2-2.FRONT SHELL:

SEE TABLE1.

2-3.SHIELD PLATE&EMI PLATE:

CLEAR ONLY

3.MECHANICAL PERFORMANCE,

3-1.INSERTION FORCE: 0.5~2.0kgf.

3-2.REMOVAL FORCE: 0.8kgf~2.0kgf.

3-3.DURABILITY: 2000 CYCLES.

4.ELECTRICAL PERFORMANCE,

4-1. CURRENT RATING:3.0A

VOLTAGE RATING:5.0V

4-2. LLCR:

VBUS & GND PINS AND OTHER PINS: 40mΩ/PIN MAX.

SHIELD: 50mΩ/MAX.

LLCR MAX. CHANGE OF ALL PINS: 10mΩ

4-3.INSULATION RESISTANCE: 100MΩ MIN

4-4.DIELECTRIC WITHSTAND VOLTAGE,AC 100V FOR 1 MINUTE.

5. ENVIRONMENTAL PERFORMANCE:

OPERATING TEMPERATURE: -25°C~+85°C.

6.IR REFLOW:

THE PEAK TEMPERATURE ON THE BOARD SHALL

BE MAINTAINED FOR 10 SECONDS AT 260°C.

7.COMPLY WITH RoHS 2.0 AND REACH AND OTHER ENVIRONMENTAL

PROTECTION REQUIREMENTS

8.带" Z"符号为重点管控尺寸

带" *"符号为通检管控尺寸

带" CPK"符号为CPK 管控尺寸

深圳市虹成电子有限公司

名称

TITLE:

6PIN TYPE C 板上型贴板母座(外壳全贴)

料号 PART NO.

HC-TYPE-C-6P-012A

SCALE

1:1

UNIT:mm

A4

☉ □

SHEET:

					General	Angle	设计		
					X±0.25	X'±3'	DESIGN		
					.X±0.20	.X'±2'	校阅		
					.XX±0.15	.XX'±1'	CHECK		
					.XXX±0.08		承认		
					GENERAL TOLERANCE UNLESS OTHERWISE NOTED		APPRO.		
工程变更通知单号 ECN NO.	版次 REV	NEW 说明 DESCRIPTION	何平 改变 CHANGE	2021.05.22 日期 DATE					

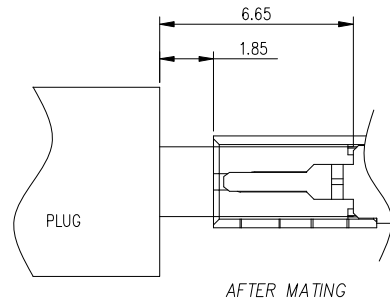

USB TYPE-C PIN ASSIGNMENTS

PIN NUMBER	SIGNAL NAME	PIN NUMBER	SIGNAL NAME
A12	GND	B12	GND
A9	V BUS	B9	V BUS
A5	CC1	B5	CC2

ORDER INFORMATION

P / N: TC02-006F W1_04 B T1 L	
	PACKING
	L: REEL WITHOUT CAP
	R: REEL WITH CAP
	SHELL PLATING
	T1: Ni 50u"Min
	HOUSING COLOR
	A: WHITE
	B: BLACK
	CONTACT PLATING
	W1: Au 1u" and Tin 40~80u"

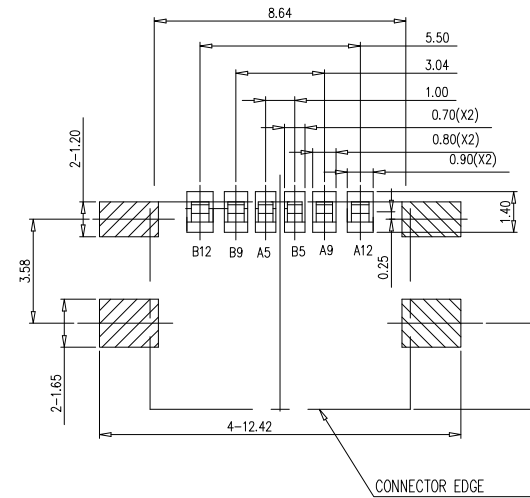

RECOMMENDED PCB LAYOUT(TOP VIEW)

THICKNESS 1.6±0.10MM;DEFAULT TOLERANCE:±0.05

深圳市虹成电子有限公司

					General	Angle	设计		
					X±0.25	X°±3'	DESIGN		
					.X±0.20	.X°±2'	校阅		
					.XX±0.15	.XX°±1'	CHECK		
					.XXX±0.08		承认		
					GENERAL TOLERANCE UNLESS OTHERWISE NOTED		APPRO.		
工程变更通知单号 ECN NO.	版次 REV	NEW	何平	2021.05.22					
		说明 DESCRIPTION	改变 CHANGE	日期 DATE					

名称 TITLE: 6PIN TYPE C 板上型贴板母座(外壳全贴)			
料号 PART NO.		HC-TYPE-C-6P-012A	
SCALE	1:1	UNIT:mm	A4 SHEET: