



# 承 认 书

品名： 圆片陶瓷电容器

ITEM: Ceramic Disc Capacitors

制造 MANUFACTURER			客户 CUSTOMER		
拟制 DESIGN	审核 CHECK	批准 APPROVAL	检验 INSPECTOR	审核 CHECK	批准 APPROVAL
陈健业	张锦洪	李际勇			

公司名称：广东风华高新科技股份有限公司正华陶瓷电容器分公司

Company name: Guangdong Fenghua Advanced Technology Holding CO.,LTD  
ZhengHua Ceramic Disc Capacitor Branch Company

地 址：广东省肇庆市端州一路工业城 110 号

Address : (Multiple function building),Block 110,Industrial Zone,Duanzhou Ist Road,Zhaoqing City,Guangdong,P.R.China

电话 (Telephone) :0758-6923812 邮编 (Zip code) :526060



# 圆片瓷介电容器 Ceramic Disc Capacitor

## 文件修订履历表

修订编号	修订页码	修订摘要	修订日期	修订人	审核人
A	-	编制	-	张锦洪	李际勇
B	-	修改可靠性试验项目，产品存储期限描述，增加相关使用注意事项	2023.4.7	黄晓雯	庞溥生



# 圆片瓷介电容器 Ceramic Disc Capacitor







客户 Customer name: 福昌辉科技

产品规格栏 Product specifications											
客户代码 Customer code					风华型号 Fenghua models						
(1)					(1) CT7-Y6Y5P3E471KSEAB5						
(2)					(2) CT81M6Y5P1D681KSEAT0						
(3)					(3) CT81P12Y5V1D103MSEAT0						
(4)					(4) CT81M8Y5V3D472MSEAB5						
NO	额定电压 Voltage	标称容量 Capacitance	容量 偏差 Tolerance	温度 特性 T.C.	成品外形尺寸 Overall dimensions of finished products(mm)					脚型 Foot type - 包装 Packing	产品标识 Product identification
					直径 Diameter (D)	厚度 Thickness (T)	引线 线径 Φ (d)	脚长 Length (H0)	间距 Lead spacing (F)		
1	400V AC	470 pF	± 10%	Y5P	9.0 Max	6.0 Max	0.60 ± 0.08	3.5 ± 0.5	10.0 ± 0.50	Straight ~ Bulking	CT7-Y1  B471K 400~
2	2KV DC	680 pF	±10%	Y5P	9.0 Max	4.0 Max	0.60 ± 0.08	17 min	7.50 ± 0.50	Straight ~ Bulking	 B681K 2KV
3	3KV DC	10000 pF	±20%	Y5V	15.0 Max	5.0 Max	0.60 ± 0.08	17 min	7.50 ± 0.50	Straight ~ Bulking	 F103M 3KV
4	2KV DC	4700 pF	±20%	Y5V	11.0 Max	4.0 Max	0.60 ± 0.08	3.5 ± 0.5	7.50 ± 0.50	Straight ~ Bulking	 F472M 2KV
附注											



# 圆片瓷介电容器 Ceramic Disc Capacitor

## 安规认证清单表 Safety Certification List

产品系列 Series	CT7 安规（交流）系列产品 CT7 Alternating current disk ceramic capacitor			
证书名称 Certificate name	认证标志 Certification Mark	认证标准 Certification Standard	Y1 系列 Y1-Series	Y2 系列 Y2-Series
中国 CQC		GB/T6346.14-2015	CQC03001007930	CQC03001007929
德国 VDE		IEC 60384-14 (ed.4)	40013874	40013869
美国 UL		IEC 60384-14 (ed.4)	E219015	
CB 证书	—	EN 60384-14:2013 /AMD1:2016	DE1-62035	DE1-62042
瑞士 SEV		IEC 60384-14 (ed.4) : 2013	19.0469	19.0470
瑞典 SEMKO		EN 60384-14:2013	1911979	1911982
挪威 NEMKO		IEC 60384-14: 2013	P19223835	P19223836
丹麦 DEMKO		EN 60384-14:2013	D-06110-M1	D-06111-M1
芬兰 FIMKO		EN 60384-14:2013 +AMD1:2016	FI/40255	FI/40256
韩国 Korea		KC 60384-1 (2015-09) KC 60384-14 (2015-09)	SU03101-17002	SU03101-17001



# 圆片瓷介电容器 Ceramic Disc Capacitor

## 1、选型参考 Type selection reference

产品类型 Product Type	主要用途 Main Application
CC81—I类温度补偿型 CC81 - Class I temperature compensation type	用于要求损耗值小、容量稳定性要求较高的电路中：谐振回路、高频旁路、温度补偿、控制电路的时间常数元件、稳定性要求高的耦合元件。 Loss value for small and high capacitance stability circuit: the resonant circuit, high-frequency bypass, temperature compensation and control time constant of the circuit components, high stability requirements of coupling components.
CT81—II类高介电常数 CT81 - Class II high dielectric constant	用于对损耗值和容量稳定性要求不高的电路中，如低频旁路、耦合、滤波、退耦等，时间常数元件。 Used for loss value and volume stability of circuits, such as low frequency, by-pass, coupling, filtering, decoupling, etc., the time constant of components.
CT7—交流 CT7-Alternating current	交流瓷介电容器适于在电子设备中作为跨电源线连接、天线耦合和旁路等。 In ac ceramic capacitor is suitable for electronic equipment as the power cord connection and antenna coupling and bypass, etc
备注：要注意产品类别、材质类别、电压级别、容量级别、外形尺寸的选择。 Note: Pay attention to the product category and material category, the choice of voltage level, capacity level, appearance size.	

## 2、注意事项 Points to note

瓷介电容器的静电容量易受温度影响，由后面的温度特性曲线可知道：I类产品的容量受温度影响相对偏小，II类、III类产品容量受温度影响呈非线性变化，因此进行容量测试前要把产品在国标规定的标准测试条件  $25 \pm 2^\circ\text{C}$  的环境下放置 2~4 小时后再进行测试。

The electrostatic capacity of ceramic capacitors is easily affected by temperature. From the following temperature characteristic curve, it can be seen that the capacity of Class I products is relatively less affected by temperature, and the capacity of Class II and III products changes nonlinearly due to temperature. Therefore, before carrying out the capacity test, the products should be placed under the standard test condition of  $25 \pm 2^\circ\text{C}$  specified in the national standard for 2-4 hours before the test.

## 3、使用温度范围 Operating temperature range :

3.1 国标 (GB) :  $-25^\circ\text{C} \sim +85^\circ\text{C}$

3.2 我公司承认 My company admits:  $-25^\circ\text{C} \sim +125^\circ\text{C}$

## 4、应用领域 Application field

广泛适用于家电、照明、通讯、网络、汽车电子等设备中。

Widely used in household appliances, lighting, communications, networking, automotive electronics and other equipment.



# 圆片瓷介电容器 Ceramic Disc Capacitor

## 5、型号构成 Part numbers

编码 Coding	CT7	Y	6	Y5P	3	E	471	K	S	E	A	B5
段数 Segment number	(1)	(2)	(3)	(4)	(5)	(6)	(7)	(8)	(9)	(10)	(11)	(12)
											厂商内部代码 Manufacturer's internal code	



段数 Segment number	项目 Projects	编码 Coding
(1)	产品类型 Product Type	N0: 1~4
(2)	额定电压及代码 Rated Voltage and the code	N0: 5
(3)	直径代码 Diameter Code	N0: 6
(4)	温度特性 Temperature Characteristics (T.C.)	N0: 7~9
(5)	引线形式 Lead style	N0: 10
(6)	引线间距 Lead spacing	N0: 11
(7)	标称容量 (额定容量) Rated capacitance	N0: 12~14
(8)	允许偏差 Capacitance Tolerance	N0: 15
(9)	包装形式 Packing style	N0: 16
(10)	环氧树脂包封料颜色 Epoxy color	N0: 17
(11)	内部电极 Internal electrode	N0: 18
(12)	尺寸代码 Size Code	N0: 19~20

### 5.1 产品类型 Product Type (N0: 1~4)

代码	产品类型
CT7-	交流 (安规) 系列电容器 Alternating current disk ceramic capacitor
CT81	中高压高介电常数系列电容器 High voltage high dielectric constant disk ceramic capacitor
CC81	中高压高压温度补偿系列电容器 High voltage temperature compensation capacitor

### 5.2 额定电压及代码 Rated Voltage and the code (N0: 5)

代码 code	N	M	P	Q	R	S	U	W	T	Z	A	X	Y	B	C
电压 Voltage	1KV DC	2KV DC	3KV DC	4KV DC	5KV DC	6KV DC	8KV DC	10KV DC	12KV DC	15KV DC	20KV DC	250V AC	400V AC	300V AC	500V AC

### 5.3 直径代码 Diameter Code (N0: 6)

代码 code	4	5	6	7	8	9	10	11
成品尺寸 Finished dimension	7.0max	8.0max	9.0max	10.0max	11.0max	12.0max	13.0max	14.0max
代码 code	12	13	14	15	附注说明 Notes			
成品尺寸 Finished dimension	15.0max	16.0max	17.0max	18.0max	供参考, 具体规格尺寸见《产品规格栏》 For reference, see product specification column for specific specifications			



# 圆片瓷介电容器 Ceramic Disc Capacitor

## 5.4 温度特性 T.C. Temperature Characteristics (NO: 7~9)

材质代码 Material Code		温度特性 Temperature Characteristics (温度范围 Temperature range)	容量允许偏差 Capacity tolerance	工作温度范围 Operating temperature range
Used code	EIA code			
NPO	C0H	-55°C ~ +125°C	0 ± 60 PPM/°C	-55°C ~ +125°C
N750	U2J	-25°C ~ +85°C	750 ± 120 PPM/°C	-25°C ~ +125°C
SL	S2L		+140 ~ -1000 PPM/°C	
DL	S3L		+500 ~ -3300 PPM/°C	
T3M	T3M		4700 ± 1200 PPM/°C	
Y5P (B/BN)	Y5P (B/BN)		± 10%	
Y5R	Y5R		± 15%	
Y5U	Y5U		+20 / -60%	
Y5V	Y5V		+22 / -82%	

## 5.5 引线形式 Lead style (NO: 10)

代码 code	脚型 Foot type	图示 Pictorial Representation	代码 code	脚型 Foot type	图示 Pictorial Representation
0	前后打翘 Vertical		6	内弯 Inside kink	
1	直脚 (长脚) Straight (Long legs)		7	直脚-改善型 Straight (Improved type)	
3	直脚 (短脚) Straight (Short feet)		9	单外弯 Outside kink	
4	直脚 (编带) Straight (Taping)				

## 5.6 引线间距 Lead spacing (NO: 11)

代码 code	B	D	E	F	G
脚距 (mm) Lead spacing (mm)	5.0 ± 0.5	7.5 ± 0.5	10.0 ± 0.5	12.5 ± 1.0	15.0 ± 1.0

## 5.7 标称容量 (额定容量) Rated capacitance (NO: 12~14)



# 圆片瓷介电容器 Ceramic Disc Capacitor

代码 Code	容量 capacitance	注：标称容量以 pF 为单位，用 3 位数字表示。前两位数字表示有效数字，第 3 位数字表示有效数字后的 0 的个数；R 表示小数点。 Note: The nominal capacity is expressed in pF with 3 digits. The first two digits represent significant figures, and the third digit represents the number of 0 after significant figures; R is the decimal point.
4R7	4.7pF	
330	33pF	
471	470pF	
103	1000pF	

## 5.8 允许偏差 Capacitance Tolerance (N0: 15)

代码 code	K	M	S	Z
容差 Tolerance	±10%	±20%	+50/-20%	+80%/-20%

## 5.9 包装形式 Packing style (N0: 16)

代码 code	S	T
包装形式 Packing style	散包装 Bulking	编带包装 Taping

## 5.10 环氧树脂包封料颜色 Epoxy color (N0: 17)

代码 code	E	F
环氧树脂 Epoxy	黄色 Yellow	蓝色 Blue

## 5.11 内部电极 Internal electrode (N0: 18)

代码 code	A	C	X	附注说明 Notes: 仅内部使用，不做对外承认。 For internal use only, without external recognition
电极 Electrode	银 Ag	铜 Cu	小型化铜 Cu	

## 5.12 尺寸代码 Size Code (N0: 19~20)

适用编带产品 (步距尺寸单位: mm) Taping products (step:mm)											
代码 code	尺寸 Dimensions	代码 code	尺寸 Dimensions	代码 code	尺寸 Dimensions	代码 code	尺寸 Dimensions				
01	12.7-盒装 (Boxed)	03	25.4-盒装 (Boxed)	05	12.7-卷装 (Roll Up)	07	25.4-卷装 (Roll Up)				
02	15.0-盒装 (Boxed)	04	30.0-盒装 (Boxed)	06	15.0-卷装 (Roll Up)	08	30.0-卷装 (Roll Up)				
适用散装产品 (引脚尺寸单位: mm)											
代码 code	尺寸 Dimensions	代码 code	尺寸 Dimensions	代码 code	尺寸 Dimensions	代码 code	尺寸 Dimensions	代码 code	尺寸 Dimensions	代码 code	尺寸 Dimensions
A0	2.0	B0	3.0	C0	4.0	D0	5.0	E0	6.0	F0	7.0
A1	2.1	B1	3.1	C1	4.1	D1	5.1	E1	6.1	F1	7.1
A2	2.2	B2	3.2	C2	4.2	D2	5.2	E2	6.2	F2	7.2
A3	2.3	B3	3.3	C3	4.3	D3	5.3	E3	6.3	F3	7.3
A4	2.4	B4	3.4	C4	4.4	D4	5.4	E4	6.4	F4	7.4
A5	2.5	B5	3.5	C5	4.5	D5	5.5	E5	6.5	F5	7.5
A6	2.6	B6	3.6	C6	4.6	D6	5.6	E6	6.6	F6	7.6
A7	2.7	B7	3.7	C7	4.7	D7	5.7	E7	6.7	F7	7.7
A8	2.8	B8	3.8	C8	4.8	D8	5.8	E8	6.8	F8	7.8
A9	2.9	B9	3.9	C9	4.9	D9	5.9	E9	6.9	F9	7.9
适用散装产品 (引脚尺寸单位: mm)											
代码 code	尺寸 Dimensions	代码 code	尺寸 Dimensions	代码 code	尺寸 Dimensions	代码 code	尺寸 Dimensions			代码 code	尺寸 Dimensions
G0	8.0	H0	9.0	I0	10.0	J0	11.0			T0	20.0
.	.	.	.	.	.	无 None	无 None			无 None	无 None
G9	8.9	H9	9.9	I9	10.9						

附注：剪脚品，对应代码表示引脚尺寸的中心值；长引脚品统一使用“T0”代表最小的尺寸为 20mm

Notes: Cut Pin products, the corresponding code represents the central value of pin size; long pin products uniform use "t 0" represents the minimum size of 20 mm





# 圆片瓷介电容器 Ceramic Disc Capacitor

## 6、编带尺寸 Taping

### 6.1 直脚编带 Straight taping

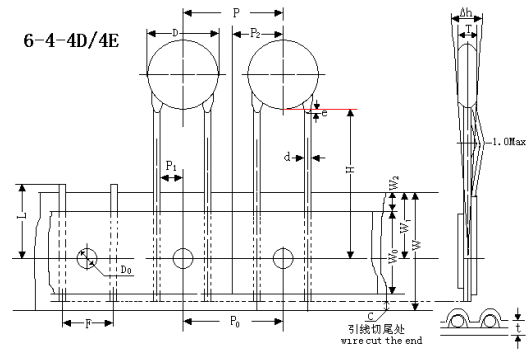
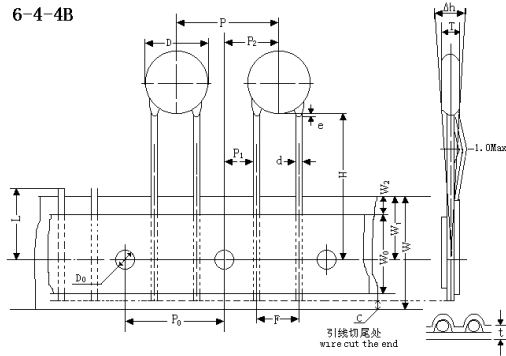

单位: mm

序号 No.	符号 Code	引线代码 lead code	引线代码 Lead code		引线代码 Lead code	
1	D	$\leq 10.0$	$\leq 10.0$	$\leq 13.0$	$\leq 13.0$	—
2	P	$12.7 \pm 2.0$	$12.7 \pm 2.0$	$15.0 \pm 2.0$	$15.0 \pm 2.0$	$25.4 \pm 2.0$
3	P <sub>0</sub>	$12.7 \pm 0.3$	$12.7 \pm 0.3$	$15.0 \pm 0.3$	$15.0 \pm 0.3$	$12.7 \pm 0.3$
4	P <sub>1</sub>	$3.85 \pm 0.7$	$2.6 \pm 0.7$	$3.75 \pm 0.7$	$2.5 \pm 0.7$	$7.7 \pm 0.7$
5	P <sub>2</sub>	$6.35 \pm 1.0$	$6.35 \pm 1.0$	$7.5 \pm 1.0$	$7.5 \pm 1.0$	$12.7 \pm 1.0$
6	F	$5.0 \pm 0.5$	$7.5 \pm 0.5$		$10.0 \pm 0.5$	
7	d	$0.50 \pm 0.08$	$0.50/0.60 \pm 0.08$		$0.60 \pm 0.08$	
8	e	2.0 Max 或弯折卡位内				
9	H	$20.0 \pm 2.0$	$20.0 \pm 2.0$		$20.0 \pm 2.0$	
10	Δh	2.0 Max	2.0 Max		2.0 Max	
11	T	4.0 Max	5.0 Max		6.0 Max	
12	D <sub>0</sub>	$4.0 \pm 0.2$	$4.0 \pm 0.2$		$4.0 \pm 0.2$	
13	W	$18.0 \pm 0.5$	$18.0 \pm 0.5$		$18.0 \pm 0.5$	
14	W <sub>0</sub>	7.5 Min	9.0 Min		9.0 Min	
15	W <sub>1</sub>	$9.0 \pm 0.5$	$9.0 \pm 0.5$		$9.0 \pm 0.5$	
16	W <sub>2</sub>	$1.5 \pm 1.5$	$1.5 \pm 1.5$		$1.5 \pm 1.5$	
17	L	11.0 Max	11.0 Max		11.0 Max	
18	C	0~5.0	0~5.0		0~5.0	
19	t	$0.7 \pm 0.2$	$0.7 \pm 0.2$		$0.7 \pm 0.2$	
20	h	4.0Max	4.0Max		4.0Max	



# 圆片瓷介电容器 Ceramic Disc Capacitor

## 6.2 内弯编带 Inside kink taping

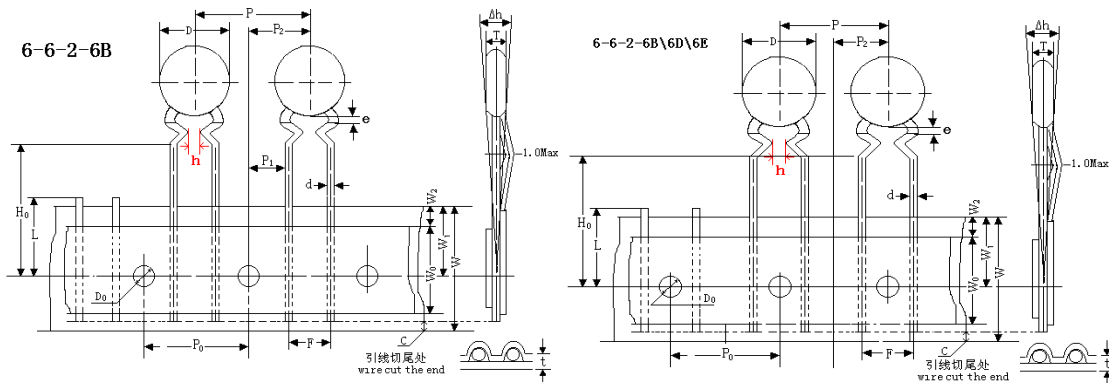

单位: mm

序号 No.	符号 Code	引线代码 lead code	引线代码 Lead code		引线代码 Lead code	
1	D	$\leq 10.0$	$\leq 10.0$	$\leq 13.0$	$\leq 13.0$	——
2	P	$12.7 \pm 2.0$	$12.7 \pm 2.0$	$15.0 \pm 2.0$	$15.0 \pm 2.0$	$25.4 \pm 2.0$
3	P <sub>0</sub>	$12.7 \pm 0.3$	$12.7 \pm 0.3$	$15.0 \pm 0.3$	$15.0 \pm 0.3$	$12.7 \pm 0.3$
4	P <sub>1</sub>	$3.85 \pm 0.7$	$2.6 \pm 0.7$	$3.75 \pm 0.7$	$2.5 \pm 0.7$	$7.7 \pm 0.7$
5	P <sub>2</sub>	$6.35 \pm 1.0$	$6.35 \pm 1.0$	$7.5 \pm 1.0$	$7.5 \pm 1.0$	$12.7 \pm 1.0$
6	F	$5.0 \pm 0.5$	$7.5 \pm 0.5$		$10.0 \pm 0.5$	
7	d	$0.50 \pm 0.08$	$0.50/0.60 \pm 0.08$		$0.60 \pm 0.08$	
8	e	2.0 Max 或弯折卡位内				
9	H	$18.0 \pm 2.0$	$18.0 \pm 2.0$		$18.0 \pm 2.0$	
10	$\Delta h$	2.0 Max	2.0 Max		2.0 Max	
11	T	4.0 Max	5.0 Max		6.0 Max	
12	D <sub>0</sub>	$4.0 \pm 0.2$	$4.0 \pm 0.2$		$4.0 \pm 0.2$	
13	W	$18.0 \pm 0.5$	$18.0 \pm 0.5$		$18.0 \pm 0.5$	
14	W <sub>0</sub>	7.5 Min	9.0 Min		9.0 Min	
15	W <sub>1</sub>	$9.0 \pm 0.5$	$9.0 \pm 0.5$		$9.0 \pm 0.5$	
16	W <sub>2</sub>	$1.5 \pm 1.5$	$1.5 \pm 1.5$		$1.5 \pm 1.5$	
17	L	11.0 Max	11.0 Max		11.0 Max	
18	C	0~5.0	0~5.0		0~5.0	
19	t	$0.7 \pm 0.2$	$0.7 \pm 0.2$		$0.7 \pm 0.2$	
20	h	4.0Max	4.0Max		4.0Max	



# 圆片瓷介电容器 Ceramic Disc Capacitor

## 6.3 单外弯编带 Single Outside kink tapping

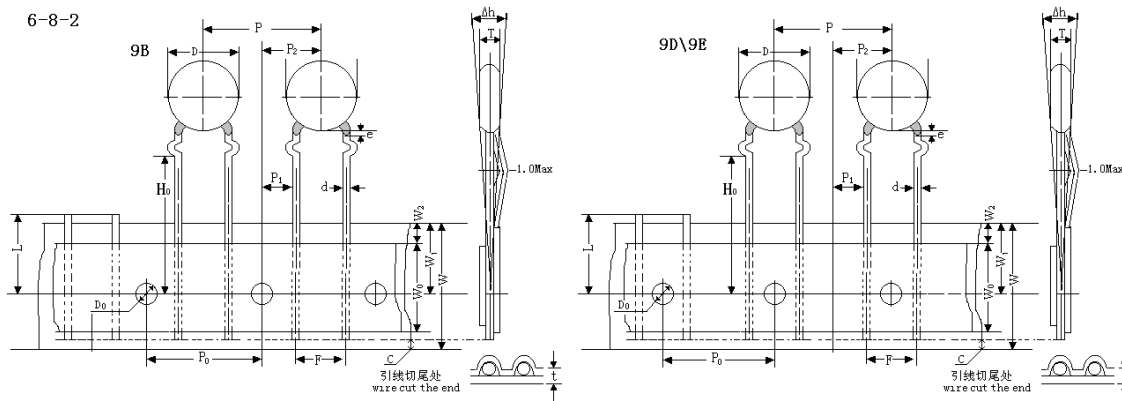

单位: mm

序号 No.	符号 Code	引线代码 lead code	引线代码 Lead code		引线代码 Lead code	
1	D	$\leq 10.0$	$\leq 10.0$	$\leq 13.0$	$\leq 13.0$	——
2	P	$12.7 \pm 2.0$	$12.7 \pm 2.0$	$15.0 \pm 2.0$	$15.0 \pm 2.0$	$25.4 \pm 2.0$
3	P <sub>0</sub>	$12.7 \pm 0.3$	$12.7 \pm 0.3$	$15.0 \pm 0.3$	$15.0 \pm 0.3$	$12.7 \pm 0.3$
4	P <sub>1</sub>	$3.85 \pm 0.7$	$2.6 \pm 0.7$	$3.75 \pm 0.7$	$2.5 \pm 0.7$	$7.7 \pm 0.7$
5	P <sub>2</sub>	$6.35 \pm 1.0$	$6.35 \pm 1.0$	$7.5 \pm 1.0$	$7.5 \pm 1.0$	$12.7 \pm 1.0$
6	F	$5.0 \pm 0.5$	$7.5 \pm 0.5$		$10.0 \pm 0.5$	
7	d	$0.50 \pm 0.08$	$0.50/0.60 \pm 0.08$		$0.60 \pm 0.08$	
8	e	2.0 Max 或弯折卡位内				
9	H	$18.0 \pm 2.0$	$18.0 \pm 2.0$		$18.0 \pm 2.0$	
10	$\Delta h$	2.0 Max	2.0 Max		2.0 Max	
11	T	4.0 Max	5.0 Max		6.0 Max	
12	D <sub>0</sub>	$4.0 \pm 0.2$	$4.0 \pm 0.2$		$4.0 \pm 0.2$	
13	W	$18.0 \pm 0.5$	$18.0 \pm 0.5$		$18.0 \pm 0.5$	
14	W <sub>0</sub>	7.5 Min	9.0 Min		9.0 Min	
15	W <sub>1</sub>	$9.0 \pm 0.5$	$9.0 \pm 0.5$		$9.0 \pm 0.5$	
16	W <sub>2</sub>	$1.5 \pm 1.5$	$1.5 \pm 1.5$		$1.5 \pm 1.5$	
17	L	11.0 Max	11.0 Max		11.0 Max	
18	C	0~5.0	0~5.0		0~5.0	
19	t	$0.7 \pm 0.2$	$0.7 \pm 0.2$		$0.7 \pm 0.2$	
20	h	4.0Max	4.0Max		4.0Max	



# 圆片瓷介电容器 Ceramic Disc Capacitor

## 6.4 前后翘编带 Vertical crimp lead taping

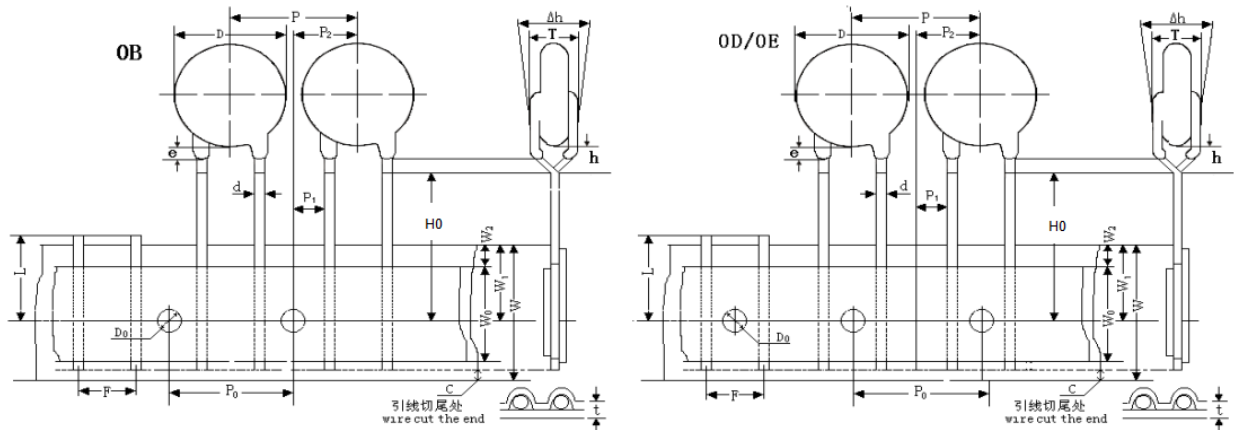

单位: mm

序号 No.	符号 Code	引线代码 lead code	引线代码 Lead code		引线代码 Lead code	
1	D	$\cong 10.0$	$\cong 10.0$	$\cong 13.0$	$\cong 13.0$	——
2	P	$12.7 \pm 2.0$	$12.7 \pm 2.0$	$15.0 \pm 2.0$	$15.0 \pm 2.0$	$25.4 \pm 2.0$
3	P <sub>0</sub>	$12.7 \pm 0.3$	$12.7 \pm 0.3$	$15.0 \pm 0.3$	$15.0 \pm 0.3$	$12.7 \pm 0.3$
4	P <sub>1</sub>	$3.85 \pm 0.7$	$2.6 \pm 0.7$	$3.75 \pm 0.7$	$2.5 \pm 0.7$	$7.7 \pm 0.7$
5	P <sub>2</sub>	$6.35 \pm 1.0$	$6.35 \pm 1.0$	$7.5 \pm 1.0$	$7.5 \pm 1.0$	$12.7 \pm 1.0$
6	F	$5.0 \pm 0.5$	$7.5 \pm 0.5$		$10.0 \pm 0.5$	
7	d	$0.50 \pm 0.08$	$0.50/0.60 \pm 0.08$		$0.60 \pm 0.08$	
8	e	2.0 Max 或弯折卡位内				
9	H <sub>0</sub>	$18.0 \pm 2.0$	$18.0 \pm 2.0$		$18.0 \pm 2.0$	
10	Δh	2.0 Max	2.0 Max		2.0 Max	
11	T	4.0 Max	5.0 Max		6.0 Max	
12	D <sub>0</sub>	$4.0 \pm 0.2$	$4.0 \pm 0.2$		$4.0 \pm 0.2$	
13	W	$18.0 \pm 0.5$	$18.0 \pm 0.5$		$18.0 \pm 0.5$	
14	W <sub>0</sub>	7.5 Min	9.0 Min		9.0 Min	
15	W <sub>1</sub>	$9.0 \pm 0.5$	$9.0 \pm 0.5$		$9.0 \pm 0.5$	
16	W <sub>2</sub>	$1.5 \pm 1.5$	$1.5 \pm 1.5$		$1.5 \pm 1.5$	
17	L	11.0 Max	11.0 Max		11.0 Max	
18	C	0~5.0	0~5.0		0~5.0	
19	t	$0.7 \pm 0.2$	$0.7 \pm 0.2$		$0.7 \pm 0.2$	
20	h	4.0Max	4.0Max		4.0Max	



# 圆片瓷介电容器 Ceramic Disc Capacitor

## 7、产品标示 product marking

### 7.1 高频产品标示

序号 No.	标示项目 Marking Items	代码 code	图例 legend
1	风华商标 FH logo	FH	
2	标称容量 Rated capacitance	47(47pF)	
3	容量偏差 Capacitance tolerance	K( $\pm 10\%$ )	
4	额定电压 Rated voltage	2KVDC	

### 7.2 低频产品标示

序号 No.	标示项目 Marking Items	代码 code	图例 legend
1	风华商标 FH logo	FH	
2	温度特性(T.C.)	F(Y5V)	
3	标称容量 Rated capacitance	102(1000pF)	
4	容量偏差 Capacitance tolerance	K( $\pm 10\%$ )	
5	额定电压 Rated voltage	2KVDC	

### 7.3 安规产品标示

序号 No.	标示项目 Marking Items	代码 code	图例 legend
--------	--------------------	---------	-----------



# 圆片瓷介电容器 Ceramic Disc Capacitor

1	风华商标 FH logo	FH	
2	产品类型 Product type	CT7-Y1 交流（安规）系列电容器	
3	安规认证 Safety certification		
4	温度特性(T.C.)	F(Y5V)	
5	标称容量 Rated capacitance	472(4700pF)	
6	容量偏差 Capacitance tolerance	M(±20%)	
7	额定电压 Rated voltage	250VAC	

## 8、产品额定值 Product rated parameters

（温度特性、额定电压、标称容量、容量偏差、引线间距、本体直径、本体厚度） T.C.、Rated voltage、Rated capacitance、Capacitance Tolerance、Lead spacing、BodyDiameter、BodyThickness

产品类型 Product Type	温度特性 T.C.	额定电压 Rated voltage(V)	标称容量 Rated capacitance (pF)	允许偏差 Capacitance Tolerance (%)	芯片直径 Chip diameter (mm)	成品直径 Finished diameter(mm)	成品厚度 Finished thickness(mm)
CC81	N750	1KV(N)	10~30	±10%(K)	3.5~5.5	6.5 Max	3.5Max
	SL		33~56		3.5~5.5		
			68~101		5.0~6.5	7.5Max	
	SL	2KV(M)	22~56	±10%(K)	3.5~5.5	6.5 Max	4.0Max
			68~101		5.0~6.5	7.5 Max	
	N750	3KV(P)	22	±10%(K)	3.5~5.5	6.5 Max	5.0Max
	SL		27~47		3.5~5.5		
			68		5.5~6.5	7.5 Max	
82~101			7.0~8.5		9.5 Max		
CT81	Y5P	1KV(N)	151~681	±10%(K)	3.5~5.5	6.5 Max	3.5Max
			821~102		5.0~6.5	7.5Max	
			152~222		6.0~8.4	9.5Max	
			182~222		6.5~8.5	9.5Max	
			272~392		7.5~9.5	10.5Max	



# 圆片瓷介电容器 Ceramic Disc Capacitor

		2KV(M)	472	±10%(K)	11.3~12.5	14.0Max	4.0Max		
			101~391		3.5~5.5	6.5 Max	4.0Max		
			471~681		5.0~6.5	7.5Max			
			102~132		6.0~7.5	8.5Max			
			152~172		7.5~8.5	9.5Max			
			182~222		8.5~10.5	11.5Max			
			352~272		9.5~11.5	13.0Max		4.5Max	
		332~392	11.5~12.5	14.0Max					
		3KV(P)	101~471	±10%(K)	3.5~5.5	7.5 Max	5.0Max		
			471~821		5.5~7.5	9.5Max			
			901~172		7.0~9.5	11.5Max			
			182~302		9.5~12.5	14.5Max			
		附注 Notes	若需 4KV~15KV 的, 请提供贵司的参数要求, 我会参照要求提供对应的尺寸, 谢谢! If need 4KV ~ 15KV, please provide your company's parameter request, we will provide the corresponding size according to the request, thanks!						

产品类型 Product Type	温度 特性 T.C.	额定电压 Rated voltage(V)	标称容量 Rated capacitance(pF)	允许偏差 Capacitance Tolerance(%)	芯片直径 Chip diameter (mm)	成品直径 Finished diameter(mm)	成品厚度 Finished thickness(mm)
CT81	Y5U	1KV(N)	102~362	±20%(M) +80/-20%(Z)	3.5~5.5	6.5 Max	3.5Max
			392~562		5.6~7.4	8.5Max	
			692~872		7.5~8.4	9.5Max	
			103		8.5~9.4	10.5Max	
		2KV(M)	821~202	±20%(M) +80/-20%(Z)	3.5~5.5	6.5 Max	4.0Max
			202~272		5.5~6.4	7.5Max	
			332~392		6.5~7.4	8.5Max	
			472、502		7.5~8.4	9.5Max	
			602~682		8.5~9.4	10.5Max	
			702~922		9.5~11.5	13.5Max	
			103		1.5~12.5	14.5Max	
		3KV(P)	621~142	±20%(M) +80/-20%(Z)	3.5~5.5	7.0 Max	5.0Max
			142~182		5.5~6.4	8.0Max	
			202~272		6.5~7.4	9.0Max	
			302~372		7.5~8.4	10.0Max	
			382~472		8.5~9.4	12.0Max	
			502~822		9.5~12.5	14.5Max	
CT81	Y5V	1KV(N)	102~222	±20%(M)	3.5~5.5	6.5 Max	3.5Max
			222~332		5.5~6.4	7.5Max	



# 圆片瓷介电容器 Ceramic Disc Capacitor

			472~682	+80/-20%(Z)	6.5~7.4	8.5Max			
			682~822		7.5~8.4	9.5Max			
			822~103		8.5~9.4	10.5Max			
		2KV(M)	±20%(M)	+80/-20%(Z)	182~332	3.5~5.4		6.5 Max	4.0Max
					352~472	5.5~6.4		7.5Max	
					562~702	6.5~7.4		8.5Max	
					392~472	7.5~8.4		9.5Max	
					792~103	8.5~9.4		11.0Max	
		3KV(P)	±20%(M)	+80/-20%(Z)	102~252	3.5~5.4		8.5Max	5.0Max
					262~332	5.5~6.4		9.5Max	
					392~472	6.5~7.4		10.5Max	
					562~652	7.5~8.4		11.5Max	
					682~852	8.5~9.4		12.5Max	
					103	11.5~12.4		14.5Max	

附注  
Notes

若需 4KV~15KV 的, 请提供贵司的参数要求, 我会参照要求提供对应的尺寸, 谢谢!  
If need 4KV ~ 15KV, please provide your company's parameter request, we will provide the corresponding size according to the request, thanks!

产品类型 Product Type	温度特性 T.C.	额定电压 Rated voltage(V)	标称容量 Rated capacitance(pF)	允许偏差 Capacitance Tolerance(%)	芯片直径 Chip diameter (mm)	成品直径 Finished diameter(mm)	成品厚度 Finished thickness(mm)
CT7	Y5P	X: 250VAC B: 300VAC	101~481	±10%(K)	3.5~5.4	8.0 Max	5.0Max
			491~711		5.5~6.4	9.0 Max	
			721~991		6.5~7.4	10.0 Max	
			102~122		7.5~8.4	11.0 Max	
			132~152		8.5~9.4	12.0 Max	
	Y5U	X: 250VAC B: 300VAC	681~132	±20%(M) +80/-20%(Z)	3.5~5.4	8.0 Max	5.0Max
			142~192		5.5~6.4	9.0 Max	
			202~262		6.5~7.4	10.0 Max	
			272~322		7.5~8.4	11.0 Max	
			332~432		8.5~9.4	12.0 Max	
			472~682		10.0~12.4	15.0 Max	
	Y5V	X: 250VAC B: 300VAC	102~232	±20%(M) +80/-20%(Z)	3.5~5.4	8.0 Max	5.0Max
			242~332		5.5~6.4	9.0 Max	
			342~472		6.5~7.4	10.0 Max	
			482~572		7.5~8.4	11.0 Max	
			582~742		8.5~9.4	12.0 Max	
			752~103		10.0~12.0	15.0 Max	

产品类型 Product Type	温度特性 T.C.	额定电压 Rated voltage(V)	标称容量 Rated capacitance(pF)	允许偏差 Capacitance Tolerance(%)	芯片直径 Chip diameter (mm)	成品直径 Finished diameter(mm)	成品厚度 Finished thickness(mm)
CT7	Y5P	Y: 400VAC	101~351	±10%(K)	3.5~5.4	8.0 Max	6.0Max
		C: 500VAC	361~471		5.5~6.4	9.0 Max	





# 圆片瓷介电容器 Ceramic Disc Capacitor

			481~651		6.5~7.4	10.0 Max	6.0Max
			661~841		7.5~8.4	11.0 Max	
			851~102		8.5~9.4	12.0 Max	
	Y5U	Y: 400VAC C: 500VAC	±20%(M) +80/-20%(Z)	471~102	3.5~5.4	10.0 Max	
				102~132	5.5~6.4	9.0 Max	
				142~182	6.5~7.4	10.0 Max	
				192~222	7.5~8.4	11.0 Max	
				232~292	8.5~9.4	12.0 Max	
				302~332	9.5~10.4	13.0 Max	
	472	11.5~12.4	15.0 Max				
	Y5V	Y: 400VAC C: 500VAC	±20%(M) +80/-20%(Z)	821~172	3.5~5.4	8.0 Max	
				172~222	5.5~6.4	9.0 Max	
				222~312	6.5~7.4	10.0 Max	
				322~392	7.5~8.4	11.0 Max	
				402~472	8.5~9.4	12.0 Max	

## 9、可靠性测试方法 Specification and test method

项 目 Item	性 能 Performances			试验方法及条件 Test method			
1、 外观构造及尺寸 appearance and dimension	外观无异常 构造及尺寸依图示规定 No damage in appearance and dimension accord with fixed			目视检验尺寸以游标卡尺测量 Venire caliper			
2、 静电容量 Capacitance	规定之容许误差以内 Within specified tolerance			测试频率和测试电压 Measuring frequency & Measuring voltage:			
3、 损耗角正切值 Loss angle Tangent value Tg δ (散逸因数 Dissipation Factor)	CC81	NPO N750 SL	≤0.0015	1、NP0、N750、SL: 1±0.1MHz, 1.0 Vrms 2、Y5R、Y5P、Y5U、Y5V: 1±0.1KHz, 1.0Vrms 测试温度 Measuring temperature: 25±2°C			
		CT81 CT7	Y5R				≤0.005
	Y5P		BN				≤0.005
			B				≤0.025
	Y5U	≤0.030					
Y5V	≤0.035						
4、 绝缘电阻 (端子间.) Insulation resistance (I.R)	CC81	≥ 10000M Ω		测试电压 Test voltage	500VDC	施加时间 Application time: 60±5S	
	CT81	≥ 10000 M Ω			500VDC		



# 圆片瓷介电容器 Ceramic Disc Capacitor

Between lead wire		CT7	$\geq 10000M\Omega$		500VDC	
5、 耐电压 Voltage- Proof	端子间 Between terminati ons	无不良 No bed result		测试电压 Test voltage	CC81 CT81	1KV $\leq$ UR $\leq$ 5KV : 1.5UR+500V $\geq$ 6KV: UR+500V
					CT7	10 UR
				施加时间 Applicatio n time	逐批检验 Lot by lot inspection: 3S 鉴定和周期检验 Identification and periodic Inspection: 60S	
				充放电电流 Charge/discharge current:	$\leq 50mA$	
6、 温度特性 Temperatur e Characteris tics	端子与 外装间 Between terminatio ns and enclosure	无不良 No bed result		金属小球法 Small metallic ball method is used		
				测试电 压 Test voltage	CC81 CT81	1KV $\leq$ UR $\leq$ 5KV : 1.5UR+500V
					CT7	10UR
				施加时间 Application time: 充放电电流 Charging/discharging current:	60S $\leq 50mA$	
	未施加 电压 Without voltage applicatio n	在允许规格范围内 <Within specified tolerance>		依次按以下温度循环阶段测定 According to the following in temperature cycle phase measurement		
				阶段 Step	温度(°C)Temperature	
				1	20°C	
				2	NPO	-55°C
					Y5P\Y5R\Y5U\Y5V\ N750\SL	-25°C
				3	20°C	
				4	NPO\N750\SL	+125 °C
					Y5P\Y5R\Y5U\Y5V	+85°C
				5	20°C	
				TC: 为相对于 20 $\pm$ 2°C时的容量变化率 TC: Volume change rate relative to 20 $\pm$ 2°C		



# 圆片瓷介电容器 Ceramic Disc Capacitor

	施加额定电压 Rated voltage applied	NPO	在±3%或±0.03PF以内,取较大者为准 Within ±3% or ±0.03PF, based upon whichever is higher	依次按以下温度循环阶段测定 According to the following in temperature cycle phase measurement			
		N750		阶段 Step	温度(°C)Temperature		
		SL			1	20°C	
		B/R	+10/-15%	2	NPO		-55°C
		E(Y5U)	+20/-60%		Y5P\Y5R\Y5U\Y5V\N750\SL		-25°C
		F(Y5V)	+30/-80%	3	20°C		
				4	NPO\N750\SL		+125°C
		Y5P\Y5R\Y5U\Y5V			+85°C		
		5	20°C				
				TC: 为相对于 20±2°C时的容量变化率 TC: Volume change rate relative to 20±2°C			
7、端子强度 Robustness Of Termination	抗拉强度 Tensile strength	引线不断裂, 电容器不破损 No abnormalities such as breaking or loosening of termination	电容器轴方向加重量 <Apply the tension in the direction of emergence of termination>				
			线径(mm) Wire diameter	拉力(Kg) Tensile force	持续时间(s) time of duration		
			0.31~0.49	0.5kgf	10±1		
	0.50~0.80	1.0kgf					
	弯曲强度 Bending strength	引线不断裂, 电容器不破损 No abnormalities such as breaking or loosening of termination	导线垂直方向加重向下, 本体向左90°弯曲试验2次。 Apply the tension in the direction of vertical and bend it for 90°, after reset, bend it for 90° in reverse direction twice				
			线径(mm) Wire diameter	拉力(Kg) Tensile force			
0.31~0.49			0.25				
		0.50~0.80	0.5				
8、耐振性 (振动) Vibration-Resistance	外观 Appearance	无显著异常 并且容易判断出来 No remarkable abnormality and marking shall be easily legible	频率依次为: 10Hz→55Hz→10Hz 振幅: 0.75mm, 持续时间: 60S。 Frequency is as follows: 10Hz→55Hz→10Hz Amplitude: 0.75 mm length of time: 60 S				



# 圆片瓷介电容器 Ceramic Disc Capacitor

(vibrate)	静电容量 Capacitance	规格之容许差以内 Within specified tolerance		在 X、Y、Z 三个互相垂直的方向各振动 2 小时，产品无破损、开裂等不良现象。 In the X, Y, Z three mutually perpendicular direction the vibration 2 hours, the products without damage, cracking and other unhealthy phenomenon.			
	损耗角正切值 Loss angle tangent value $\text{tg}\delta$	满足项目 5 的要求 To satisfy Number 5					
9、 可焊性 Solder ability	引线表面均匀沾锡，上锡面积不小于总面积的 95% Lead uniformly on the surface of tin, tin area of not less than 95% of the total area.		焊锡温度 Soldering Temperature	245±5°C			
			浸入时间 Dipping Time	2.0±0.5S			
			上锡面积 Tin area	≥95%			
			浸入深度:距离电容本体 2.0±0.5mm Immersion depth: Distance capacitance body 2.0±0.5mm				
10、 耐焊接热 Welding heat resistant ability	外观 Appearance	无显著异常并且容易判断出来 No remarkable abnormality and marking shall be easily legible		预处理：在 125±2°C 温度下放置 1 小时，在常温下恢复 24±2 小时后测试。 Pretreatment: Capacitor shall be stored at 125±2°C for 1 hour, than placed at room condition for 24±2°C hour before test.			
	静电容量变化率 Relative capacitance change	NPO	在 ±2.5% 或 ±0.25PF 以内,取较大者为准 Within ±2.5% or ±0.25PF, based upon whichever is higher		焊接温度 Soldering Temperature	350 ± 10°C	260 ± 5°C
		N750			焊接时间 Dipping Time	3.5 ± 0.5sec	10 ± 1 sec
		SL				浸入深度：引线部分有 1.5~2.0mm 在锡面以上。 Immersion depth: Lead part 1.5~2.0mm in the solder side above.	
		B/R	±10%				
		E(Y5U)	±15%				
		F(Y5V)	±20%				

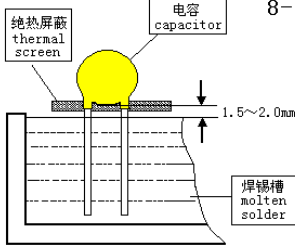

# 圆片瓷介电容器 Ceramic Disc Capacitor

	<p>耐电压 Voltage -proof (端子 间) (between n termina tions)</p>	<p>参照项目 5 内容 With reference to the project 5 content</p>	 <p>8-1</p> <p>后处理：电容器应当在室温下放置 1~2 小时。</p> <p>Post processing: Capacitor shall be stored for 1~2h at room condition, before test.</p>
<p>11、 温度循环 Temperature Cycling</p>		<p>外观无可见损伤(10 倍放大镜); 电容量: <math>\Delta C/C \leq 15\%</math> (2 类电容)或 <math>\Delta C/C \leq +/-2.5\%</math> or <math>+/-0.25pF</math> (取较大者, 1 类电容 ); 损耗因数: <math>\leq</math> 初始规格上限 (品质因数: <math>\geq</math> 初始规格下限); 绝缘电阻: <math>\geq</math> 初始规格下限 No visible damage (10X magnifier) <math>\Delta C/C \leq 15\%</math> (for Class II ) or <math>\Delta C/C \leq +/-2.5\%</math> or <math>+/-0.25pF</math> (Whichever is larger, for Class I ) DF <math>\leq</math> initial limit (or Q <math>\geq</math> initial limit) IR: <math>\geq</math> initial limit</p>	<p>TL= 下限类别温度, TU= 上限类别温度; 在 TL 或 TU 的放置时间: 30 分钟; TL 与 TU 间转换时间: 1 分钟之内; 循环次数: 100 次; TL = Lower category temperature TU = Upper category temperature. Duration of the exposure@ TL or TU: 30 min. Transition time between TL and TU: within 1 min; Number of cycles: 100 cycles;</p>
<p>12. 高湿负荷 Humidity Loading (Biased Humidity)</p>		<p>外观无可见损伤(10 倍放大镜); 电容量: <math>\Delta C/C \leq 15\%</math> (2 类电容)或 <math>\Delta C/C \leq +/-2.5\%</math> or <math>+/-0.25pF</math> (取较大者, 1 类电容 ); 损耗因数: <math>\leq 5</math> 倍初始规格上限 (品质因数: <math>\geq 0.2</math> 倍初始规格下限); 绝缘电阻: <math>\geq 0.1</math> 倍初始规格下限 No visible damage (10X magnifier) <math>\Delta C/C \leq 15\%</math> (for Class II ) or <math>\Delta C/C \leq +/-2.5\%</math> or <math>+/-0.25pF</math> (Whichever is larger, for Class I ) DF <math>\leq 5X</math> initial limit (or Q <math>\geq 0.2X</math> initial limit) IR: <math>\geq 0.1X</math> initial limit</p>	<p>温度: 85°C; 湿度: 85%RH; 电压: 额定电压; 时间: 500 小时 Temperature: 85°C Humidity: 85%RH Voltage: Rated voltage Time: 500 hour</p>



# 圆片瓷介电容器 Ceramic Disc Capacitor

<p>13. 工作寿命 (耐久性) working life (Durability)</p>	<p>外观无可见损伤(10倍放大镜); 电容量: <math>\Delta C/C \leq 15\%</math> (2类电容)或 <math>\Delta C/C \leq \pm 2.5\%</math> or <math>\pm 0.25\text{pF}</math> (取较大者, 1类电容); 损耗因数: <math>\leq 5</math> 倍初始规格上限 (品质因数: <math>\geq 0.2</math> 倍初始规格下限); 绝缘电阻: <math>\geq 0.1</math> 倍初始规格下限 No visible damage (10X magnifier) <math>\Delta C/C \leq 15\%</math> (for Class II) or <math>\Delta C/C \leq \pm 2.5\%</math> or <math>\pm 0.25\text{pF}</math> (Whichever is larger, for Class I) <math>DF \leq 5X</math> initial limit (or <math>Q \geq 0.2X</math> initial limit) IR: <math>\geq 0.1X</math> initial limit</p>	<p>参考试验条件: 对于普通陶瓷电容器, 上限类别温度, 施加 150% 额定电压 1000hrs; 对于 Y 电容, 试验电压应为 170%UR (或 URDC); 备注: 本试验在脉冲电压试验完成后的一周内进行。 Reference condition: For common type ceramic capacitors, Upper limit category Temperature (TU), 150% rated voltage, 1000hrs; For Y capacitors, the test voltage shall be 170% UR (or URDC); Note: This test shall be conducted within one week after the completion of the pulse voltage test.</p>
<p>14. 脉冲电压 (Y 电容) Impulse Voltage (For x and y capacitors)</p>	<p>外观无可见损伤(10倍放大镜); 电容量变化: 不超过 <math>\pm 10\%</math> 损耗因数增加: <math>\leq 0.005</math>; 绝缘电阻: <math>\geq 0.5X</math> 初始规格下限 No visible damage (10X magnifier) <math>\Delta C/C</math>: Within <math>\pm 10\%</math> DF increase: <math>\leq 0.005</math> IR: <math>\geq 0.5 X</math> initial limit</p>	<p>参考波形: 1.2/50us; 峰值电压: 5KV(Y2)或 8KV(Y1); 24 次浪涌中有 3 次以上, 未发生自愈性击穿或闪火的情况为通过。 Reference waveform: 1.2/50us Peak voltage: 5KV (Y2) or 8KV (Y1). If all 24 impulses have been applied to the capacitor and 3 or more of them are of a waveform indicating that no self-healing breakdowns or flashovers have occurred, then the capacitor shall be counted as conforming.</p>
<p>15. 冷热冲击试验 Thermal Shock Test</p>	<p>外观无可见损伤(10倍放大镜); 电容量: <math>\Delta C/C \leq 15\%</math> (2类电容)或 <math>\Delta C/C \leq \pm 2.5\%</math> or <math>\pm 0.25\text{pF}</math> (取较大者, 1类电容); 损耗因数: <math>\leq</math> 初始规格上限 (品质因数: <math>\geq</math> 初始规格下限); 绝缘电阻: <math>\geq</math> 初始规格下限 No visible damage (10X magnifier) <math>\Delta C/C \leq 15\%</math> (for Class II) or <math>\Delta C/C \leq \pm 2.5\%</math> or <math>\pm 0.25\text{pF}</math> (Whichever is larger, for Class I) <math>DF \leq</math> initial limit (or <math>Q \geq</math> initial limit) IR: <math>\geq</math> initial limit</p>	<p>TL=下限类别温度, TU=上限类别温度; 在 TL 或 TU 的放置时间: 15 分钟; TL 与 TU 间转换时间: 20s 之内; 循环次数: 50 次; 试验前放置 <math>150 \pm 0/-10^\circ \text{C}</math> 1h, 然后室温下 <math>24 \pm 2</math> hrs; 试验后室温下 <math>24 \pm 2</math> hrs 再测试 TL=lower limit category temperature, TU=upper limit category temperature; Storage time in TL or TU: 15 minutes; Conversion time between TL and TU: within 20 seconds; Number of cycles: 50; Place at <math>150 \pm 0/-10^\circ \text{C}</math> for 1 hour before the experiment, and then at room temperature for <math>24 \pm 2</math> hours; Retest at room temperature for <math>24 \pm 2</math> hours after testing</p>



## 10、产品特性曲线图 product characteristics

### 10.1 I类电容器温度特性曲线 (CC81)

TC Chart for Class 1 capacitor

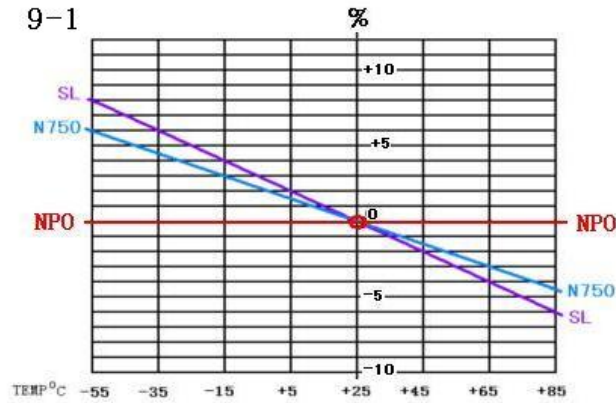

### 10.2 II类电容器温度特性曲线(CT81\CT7)

TC Chart for Class II capacitor

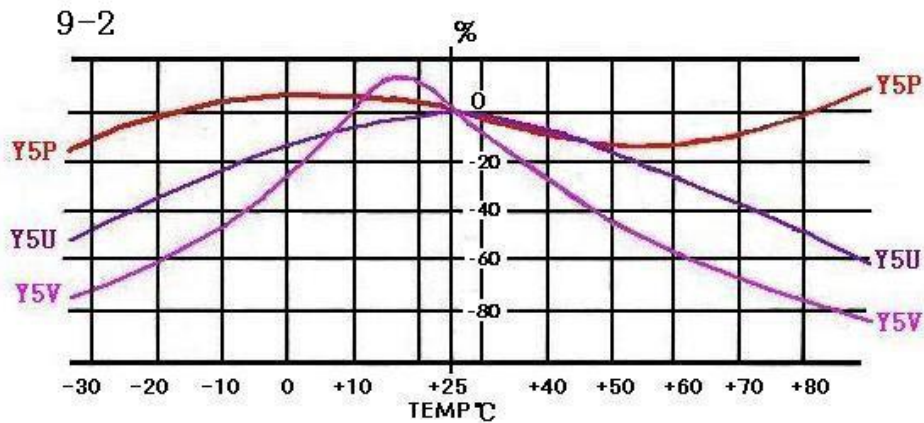

## 11、包装尺寸及数量 packing size and quantity

项目 Item	包装箱尺寸对应表 Packing size corresponding to the table	
	外箱 out box	内箱 inside box
散装 bulk	46×34.5×28 (cm)	33×22×12.5 (cm)
	46×31.5×23.5 (cm)	30×21.5×10.5 (cm)
	44.5×25.5×22 (cm)	24×21.5×9.5 (cm)
	32.5×27×23.5 (cm)	24×21.5×9.5 (cm)
编带 taping	52.5×28×36 (cm)	34.5×26.5×4.8 (cm)
	52.5×28×34.5 (cm)	33.0×26.5×4.8 (cm)



# 圆片瓷介电容器 Ceramic Disc Capacitor

产品类型 Product Type	额定电压 Voltage	散装 Bulk (pcs)					
		间距 Lead spacing F=5.0 (mm)		间距 Lead spacing F=7.5 (mm)		间距 Lead spacing F=10/12.5 (mm)	
直径 Diameter	---	$\Phi \leq 9\text{mm}$	$10\text{mm} \leq \Phi$	$\Phi \leq 9\text{mm}$	$10\text{mm} \leq \Phi$	$\Phi \leq 9\text{mm}$	$10\text{mm} \leq \Phi$
CT7	Y1/Y2	---		0.5Kpcs		0.5Kpcs	
CT81	1~6KVDC	1.0Kpcs	0.5Kpcs	1.0Kpcs	0.5Kpcs	1.0Kpcs	0.5Kpcs
CC81	8~20KVDC	---		---		0.5Kpcs	

产品类型 Product Type	额定电压 Voltage	编带 Taping (Kpcs)			
		间距 Lead spacing F=5.0 (mm)		间距 Lead spacing F=7.5 (mm)	
CT7	Y1/Y2	---		1.0Kpcs	
CT81	1~2KVDC	2.0Kpcs		1.0Kpcs	
CC81	3~6KVDC	---		1.0Kpcs	
	8~20KVDC	---		0.5Kpcs	

## 12、产品的储存 product 's storage

1、产品储存场地要整洁、干燥、通风、无漏水、无污染。

Product storage site to clean, dry and ventilated, no leakage, no pollution.

2、产品长时间储存时不易直接放在地面，要放在托架上进行防潮。

When storing the product for a long time, it is not easy to place it directly on the ground and should be placed on a bracket for moisture-proof purposes

3、注意按包装箱上的堆放高度对产品进行堆放。

Note based on the stacking height of packing products to pile up.

4、储存环境温度：-25℃~+40℃；储存期限：2年（附注：由于瓷介电容器具有老化特性，因此建议在使用前请检测确认容量参数，若检测发现容量偏低，则需对整批次产品进行返烘作业处理，处理后可以使用）。

Storage temperature: -25℃ ~ + 40℃; Storage life: 2 years (note: due to the aging characteristics of ceramic capacitors, it is recommended to check and confirm the capacity parameters before use. If the capacity is found to be low, the whole batch of products should be re baked for normal use).

## 13、注意事项 (Notes) :

1. 工作电压 Operating voltage:

在交流电路或纹波电流电路中使用直流额定电压电容器时,请务必确保外加电压的  $V_{p-p}$  值或包含直流偏置电压的  $V_{o-p}$  值保持在额定电压范围内。若向电路施加电压,开始或停止时可能会因谐振或切换产生暂时的不规则电压,请务必使用额定电压范围大于此不规则电压的电容器。

Be sure to maintain the  $V_{p-p}$  value of the applied voltage or the  $V_{o-p}$  which contains DC bias within the rated voltage range. When the voltage is started to apply to the circuit or it is stopped applying, the irregular voltage may be generated for a transit period because of resonance or switching. Be sure to use a capacitor





# 圆片瓷介电容器 Ceramic Disc Capacitor

within rated voltage containing this irregular voltage.

直流电压 DC voltage	直流+交流电压 DC+AC voltage	交流电压 AC voltage	冲击电压 (1) Pulse voltage(1)	冲击电压 (2) Pulse voltage(2)

## 2. 工作温度和自身发热 Operating temperature and self-generated heat:

电容器的表面温度应保持在额定工作温度范围的上限以下，务必考虑到电容器自身发出的热量。电容器在高频电流、冲击电流等中使用可能会因介电损耗自身发热，所施加之正弦波电压的频率应低于 300kHz。外加电压应使自身发热等负荷在 25℃ 周围温度条件下不超过 20℃ 范围，测量时应使用  $\phi 0.1\text{mm}$  小热容量的 (K) 的热电偶，而且电容器不应受到其它组件的散热或周围温度波动影响。过热可能会导致电容器特性及可靠性下降（切勿在冷却风扇运转时进行测量，否则无法确保测量数据的精确性）。

Keep the surface temperature of a capacitor below the upper limit of its rated operating temperature range. Be sure to take into account the heat generated by the capacitor itself. When the capacitor is used in a high-frequency current, pulse current or the like, it may have the self-generated heat due to dielectric loss. Applied voltage should be the load such as self-generated heat is within 20℃ on the condition of atmosphere temperature 25℃. When measuring, use a thermocouple of small thermal capacity-K of  $\phi 0.1\text{mm}$  and be in the condition where capacitor is not affected by radiant heat of other components and wind of surroundings. Excessive heat may lead to deterioration of the capacitor's characteristics and reliability. (Do not measure when the cooling fan is running, otherwise unable to ensure the accuracy of the measurement data.)

## 3. 耐电压的测试条件 Test condition for withstanding voltage:

### 3.1 测试设备 Test equipment:

交流耐电压的测试设备应具有能够产生类似于 50/60Hz 正弦波的功能，如果施加变形的正弦波或超过规定电压值的超载电压，则可能会导致故障。

Test equipment for AC withstanding voltage shall be used with the performance of the wave similar to 50/60 Hz sine waves. If the distorted sine wave or over load exceeding the specified voltage value is applied, the defective may be caused.

### 3.2 电压外加方法 Voltage applied method:

施加耐电压时，电容器的引线或端子应与耐电压测试设备的输出端连接牢固，然后再将电压从近零增加到测试电压。如果测试电压不从近零逐渐提高而是直接施加在电容器上，则施加时应包含过零点。测试结束时，测试电压应降到近零，然后再将电容器引线或端子从耐电压测试设备的输出端取



# 圆片瓷介电容器 Ceramic Disc Capacitor

下。

如果测试电压不从近零逐渐提高而是直接施加在 电容器上, 则可能会出现浪涌电压, 从而导致故障.

\*过零点是指电压正弦通过 0V 的位置。 参见右图:

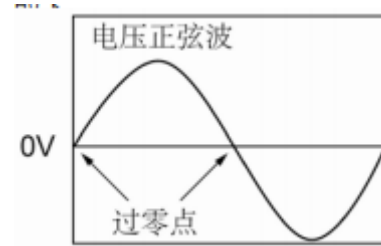

When the withstanding voltage is applied, capacitor's lead or terminal shall be firmly connected to the output of the withstanding voltage test equipment, and then the voltage shall be raised from near zero to the test voltage. If the test voltage without the raise from near zero voltage would be applied directly to capacitor, test voltage should be applied with the \*zero cross. At the end of the test time, the test voltage shall be reduced to near zero, and then capacitor's lead or terminal shall be taken off the output of the withstanding voltage test equipment. If the test voltage without the raise from near zero voltage would be applied directly to capacitor, the surge voltage may arise, and therefore, the defective may be caused. ZERO CROSS is the point where voltage sine wave pass 0V.- See the right figure.

#### 4. 失效安全性 Fail-Safe:

如果电容器破损, 会导致短路电路故障. 务必在本产品上适当提供例如保险丝等自动防故障功能, 以免导致电击、火灾、或冒烟等。

When capacitor would be broken, failure may result in a short circuit. Be sure to provide an appropriate fail-safe function like a fuse on your product if failure would follow an electric shock, fire or fume.

#### 5. 焊接、安装与使用 Soldering 、mounting and use:

##### 5.1 振荡与冲击 Vibration and impact

使用时请勿使电容器或引线受到过度冲击或振荡。

When using do not make the capacitor or lead by excessive impact or vibration.

##### 5.2 焊接 Soldering

将该产品焊接在 PCB/PWB 上时, 不应超出电容器的耐焊接热规格, 本产品过热会使内部接点锡焊料熔化, 导致温度骤变, 从而造成陶瓷组件产生裂纹。当使用烙铁焊接电容器时, 应遵循以下条件: 烙铁头温度: 最高 400°C; 烙铁功率: 最大 50W; 焊接时间: 最多 3.5 秒

When soldering this product to a PCB/PWB, do not exceed the solder heat resistance specification of the capacitor. Subjecting this product to excessive heating could melt the internal junction solder, Lead to temperature shock , Resulting in the ceramic element to produce crack. When soldering capacitor with a soldering iron, it should be performed in following conditions: Temperature of iron-tip: 400 degrees C. max. Soldering iron wattage: 50W max.

#### 6. 清洗 (超声波清洗) Cleaning (ultrasonic cleaning):

进行超声波清洗时, 应遵守下列条件: “洗涤槽容量: 20 瓦特输出功率 / 每升或以下; 洗涤时间: 最多 5 分钟; 不得直接振荡 PCB/PWB”。过度的超声波洗涤会导致引线的超载损坏。

To perform ultrasonic cleaning, observe the following conditions. Rinse bath capacity: Output of 20 watts per liter or less. Rinsing time: 5 minutes max. Do not vibrate the PCB/PWB directly. Excessive ultrasonic



# 圆片瓷介电容器 Ceramic Disc Capacitor

cleaning may lead to fatigue destruction of the lead wires

## △警告（使用与保管环境）Warning (use and storage environment)

电容器的绝缘涂层不形成完美的密封；因此，请勿在腐蚀性环境中使用或存放电容器，尤其是在氯气、硫气、酸、碱、盐等地方。同时应防潮。在对本产品进行清洗、覆膜或包装前，请先在指定设备上测试经清洗、覆膜或封膜的产品性能，以确认这些过程不会影响电容器的质量。电容器应存放在温度及相对湿度分别不超过-10 到 40 摄氏度及 15 至 85% 范围的地方。

The insulation coating of the capacitor does not form a perfect seal; Therefore, do not use or store capacitors in corrosive environments, especially in places where chlorine, sulfur, acid, alkali, salt, etc. exist. At the same time, it should be damp proof. Before cleaning, coating or packaging this product, please test the performance of the cleaned, coated or sealed product on the specified equipment to confirm that these processes will not affect the quality of the capacitor. Capacitors shall be stored in places with temperature and relative humidity not exceeding - 10 to 40 °C and 15 to 85% respectively.

使用本产品时如未能遵循上述警告事项，则在严重情况下，可能导致短路，并引起冒烟或局部离散。

If the above warnings are not followed when using this product, it may lead to short circuit, smoke or local dispersion in serious cases.

## △警告（焊接与安装）Warning (welding and installation)

### 1. 振荡与冲击 Oscillation and shock

使用时请勿使电容器或引线受到过度冲击或振动。过度冲击或振荡会对安装在电路板上的引线造成疲劳性破坏。请采取措施，使用粘合剂、封膜树脂或其它涂层将电容器安装在电路板上。使用指定设备进行固定时，请确认固定措施对产品不会造成影响。

Do not make capacitors or leads subject to excessive shock or vibration during use. Excessive shock or vibration will cause fatigue damage to the leads installed on the circuit board. Please take measures to install the capacitor on the circuit board with adhesive, sealing resin or other coating. When fixing with the specified equipment, please confirm that the fixing measures will not affect the product.

### 2. 焊接 welding

当将本产品焊接到 PCB/PWB 上时，不得超过电容器的焊接耐热性。如果本产品过热，可能导致内部连接点焊料熔化，并且可能导致热冲击，从而导致陶瓷元件破裂。当使用烙铁焊接电容器时，应遵循以下条件：

When welding this product to PCB/PWB, the welding heat resistance of capacitor shall not be exceeded. If the product is overheated, it may cause the solder at the internal connection point to melt, and may cause thermal shock, which may lead to the rupture of ceramic components. When soldering capacitors with soldering iron, the following conditions shall be observed:



# 圆片瓷介电容器 Ceramic Disc Capacitor

---

烙铁头温度：最高 400°C

Solder tip temperature: 400 °C maximum

烙铁功率：最大 50W

Soldering iron power: maximum 50W

焊接时间：最长 3.5 秒

Welding time: up to 3.5 seconds

### 3. 粘合、树脂封膜和树脂涂敷 Bonding, resin sealing and resin coating

在对本产品进行覆膜、封膜或施加涂层时，请先在指定设备上测试经覆膜、封膜或涂敷的产品的性能，以确认这些工艺不会影响电容器的质量。当含有有机溶剂（乙酸乙酯、甲基乙基酮、甲苯等等）的粘合剂和封膜树脂的使用量、干燥/硬化条件不适当时，有机溶剂可能损坏电容器的外涂层树脂，最坏情况下可能导致短路。粘合剂、封膜树脂或涂层的厚度变化可能导致处于温度周期变化中的电容器的外涂层树脂破裂或陶瓷元件破裂。

When covering, sealing or coating this product, please first test the performance of the coated, sealed or coated product on the specified equipment to confirm that these processes will not affect the quality of the capacitor. When the amount of adhesive and sealing resin containing organic solvent (ethyl acetate, methyl ethyl ketone, toluene, etc.) is used and the drying/hardening conditions are not suitable, the organic solvent may damage the external coating resin of the capacitor, which may lead to short circuit in the worst case. Changes in the thickness of adhesives, sealing resins, or coatings may result in cracking of the outer coating resin or ceramic components of capacitors that are experiencing periodic changes in temperature.

### 4. 粘合、树脂封膜和树脂涂敷后的处理 Treatment after bonding, resin sealing film and resin coating

焊接后，当外涂层很热（超过 100°C）时，外涂层会变得很软、易碎。因此，请注意不要对涂层施加机械冲击力。

After welding, when the outer coating is very hot (more than 100 °C), the outer coating will become very soft and fragile. Therefore, be careful not to apply mechanical impact to the coating.

使用本产品时如未能遵循上述警告事项，则在严重情况下，可能导致短路，并引起冒烟或局部离散。

If the above warnings are not followed when using this product, it may lead to short circuit, smoke or local dispersion in serious cases.

---

---