

Features

- Ultra low capacitance: 0.5pF typical (IO to IO)
- Ultra low leakage: nA level
- Low operating voltage: 15V
- Complies with following standards:
 - – IEC 61000-4-2 (ESD) immunity test
 - Air discharge: $\pm 15\text{kV}$
 - Contact discharge: $\pm 8\text{kV}$
 - – IEC 61000-4-5 (Lightning) 3A (8/20 μs)
- RoHS Compliant

Mechanical Characteristics

- Package: SOT-523
- Lead Finish: Matte Tin
- Case Material: "Green" Molding Compound.
- Moisture Sensitivity: Level 3 per J-STD-020
- Terminal Connections: See Diagram Below
- Shipping Qty : 3000pcs/7Inch Tape & Reel

Applications

- Laptop Computers
- Cellular Phones
- Digital Cameras
- Personal Digital Assistants (PDAs)

Dimensions and Pin Configuration

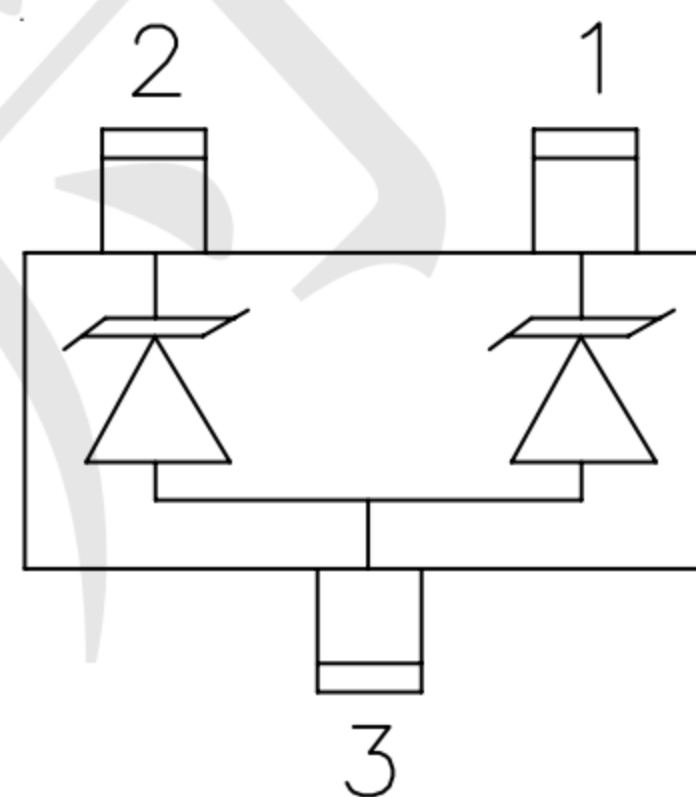
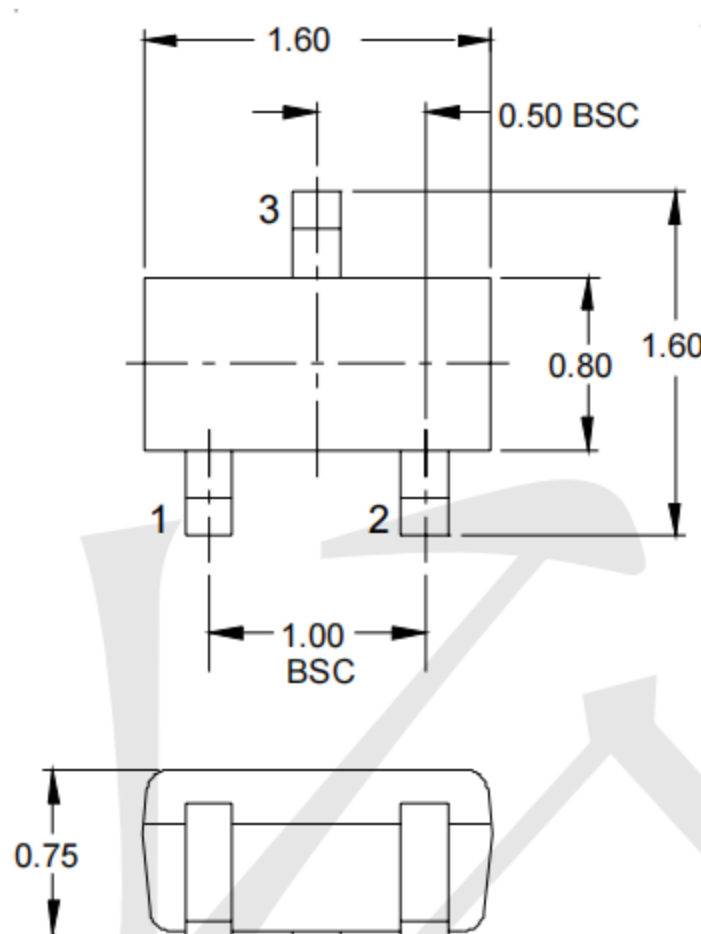

Marking: P6

Absolute Maximum Ratings (Tamb=25°C unless otherwise specified)

| Parameter | Symbol | Value | Unit |
|---------------------------------|--------|-------------|------|
| Peak Pulse Power (8/20μs) | Ppk | 100 | W |
| Peak Pulse Current (8/20μs) | Ipp | 3 | A |
| ESD per IEC 61000-4-2 (Air) | VESD | ±15 | kV |
| ESD per IEC 61000-4-2 (Contact) | | ±8 | |
| Operating Temperature Range | TJ | -55 to +125 | °C |
| Storage Temperature Range | Tstg | -55 to +150 | °C |

Electrical Characteristics (TA=25°C unless otherwise specified)

| Parameter | Symbol | Min | Typ | Max | Unit | Test Condition |
|-------------------------|--------|------|-----|-----|------|---------------------------------------|
| Reverse Working Voltage | VRWM | | | 15 | V | |
| Breakdown Voltage | VBR | 16.5 | | | V | IT = 1mA |
| Reverse Leakage Current | IR | | | 0.2 | μA | VRWM = 15V |
| Clamping Voltage | VC | | | 28 | V | I _{PP} = 1A (8 x 20us pulse) |
| Clamping Voltage | VC | | | 30 | V | I _{PP} = 3A (8 x 20us pulse) |
| Junction Capacitance | CJ | | 1 | 1.2 | pF | Vr=0V ,f=1MH Pin1 or 2 to Pin3 |
| | | | 0.5 | | pF | Vr=0V ,f=1MH Pin1 to Pin2 |

Typical Performance Characteristics ($T_A=25^\circ\text{C}$ unless otherwise Specified)

Fig1. 8/20 μs Pulse Waveform

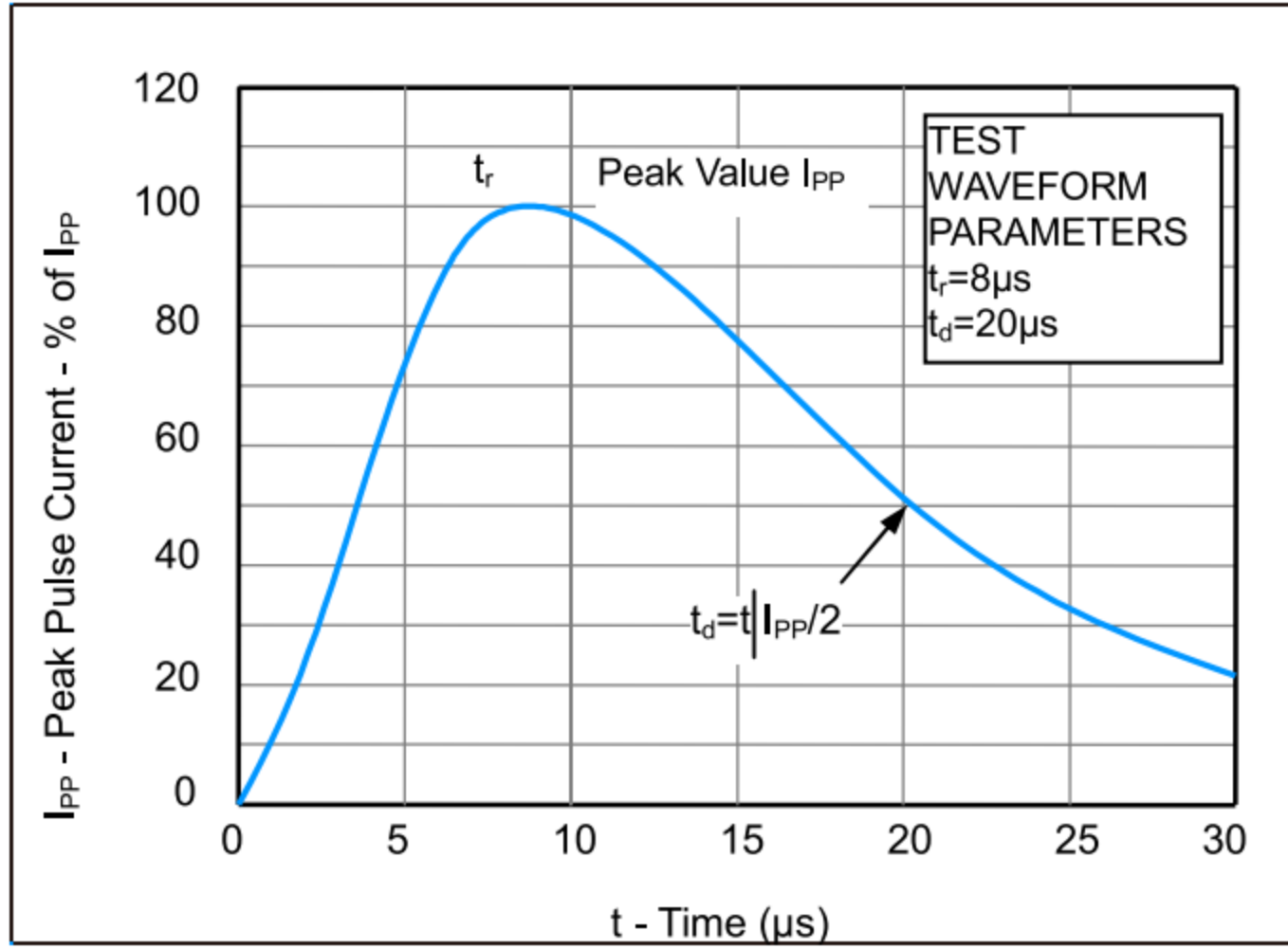

Fig2. ESD Pulse Waveform (according to IEC 61000-4-2)

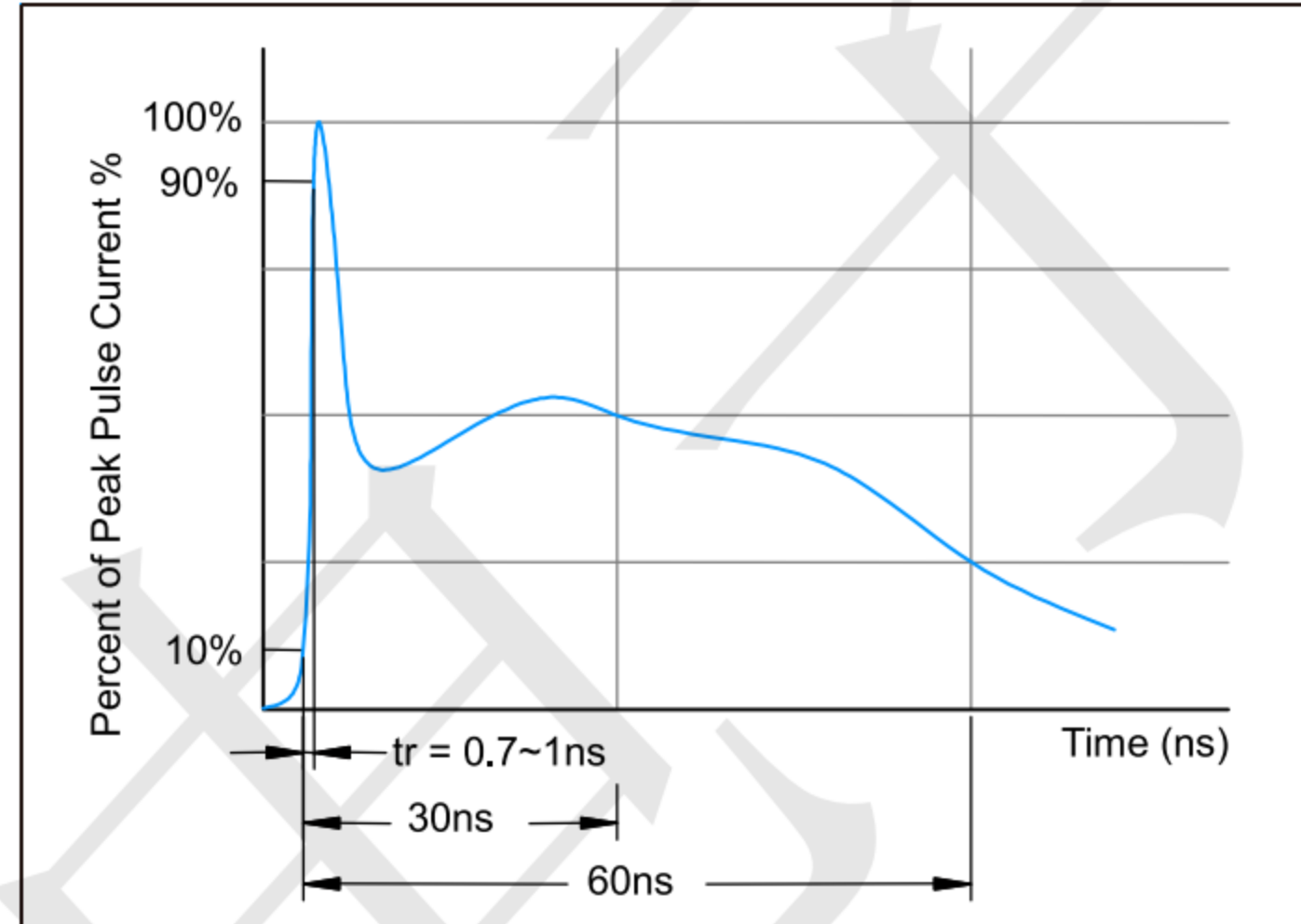
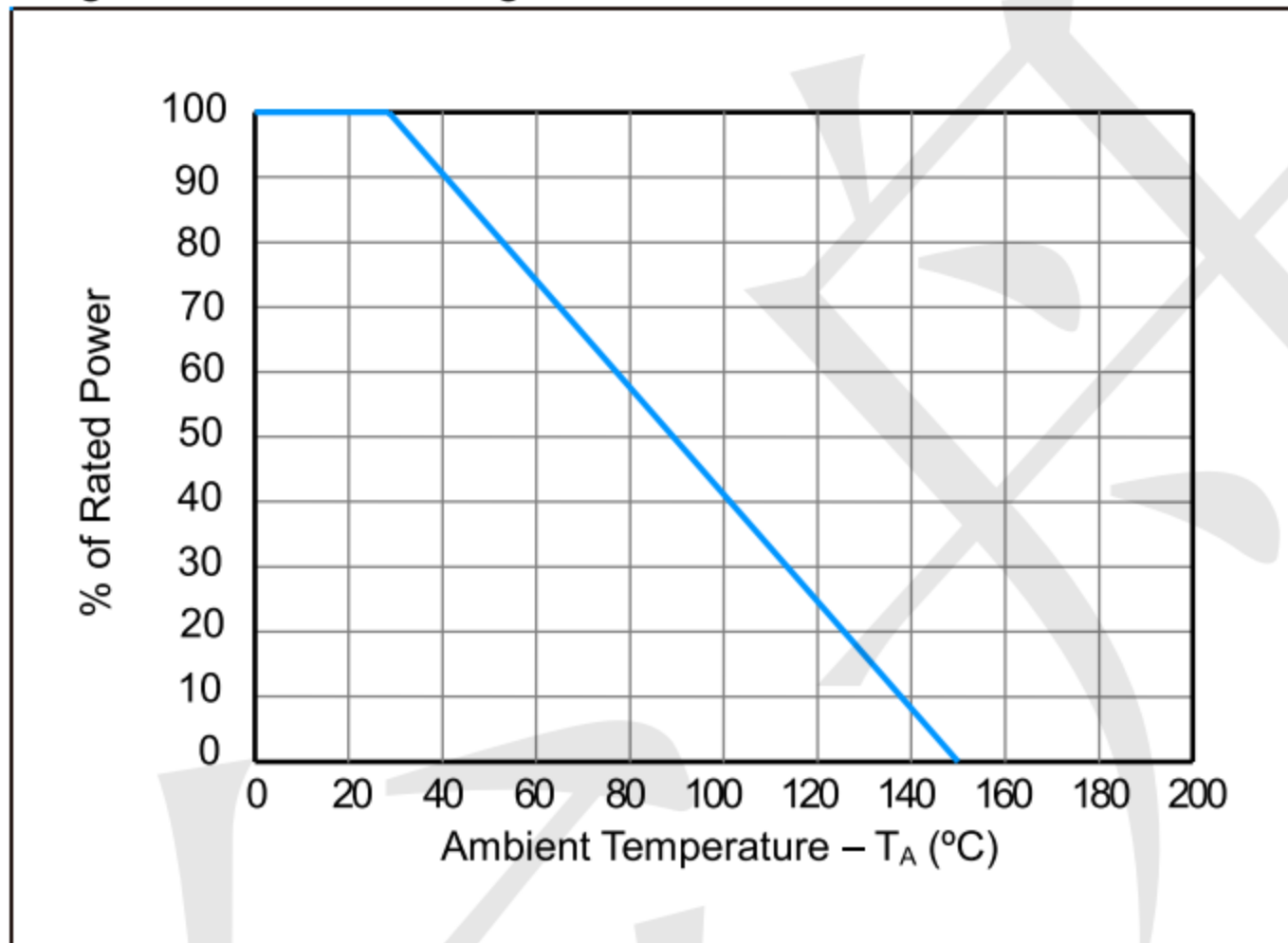
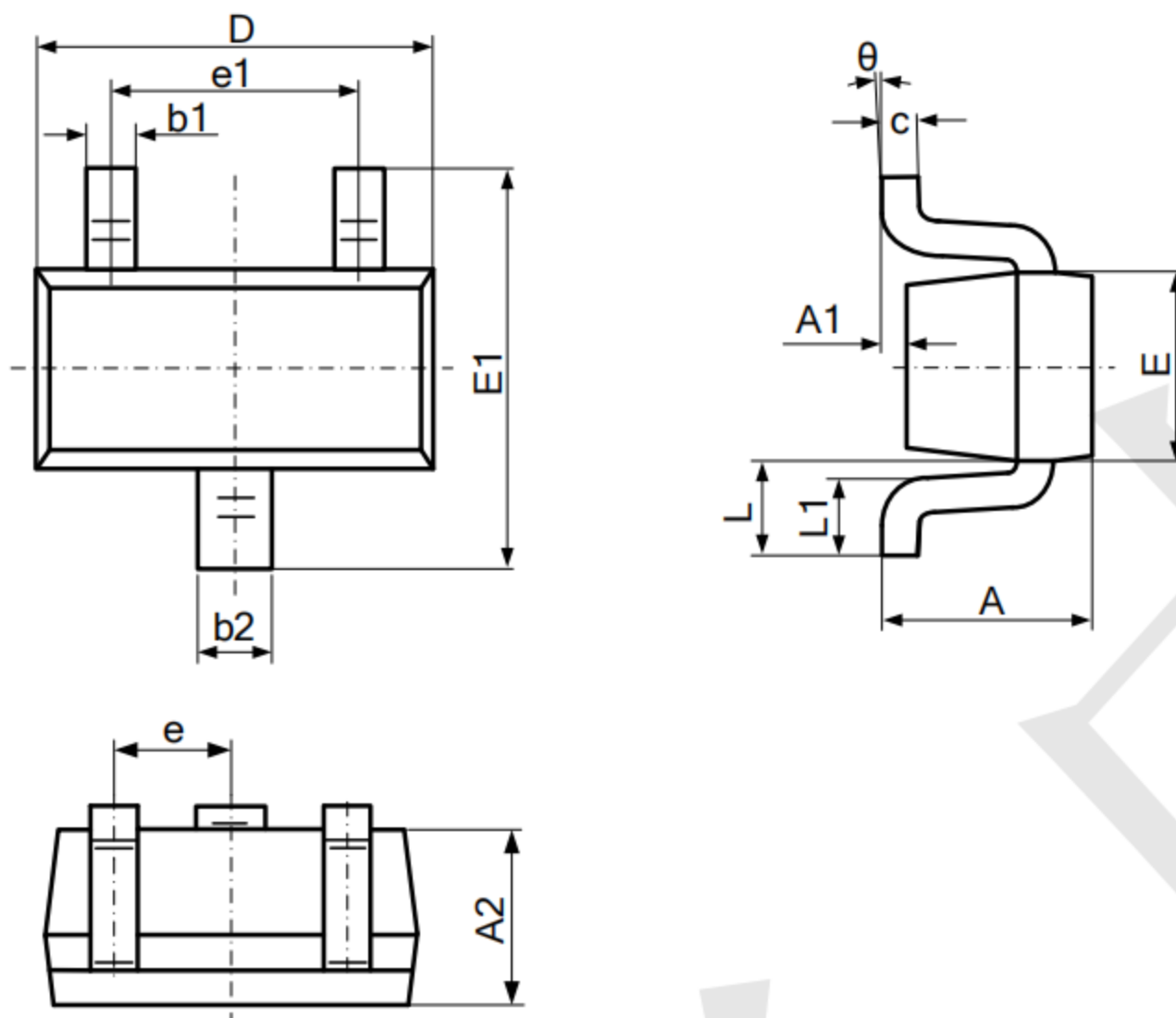

Fig3. Power Derating Curve



Outline Drawing - SOT-523



| SYMBOL | DIMENSIONS | | | |
|--------|------------|-------|-----------|-------|
| | MILLIMETER | | INCHES | |
| | MIN | MAX | MIN | MAX |
| A | 0.700 | 0.900 | 0.028 | 0.035 |
| A1 | 0.000 | 0.100 | 0.000 | 0.004 |
| A2 | 0.700 | 0.800 | 0.028 | 0.031 |
| b1 | 0.150 | 0.250 | 0.006 | 0.010 |
| b2 | 0.250 | 0.325 | 0.010 | 0.013 |
| c | 0.100 | 0.200 | 0.004 | 0.008 |
| D | 1.500 | 1.700 | 0.059 | 0.067 |
| E | 0.750 | 0.850 | 0.030 | 0.033 |
| E1 | 1.450 | 1.750 | 0.057 | 0.069 |
| e | 0.950 BSC | | 0.037 BSC | |
| e1 | 0.900 | 1.100 | 0.035 | 0.043 |
| L | 0.300 | 0.500 | 0.012 | 0.020 |
| L1 | 0.028 | 0.440 | 0.011 | 0.017 |
| θ | 0 | 8° | 0 | 8° |

Land Pattern - SOT-523

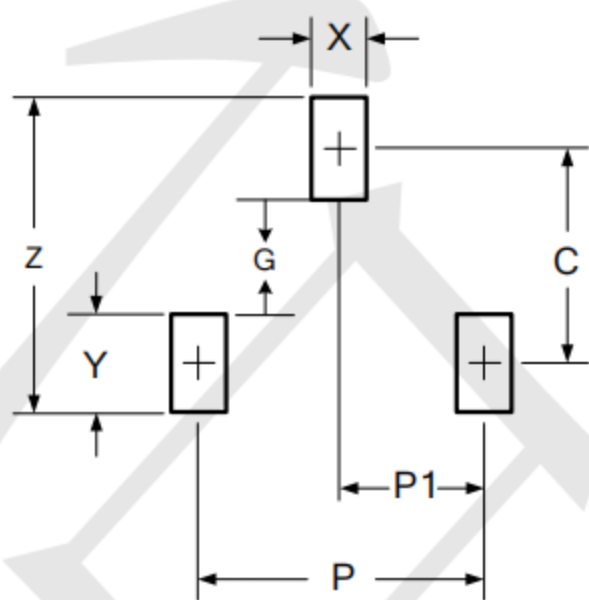

| DIM | DIMENSIONS | |
|-----|------------|-------------|
| | INCHES | MILLIMETERS |
| C | .055 | 1.40 |
| P | .039 | 1.00 |
| P1 | .020 | 0.50 |
| G | .024 | 0.60 |
| X | .016 | 0.40 |
| Y | .031 | 0.80 |
| Z | .087 | 2.20 |