

客户 (Customer) : _____

承认书

Approval Sheet

谨致执事者：兹提供敝公司之有关详细规格及图面数据，敬请给予办理试认定手续。
同时敬请送返一份附有贵公司签认之测试认定后之样品承认书。

We are pleased in sending you herewith on specification and drawings for your approval.
Please return to us one copy "Approval sheet" with your approved signature.

型号 (Model No.) : A-SC633GHC-H01-2T

发文日期 (Issue Date) : 2019/10/21 承认日期 (Approved Date) : _____

Checking signature of Amicc

Designer	Checker	Approver
Mars	<i>Tommy</i>	Solarliu

Approval signature of customer

Designer	Checker	Approver

江苏欧密格光电科技股份有限公司

Jiangsu Amicc Opto-Electronics Technology Co.,Ltd.

地址：江苏省常州市武进区武南中路 98 号

Add: 98.Wu Nan Road, Wujin, Changzhou city, Jiangsu Province

TEL:0086-519-89806999

FAX:0086-519-86523668

Top view LED Type ■ PLCC Package

A-SC633GHC-H01-2T

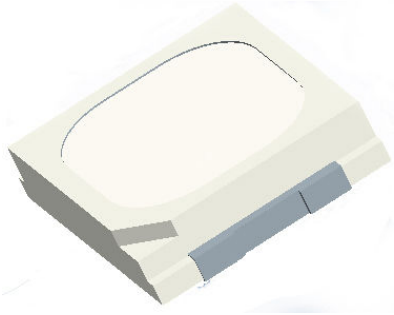

■ Description

The Amicc 633 package has high efficacy, low power consumption, wide viewing angle and a compact form factor. These features make this package to be an ideal LED for all lighting applications.

■ Features

- Top view LED
- High luminous Intensity output
- Wide viewing angle
- Pb-free
- RoHS compliant
- JEDEC MSL 3

■ Applications

- General lighting
- Decorative and Entertainment Lighting
- Indicators
- Illumination
- Switch lights

■ Device Selection Guide

Chip Materials	Emitted Color	Resin Color
InGaN	Green	Water Clear

■ Package Dimensions

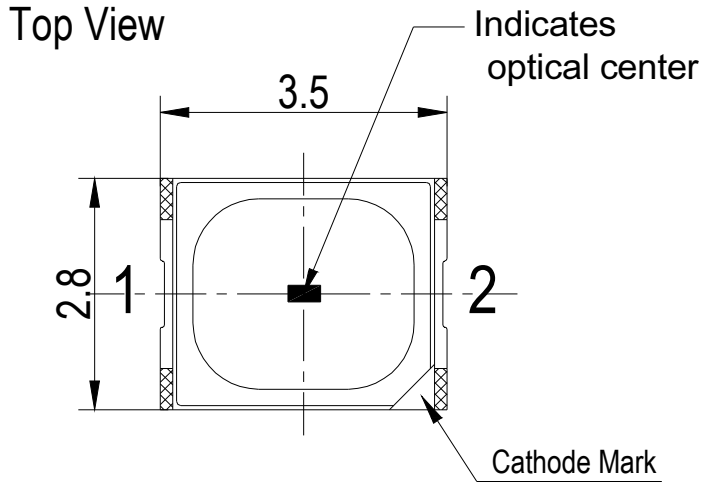

Side View



Side View

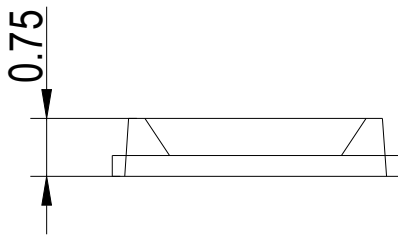

Polarity

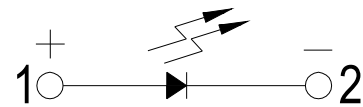

Bottom View

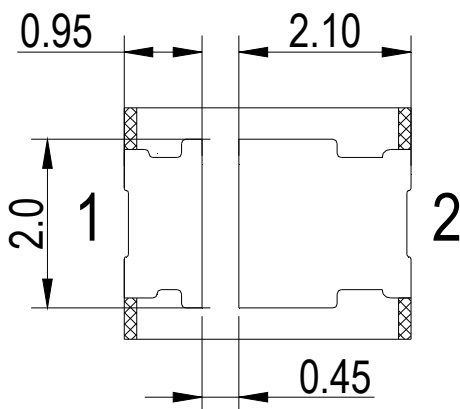

Recommended solder pad

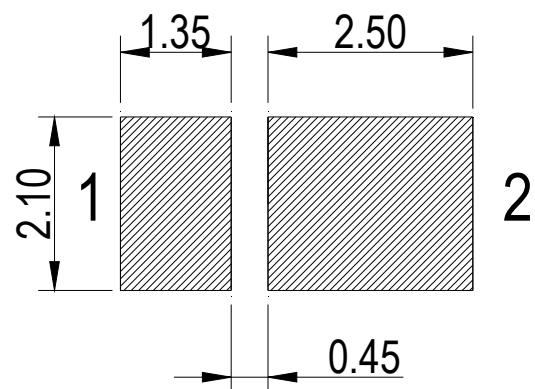

Note:
 Tolerance unless mentioned is ± 0.1 mm, Unit = mm.

■ **Absolute Maximum Ratings (T_{Soldering}=25°C)**

Parameter	Symbol	Rating	Unit
Forward Current	I _F	60	mA
Peak Forward Current (Duty 1/10 @1ms)	I _{FP}	120	mA
Power Dissipation	P _d	200	mW
Operating Temperature	T _{opr}	-40 ~ +85	°C
Storage Temperature	T _{stg}	-40 ~ +100	°C
Soldering Temperature	T _{sol}	Reflow Soldering : 260 °C for 10 sec. Hand Soldering : 350 °C for 3 sec.	

Note:
 The products are sensitive to static electricity and must be carefully taken when handling products.

■ **Electro-Optical Characteristics (T_{Soldering}=25°C)**

Parameter	Symbol	Min.	Typ.	Max.	Unit	Condition
Luminous Flux	I _v	20	24	33	lm	I _F =60mA
Peak Wavelength	λ _p	-----	520	-----	nm	I _F =60mA
Dominant Wavelength	λ _d	516	-----	525	nm	I _F =60mA
Forward Voltage	V _F	2.3	-----	3.2	V	I _F =60mA
Viewing Angle	2θ _{1/2}	-----	120	-----	deg	I _F =60mA
Reverse Current	I _R	-----	-----	10	μA	V _R =5V

Notes:
 1. Tolerance of Luminous Flux: ±10%.
 2. Tolerance of Dominant Wavelength: ±1nm.
 3. Tolerance of Forward Voltage: ±0.1V.

■ **Bin Range of Luminous Flux**

Bin Code	Min.	Max.	Unit	Condition
L13	20	23	lm	I _F =60mA
L14	23	27		
L15	27	33		

Notes:
Tolerance of Luminous Flux: ±10%.

■ **Bin Range of Forward Voltage**

Bin Code	Min.	Max.	Unit	Condition
B6	516	519	nm	I _F =60mA
B7	519	522		
B8	522	525		

Note:
Tolerance of Dominant Wavelength: ±1nm

■ **Bin Range of Chromaticity Coordinates**

Bin Code	Min.	Max.	Unit	Condition
32	2.4	2.6	V	I _F =60mA
34	2.6	2.8		
36	2.8	3.0		
38	3.0	3.2		

Note:
Tolerance of Forward Voltage: ±0.1V.

■ **Spectrum Distribution**

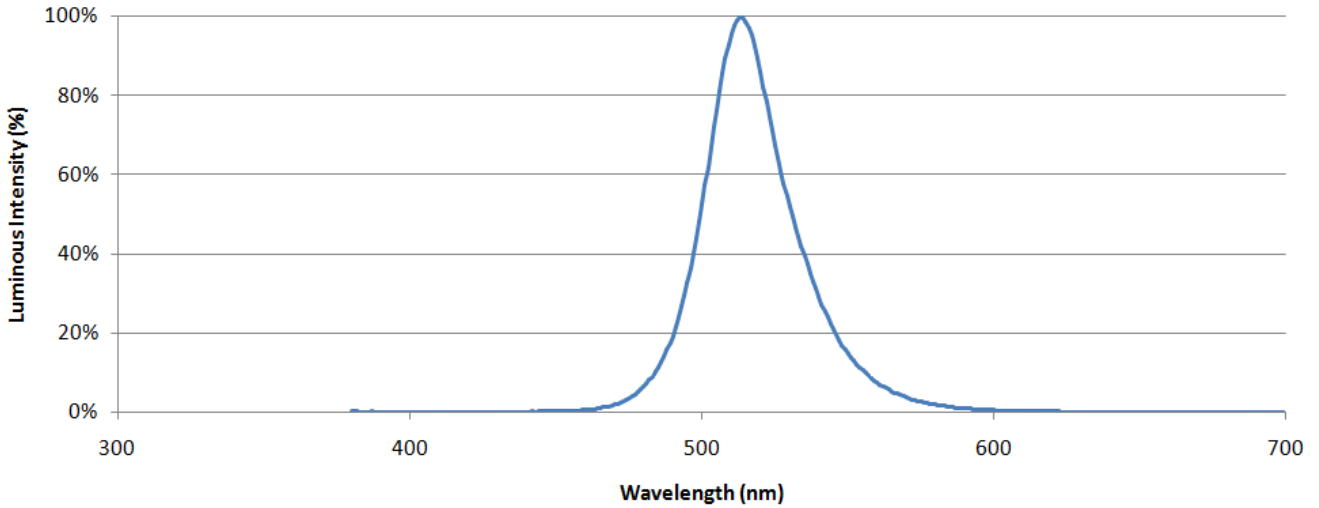

■ **Typical Electro-Optical Characteristics Curves**

Fig.1-Forward Voltage Shift vs. Junction Temperature

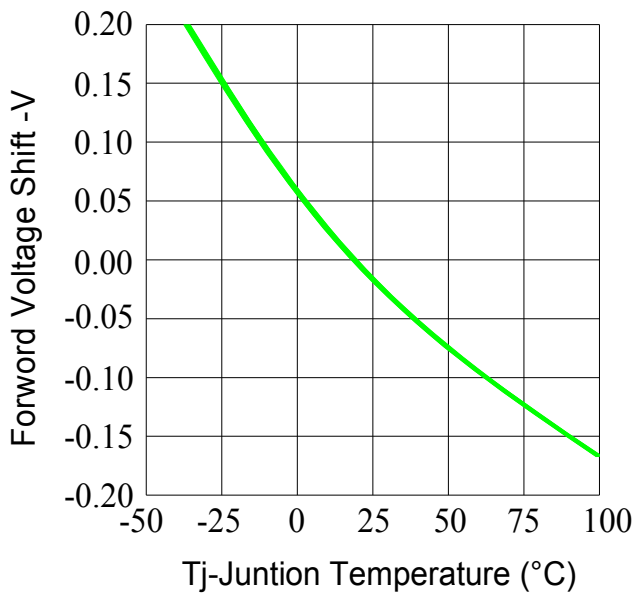
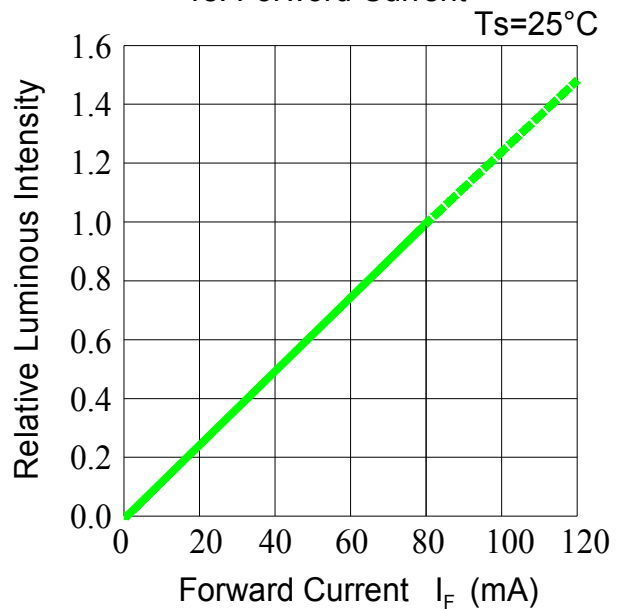

Fig.2-Relative Luminous Intensity vs. Forward Current



Typical Electro-Optical Characteristics Curves

Fig.3-Relative Luminous Intensity vs.Juntion Temperature

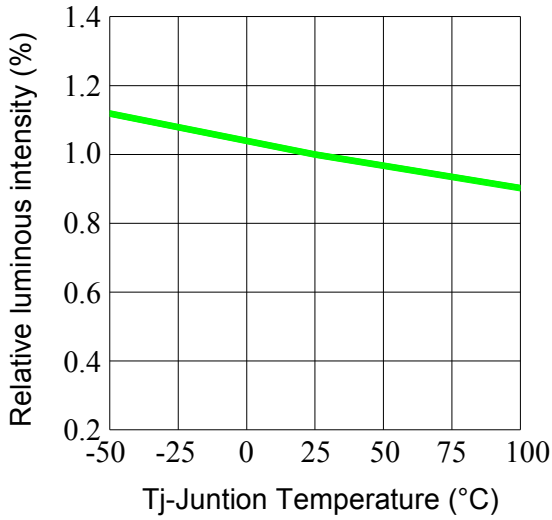

Fig.4-Forward Current vs. Forward Voltage $T_a=25^\circ\text{C}$

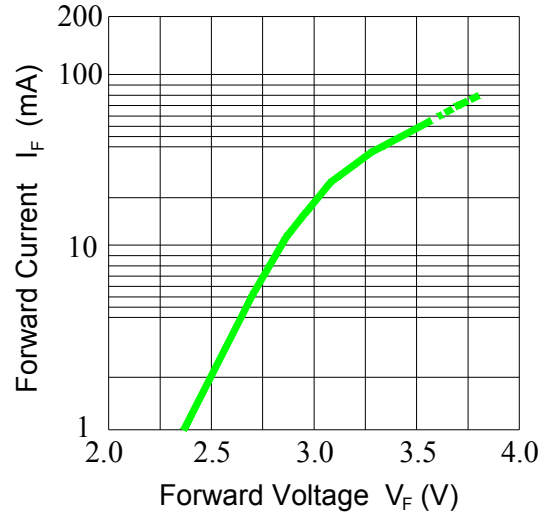

Fig.5-Max.Driving Forward Current vs.Soldering Temperature

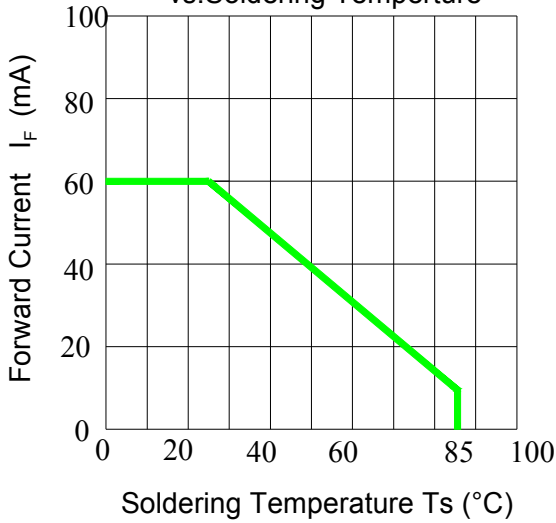
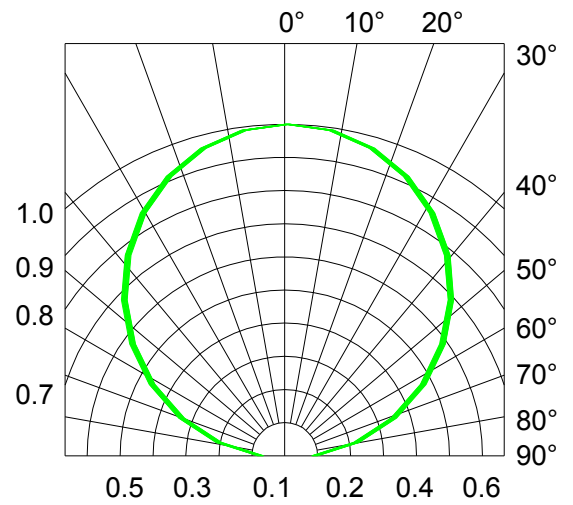
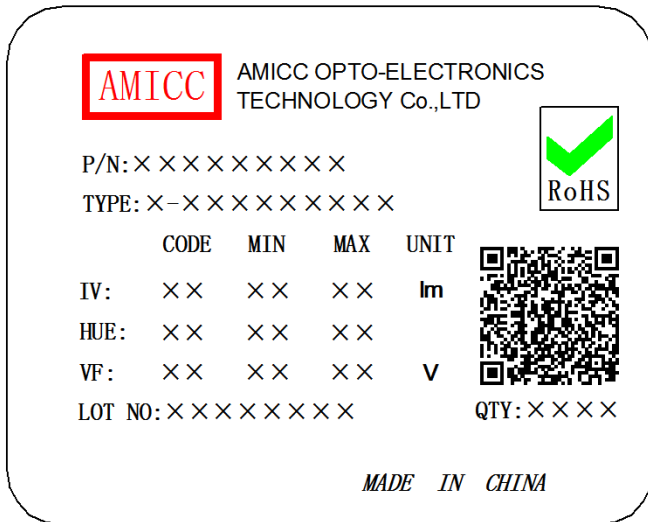

Fig.6-Radiation Diagram $T_a=25^\circ\text{C}$



■ **Moisture Resistant Packing Materials**

1. **Label Explanation**



- CPN: Customer's Product Number
- P/N: Product Number
- TYPE: Part NO.
- IV: Luminous Intensity Rank
- HUE: Chromaticity Coordinates Rank
- VF: Forward Voltage Rank
- LOT No: Lot Number
- QTY: Packing Quantity

2. **Reel Dimensions**

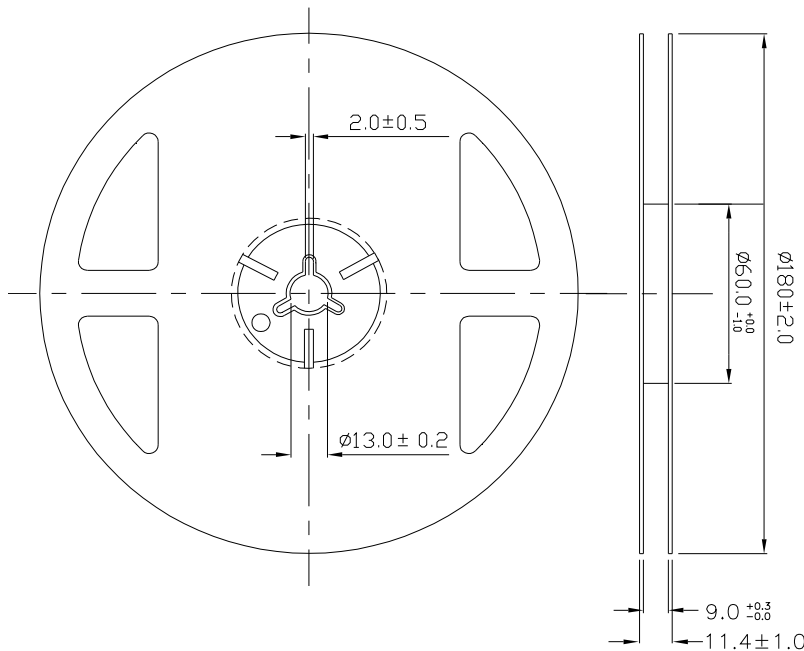

Note:
 Tolerances unless mentioned ±0.1mm, Unit = mm.

3. Carrier Tape Dimensions: Loaded Quantity 2000 pcs Per Reel

Polarity Direction

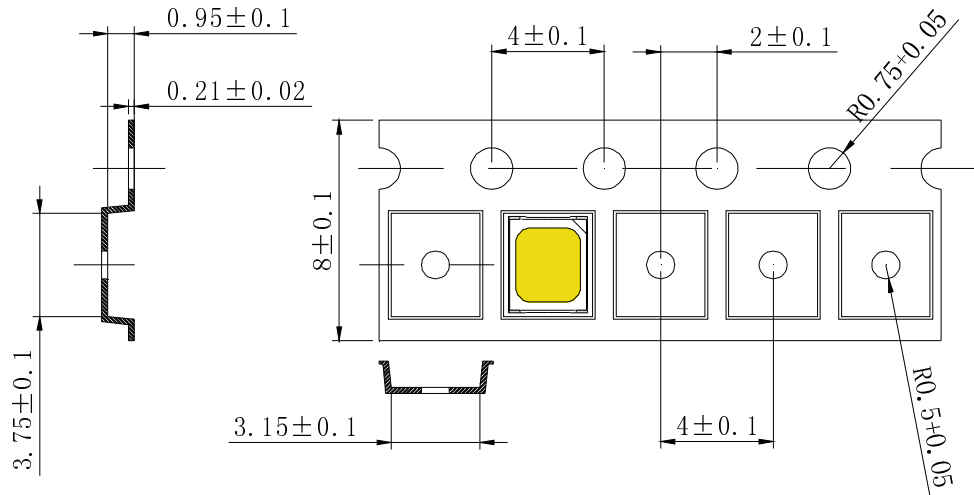
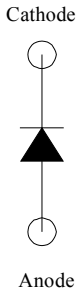

Notes:

1. Tolerance unless mentioned is ± 0.1 mm; Unit = mm.
2. Minimum packing amount is 1000 pcs per reel.

4. Moisture Resistant Packing Process

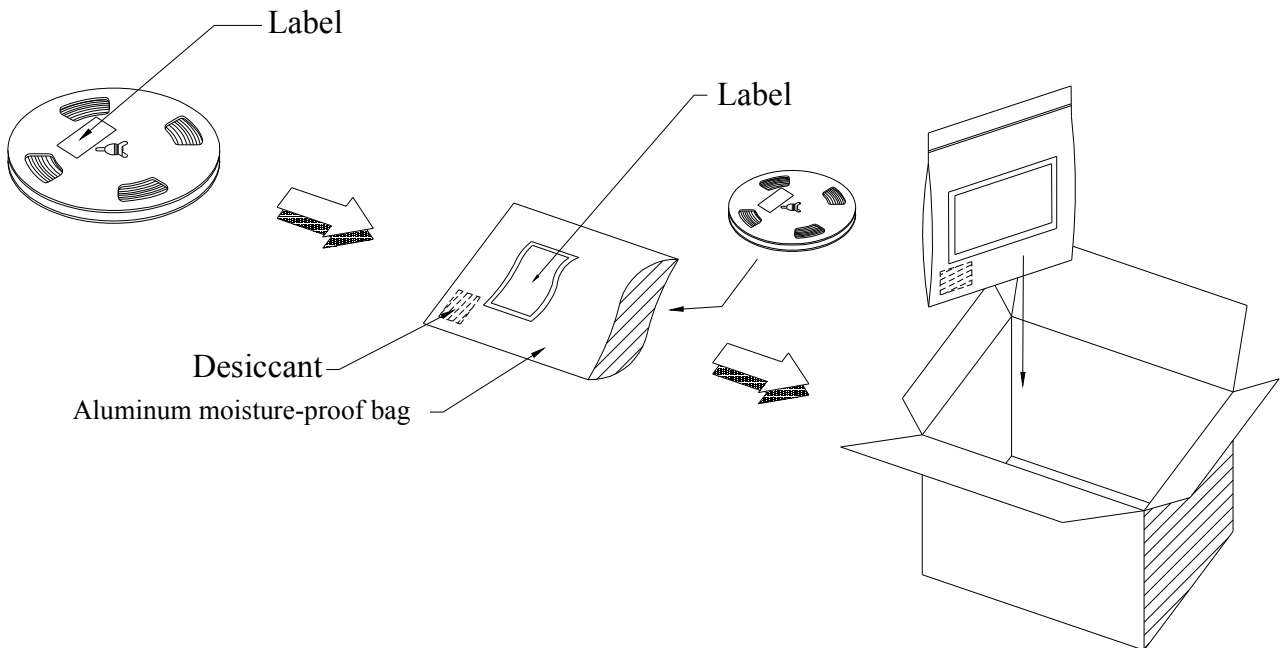

■ **Reliability Test Items and Conditions**

The reliability of products shall be satisfied with items listed below.

Confidence level : 90%

LTPD : 10%

No.	Items	Test Condition	Test Hours/Cycles	Sample Size	Ac/Re
1	Reflow Soldering	Temp. : 260°C/10sec.	6 Min.	22 PCS.	0/1
2	Thermal Shock	H : +100°C 5min ∫ 10 sec L : -10°C 5min	300 Cycles	22 PCS.	0/1
3	Temperature Cycle	H : +100°C 15min ∫ 5 min L : -40°C 15min	300 Cycles	22 PCS.	0/1
4	High Temperature/Humidity Reverse Bias	Ta=85°C,85%RH	1000 Hrs.	22 PCS.	0/1
5	Low Temperature Storage	Ta=-40°C	1000 Hrs.	22 PCS.	0/1
6	High Temperature Storage	Ta=100°C	1000 Hrs.	22 PCS.	0/1
7	DC Operation Life	Ta=25°C I _F = 60 mA	1000 Hrs.	22 PCS.	0/1

■ Precautions for Use

1. Over-current-proof

Customer must apply resistors for protection; otherwise slight voltage shift will cause big current change (Burn out will happen).

2. Storage

2.1 Do not open moisture proof bag before the products are ready to use.

2.2 Before opening the package: The LEDs should be kept at 30°C or less and 90%RH or less.

2.3 After opening the package: The LED's floor life is 168 Hrs under 30°C or less and 60% RH or less. If unused LEDs remain, it should be stored in moisture proof packages.

2.4 If the moisture absorbent material (silica gel) has faded away or the LEDs have exceeded the storage time, baking treatment should be performed using the following conditions.

Baking treatment: 60±5°C for 24 hours.

3. Soldering Condition

3.1 Pb-free solder temperature profile

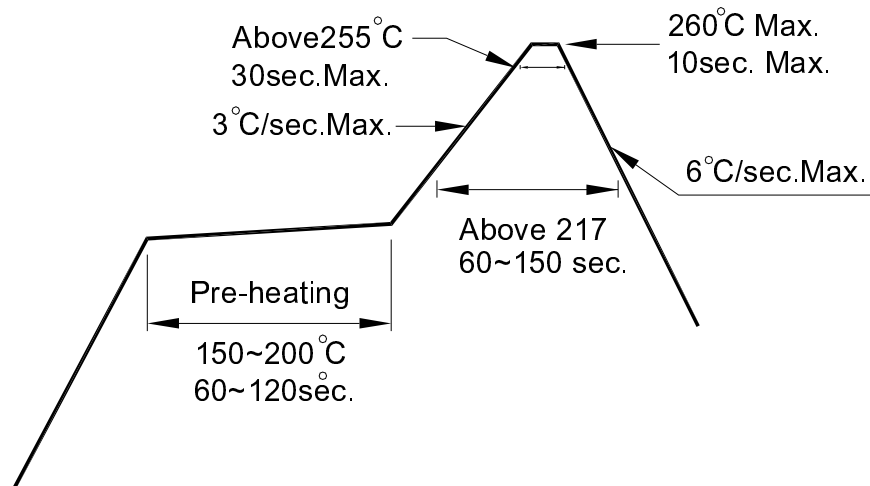

3.2 Reflow soldering should not be done more than two times.

3.3 When soldering, do not put stress on the LEDs during heating.

3.4 After soldering, do not warp the circuit board.

4. Soldering Iron

Each terminal is to go to the tip of soldering iron temperature less than 350°C for 3 seconds within once in less than the soldering iron capacity 25W. Leave two seconds and more intervals, and do soldering of each terminal. Be careful because the damage of the product is often started at the time of the hand solder.

5. Repairing

Repair should not be done after the LEDs have been soldered. When repairing is unavoidable, a double-head soldering iron should be used (as below figure). It should be confirmed beforehand whether the characteristics of the LEDs will or will not be damaged by repairing.

