

3000W FAN COOLED

AC-DC POWER SUPPLIES

The HDL3000 series offers users both output voltage and output current programming (0 – 105%) via resistance, voltage or I²C bus in a very high efficiency, high power density 3kW chassis mount package. Measuring just 6.69" x 2.52" x 11.02", the HDL3000 also features active current sharing, remote on/off, remote sense and a power OK signal. The standby output is available whenever the mains supply is present and can be user selected as either 5V at 0.5A or 9V at 0.3A.



Features

- High efficiency up to 93%
- High power density
- DC outputs from 12-60VDC
- Programmable output voltage (0-105%)
- Programmable output current (0-105%)
- I²C interface
- Parallel operation
- Fully featured signals & controls
- 3 year warranty

Applications



Industrial
Electronics
& Robotics



Lasers



LED Heating

Dimensions

6.69" x 2.52" x 12.48"

(170.0 x 64.0 x 317.0mm) including connectors

Models & Ratings

Model Number	Output Power		Output Voltage	Output Current		Ripple & Noise	Efficiency ⁽¹⁾
	High Line	Low Line		High Line	Low Line		
HDL3000PS12	2400W	1600W	12.0VDC	200.0A	166.6A	150mV	88%
HDL3000PS15	2400W	1600W	15.0VDC	160.0A	133.3A	150mV	89%
HDL3000PS24	3000W	2000W	24.0VDC	125.0A	83.3A	240mV	91%
HDL3000PS30	3000W	2000W	30.0VDC	100.0A	66.6A	300mV	91%
HDL3000PS36	3000W	2000W	36.0VDC	83.5A	55.5A	360mV	92%
HDL3000PS48	3000W	2000W	48.0VDC	62.5A	41.6A	480mV	92%
HDL3000PS60	3000W	2000W	60.0VDC	50.0A	33.3A	600mV	93%

Notes:

1. Measured with 230VAC input and full load.

Input

Characteristic	Minimum	Typical	Maximum	Units	Notes & Conditions
Input Voltage	90		264	VAC	See derating curve
Input Frequency	47		63	Hz	
Power Factor		0.98/0.95			115/230VAC full load
Input Current			19.7/15.0	A	115VAC at 2000 W/230VAC at 3000W
Inrush Current			43/110	A	115/230VAC
Earth Leakage Current			3	mA	264 VAC/60Hz

Output

Characteristic	Minimum	Typical	Maximum	Units	Notes & Conditions
Output Voltage	12		60	VDC	See Models and Ratings table
Output Trim		±5		%	By potentiometer
Output Voltage Program	0		105	%	Of rated output
Output Current Program	0		105	%	Of rated output
Voltage Tolerance ⁽¹⁾			±2	%	Of rated output voltage ⁽¹⁾
Current Tolerance ⁽¹⁾			±3	%	Of rated output current ⁽¹⁾
Minimum Load	0			A	
Start Up Delay			1	s	
Start Up Rise Time			120	ms	At full load
Hold Up Time	10	11		ms	At 230VAC and full load
Line Regulation			±1	%	
Load Regulation			±1 (V1) /±3	%	V1 Standby. 0-100% load
Transient Response		<1		%	For a 25% step load change
Ripple & Noise	150		600	mV pk-pk	See models and ratings table. Measured with 20MHz bandwidth and using 12" twisted pair wire terminated with 0.1µF ceramic capacitor and 47µF electrolytic at 25°C ambient.
Overvoltage Protection	Tracks output voltage, see application notes. Recycle AC to reset.				
Overtemperature Protection	Primary and secondary heatsinks, monitored. Output shuts down, auto recovers				
Overload Protection		105			Rated power, constant current.
Short Circuit Protection	Auto recovery.				
Temperature Coefficient		±0.02		%/°C	0-50°C
Remote Sense	Compensates for 0.5V max voltage drop, if remote sense is not required, local sense must be used				
Enable	Output must be enabled, see application notes, power supply is shipped with enable links fitted				
Current Share	5 supplies can share within 5%				
Standby Output	5V at 0.5A, present whenever AC is applied (9V at 0.3A, user selectable, by connecting 'VSET', Pin 8 of CN2 to GND)				

Notes:

1. Tolerance includes setup time tolerance, line regulation and load regulation.

Output Voltage Programming

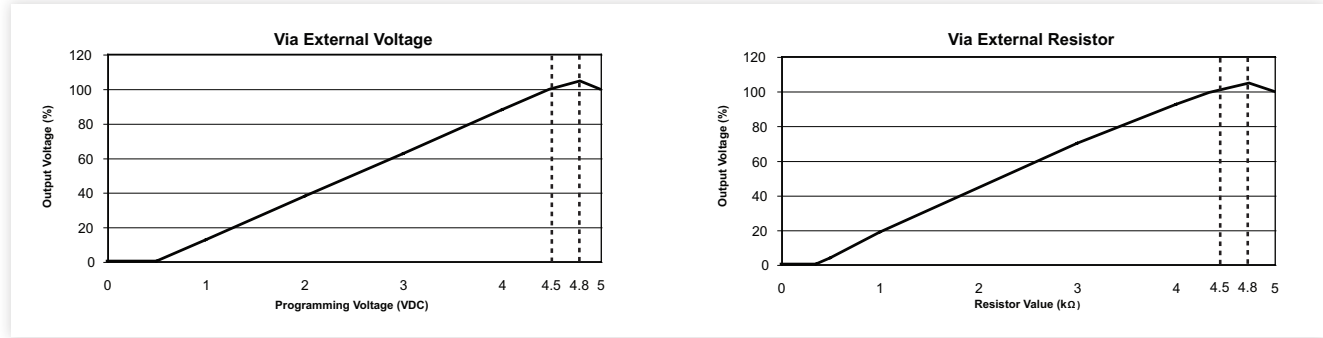

Output Current Programming

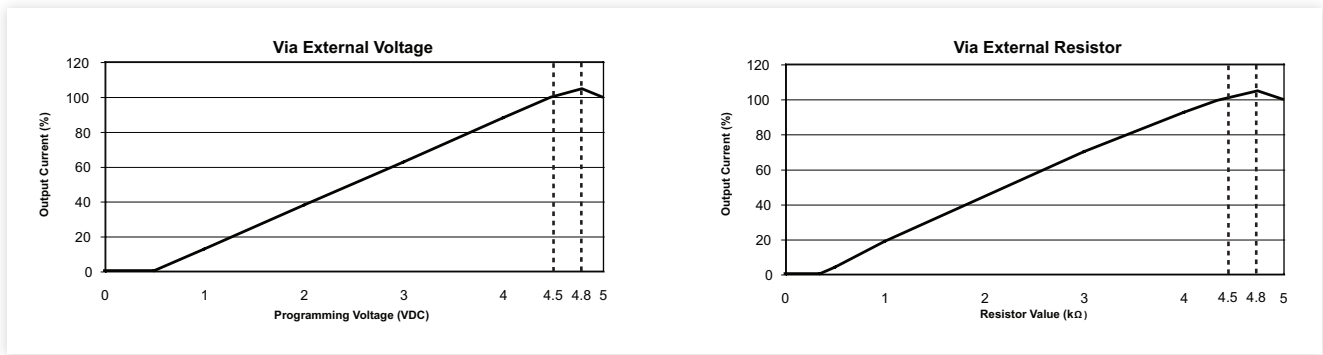

Output Voltage/Current Programming

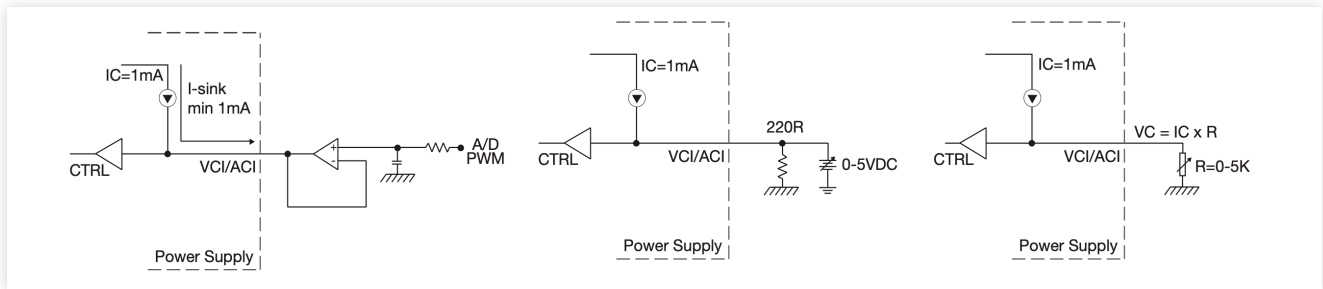

General

Characteristic	Minimum	Typical	Maximum	Units	Notes & Conditions
Efficiency	88		93	%	See Models and Ratings table.
Isolation: Input to Output	3000			VAC	
Input to Ground	1500			VAC	
Output to Ground	500			VAC	
Switching Frequency	40	65	200	kHz	PFC. PWM, variable.
Power Density			14.4	W/in ³	
Signals and Controls	Enable, Current Share, V Program, I Program, 5V Standby, Power OK.				
Mean Time Between Failure		90		khrs	MIL-HDBK-217F, 25°C GB.
Weight		7.94 (3.6)		lb (kg)	

Environmental

Characteristic	Minimum	Typical	Maximum	Units	Notes & Conditions
Operating Temperature	-20		60	°C	Derate linearly from 100% load at 50°C to 50% load at 60°C.
Storage Temperature	-40		+85	°C	
Cooling	Internal fan fitted, speed increases with load and internal temperature.				
Humidity	20		90	%RH	Non-condensing
Operating Altitude			3100	m	
Vibration			2	g	10-500Hz, 10 min/cycle, 60 min period for each axis, compliant to IEC60068-2-16, IEC 60068-2-64.

Derating Curve

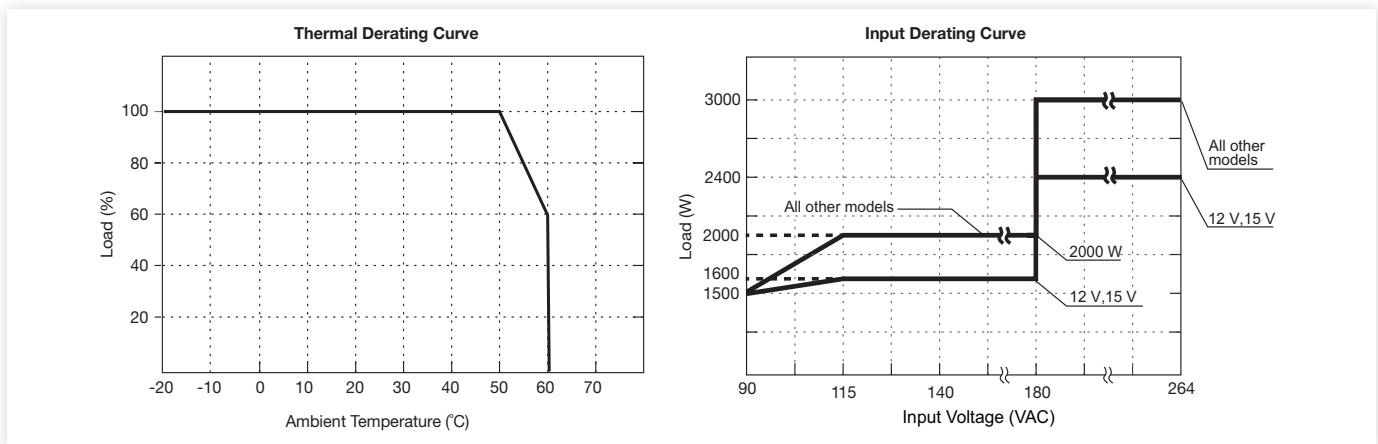

Signals & Controls

Characteristic	Output Status
Solid (Green)	DC Output OK
Solid (Orange)	DC Output OK in remote control mode
Slow Blink (Green)	Output Not Enabled
Slow Blink (Orange)	Output Not Enabled in remote control mode
Fast Blink (Red)	Over Voltage
Solid (Red)	Over Loaded
Slow Blink (Red)	Over Temperature
Intermittent Blink (Red)	Fan Fail
Short & Long Blink (Red)	AUX Standby Failure

Remote Enable

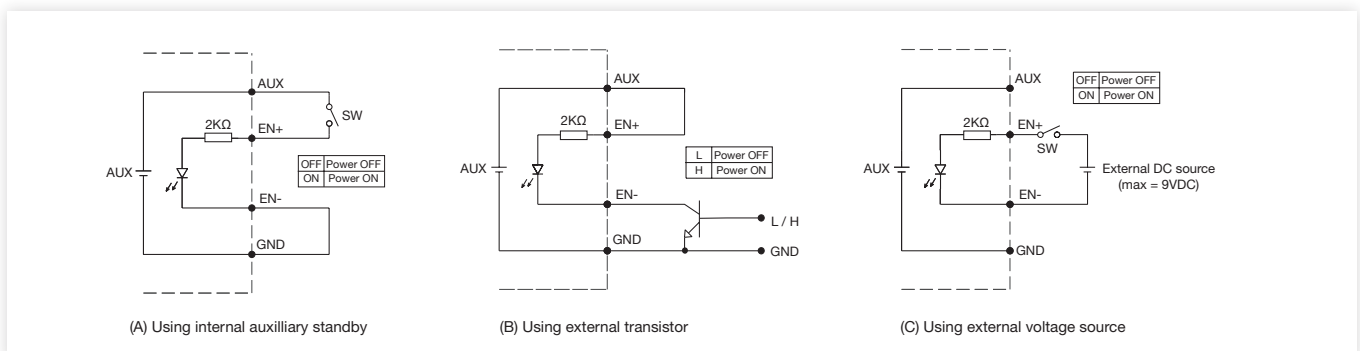

*GND shown in above diagram is referring to the GND of CN5, not the grounding from output power (NEG (-))

EMC: Emissions

Phenomenon	Standard	Test Level	Notes & Conditions
Conducted	EN55032	Class A	
Radiated	EN55032	Class A	
Harmonic Currents	EN61000-3-2	Class A	
Voltage Flicker	EN61000-3-3		

EMC: Immunity

Phenomenon	Standard	Test Level	Criteria	Notes & Conditions
ESD Immunity	EN61000-4-2	2 / 3	A	±4kV contact / ±8kV air discharge
Radiated Immunity	EN61000-4-3	3	A	
EFT	EN61000-4-4	3	A	10V/m
Surge	EN61000-4-5	Installation class 3	A	
Conducted	EN61000-4-6	3	A	10V
Dips	EN55024	Dip: 30% 500ms	A	30A/m
Interrupt		Int. >95% 10ms	A	
		Int. >95% 5000ms	B	

Safety Approvals

Safety Agency	Standard	Notes & Conditions
CB Report	IEC62368-1: 2014	Audio/Video, Information and Communication Technology Equipment
UL	UL62368-1, CAN/CSA C22.2 No.62368-1-14	
TUV	EN62368-1: 2014/A11: 2017	
CE	Meets all applicable directives	
UKCA	Meets all applicable legislation	

Application Notes

Power OK Signal

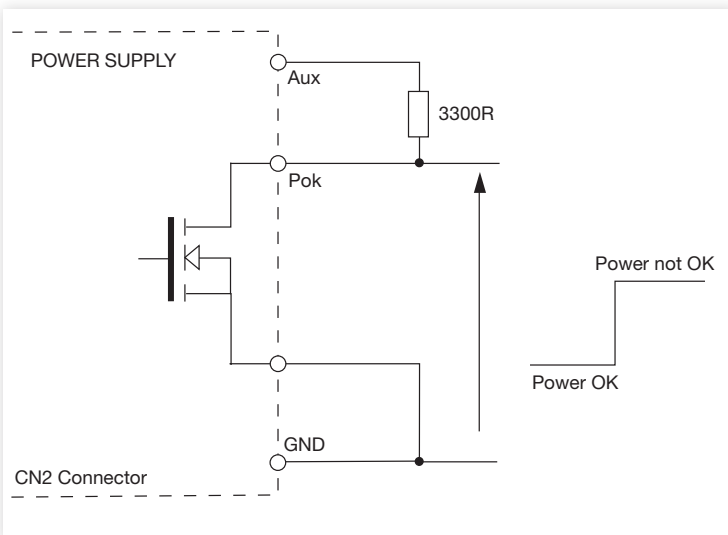

Open drain signal, low when PSU turns on.
Maximum sink current: 20mA Maximum drain voltage: 40V

OVP Settings

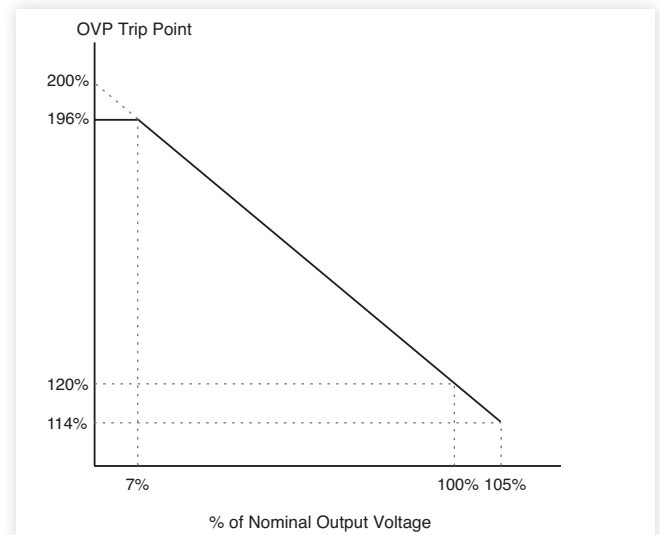

Application Notes

Current Sharing with Remote Sense

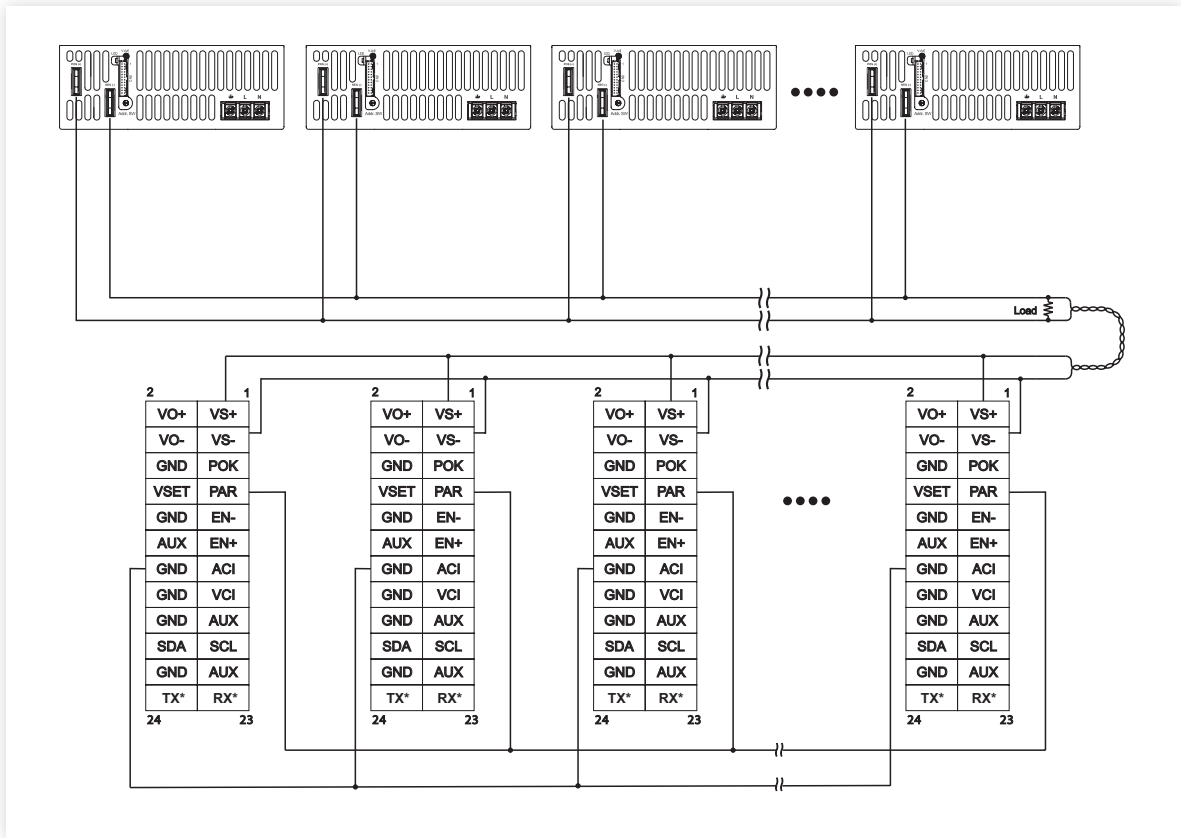

Remote Sense

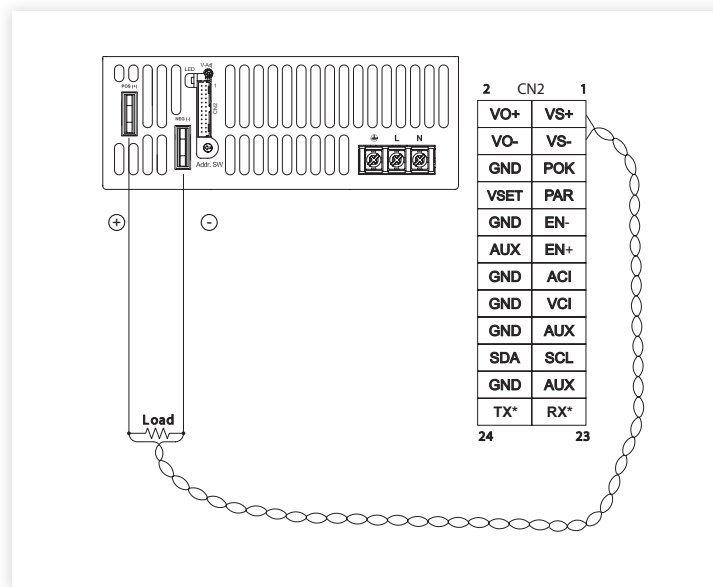

Notes:

In parallel operation, it is possible that only one unit will operate if the load is less than 5% of the combined rated output load. It is possible to have more than five units in parallel, contact sales for details. *Pin 23 and 24, Only usable with driver board "KIT-RS232-X" or "KIT-RS485-1"

Application Notes

Current Sharing with Local Sense

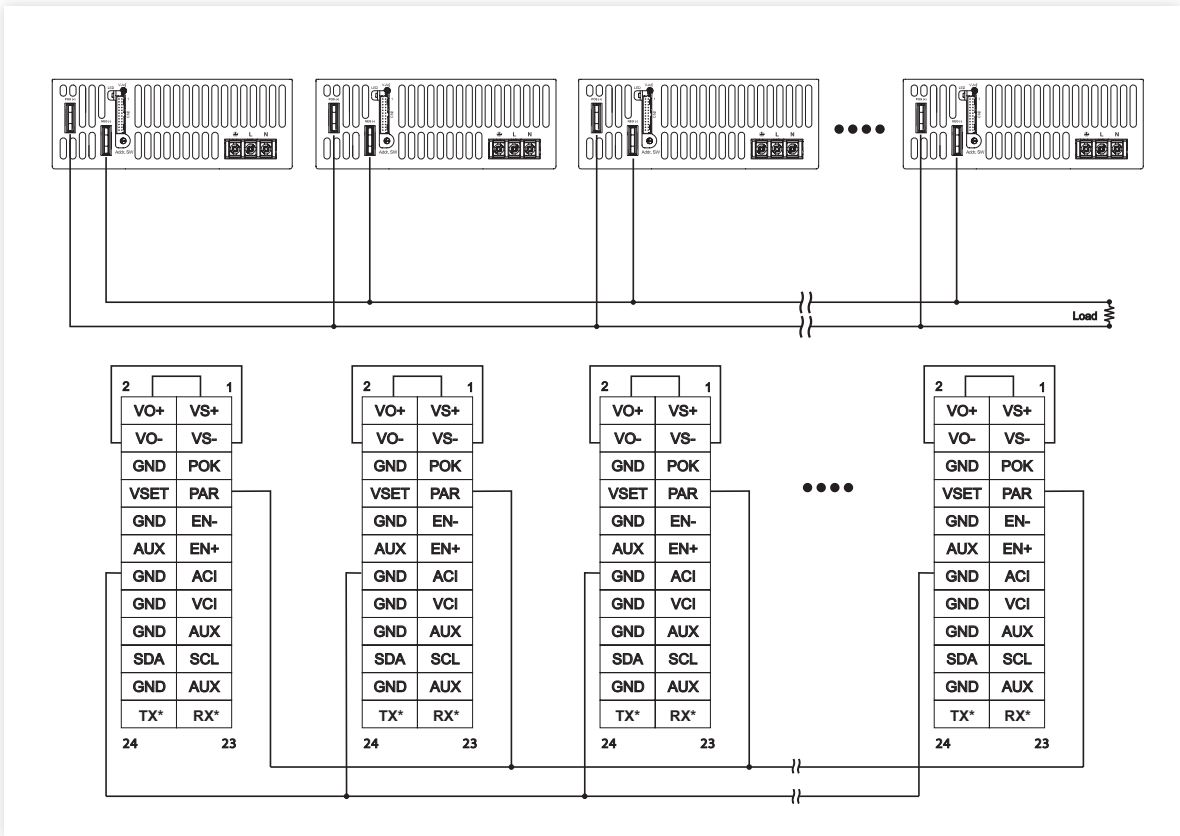

Local Sense

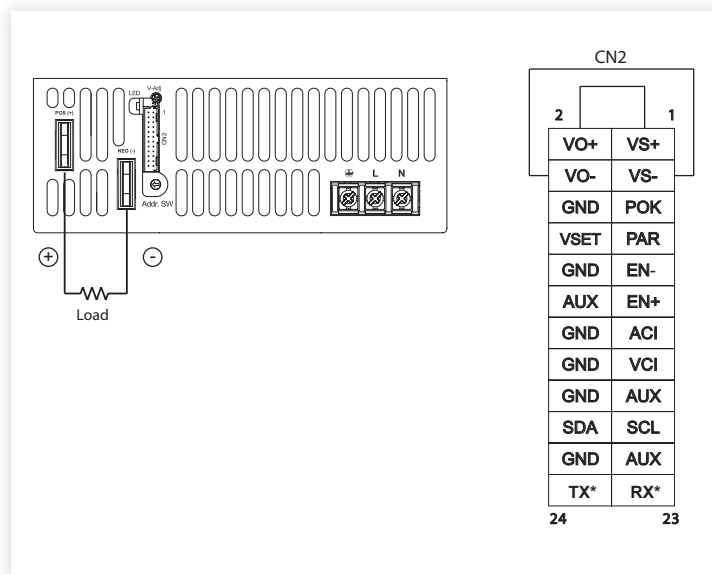

Notes:

In parallel operation, it is possible that only one unit will operate if the load is less than 5% of the combined rated output load. It is possible to have more than five units in parallel, contact sales for details. *Pin 23 and 24, Only usable with driver board "KIT-RS232-X" or "KIT-RS485-1"

Mechanical Details

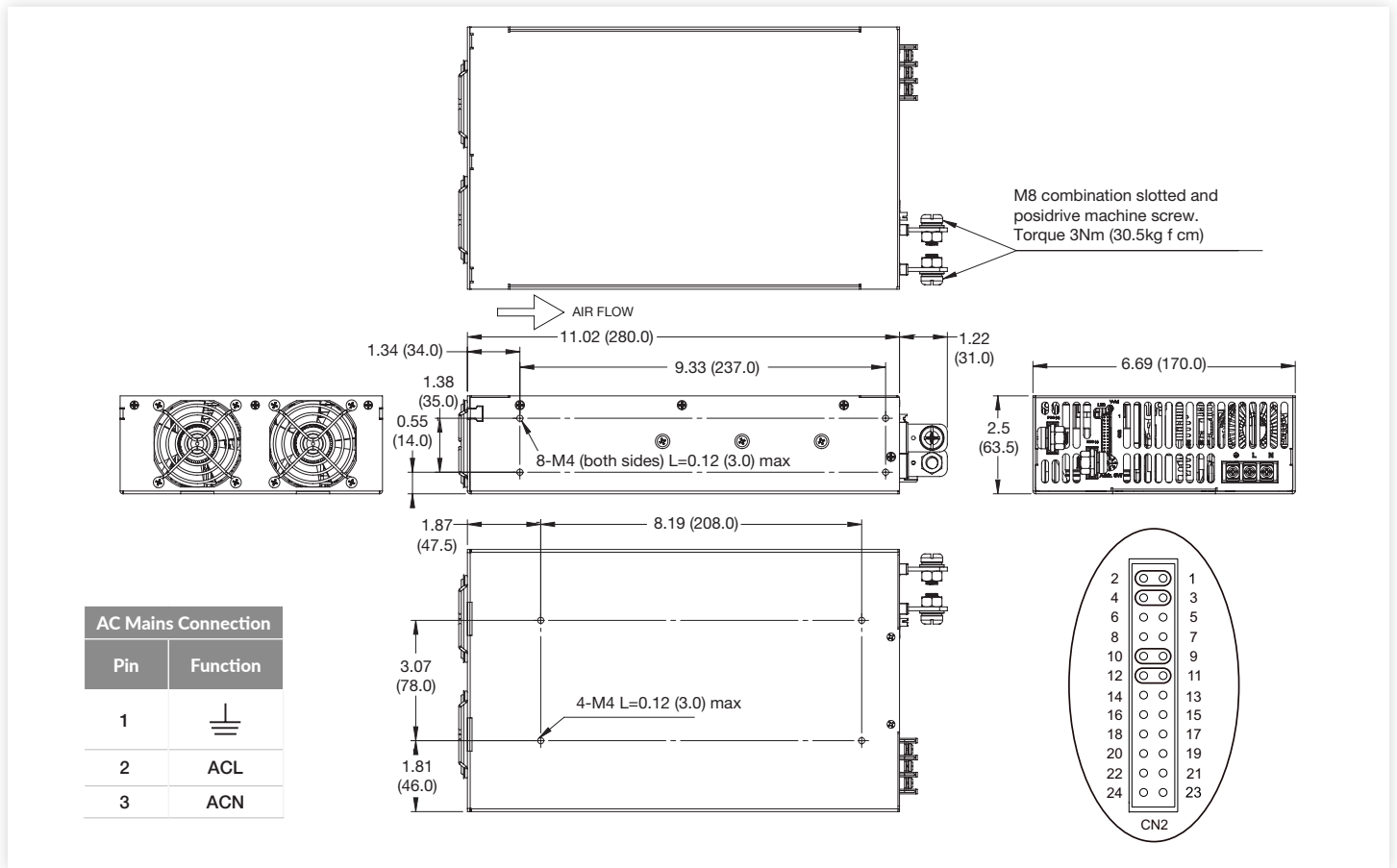

CN2 Control Pin Connections								
Pin	Function	Description	Pin	Function	Description	Pin	Function	Description
1	VS+	Remote sense (+)	9	EN-	Inhibit On/Off(-)	17	AUX	+5V/0.5A or +9V/0.3A Standby power
2	VO+	Positive Output Voltage	10	GND	Ground	18	GND	Ground
3	VS-	Remote Sense (-)	11	EN+	Inhibit On/Off (+)	19	SCL	I ² C Serial Clock
4	VO-	Negative Output Voltage	12	AUX	+5V/0.5A or +9V/0.3A Standby power	20	SDA	I ² C Serial Data
5	POK	Power OK	13	ACI	I Program	21	AUX	+5V/0.5A or +9V/0.3A power
6	GND	Ground	14	GND	Ground	22	GND	Ground
7	PAR	Parallel Operation Current Share	15	VCI	V Program	23	RX ⁽¹⁾	Receive
8	VSET	Aux Output Setting	16	GND	Ground	24	TX ⁽¹⁾	Transmit
								Transmit
								For RS485 Data+ Interface

- Notes:**
1. Only usable with driver board "KIT-RS232-X" or "KIT-RS485-1"
 2. Dimensions shown in inches (mm).
 3. Weight: 7.94lb (3.6kg)
 4. Mating Connector: CN2 JST PHDR-24VS Housing, SPHD-002T-P0.5 Contact
 5. Torque of mounting M4 screw: 1.27Nm (13.0kg f cm)