

MODEL NO.	"A"	Ø"B"
CBBJR79TL	.24	.063
CBBJR79TLA	.34	.070

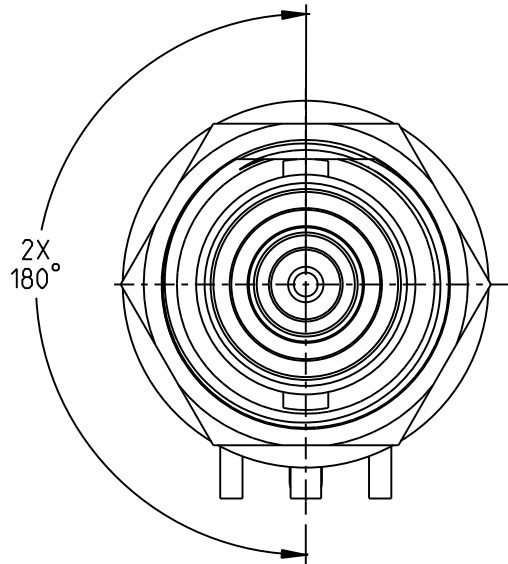

TRB INTERFACE
PER MIL-STD-348
FIGURE 201-2

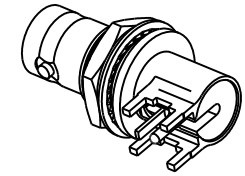
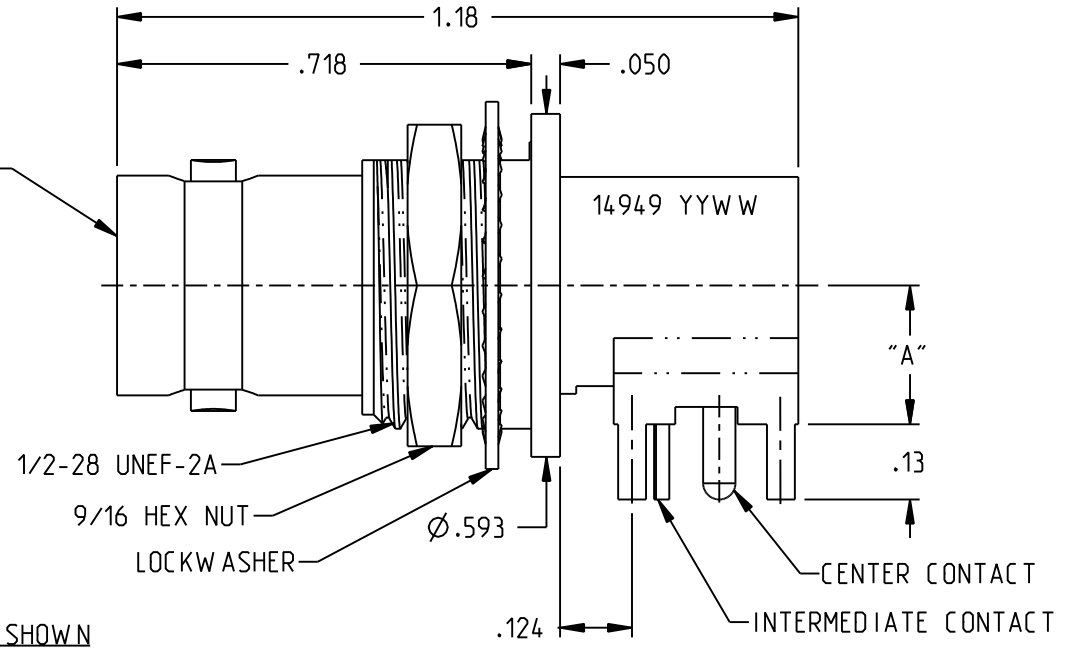

CBBJR79TL SHOWN

NOTES: UNLESS OTHERWISE SPECIFIED

1. MATERIALS AND FINISH:
 - 1.1 BODY: TIN PLATED BRASS
 - 1.2 OUTER INSULATOR: PTFE (TEFLON)
 - 1.3 INTERMEDIATE CONTACT: GOLD PLATED BRASS
 - 1.4 DIELECTRIC: PTFE (TEFLON)
 - 1.5 CENTER CONTACT: GOLD PLATED BERYLLIUM COPPER
 - 1.6 MOUNTING HARDWARE: TIN PLATED COPPER ALLOY
2. ELECTRICAL:
 - 2.1 IMPEDANCE: NON-CONSTANT
 - 2.2 FREQUENCY (MAX): 500MHz
3. PANEL THICKNESS (MAX): .125
4. PANEL NUT TORQUE (MAX): 35 INCH POUNDS

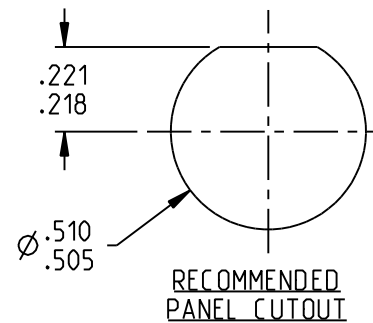

RECOMMENDED
PANEL CUTOUT

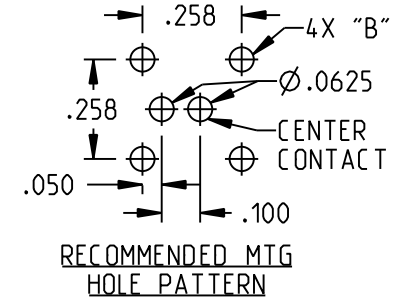

RECOMMENDED MTG
HOLE PATTERN

		TROMPETER	
	RoHS2 <input checked="" type="checkbox"/> 2015/863/EU	Title: TRB RIGHT ANGLE CIRCUIT BOARD JACK	
<small>NOTICE: The information in this drawing is PROPRIETARY and must not be used without the permission of Cinch Connectivity Solutions. It may contain data whose export is restricted. Verify status prior to exporting.</small> <small>INTERPRET DRAWING IN ACCORDANCE WITH ASME Y14.5-2018</small>	<small>UNLESS OTHERWISE SPECIFIED UNITS: INCH</small> .XX ±.02 .XXX ±.005 ANGLES ±2°	Model No. CBBJR79TL/A	Date: 10/18/2021 Sheet 1 OF 1
Size A	DO NOT SCALE DRAWING	Date: 10/18/2021	Sheet 1 OF 1