

REVISIONS					
REV	ECO	DESCRIPTION	DATE	BY	APPR
A1	--	RELEASE NEW DRAWING	15JUL20	VITO	TOMMY
A2	--	REVISE THE VIEWS	1/MAR/23	VITO	TOMMY

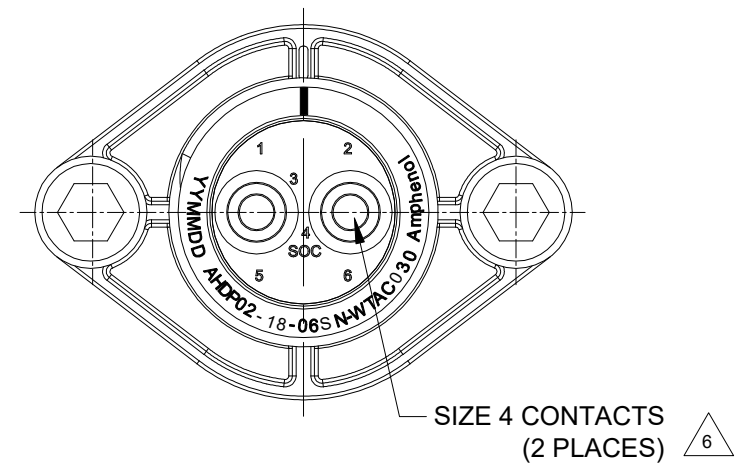
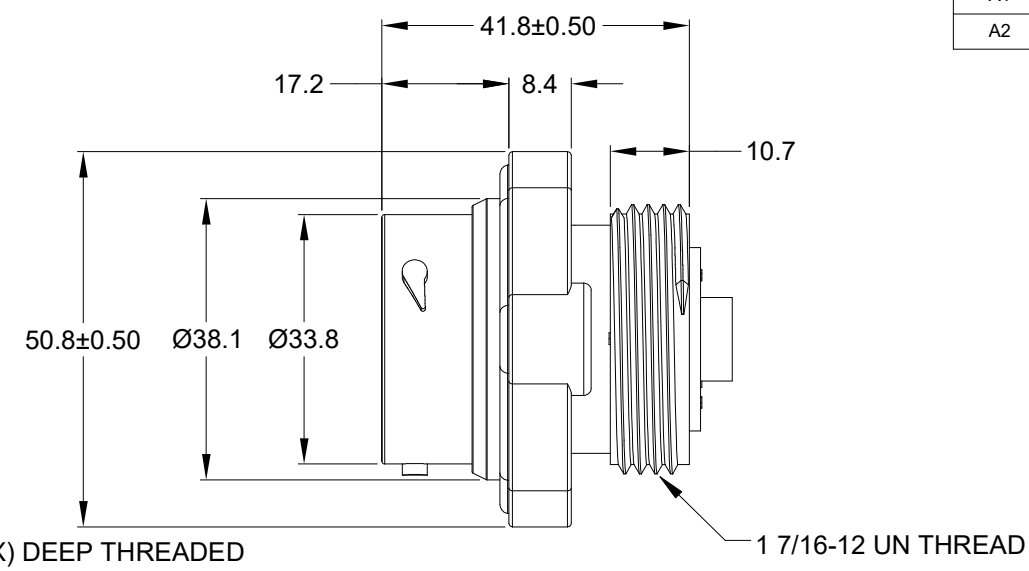
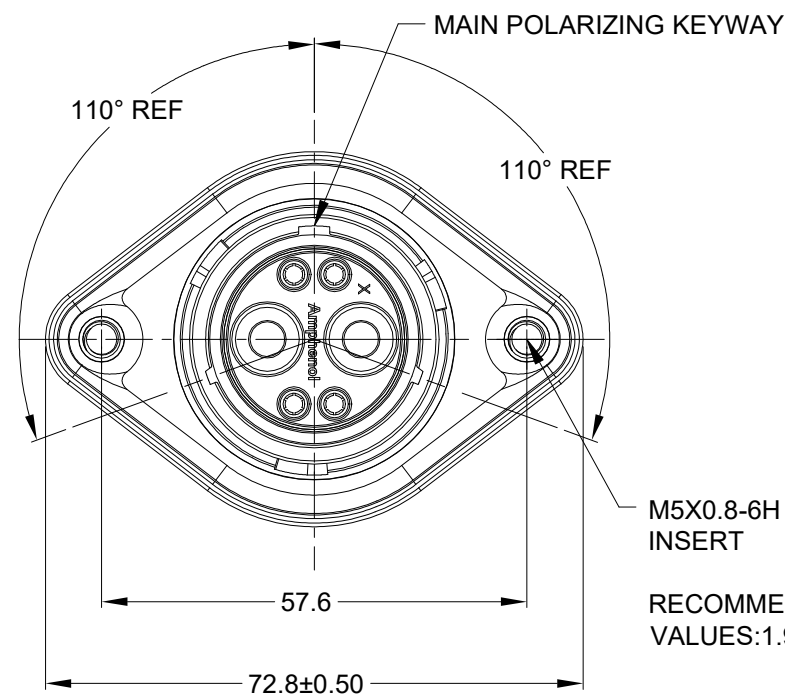

M5X0.8-6H 8mm(2X) DEEP THREADED INSERT
 RECOMMENDED TORQUE VALUES:1.9-2.2 N.m

NOTES: UNLESS OTHERWISE SPECIFIED

- MATERIAL:
 HOUSING: THERMOPLASTIC; BLACK
 SEAL: SILICONE RUBBER
 THREADED INSERT: STAINLESS STEEL
- MODIFICATIONS: WIDE THREAD ADAPTER(WTA);
 STANDARD DIA,WIRE SEAL;
 SEALED PANEL MOUNT;
- SPECIFICATIONS:
 3.1 OPERATING TEMPERATURE: -55°C TO +125°C.
 3.2 DIELECTRIC WITHSTANDING VOLTAGE: LESS THAN 2 MILLIAMPS CURRENT LEAKAGE @ 1500 VOLTS AC.
 3.3 INSULATION RESISTANCE: 1000 MEGOHM MIN @ 25°C.
 3.4 MOISTURE RESISTANCE: IP67&IP69K (MATED CONDITION).
 3.5 MATING CYCLE DURABILITY: 100 CYCLES
 3.6 RoHS COMPLIANT
- MATING PART: AHDP06-18-06P* (* = SEAL TYPE) (C030 OPTION)
- ALL DIMENSIONS ARE FOR REFERENCE USE ONLY.

6 CONTACT SIZE AND WIRE RANGE:

CONTACT SIZE	MIN. INSUL O.D.	MAX. INSUL O.D.	TYPICAL WIRE RANGE	CURRENT RATING
4	6.63 mm (.261in)	7.41mm (.292 in)	6 AWG (16-13mm ²)	100 AMPS

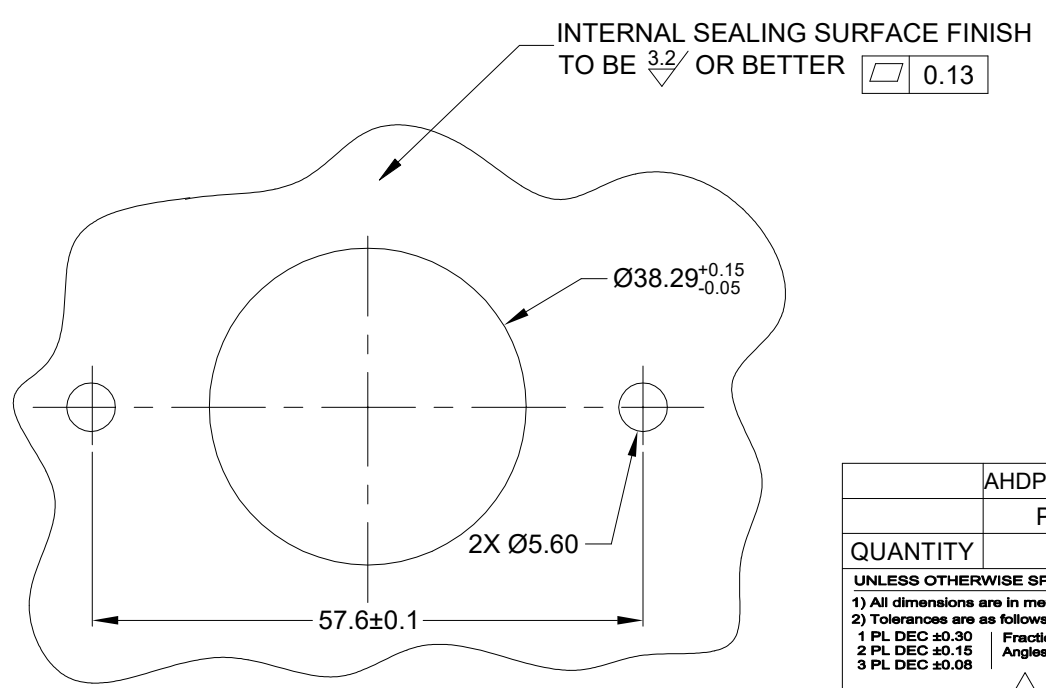

RECOMMENDED PANEL MOUNTING HOLE
 RECOMMENDED PANEL THICKNESS:1.6 TO 4.7MM

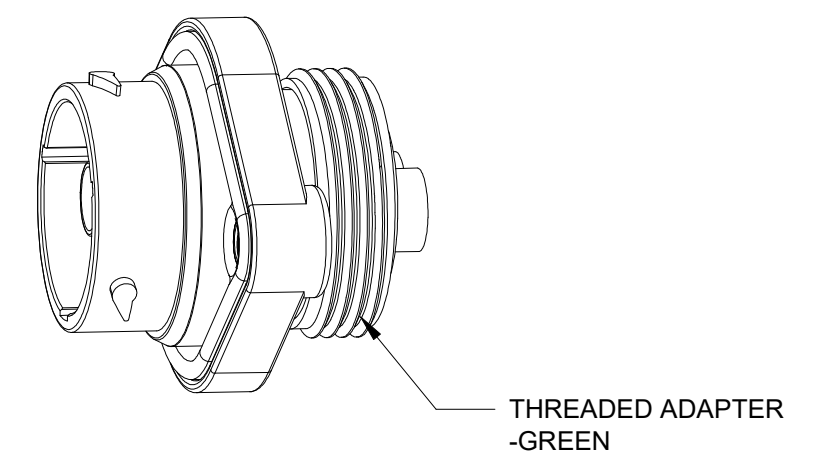

AHDP02-18-06SN-WTAC030		DESCRIPTION		ITEM
PART NUMBER		DESCRIPTION		ITEM
QUANTITY	MATERIALS LIST			
UNLESS OTHERWISE SPECIFIED		SIGNATURES		DATE
1) All dimensions are in metric(mm).		DRAWN: VITO.LI		1/MAR/23
2) Tolerances are as follows:		CHECKED: ORION.LI		2/MAR/23
1 PL DEC ±0.30		ENGINEER:		
2 PL DEC ±0.15		APPROVAL: TOMMY.XIE		3/MAR/23
3 PL DEC ±0.08		CUSTOMER:		
3) Note reference = X		THIS DRAWING IS SUPPLIED FOR INFORMATION ONLY. DESIGN FEATURES, SPECIFICATIONS AND PERFORMANCE DATA SHOWN HEREON ARE THE PROPERTY OF THE AMPHENOL CORPORATION. NO RIGHTS OF REPRODUCTION ARE IMPLIED. ALL DIMENSIONS ARE SUBJECT TO NORMAL MANUFACTURING VARIATIONS.		
MATERIAL SPECIFICATIONS:		SIZE		REVISION
PROCESS SPECIFICATIONS:		B C-		A2
NEXT ASSY:		DWG NO: AHDP02-18-06SN-WTAC030		
		SCALE: NONE		SHEET 1 OF 1

TITLE: 2 POS RECEPTACLE SOCKET, PANELMATE AHDP SIZE 18, NORMAL SEAL, WTA
 DWG NO: AHDP02-18-06SN-WTAC030
 REV: A2
 SH: 1
 OF: 1

A Series™ - Contact Size 4 Options (Works with: ATHD and DuraMate Series)

Machined Contacts, Pins and Sockets					
Part Number	Description	Size	AWG	Type	Amps
AT60-203-04141-4	Male Contact - Pin, Copper Alloy, Nickel-Plated	4	4	Machined	100A
AT60-204-0490	Male Contact - Pin, Copper Alloy, Nickel-Plated	4	6	Machined	100A
AT62-203-04141-4	Female Contact - Socket, Copper Alloy, Nickel-Plated	4	4	Machined	100A
AT62-203-04141	Female Contact - Socket, Copper Alloy, Nickel-Plated	4	6	Machined	100A

Tooling - Machined Contacts	
Part Number	Description
WA23	Heavy Duty Pneumatic Crimp Tool -Uses Universal Positioner Part No. WA23-101DA and Crimp Locator MFX-3961
WA23-138DA	Die Assembly -for Heavy Duty Pneumatic Crimp Tool, Size 4
WA23-11	Contact Locator, Size 4
96-978-22	Crimper and Dies -for Size 10mm ² -185mm ² Wires
AT11-027-0405	Contact Removal Tool, Plastic, Size 4, 4AWG