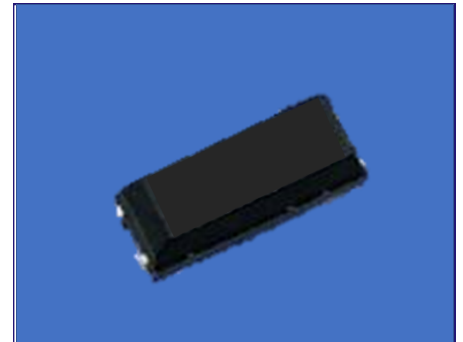

**TUNING FORK CRYSTAL UNIT IN SMD 10.4x4.1mm RESIN MOLD PACKAGE.**
**PRODUCT FEATURES**

- Package dimensions 10.4x4.1x3.6mm with 4 J-leads.
- Reliable resin mold SMD package suitable for SMT.
- Heat resistant mold allowing high temperature reflow.
- Suitable for low power consumption applications.
- RoHS compliant by exemption.

**APPLICATIONS**

- Real time clocks
- Microprocessors
- Timers and controllers
- Meters and handheld devices

**PRODUCT PHOTO (NOT IN SCALE)**

**PRODUCT SPECIFICATIONS**

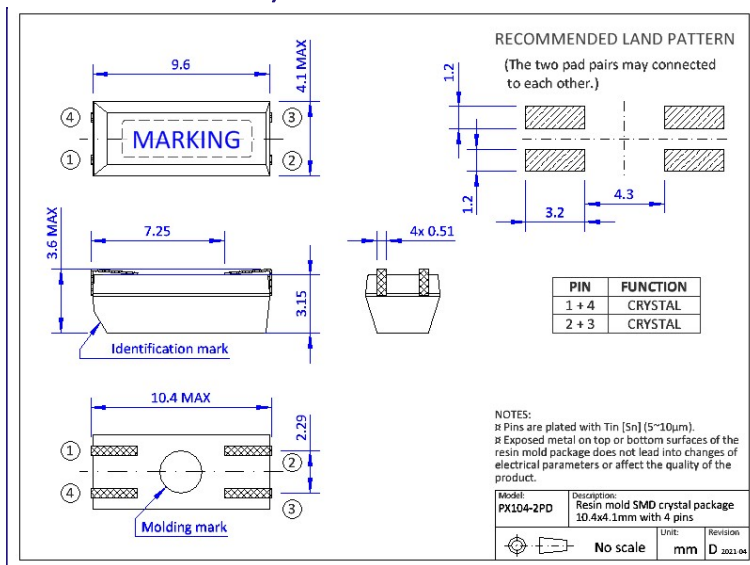
PARAMETER	3610SH		CONDITIONS / REMARKS		
Nominal frequency range	32.768kHz	20 ~ 165kHz	Please contact us for available frequencies.		
Vibration mode	Fundamental				
Frequency tolerance	±20ppm / ±50ppm	±50ppm / ±100ppm	Other options available.		
Stability over temperature	-0.04ppm/°C <sup>2</sup> MAX		Parabolic coefficient.		
Operating temperature range	-20 to +70°C or -40 to +85°C		Other options available.		
Turnover temperature	+25±5°C				
Equivalent series resistance (ESR)	<50kΩ	<60kΩ	20~31.2kHz	<20kΩ	40~130kHz
		<50kΩ	31.2~40kHz	<10kΩ	130~165kHz
Shunt capacitance	1.9pF	0.6~2.0pF	Depending on frequency.		
Motional capacitance	2.7fF	0.6~4.0fF	Depending on frequency.		
Load capacitance	6, 7, 9 or 12.5pF	6~32pF or SERIES	Please specify.		
Drive level	0.5µW TYP / 2.0µW MAX				
Aging per year	±3ppm		At +25°C		

**PACKAGE OUTLINE / DIMENSIONS**

**PACKAGING INFORMATION**

- Tape & Reel compliant to EIA-481.
- Embossed carrier width 16mm.
- Component pitch in carrier 8mm.
- Reel diameter 330mm.
- QTY per reel: 3,000pcs

**RECOMMENDED REFLOW PROFILE**
