



风华高科

广东风华高新科技股份有限公司

FENGHUA

GUANGDONG FENGHUA ADVANCED TECHNOLOGY (HOLDING) CO., LTD.

承 认 书

APPROVAL SHEET

客户名称: _____

CUSTOMER _____

品 名: 金属膜电阻器

PARTNAME _____

规 格: FHMFR-*W***F

SPECIFICATION _____

版 本 号: FH2014-6

VERSION _____

日 期: _____

DATE _____

制 造			客 户*		
APPROVAL			APPROVAL		
拟制	审核 (29)	确认	检验	审核	批准

一. 品名 TYPE NAME

依据其种类，分别标明型号、额定功耗、标称阻值、精度、和形状。

According to the types of power rated, resistor value, tolerance and shapes.

<u>FHMFR</u>	<u>1/4W</u>	<u>2K</u>	<u>± 1%</u>
Type	Wattage	Nominal resistance	tolerance
型号	额定功率	标称阻值	误差

二. 金属膜电阻器结构图 METAL FILM CONSTRUCTION

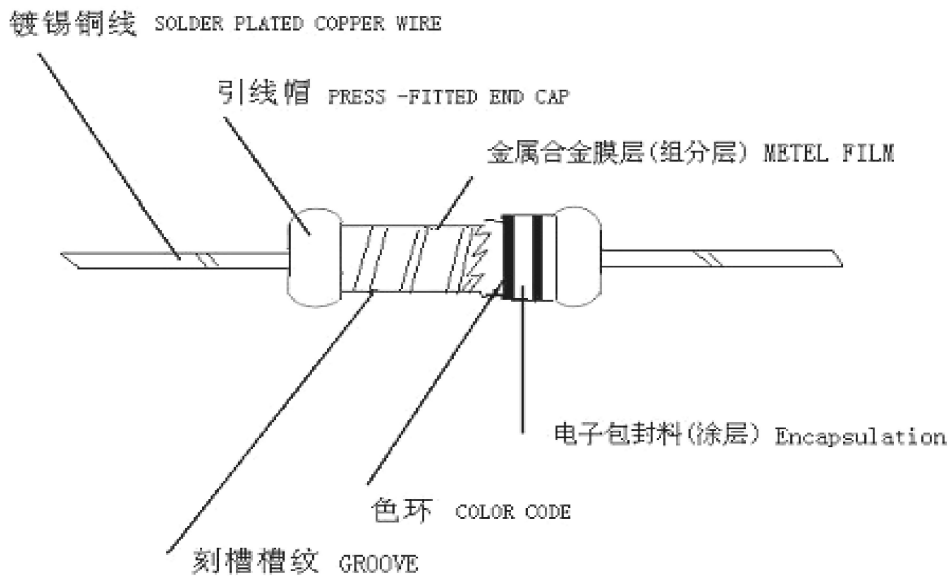

REMARK: 底漆颜色 COATING COLOR: 蓝色 (Blue)

三. 特点 FEATURES

1. 高精度的产品 TOR QUALITY AND HIGH RELIABILITY
2. 低电流噪声 (小于 0.2UV) LOW NOISE (<0.2UV)
3. 低电阻温度系数 (± 50PPM/°C) LOW T.C.R TO ±50PPM/°C
4. 极好的长期稳定性 EXCELLENT LONG TERM STABILITY
5. 标准误差: ± 0.1%, ± 0.25%, ± 0.5%, ± 1%.

STANDARD TOLERANCES: ±0.1%,±0.25%,±0.5%,±1%

6. 环保无铅产品

RoHS COMPLIANT/LEAD-FREE AVAILABLE.

四. 主要技术指标 MAIN SPECIFICATION



型号 Type	最大工作电压 WORKING	最大负荷电压 MAX OVERLOAD	额定功率 Rated Power at 70°C	电阻范围 RESISTANCE VALUE RANGE
MF 1/6W / 1/8W.	200V	400V	1/6W	0.1Ω—10MΩ
MF1/4W / 1/4WS	250V	500V	1/4W	0.1Ω—10MΩ
MF1/2W / 1/2WS	350V	700V	1/2W	0.1Ω—10MΩ
MF1W / 1WS	500V	1000V	1W	0.1Ω—10MΩ
MF2W / 2WS	500V	1000V	2W	0.1Ω—10MΩ
MF3W / 3WS	500V	1000V	3W	0.1Ω—10MΩ
MF5W/ 5WS	500V	1000V	5W	0.1Ω—10MΩ

1. 额定功率 POWER RATING

额定功率的定义为在环境温度 70°C 最大输出功率。当环境温度超过 70°C。

Power rating is defined as maximum power rating continuously applied under ambient temperature at 70°C. when the ambient temperature exceeds 70°C.

FIG.1 DERATING CURVE

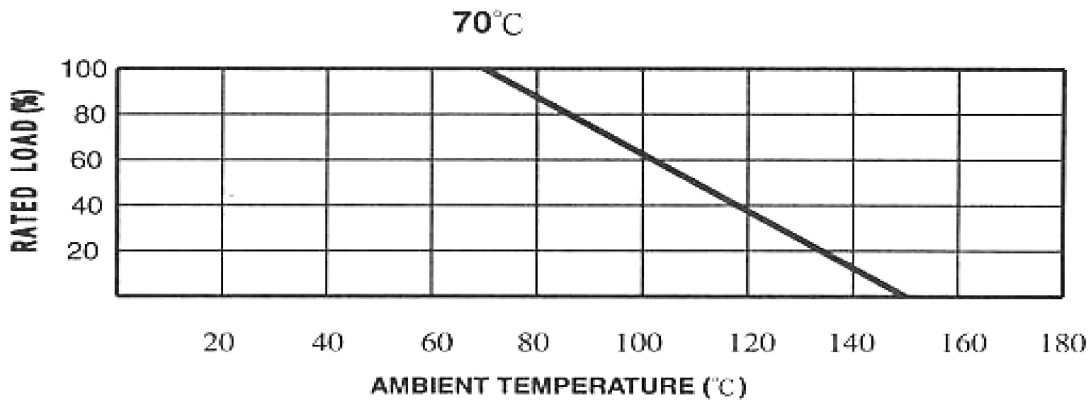

2. 额定电压 RATED VOLTAGE

额定电压为交流或直流电压（频率为 50Hz 或 60Hz）额定电压计算方式为：

Rated voltage is defined as the DC or AC (effective Value at commercial frequency example 50 C/S, 60 C/S), Voltage when rated power is applied and can be calculated By the following:

$$V = \sqrt{P \times R}$$

V = RATED VOLTAGE

P = RATED POWER (WATTS)

R = NOMINAL RESISTANCE VALUE (OHM)

When the calculated rated voltage exceeds the Maximum usable voltage flue shown in CHART, the Maximum usable voltage is defined as the voltage According to the power-decreasing curve shown in CHART.



3. 产品性能 PERFORMANCE

RoHS

项目 ITEM	性能及验收标准 PERFORMANCE AND QUALITY ACCEPTANCE	测试方法 TEST METHOD
温度系数 Resistance to temperature coefficient	1. $10\Omega < R_x < 100K\Omega$ PPM/°C < 50PPM 2. $R_x < 10\Omega$ PPM/°C > 50PPM 3. $100K\Omega > R_x < 10M\Omega$ PPM/°C < 100PPM/°C	$PPM/°C = \frac{R - R_0}{R_0} * \frac{10^6}{T - T_0}$ R = Measured resistance (Ω) at T T °C 电阻实测值 (Ω) Ro = Measured resistance (Ω) at To To °C 电阻实测值 (Ω) T = Measured test temperature(°C) 测试温度的实测值 To = Measured base temperature(°C) 基准温度的实测值
短时负荷 Short time overload	$\pm(0.5\%R + 0.05ohm)$ Shall be no mechanical breakage 无破损 (外观正常)	2.5 倍额定电压 (交流或直流), 5 秒。 AC or DC voltage 2.5times the rated Voltage for 5 seconds .
耐电压 Voltage endurance	No breakdown or flashover 无击穿或飞弧	将电阻放于“V”形槽内, 加 1.42 倍 额定电压, 保持一分钟。 Lay the resistor on the 90° angle metal “V” peak is 1.42 times as much as insulate voltage .
端子强度 Terminal strength	内外部无损伤 Shall be no mechanical breakage	施加 3.5KG 30S 的拉力 Pull test apply 3.5KG force to the lead in the direction of lead axis for 30±5 seconds.
耐焊性 Heat resistively against soldering	$\pm(0.5\%R + 0.05ohm)$ Shall be no mechanical breakage 无破损 (外观正常)	将电阻引出端浸入 350°C ± 10°C 的 锡中, 深度离电阻体 3±0.05mm, 时 间 3.5±0.5 秒。放置一小时再测试。 Dip the lead in to a solder bath having a temperature of 350°C ± 10 °C up to 3±0.05mm from the body of the resistor and hold it for 3.5 ± 0.5seconds leave the resistor ,at room temperature 1 hours after ,then Measure.



RoHS

项目 ITEM	性能及验收标准 PERFORMANCE AND QUALITY ACCEPTANCE	测试方法 TEST METHOD
寿命试验 Load life test	$\pm(1\%R + 0.5\text{ohm})$ Shall be no mechanical breakage 无破损（外观正常）	在 70℃ 的环境中施加额定电压，1 小时通，0.5 小时断 1000 小时。 In the constant temperature chamber 70℃ ,apply rated voltage for 1 hour and shut voltage for 0.5 hour and repeat this cycle for 1000 hours,
上锡效果 Solder ability	$\geq 95\%$	浸入 260℃±5℃ 的锡槽中， 时间 5± 0.5 秒。 Dip the lead in to a solder bath having a temperature of 260℃±5℃ . Time:5± 0.5seconds.
湿度负荷试验 Humidity load test	$\leq \pm (2\% R+ 0.1\text{ohm})$ Shall be no mechanical breakage 无破损（外观正常）	温度在 40℃ ± 2℃，相对湿度 90 - 95 % 室内，用额定电压 1.5 小时开和关闭电压 0.5 小时，重复这个周期 1000 小时，离开 1 小时后在室温下测试。 In temperature chamber 40℃±2℃ , relative humidity 90 - 95%,Apply rated voltage 1.5hour and shut voltage 0.5 hour repeat this cycle for 1000 hours, leave in room temperature for 1 hour after test,
耐振性 Vibration	Shall be no mechanical breakage 无破损（外观正常）	设置振动频率在 10HZ - 55HZ 10HZ/秒 1.5mm 的幅度, 在 1 分钟更换频率的。振动三个方向, 在 3 小时内完成。 set a resistor at the vibration table and vibrate 10HZ—55HZ 10HZ/s. with 1.5mm amplitude in 1 min. when the change of frequency shall be completed uniformly. the vibration shall apply to 3 directions,vertical and horizontal to the axis of resistor each for 3h.
上限类别温度耐久性 Endurance at upper-limit temperature	$\leq \pm (2\%R+0.1 \Omega)$	在 125℃ 温度下，持续时间 1000H At 125 °C temperature, duration of 1000h



五. 标示 Marking

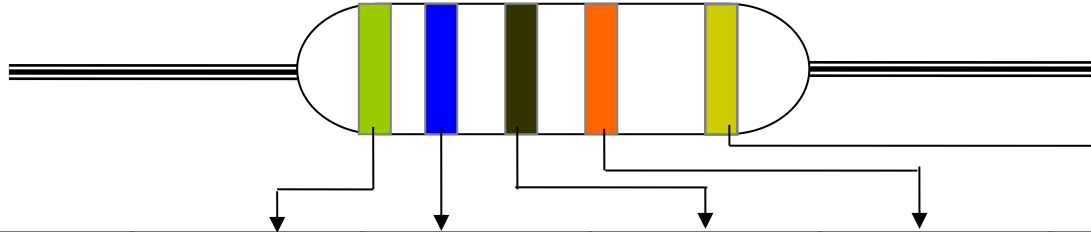

Color	1 st Band	2 nd Band	3 rd Band	4 th Band	Tolerance
Black 黑	0	0	0	10^0	
Brown 棕	1	1	1	10^1	±1% (F)
Red 红	2	2	2	10^2	±2% (G)
Orange 橙	3	3	3	10^3	
Yellow 黄	4	4	4	10^4	
Green 绿	5	5	5	10^5	±0.5% (D)
Blue 蓝	6	6	6	10^6	±0.25% (C)
Violet 紫	7	7	7	10^7	±0.1% (B)
Grey 灰	8	8	8	10^8	±0.05% (A)
White 白	9	9	9	10^9	
Gold 金				10^{-1}	±5% (J)
Silver 银				10^{-2}	±10% (K)

六. B 型尺寸 Dimension (B)

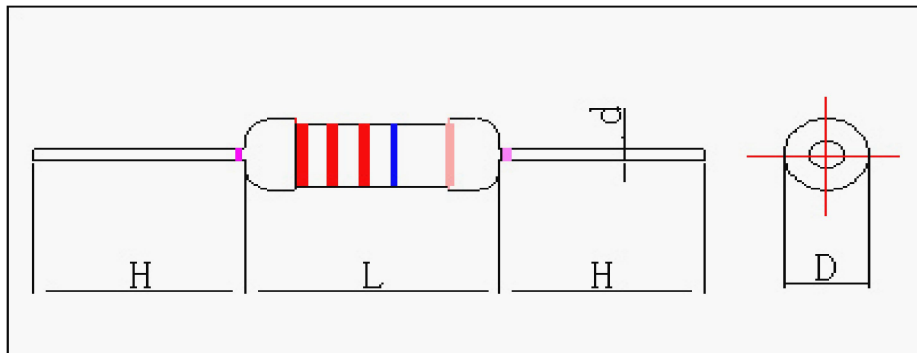

Unit: m/m

TYPE	L	D	H	d ±0.02m	PULLING(Kg)
1/6W 1/8W 1/4WS	3.2±0.3	1.8±0.3	28±2.0	0.40±0.05	2.5Kg-30S
1/4W / 1/2WS	6.0±0.5	2.3±0.3	27±2.0	0.47±0.05	2.5Kg-30S
1/2W / 1WS	9.0±1.0	3.5±0.5	26±2.0	0.50±0.05	2.5Kg-30S
1W / 2WS	11.0±1.0	4.5±0.5	23.5±2.0	0.60±0.05	3Kg-30S
2W / 3WS	15.0±1.0	5.0±0.5	26.5±2.0	0.65±0.05	5Kg-30S
3W /5WS	17.0±1.0	6.0±0.5	25.5±2.0	0.70±0.05	5Kg-30S
5W	24.0±1.0	8.0±1.0	28±2.0	0.75±0.05	5Kg-30S

七. 编带尺寸 Taping Dimension (TB)

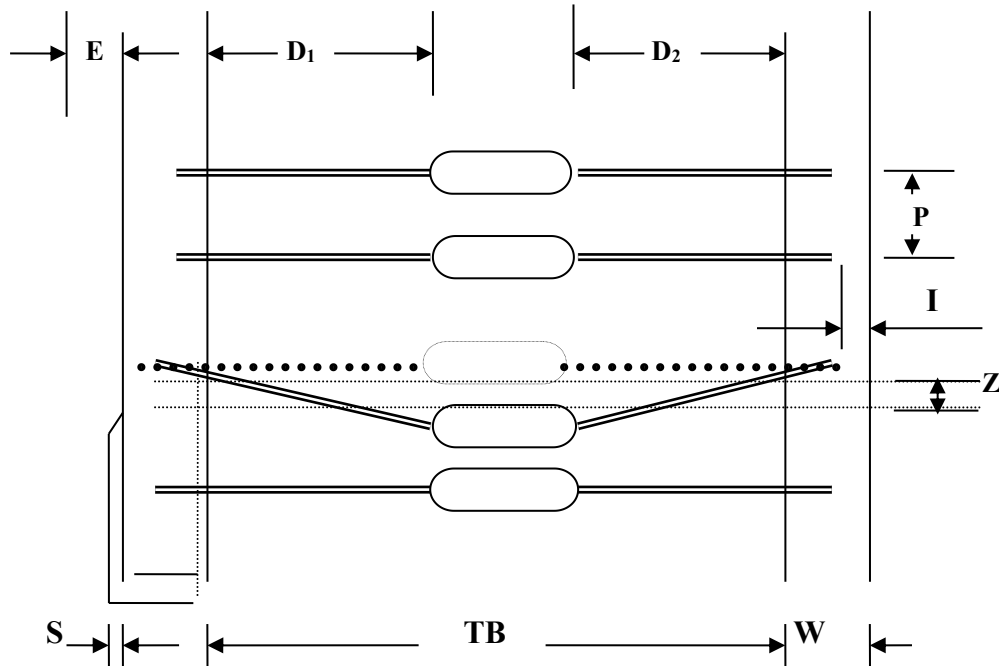

Unit: m/m

WATTS	Type	TB	P±0.5	W±0.5	(D1-D2) MAX	E MAX	Z MAX	S MAX	(I) MAX
1/6W / 1/8W 1/4WS	T52	52±1.5	5	6	0.8	0	1.2	0.8	3.2
1/4W / 1/2WS	T26	26±1.5	5	6	0.8	0	1.2	0.8	3.2
	T52	52±1.5	5	6	0.8	0	1.2	0.8	3.2
1/2W / 1WS	T52	52±1.5	5	6	0.8	0	1.2	0.8	3.2
1W / 2WS	T52	52±1.5	5	6	0.8	0	1.4	0.8	3.2
	T63	63±1.5	5	6	0.8	0	1.4	0.8	3.2
2W / 3WS	T63	63±1.5	5	6	0.8	0	1.4	0.8	3.2
	T73	73±1.5	5	6	0.8	0	1.4	0.8	3.2
3W / 5WS	T73	73±1.5	10	6	0.8	0	1.4	0.8	3.2
5W	T73	73±1.5	10	6	0.8	0	1.4	0.8	3.2

八. 成型尺寸 FORMED DIMENSIONS

1. M - TYPE

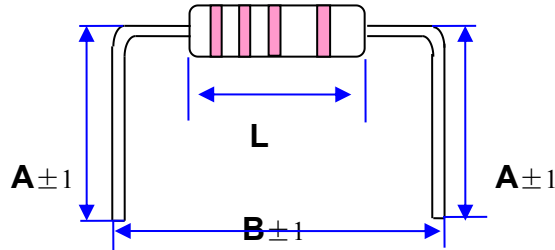

DIMENSIONS 尺寸表示方法：“A × B × A”

WATTS	DIMENSIONS(mm)		
	L	B±1	A±1
1/6W/1/8W/1/4WS	3.3±0.3	6	6
1/4W / 1/2WS	6.0±0.3	10	10
1/2W / 1WS	9.0±0.5	13	10
1W / 2WS	11.0±1.0	15	13
2W / 3WS	15.0±1.0	20	15
3W / 5WS	17.0±1.0	23	15
5W	24.0±1.0	33	15

Remark: A、B 尺寸客户可要求而定.

A, B size customers may request.

2. F - TYPE

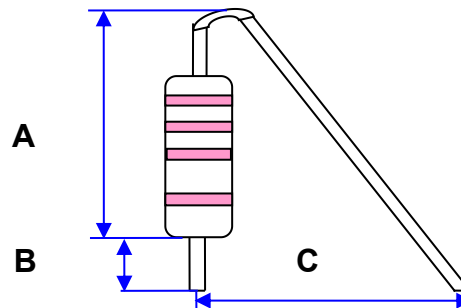

DIMENSIONS: “A × B × C”

WATTS	DIMENSIONS(mm)		
	A	B±2	C±2
1/4W / 1/2WS	9±0.5	5	10
1/2W / 1WS	13±0.5	5	12
1W / 2WS	16±1	5	15
2W / 3WS	20±1	5	17
3W / 5WS	24±1	5	20

Remark: A、B、C 尺寸客户可要求而定.

A, B 、Csize customers may request.



3. MK - TYPE

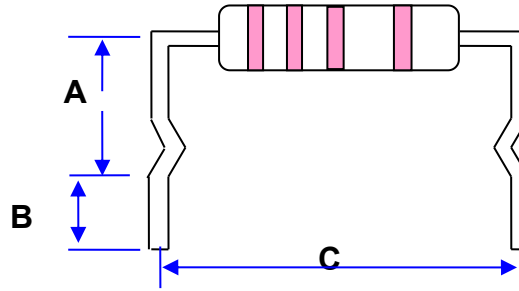

DIMENSIONS: " A × B × C "

WATTS	DIMENSIONS(mm)		
	A±1	B±1	C±1
1/2W / 1WS	10	5	15
1W / 2WS	10	5	15
2W / 3WS	10	5	20
3W / 5WS	10	5	23
5W	13	5	27

Remark: A、B、C 尺寸客户可要求而定.

A, B、Csize customers may request.

4. MB - TYPE

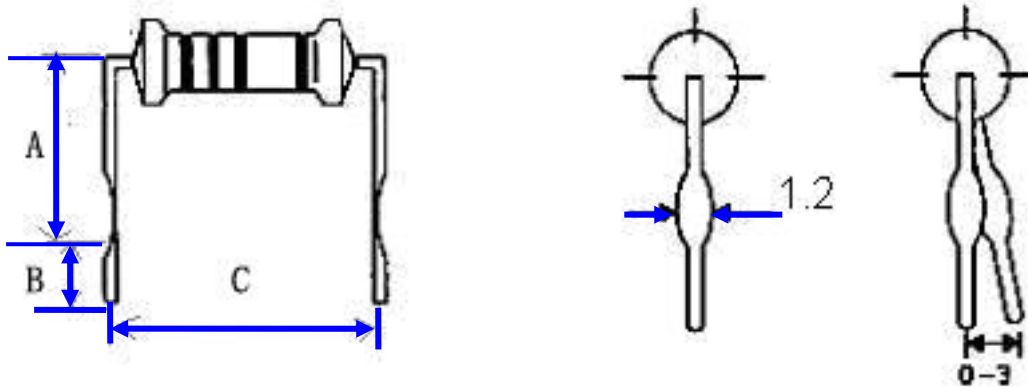

DIMENSIONS: " A × B × C "

WATTS	DIMENSIONS(mm)		
	A±1	B±1	C±1
1/2W / 1WS	10	5	15
1W / 2WS	10	5	15
2W / 3WS	10	5	20
3W / 5WS	10	5	23
5W	13	5	27

Remark: A、B、C 尺寸客户可要求而定.

A、B、Csize customers may request.

九. 包装 PACKING

1. 标签规格 LABEL SPECIFICATION

- 1). 型号及功率 TYPE、WATTS
- 2). 电阻值和误差 RESISTOR VALUE AND TOLERANCE
- 3). 数量 QUANTITY
- 4). 生产批号 LOT NO.

2. 包装数量 Packing quantity

Unit: BOX / Kpcs

TYPE QTY	1/8W	1/4W	1/2W	1W	2W	3W	5W
T26	5	5	NA	NA	NA	NA	NA
T52	5	5	2.5	1	NA	NA	NA
T63	NA	NA	NA	1	1	0.5	0.25
T73	NA	NA	NA	1	1	0.5	0.25
B	20	10	5	4	3	2	1
F	20	10	5	4	3	2	1
M	20	10	5	4	3	2	1
MB	NA	NA	NA	4	3	2	1
MK	NA	NA	NA	4	3	2	1