

RoHS 2.0

PART NO:  
09.01.03.XXX

- 004: GRAY 537C
- 007: BLACK
- 013: GREEN

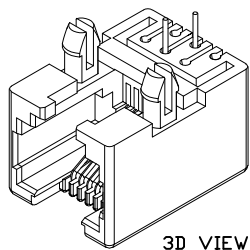

3D VIEW

REV.	ECN	NO.	DESCRIPTION	DATE	DESIGN
A1.	/	.	新增物料编码	20.03.27	Yang
A2.	/	.	重新核对图面	21.01.06	LiHui
A3.	/	.	HD	22.08.15	LZR

NOTES:

1. MATERIAL:
  - 1.1. HOUSING: PBT ,COLOR IS GRAY 537C UL94-V0;
  - 1.2. CONTACT: PHOSPHOR BRONZE,  $\phi 0.46 \pm 0.02$ mm;
2. FINISH: PLATED GOLD OVER NI;
3. RECINNEBDED PCB THICKNESS: 1.60mm;
4. ELECTRICAL:
  - 4.1. VOLTAGE RATING: 125 VAC RMS;
  - 4.2. CURRENT RATING: 1.5 AMP;
  - 4.3. CONTACT RESISTANCE: 35MILLIOHMS MAX.;
  - 4.4. WITHSTAND VOLTAGE: 1000 VAC RMS 50(60)Hz,1MIN.;
  - 4.5. INSULATION RESISTANCE: 1000MEG OHMS MIN @500V DC;
5. MECHANICAL:
  - 5.1. MATING/UNMATING FORCE: 22N MAX.;
  - 5.2. RETENTION STRENGTH: 50N MIN.;
  - 5.3. OPERATING LIFE: 750 CYCLES MIN.;
6. SALT SPRAY TEST: 12H;
7. SOLDERABILITY:  $245 \pm 5^{\circ}\text{C}, 5 \pm 0.5\text{S}$ ;
8. RESISTANCE TO SOLDER:  $260 \pm 5^{\circ}\text{C}, 10 \pm 1\text{S}$ ;
- 9 ENVIRONMENTAL:
  - 9.1. STORAGE TEMPERATURE RANGE:  $-40^{\circ}\text{C} \sim +85^{\circ}\text{C}$ ;
  - 9.2. OPERATION TEMPERATURE RANGE:  $-25^{\circ}\text{C} \sim +70^{\circ}\text{C}$ ;
10. MATES WITH: MODULAR PLUGS THAT CONFORM TO FCC REGULATION PART 68.500;
11. THE MARK WITH "\*" IS THE KEY INSPECTION DIMENSION FOR QC.

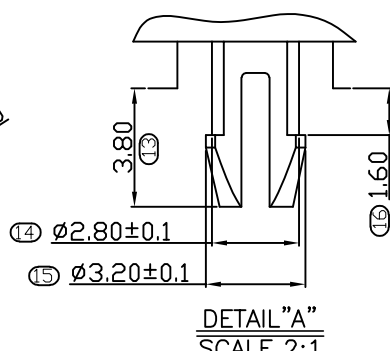
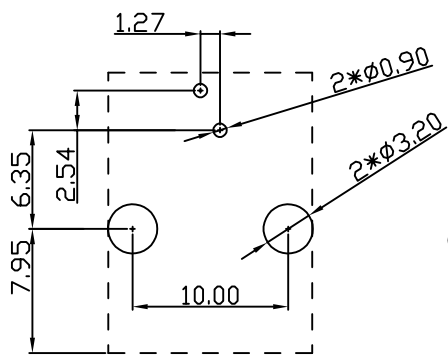
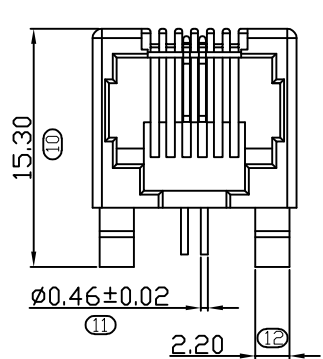
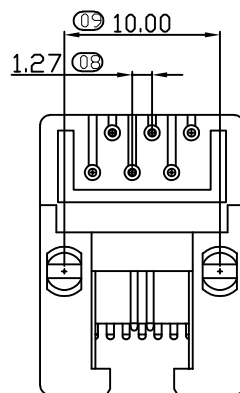
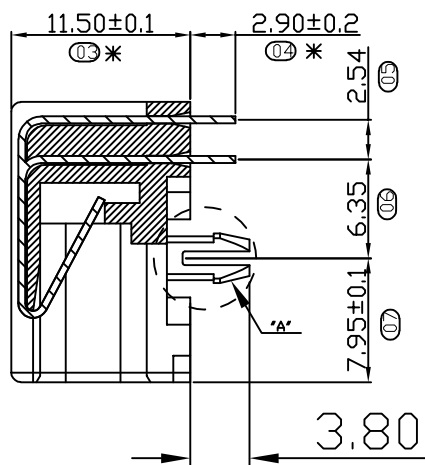
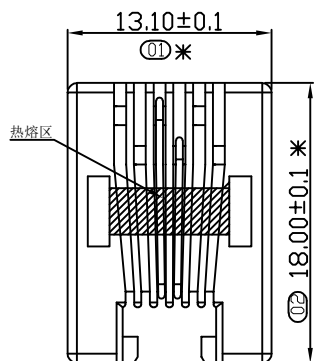

DETAIL "A"  
SCALE 2:1

RECOMMENDED PCB LAYOUT  
TOP VIEW(TOL:±0.05)

B	端子	磷铜	镀镍 镀金(G/F)	
A	基座	PBT	灰色	
序号	品名	材质	电镀/颜色	备注

# 深圳市虹成电子有限公司

UNLESS OTHERWISE SPECIFIED, GENERAL TOLERANCE: X.xxx ±0.10 X.xx ±0.20 X.x ±0.30	NAME: <b>大RJ11 6P2C</b>	P/N: HC-WK62-H18-G			
	DWG NO.:				
ANGULAR: X.xx' ±1' X.x' ±3' X.' ±5'	THIRD ANGLE PROJECTION	UNIT: mm	SCALE: 1:1	SIZE: A4	SHEET: 1/1
	DRAWN:	CHECKED:		APPROVED	