

REV.	ECN.NO.	APPD.
B	/	YS
C	/	WZ
A2	/	LJF

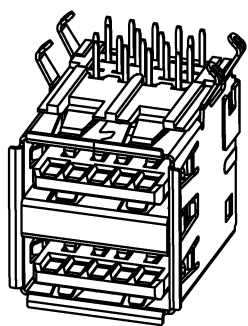

- Remark:
- MATERIAL:
 - Housing:thermoplastic plastics.
 - terminals:Copper Alloy
 - Front Shell:Copper Alloy/SPCC.
Middle Shell:SPCC
 - characteristics:
 - Rating Voltage : 30V AC.
 - Rating Current:PIN1&PIN4(Vbus&Correponding ground PIN)
1.8A MAX Other PINS 0.25A min.
 - Contact Resistance:PIN1&PIN4:30 mΩ MAX. Other PINS: 50 mΩ
 - Insulation Resistance:100 MΩ MIN.
 - Withstanding Voltage:AC 100V between adjacent contacts
 - MECHANICAL CHARACTERISTIC:
 - INSERTION FORCE:35N MAX
 - EXTRACTION FORCE(INITIAL) : 10N MIN
 - EXTRACTION FORCE(AFTER TEST) :8N MIN
 - The lifting weight of the product before durability is 10N Min. 3s
 - Life test:1500Cycles MIN.
 - Temperature Range: -30℃~+80℃.

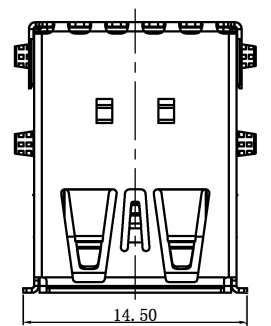
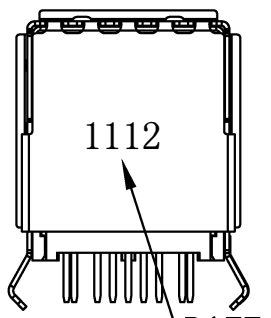
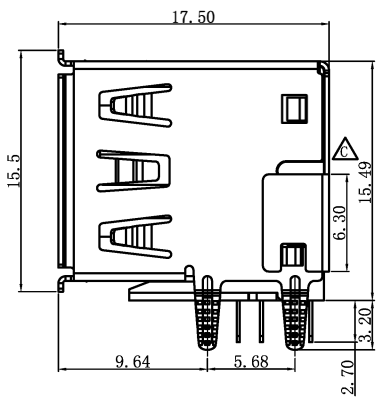
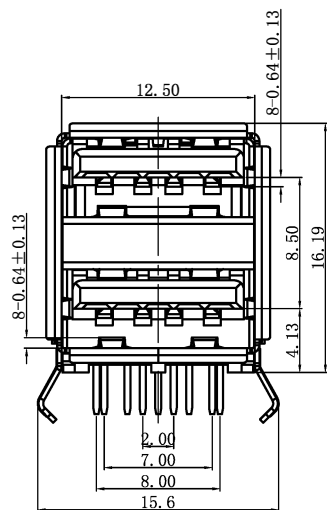

DATE
1112
表示12月
表示2011年

- U321-092X-XXXXXX
- 1:Iron alloy
 - Ni plating
 - 5:Copper alloy
 - Ni plating
 - 1:RoHS UL94V-0
 - R:RoHS
 - 1:tray
 - 2:Tube
 - 8:Tape&Reel
 - 0:Salt Spray 12H
 - 2:Salt Spray 24H
 - 1:Black
 - 7:Blue 300C
 - 8:Blue 300C-1
 - A:Blue 300C-2
 - E:Blue 300C-3
 - 2:PBT
 - 6:LCP

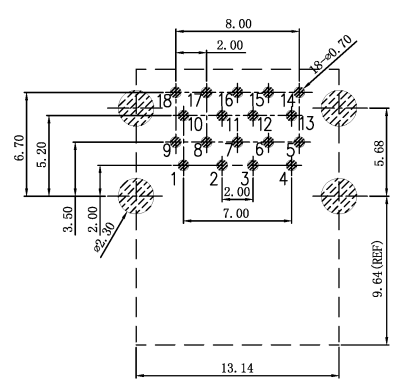

PCB LAYOUT REFERENCE

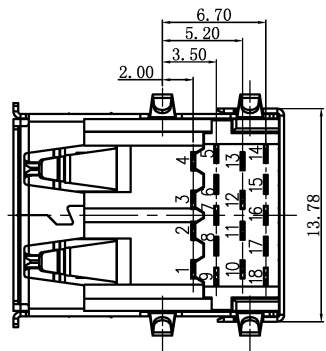

Pin Number	Signal Name	Pin Number	Signal Name	TOLERANCE UNLESS OTHERWISE SPECIFIED	
1	VBUS	10	VBUS	.XXX ±0.10	.X ±3 .XX ±2
2	D-	11	D-	.XX ±0.25	
3	D+	12	D+	.X ±0.35	
4	GND	13	GND	APPROVED	
5	StdA_SSRX-	14	StdA_SSRX-		
6	StdA_SSRX+	15	StdA_SSRX+	CHECKED	
7	GND_DRAIN	16	GND_DRAIN		
8	StdA_SSTX-	17	StdA_SSTX-	DRAWED	Lijinfeng
9	StdA_SSTX+	18	StdA_SSTX+	DATE	2021.04.22
Shell	Shield				

深圳市虹成电子有限公司

USB 3.0 AF双层90度短体(带周期)	
PART No:	HC-USB3.0-L175-2X1-J
PROJECTION:	UNIT: mm
SCALE:	1:1
SHEET:	1 OF 1
REV.:	A2