

RoHS 2.0

REV.	ECN NO.	DESCRIPTION	DATE	DESIGN
A1.	/.	重新核对图面	21.01.14	LiHui
		HD	22.06.02	LZR

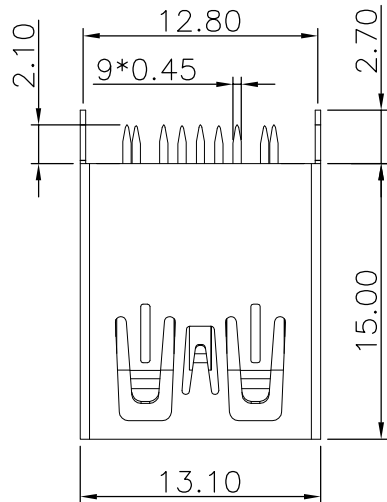

PIN NUMBER	SIGNAL NAME
PIN 1	Vbus
PIN 2	D-
PIN 3	D+
PIN 4	GND
PIN 5	Std_A_SSRX-
PIN 6	Std_A_SSRX+
PIN 7	GND_DRAIN
PIN 8	Std_A_SSTX-
PIN 9	Std_A_SSTX+
SHELL	GND

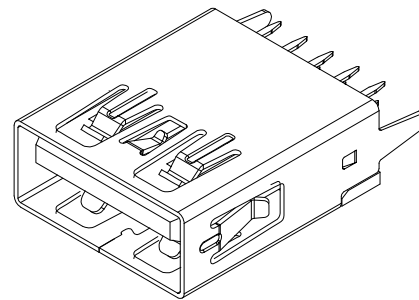

3D VIEW

NOTES:

- MATERIAL:
  - HOUSING: LCP ,COLOR IS BLUE;
  - CONTACT: BRASS(H65 T=0.20&0.25mm);
  - SHELL: COLD ROLLED IRON(SPCC T=0.30mm);
- ELECTRICAL:
  - VOLTAGE RATING: 30V DC ;
  - CURRENT RATING: 1.5A ;
  - CONTACT RESISTANCE: 30MILLIOHMS MAX.;
  - WITHSTAND VOLTAGE: 100V AC RMS 50(60)Hz,1MIN.;
  - INSULATION RESISTANCE: 100MEGOHMS MIN @500V DC;
- MECHANICAL:
  - MATING FORCE: 35N MAX.;
  - UNMATING FORCE: 5~35N ;
  - OPERATING LIFE: 1500 CYCLES MIN.;
- PLATING:
  - TERMINAL:
    - NI PLATING OVER ALL,
    - Tin PLATING ON SOLDER AREA,
    - Au G/Fu" ON CONTACT AREA;
  - SHELL: NI PLATING OVER ALL;
- ENVIRONMENTAL:
  - STORAGE TEMPERATURE RANGE: -40°C~+85°C;
  - OPERATION TEMPERATURE RANGE: -25°C~+70°C;
- SALT SPRAY TEST:24H(Excluding riveted bends)

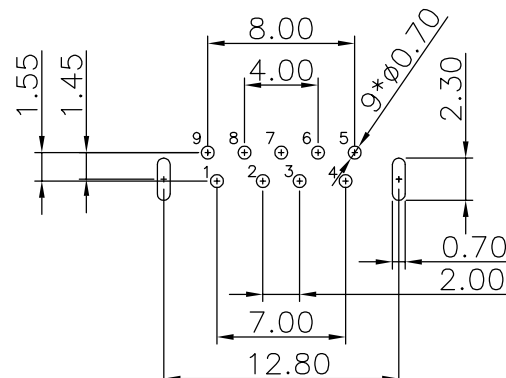
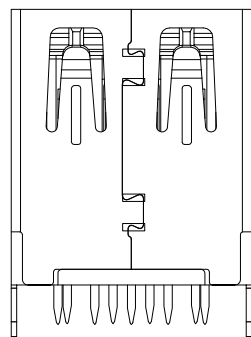
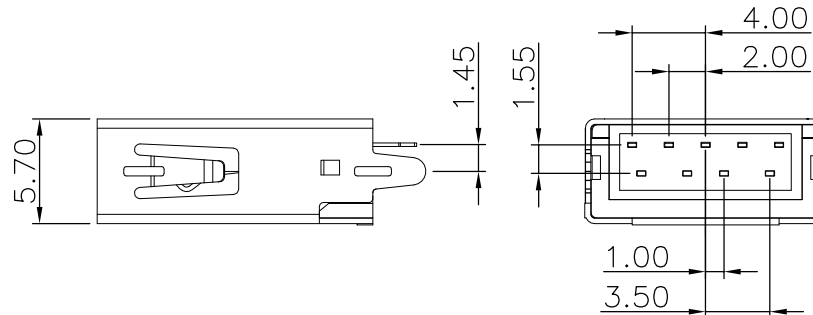
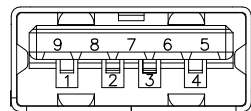

RECOMMENDER P.C.B.LAYOUT TOP VIEW  
(COMPONENT SIDE TOLERANCE±0.05)

C	外壳	SPCC	镀镍	
B	端子	黄铜H65	焊料区镀锡 接触区镀金(1u)	
A	基座	LCP	蓝色	
序号	品名	材质	电镀/颜色	备注

## 深圳市虹成电子有限公司

UNLESS OTHERWISE,  
GENERAL TOLERANCE:

X.xxx ±0.10  
X.xx ±0.20  
X.x ±0.30

ANGULAR:

X.xx° ±1°  
X.x° ±3°  
X.° ±5°

NAME:

3.0 A母180° L15.0平口直脚

P/N:

HC-USB3.0-L150-ZP

DWG NO:

THIRD ANGLE PROJECTION

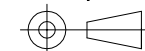

DRAWN:

UNIT:

MM

SCALE

1:1

SIZE:

A4

SHEET:

1/1

REV.

A1

CHECKED:

APPROVED: