

RoHS 2.0

REV.	ECN NO.	DESCRIPTION	DATE	DESIGN
A1.	/.	重新核对图面	21.01.07	LiHui
		HD	22.06.29	LZR

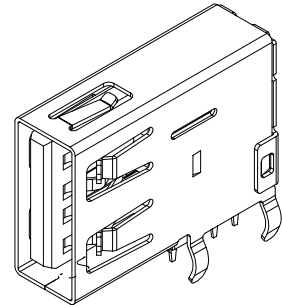

3D VIEW

NOTES:

- MATERIAL:
 - HOUSING: PBT ,COLOR IS WHITE;
 - CONTACT: BRASS,T=0.20±0.02mm;
 - SHELL: SPCC,T=0.3±0.02mm;
- FINISH:
 - TERMINAL:
CONTACT AREA: GOLD PLATED G/Fu";
SOLDER AREA: PLATED OVER TIN;
 - SHELL: NI PLATED OVER ALL ;
- RECINNEBDED PCB THICKNESS: 1.60mm;
- ELECTRICAL:
 - VOLTAGE RATING: 30 VAC RMS;
 - CURRENT RATING: 1.5 AMP;
 - CONTACT RESISTANCE: 30MILLIOHMS MAX.;
 - WITHSTAND VOLTAGE: 500 VAC RMS
50(60)Hz,1MIN.;
 - INSULATION RESISTANCE: 100MEGOHMS MIN
@500V DC;
- MECHANICAL:
 - MATING FORCE: 35N MAX.;
 - UNMATING FORCE: 5~35N;
 - OPERATING LIFE: 1500 CYCLES MIN.;
- ENVIRONMENTAL:
 - STORAGE TEMPERATURE RANGE: -40°C~+85°C;
 - OPERATION TEMPERATURE RANGE: -25°C~+70°C;
- SALT SPRAY TEST:24H(EXCLUDING RIVETED BENDS)
- SOLDERABILITY: 245±5°C,5±0.5S

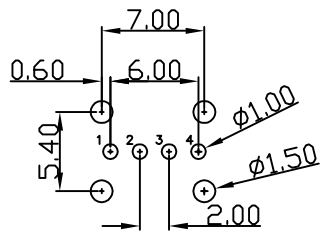
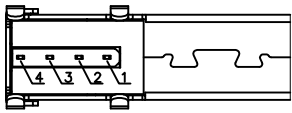
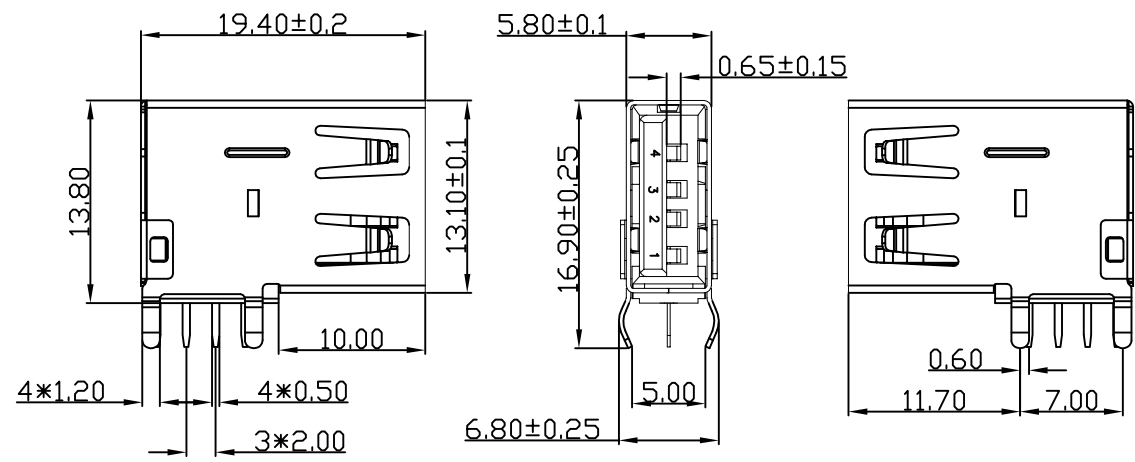
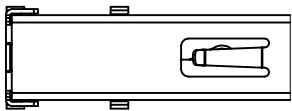

RECOMMEND PCB LAYOUT(±0.05)

C	外壳	SPCC	镀镍	
B	端子	黄铜-165	焊料区镀锡 接触区镀金	
A	底座	PBT	白色	
序号	品名	材质	电镀/颜色	备注

深圳市虹成电子有限公司

UNLESS GENERAL TOLERANCE: X.xxx ±0.10 X.xx ±0.20 X.x ±0.30	OTHERWISE: X.xx' ±1' X.x' ±3' X.' ±5'	NAME:	A母侧插长体平口 (K脚1.2*6.8) 白胶		P/N:	HC-USB2.0-L195-P	
		DRAW NO.:					
THIRD ANGLE PROJECTION		UNIT:	SCALE:	SIZE:	SHEET:	REV.:	
DRAWN:		mm	1:1	A4	1/1	A1	
CHECKED:		APPROVED					