

## SOT-89 Encapsulate Adjustable Reference Source

Adjustable Accurate Reference Source

### DEVICE DESCRIPTION

The TL432A is a three-terminal Shunt Voltage Reference providing a highly accurate 1.24V. The TL432A thermal stability and wide operating current, makes it suitable for all variety of applications that are looking for a low cost solution with high performance.

### FEATURES

- Low dynamic output impedance
- The effective temperature compensation in the working range of full temperature
- Low output noise voltage
- Fast on-state response
- Sink current capability of 0.1mA to 100mA

### APPLICATION

- Shunt Regulator
- High-Current Shunt Regulator
- Precision Current Limiter

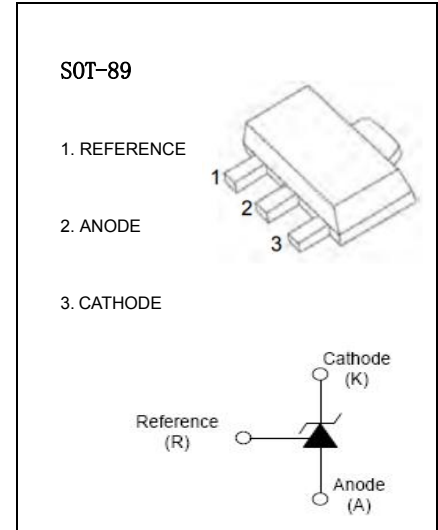

### ABSOLUTE MAXIMUM RATINGS (Operating temperature range applies unless otherwise specified)

Parameter	Symbol	Value	Units
Cathode Voltage	$V_{KA}$	18	V
Cathode Current Range (continuous)	$I_{KA}$	100	mA
Reference Input Current Range	$I_{ref}$	6	$\mu A$
Power Dissipation	$P_D$	350	mW
Thermal Resistance from Junction to Ambient	$R_{\theta JA}$	357	$^{\circ}C/W$
Operating Temperature	$T_{opr}$	$\sim +70$	$^{\circ}C$
Junction Temperature	$T_J$	150	$^{\circ}C$
Storage Temperature	$T_{stg}$	-65~+150	$^{\circ}C$

## ELECTRICAL CHARACTERISTICS ( $T_a=25^\circ\text{C}$ unless otherwise specified)

Parameter	Symbol	Test conditions	Min	Typ	Max	Unit
Reference input voltage (Fig 1)	$V_{\text{ref}}$	$V_{\text{KA}}=V_{\text{REF}}, I_{\text{KA}}=10\text{mA}$	1.2214		1.2586	V
Deviation of reference voltage over full temperature range (Fig 1)	$\Delta V_{\text{ref(DEV)}}$	$V_{\text{KA}}=V_{\text{REF}}, I_{\text{KA}}=10\text{mA}$ $0^\circ\text{C}\leq T_a\leq 70^\circ\text{C}$			16	mV
Ratio of change in reference input voltage to the change in cathode voltage (Fig 2)	$\Delta V_{\text{ref}}/\Delta V_{\text{KA}}$	$I_{\text{KA}}=10\text{mA}$ , $\Delta V_{\text{KA}}=1.25\text{V}\sim 15\text{V}$			2.4	mV/V
Deviation of reference input current over full temperature range (Fig 2)	$\Delta I_{\text{ref}}/\Delta T$	$I_{\text{KA}}=10\text{mA}$ , $R_1=10\text{k}\Omega$ , $R_2=\infty$ , $0^\circ\text{C}\leq T_a\leq 70^\circ\text{C}$			0.6	$\mu\text{A}$
Minimum cathode current for regulation (Fig 1)	$I_{\text{KA(min)}}$	$V_{\text{KA}}=V_{\text{REF}}$			0.1	mA
Off-state cathode current(Fig 3)	$I_{\text{off}}$	$V_{\text{KA}}=15\text{V}, V_{\text{REF}}=0$			0.5	$\mu\text{A}$
Dynamic impedance	$Z_{\text{KA}}$	$V_{\text{KA}}=V_{\text{REF}}, I_{\text{KA}}=0.1\sim 20\text{mA}$ , $f\leq 1.0\text{kHz}$			0.5	$\Omega$

## CLASSIFICATION OF $V_{\text{ref}}$

Rank	1%	1.5%
Range	1.2276~1.2524	1.2214~1.2586

## Typical Characteristics

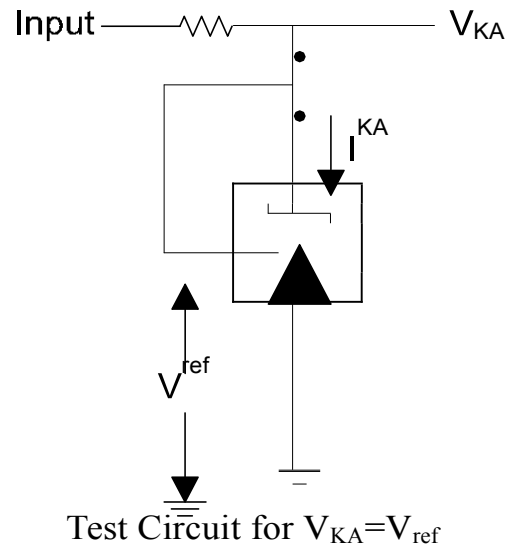
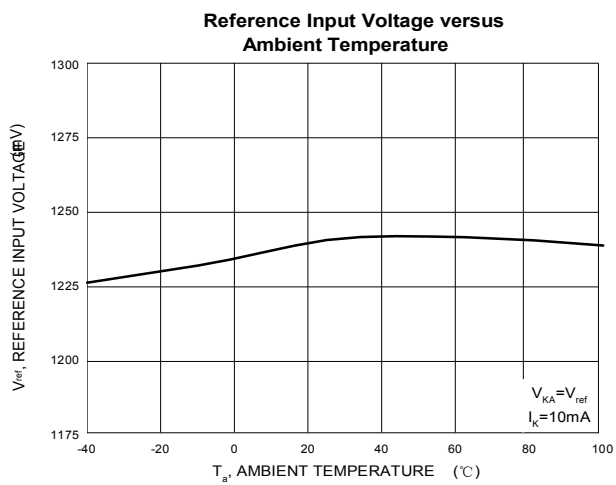
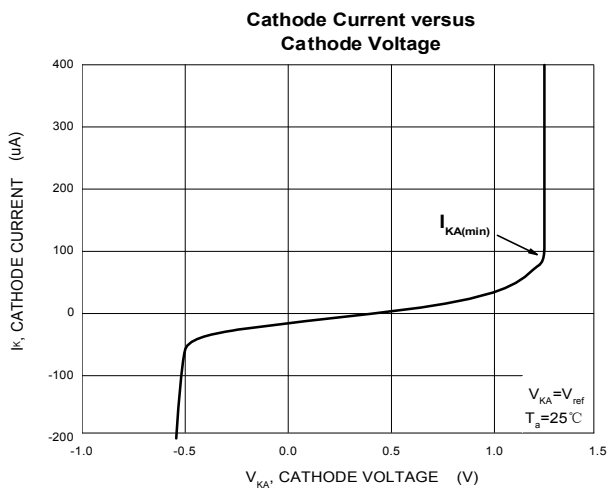
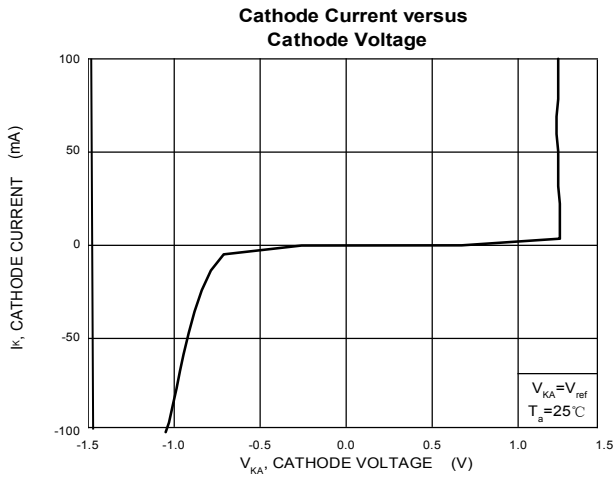

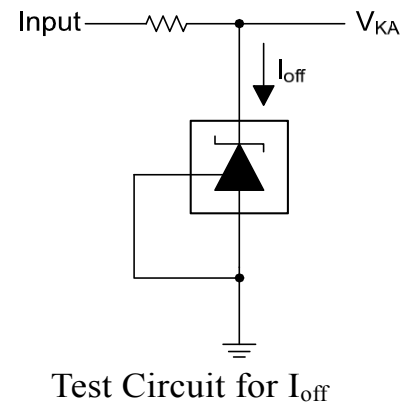
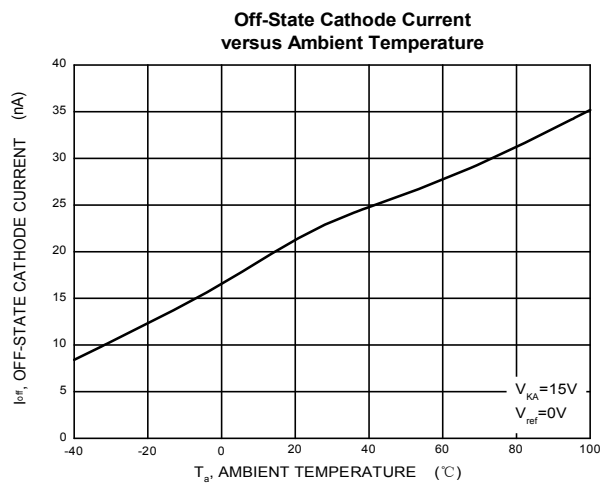
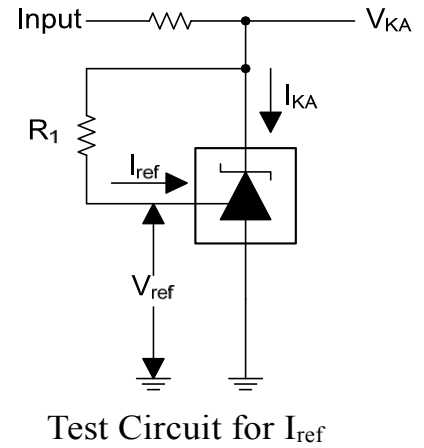
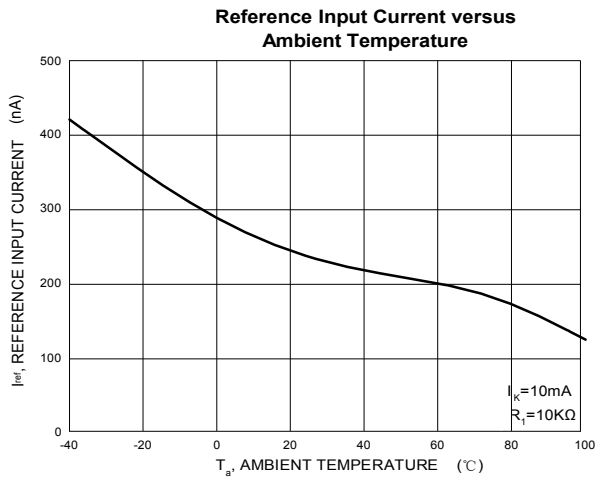
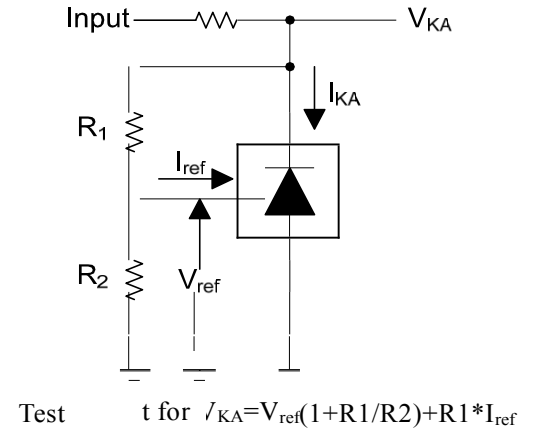
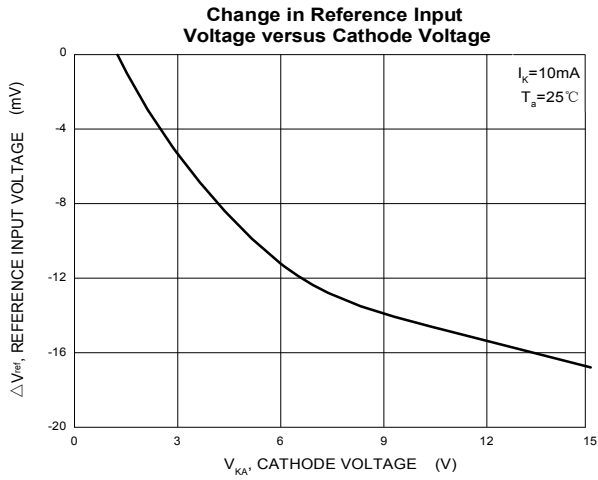

SOT-89 Package Outline Dimensions

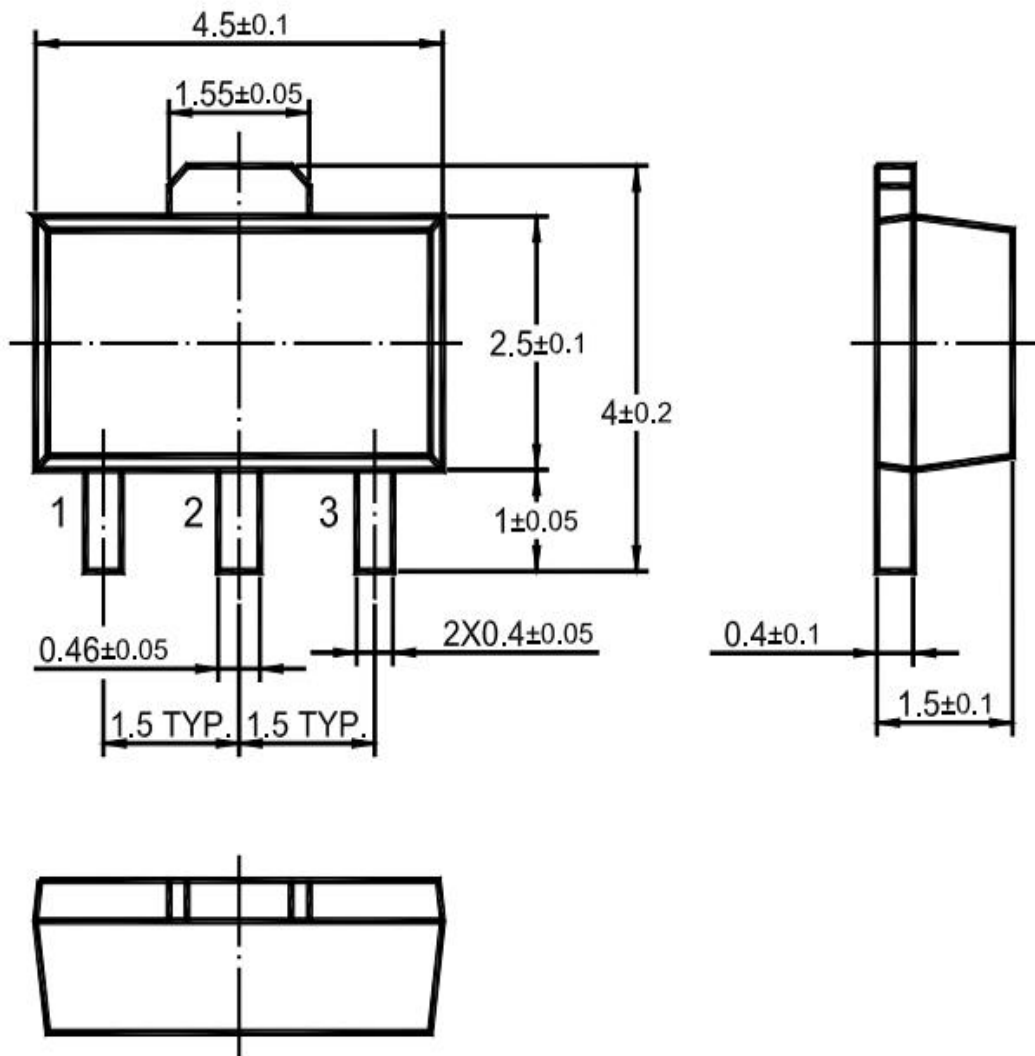

Dimensions in mm