

ohne Ansaughaube - without hood

Verpackt im Gurt in Anlehnung an DIN IEC 60286-3
 tape on reel packaging according to DIN IEC 60286-3
 Verpackungseinheit: 280 Stück
 packaging unit: 280 pcs

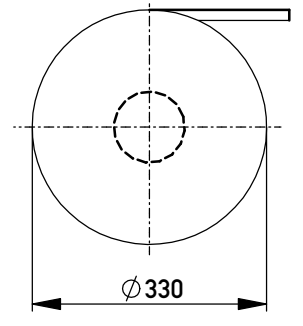

Abspulrichtung - Reel off Direction

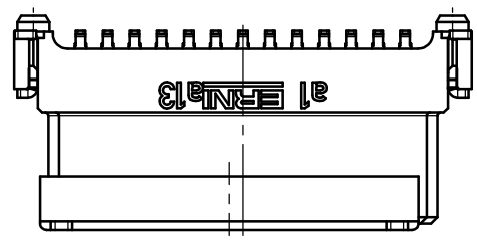
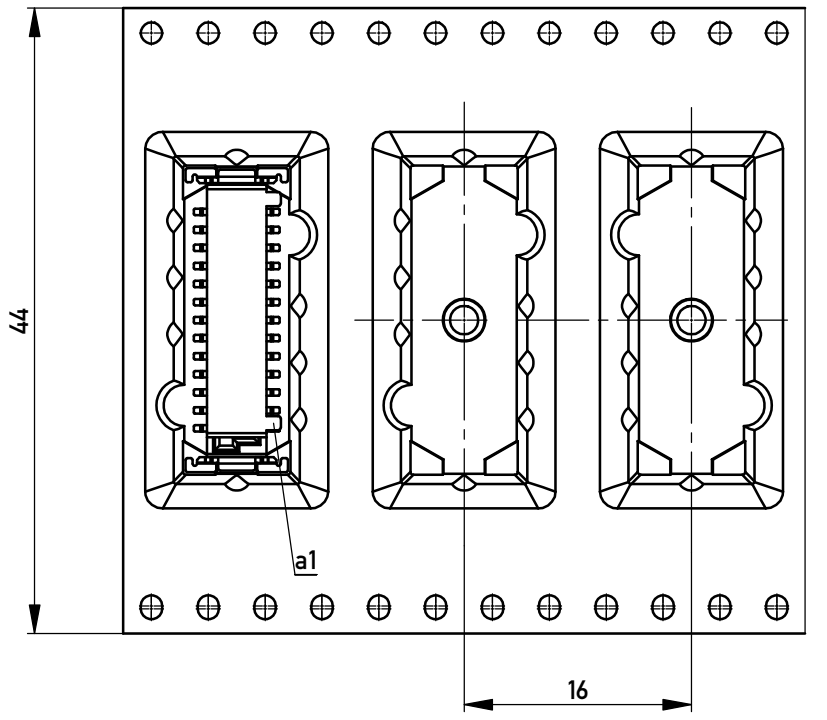
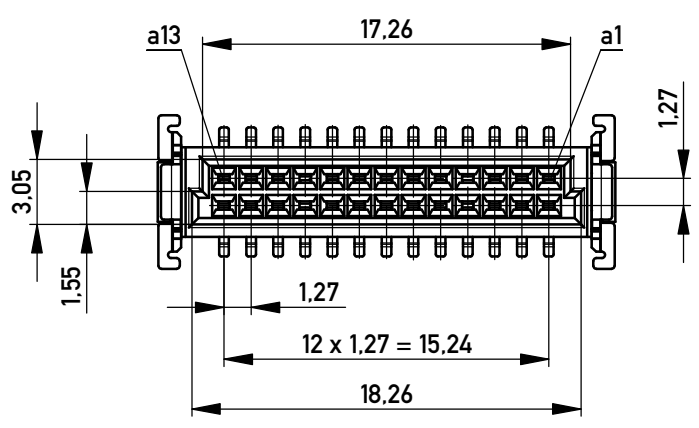
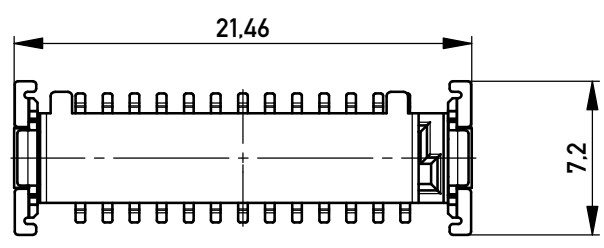

Anforderungsstufe 1
 performance level 1
 Kontaktbereich vergoldet
 mating area gold plating
 Anschlussbereich verzinkt 4-6 µm
 terminal area 4-6 µm tin plating
 Koplanarität der Anschlüsse ≤ 0,1 mm
 coplanarity area of termination ≤ 0,1 mm

Leiterplatten-Layout Vorschlag für SMT
 PCB-Layout Proposal for SMT

BA 6-03 - Standard Bauhöhe
 type 6-03 - standard assembly height

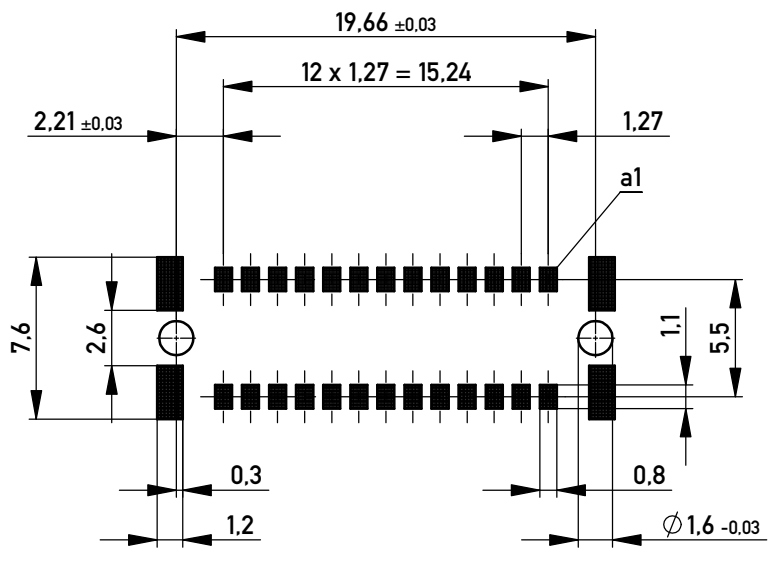

Information: All rights reserved. Only for Information. To ensure that this is the latest version of this drawing, please contact one of the ERNI companies before using.	Tolerances All Dimensions in mm	Scale 3:1
		Designation Federl. SMC-B-26-SMD-BA6-03 Female SMC-B-26-SMT-type6-03
www.ERNI.com		124044
c Index	07.09.2018 Date	Class SMCB

Copyright by ERNI Production GmbH & Co. KG
 Proprietary notice pursuant to ISO 16016 to be observed.