



ZHEJIANG UNIÜ-NE Technology CO., LTD

浙江宇力微新能源科技有限公司



U3503E Data Sheet

V 3.2

版权归浙江宇力微新能源科技有限公司

120V Input, 1.5A, Switching Current Limit Step-Down Converter

General Description

The U3503E is a high-voltage, step-down, switching regulator that delivers up to 2A of max current to the load. It integrates a high-side, high-voltage, power MOSFET with a current limit of 5A, typically. The wide 10V to 120V input range accommodates a variety of step-down applications, making it ideal for automotive, industry, and lighting applications. Hysteretic voltage-mode control is employed for very fast response. UNI's proprietary feedback control scheme minimizes the number of required external components.

The switching frequency is 120KHz, allowing for small component size. Thermal shutdown and short-circuit protection (SCP) provide reliable and fault-tolerant operations. Low quiescent current allows the U3503E to be used in battery-powered applications.

The U3503E is available in a ESOP-8 package with an exposed pad.

The U3503E can cooperate with MCU to test VIN voltage(TE PIN), control internal logic shutdown and realize zero power consumption.

Key Features

- Wide 10V to 120V Input Range
- Built-In 120V/96mΩ MOSFET
- Built-in Bootstrap Diode
- Hysteretic Control: No Compensation
- 120KHz Switching Frequency
- PWM Dimming Control Input for step-down Application
- Short-Circuit Protection (SCP) with Integrated High-Side MOSFET
- Low Quiescent Current
- Thermal Shutdown
- Available in a ESOP-8 Package with an Exposed Pad

Applications

- Scooters, E-Bike Control Power Supplies
- Solar Energy Systems
- Automotive System Power
- Industrial Power Supplies
- High-Power LED Drivers
- USB

Typical Application

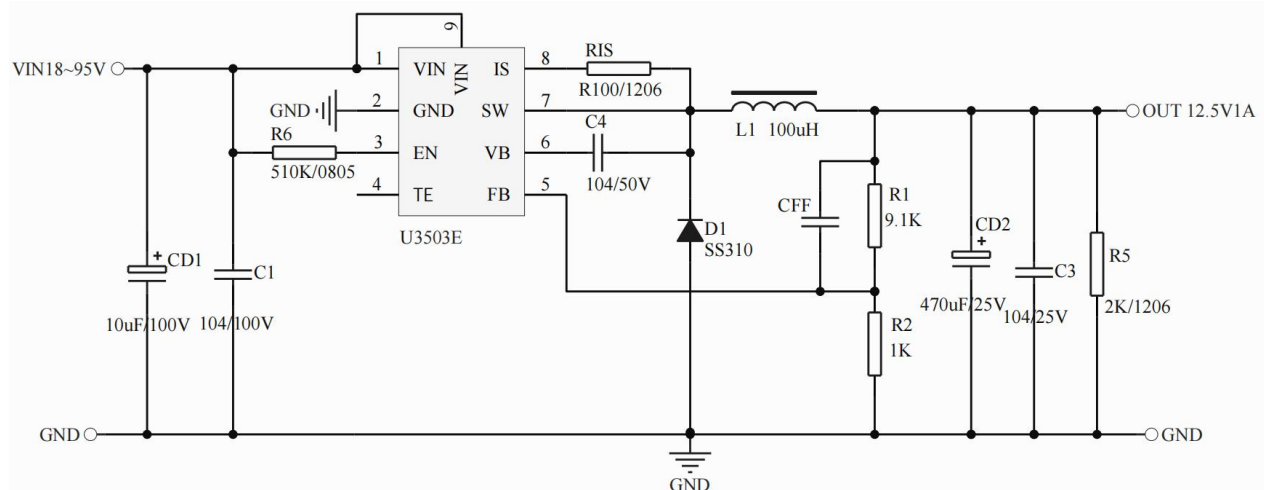

Ordering Information

Part Number	Package	Rdson	Vo	VINMAX	Load Current	Description
U3503E	ESOP-8	96mΩ	>2V	120V	Io<=1500mA	4000Pcs/Reel

Pin Description

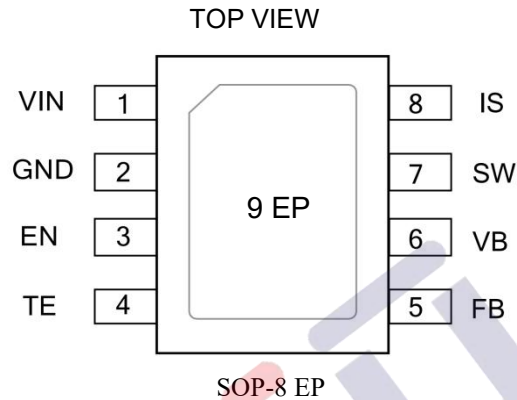

Pin Functions

SOP-8 EP Pin #	Name	Description
1	VIN	Input supply. VIN supplies power to all of the internal control circuitries, both BST regulators, and the high-side switch. A decoupling capacitor to ground must be placed close to VIN to minimize switching spikes.
2	GND	Ground. GND should be placed as close to the output capacitor as possible to avoid the high-current switch paths. Connect the exposed pad to GND plane for optimal thermal performance.
3	EN	Enable input. Pull EN below the specified threshold to shut down the U3503E. Pull EN above the specified threshold or leave EN floating to enable the U3503E.
4	TE	Test VIN voltage (TE PIN). control internal logic shutdown and realize zero power consumption. The ratio of pull-up resistance to pull-down resistance is about 30/1.
5	FB	Feedback. FB is the input to the voltage hysteretic comparators. The average FB voltage is maintained at 200mV by loop regulation.
6	VB	Boot. BST is the positive power supply for the internal, floating, high-side MOSFET driver. Connect a bypass capacitor between BST and SW.
7	SW	Switch node. SW is the output from the high-side switch. A low forward voltage Schottky rectifier to ground is required. The rectifier must be placed close to SW to reduce switching spikes.
8	IS	Current detection. Current Sensing Input.
9	EP	Input supply. VIN supplies power to all of the internal control circuitries, both BST regulators, and the high-side switch. A decoupling capacitor to ground must be placed close to VIN to minimize switching spikes.

Block Diagram

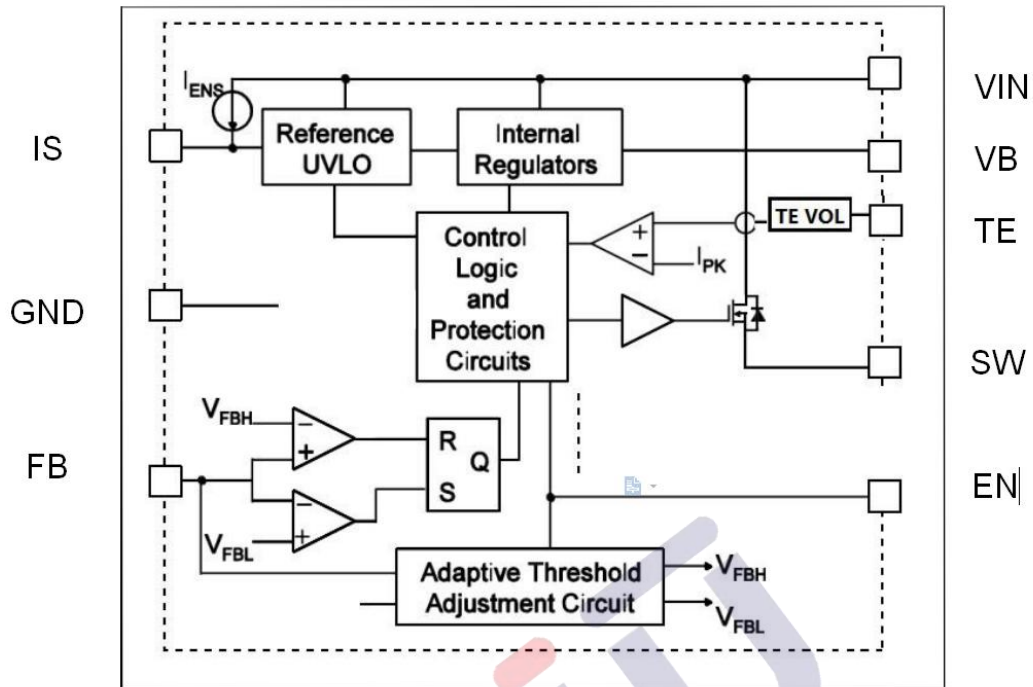

Figure 1:Function Block Diagram

Absolute Maximum Ratings (Note 1)

Parameter	Value	Unit
VIN,SW Pin Voltage Range	-0.3 to 120	V
VB Supply Voltage	120+7	V
VB Clamp Current	1	mA
FB, IS, EN Voltage Range	-0.3 to 7	V
Package Thermal Resistance ---Junction to Ambient (ESOP-8)	165	°C/W
Maximum Junction Temperature	160	°C
Storage Temperature Range	-65 to 150	°C
Lead Temperature (Soldering, 10sec.)	260	°C
ESD Capability, HBM (Human Body Model)	3	kV
ESD Capability, MM (Machine Model)	250	V

Electrical Characteristics

$V_{IN} = 60V$, $T_A = +25^{\circ}C$, unless otherwise noted. Specifications over temperature are guaranteed by design and characterization.

Parameter	Symbol	Condition	Min	Typ	Max	Units
VIN UVLO threshold			—	10.0	—	V
VIN UVLO hysteresis			—	0.4	—	V
Shutdown supply current		$V_{EN} = 0V$	—	1.8	—	μA
Quiescent supply current		No load, DIM = low, $V_{FB} = 1.25V$	—	300	—	μA
Upper switch on resistance	$R_{DS(ON)}$	$V_{BST} - V_{SW} = 5V$	—	150	—	m Ω
Upper switch leakage current	I_{SWLK}	$V_{EN} = 0V$, $V_{SW} = 0V$	—	0.02	1.5	μA
Current limit	I_{PK}	$V_{FB} = 1.25V$	—	3	—	A
Working frequency	F_{SW}		—	120	—	KHz
EN -on	V_{ENH}		—	2.8	7	V
EN -off	V_{ENL}		—	—	1	V
EN threshold hysteresis	V_{ENHY}		—	500	—	mV
EN input current	I_{ENI}	$V_{EN} = 5V$	—	0.01	1.5	μA
EN pull-up current	I_{ENS}	$V_{EN} = 2V$	—	2	3	μA
Feedback voltage threshold	V_{FBH}		1.23	1.25	1.30	V
FB input current	I_{FB}	$V_{FB} = 5V$ or $0V$	-800	—	800	nA
FB propagation delay to output high	T_{FBDH}	Falling edge of V_{FB} from 1.25V to 0V to V_{SW} rising edge	—	100	—	ns
FB propagation delay to output high	T_{FBDL}	Rising edge of V_{FB} from 0V to 1.25V to V_{SW} falling edge	—	100	—	ns
Thermal shutdown		Trigger thermal shutdown	—	150	—	C
		Hysteresis	—	20	—	

NOTES:

Note1. Stresses listed as the above “Maximum Ratings” may cause permanent damage to the device. These are for stress ratings. Functional operation of the device at these or any other conditions beyond those indicated in the operational sections of the specifications is not implied. Exposure to maximum rating conditions for extended periods may remain possibility to affect device reliability.

Note2. The device is not guaranteed to function outside its operating conditions.

Note3. Guaranteed by design.

Typical Characteristics

$V_{IN} = 60V$, $T_A = +25^{\circ}C$, unless otherwise noted.

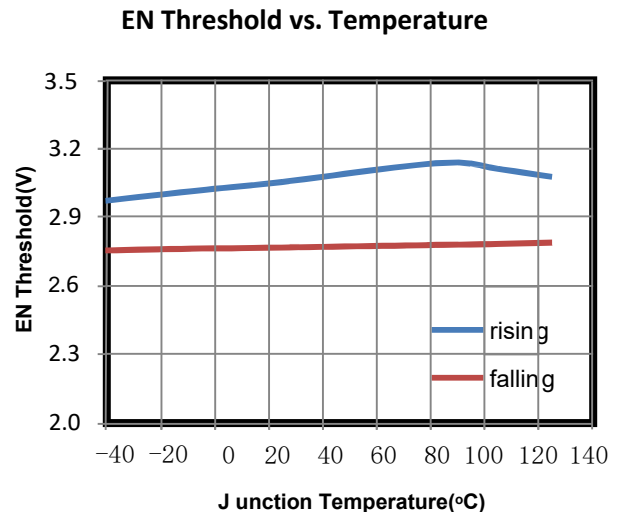
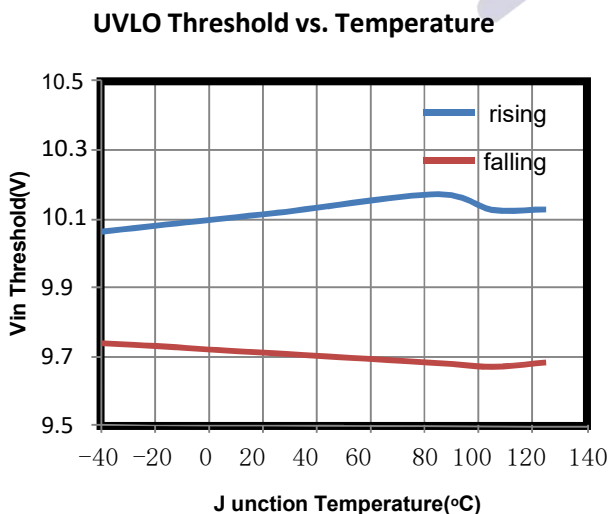
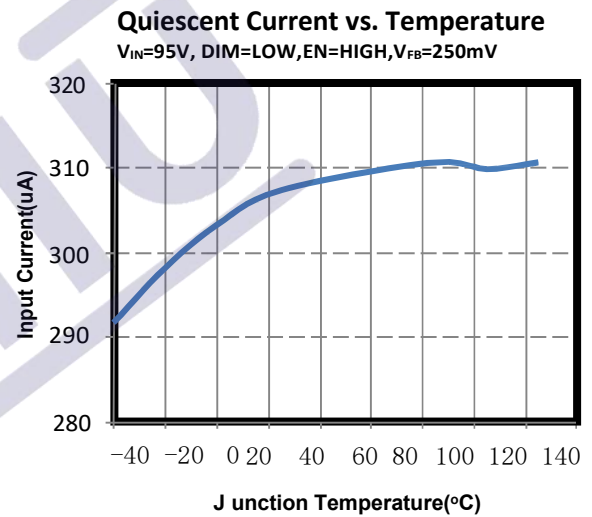
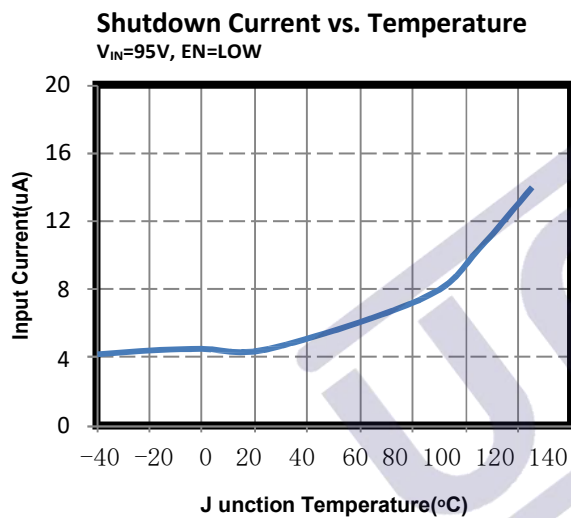
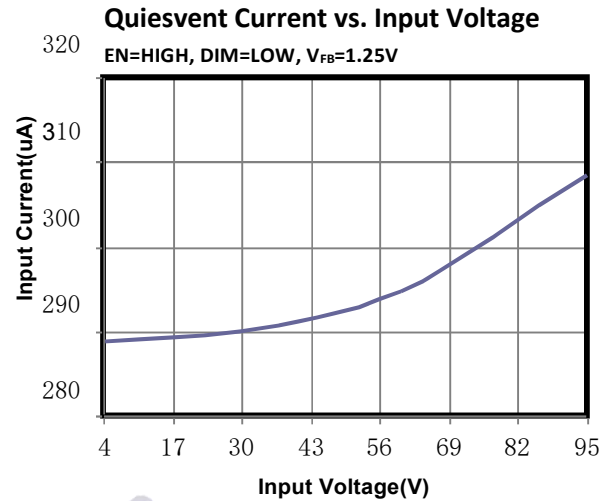
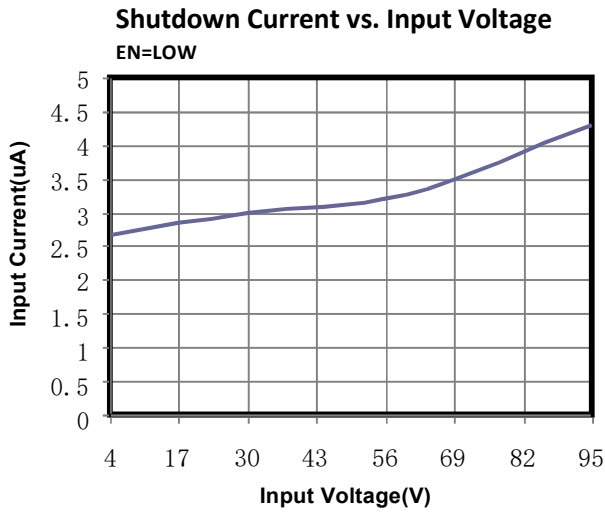

Typical Performance Characteristics

$V_{IN} = 60V, V_{OUT} = 12V, I_{OUT} = 1A, L = 47\mu H, C_{OUT} = 100\mu F, T_A = +25^\circ C$, unless otherwise noted.

Efficiency vs. Output Current

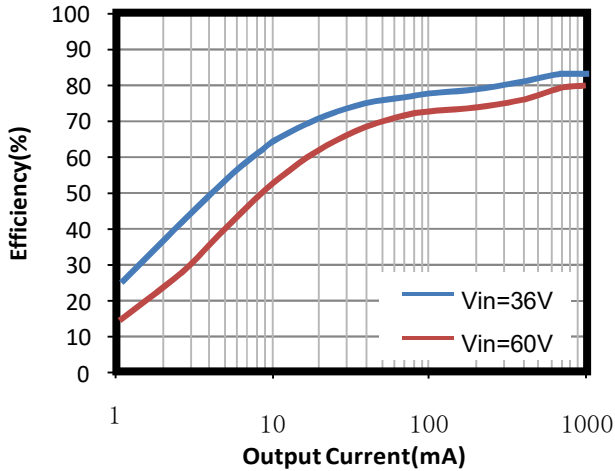

Load Regulation

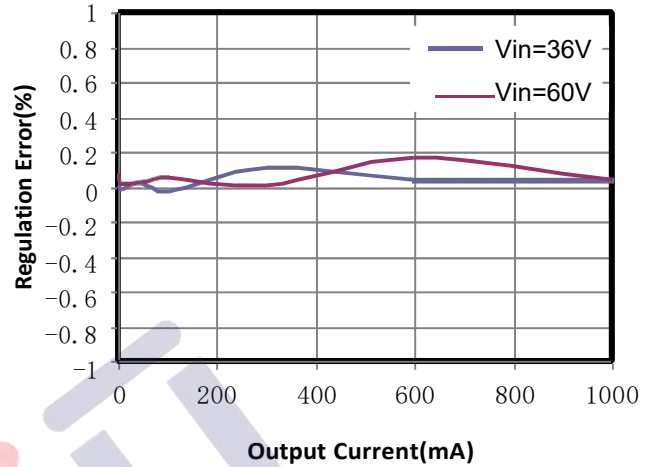

Line Regulation

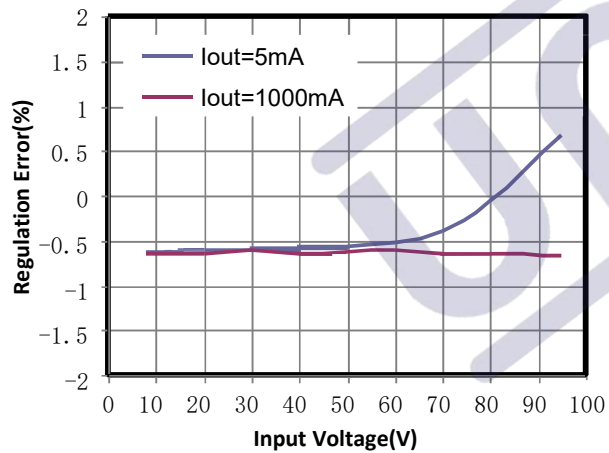

Operation

Hysteresis Current Control with Adaptive Threshold Adjustment

The U3503E operates in a hysteretic voltage-control mode to regulate the output voltage. FB is connected to the tap of a resistor divider, which determines the output voltage. The power MOSFET is turned on when the FB voltage (V_{FB}) rises to F_{Bon} and remains on until V_{FB} rises to F_{Boff} . The power MOSFET is turned off when V_{FB} drops to F_{Boff} and remains off until V_{FB} falls to F_{Bon} . The two thresholds of F_{Bon} and F_{Boff} are adjusted adaptively to compensate for all the circuit delays, so the output voltage is regulated with an average 1.25V value at FB.

Enable (EN) Control

The U3503E has a dedicated enable control pin (EN) with positive logic. Its falling threshold is 2.5V, and its rising threshold is 2.8V.

When EN is pulled up to about 3V by an internal current source, so it is enabled.

Floating Driver and Bootstrap Charging

The floating power MOSFET driver is powered by an external bootstrap capacitor. This floating driver has its own under-voltage lockout (UVLO) protection. The UVLO rising threshold is 10V with a threshold error of 0.2V.

The bootstrap capacitor is charged and regulated to about 5V by the dedicated internal bootstrap regulator.

If the internal circuit does not have sufficient voltage, and the bootstrap capacitor is not sufficiently charged, extra external circuitry can be used to ensure that the bootstrap voltage is in the normal operating region. Refer to the External Bootstrap Diode section for more details.

Under-Voltage Lockout (UVLO)

Under-voltage lockout (UVLO) is implemented to protect the chip from operating at an insufficient supply voltage. The UVLO rising threshold is about 10V, while its falling threshold is a consistent 9.5V.

Fast charging Function for USB Applications

Because the FB reference of the U3503E is very flexible, it is recommended to use the U3503E for USB Fast charging Applications by connecting the current sense resistor between FB and GND.

Thermal Shutdown

Thermal shutdown is implemented to prevent the chip from operating at exceedingly high temperatures. When the silicon die temperature is higher than its upper threshold, the entire chip shuts down. When the temperature is lower than its lower threshold, the chip is enabled again.

Output Short Protection

The output voltage is well-regulated when V_{FB} is around 1.25V. If the output is pulled low in over-current protection (OCP) or is shorted to GND directly, V_{FB} is low, even though the power MOSFET is turned on. The U3503E regards the low V_{FB} as a failure. The power MOSFET shuts off if the failure time is longer than 10 μ s. The U3503E attempts operation again after a delay of about 300 μ s.

The power MOSFET current is also accurately sensed via a current sense MOSFET. If the current is over the current limit, the IC is shut down. This offers extra protection under output-short conditions.

Application Information

Setting the Output Voltage

The output voltage (V_{OUT}) is set by a resistor divider ($R1$ and $R2$) (see the Typical Application on page 1). To achieve good noise immunity and low power loss, $R2$ is recommended to be in the range of $1k\Omega$ to $50k\Omega$. $R1$ can then be determined with Equation (1):

$$R1 = \frac{V_{OUT} - V_{FB}}{V_{FB}} \times R2 \quad (1)$$

Where V_{FB} is 1.25V, typically.

Setting the Output current

The output current (I_{OUT}) is set by a resistor divider (R_{IS}) (see the Typical Application on page 1). I_{OUT} can then be determined with Equation (2):

$$I_{OUT} = \frac{V_{LIMIT}}{R_{IS}} \times \eta \quad (2)$$

Where $V_{LIMIT}=0.18V$, typically.

Output Capacitor and Frequency Setting

The output capacitor (C_{OUT}) is necessary for achieving a smooth output voltage. The ESR of the capacitor should be sufficiently large compared to the capacitance; otherwise, the system may behave in an unexpected way, and the current ripple may be very high. V_{FB} changes from 1.22V to 1.28V when the power MOSFET switches on. To charge the capacitor and generate 1.28V at FB, the system needs ESR and some inductor current. For example, for a 5V V_{OUT} , if the forward capacitor is $0.1\mu F$, the suggested ESR range of the output capacitor is $100m\Omega$ to $250m\Omega$. Tantalum or aluminum electrolytic capacitors with a small ceramic capacitor are recommended.

A forward capacitor across $R1$ is recommended when the output capacitor is tantalum or aluminum electrolytic, which can set the desired frequency if the output capacitor and ESR cannot be changed. The

forward capacitor can reduce the output voltage ripple. In some application, simply a forward capacitor may not get proper frequency, then we can add a forward resistor in series with the forward capacitor or even more add a ceramic on the output.

Selecting the Inductor

The inductor (L) is required to convert the switching voltage to a smooth current to the load. Although the output current is low, it is recommended that the inductor current be continuous in each switching period to prevent reaching the current limit. Calculate the inductor value with Equation (3):

$$L = \frac{(V_{IN} - V_{OUT}) \times V_{OUT}}{F_{SW} \times I_{OUT} \times V_{IN} \times K} \quad (3)$$

Where K is a coefficient of about 0.15 ~ 0.85

Output Rectifier Diode

The output rectifier diode supplies current to the inductor when the high-side switch is off. To reduce losses due to the diode forward voltage and recovery times, use a Schottky diode. The average current through the diode can be approximated with Equation (4):

$$I_D = I_{OUT} \times \left(1 - \frac{V_{OUT}}{V_{IN}}\right) \quad (4)$$

Choose a diode with a maximum reverse voltage rating greater than the maximum input voltage and a current rating is greater than the average diode current.

Input Capacitor (C_{IN})

The input current to the step-down converter is discontinuous and therefore requires a capacitor to supply AC current to the step-down converter while maintaining the DC input voltage. Use low ESR capacitors for the best performance, especially under high switching frequency applications.

The RMS current through the input capacitor can be calculated with Equation (5):

$$I_{IN_AC} = I_{OUT} \times \sqrt{\frac{V_{OUT}}{V_{IN}} \times \left(1 - \frac{V_{OUT}}{V_{IN}}\right)} \quad (5)$$

With low ESR capacitors, the input voltage ripple can be estimated with Equation (6):

$$\Delta V_{IN} = \frac{I_{OUT} \times V_{OUT}}{F_{SW} \times C_{IN} \times V_{IN}} \times \left(1 - \frac{V_{OUT}}{V_{IN}}\right) \quad (6)$$

Choose an input capacitor with enough RMS current rating and enough capacitance for small input voltage ripples.

When electrolytic or tantalum capacitors are applied, a small, high-quality ceramic capacitor (i.e.: 0.1 μ F) should be placed as close to the IC as possible.

External Bootstrap Diode

An external bootstrap diode may enhance the efficiency of the converter (see Figure 2).

The bootstrap diode can be a low-cost one. Optimize circuit structure, save cost, and reduce error rate for peripheral circuit configuration.

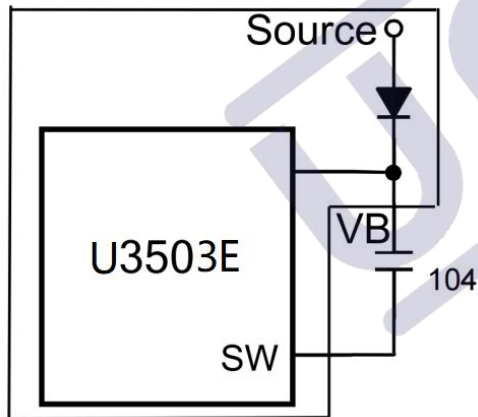

Figure 2: External Bootstrap Diode

PCB Layout Guidelines

Efficient PCB layout is critical for stable operation. For best results, refer to Figure 3 and follow the guidelines below.

1. Place the input decoupling capacitor, catch diode, and the U3503E (VIN, SW, and PGND) as close to each other as possible.
2. Keep the power traces very short and fairly wide, especially for the SW node. This can help greatly reduce voltage spikes on the SW node and lower the EMI noise level.
3. Run the feedback trace as far from the inductor and noisy power traces (like the SW node) as possible.
4. Place thermal vias with 15mil barrel diameter and 40mil pitch (distance between the centers) under the exposed pad to improve thermal conduction.

Typical Application Circuit

APP1: VIN = 18 ~ 95V, V_{OUT} = 12.5V, I_{OUT} = 1A

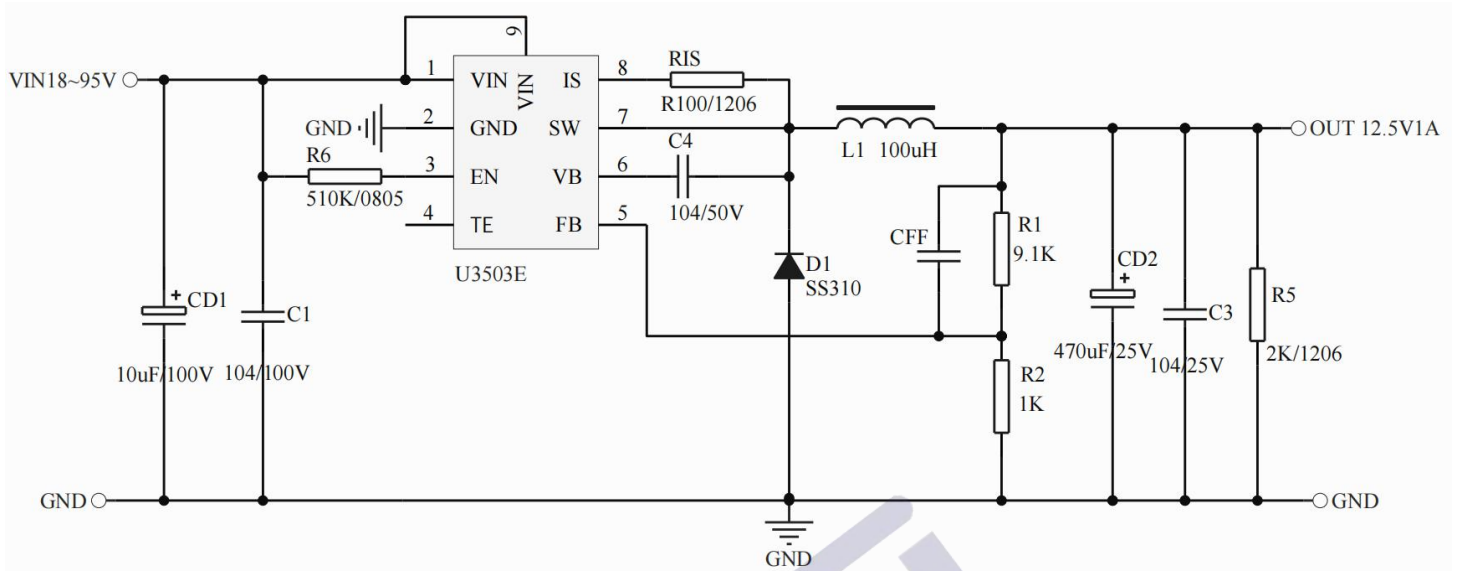

APP2: VIN = 18 ~ 95V, V_{OUT} = 5V, I_{OUT} = 1.5A

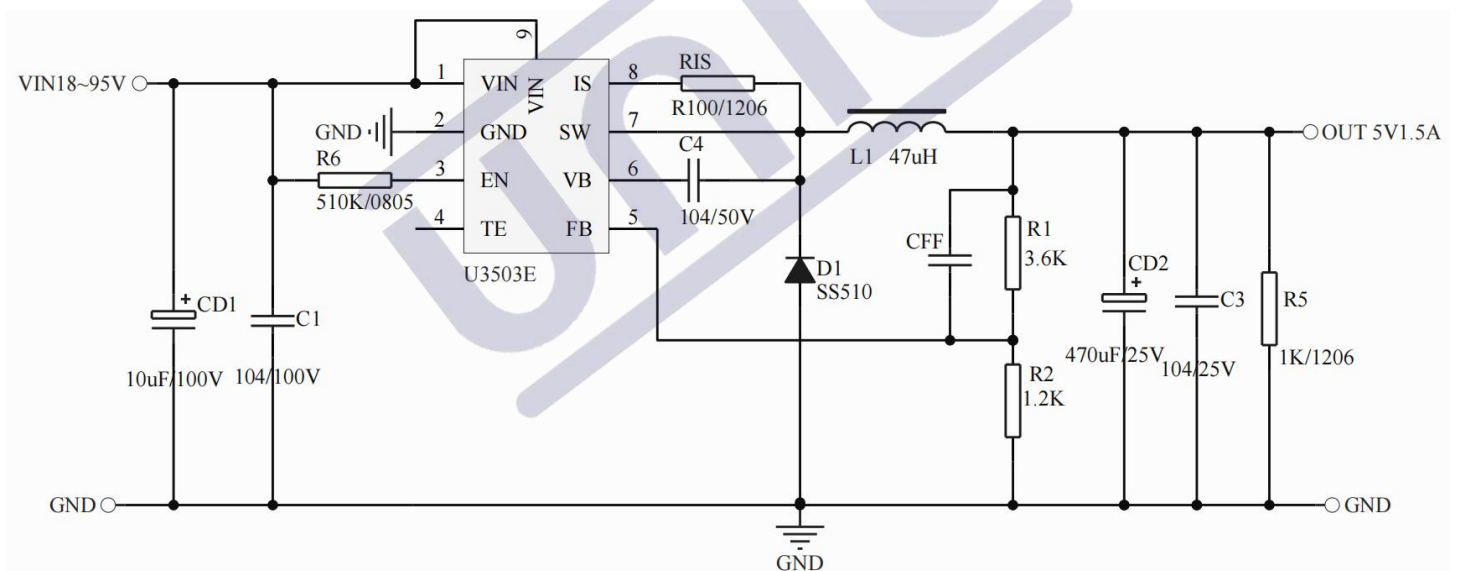

APP3: VIN = 18 ~ 95V, V_{OUT} = 12.5V, I_{OUT} = 1A(TE PIN zero power consumption)

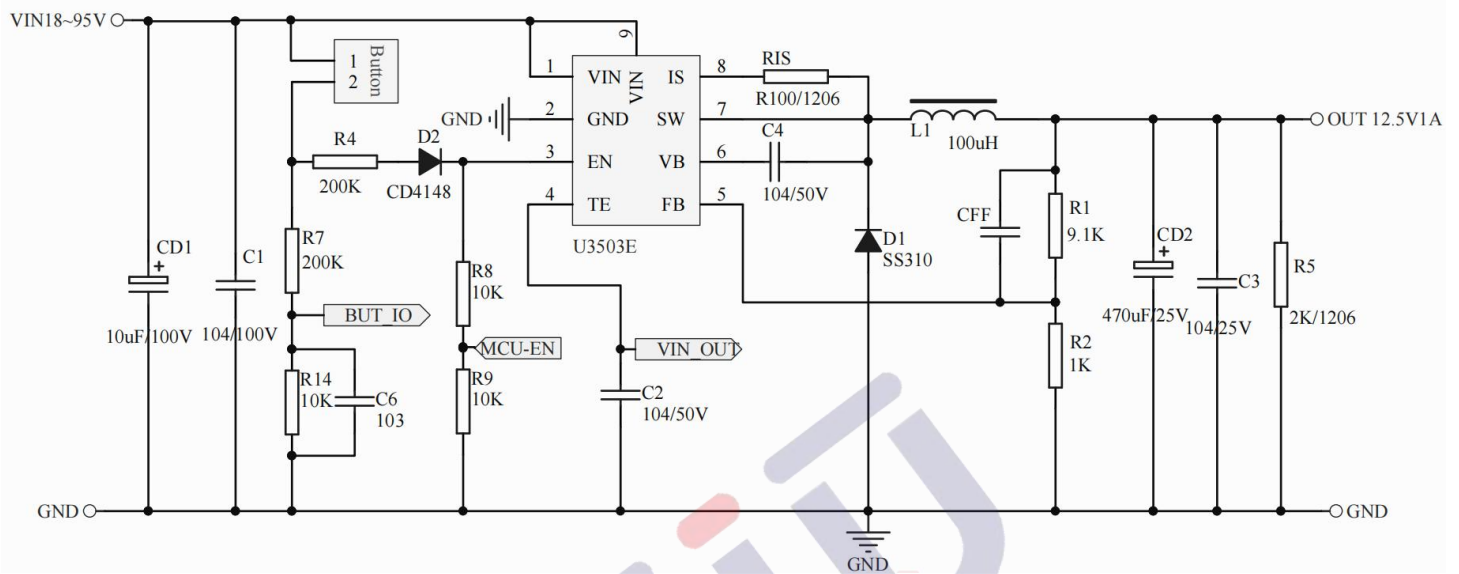

APP4: VIN = 18 ~ 95V, QC2.0/QC3.0

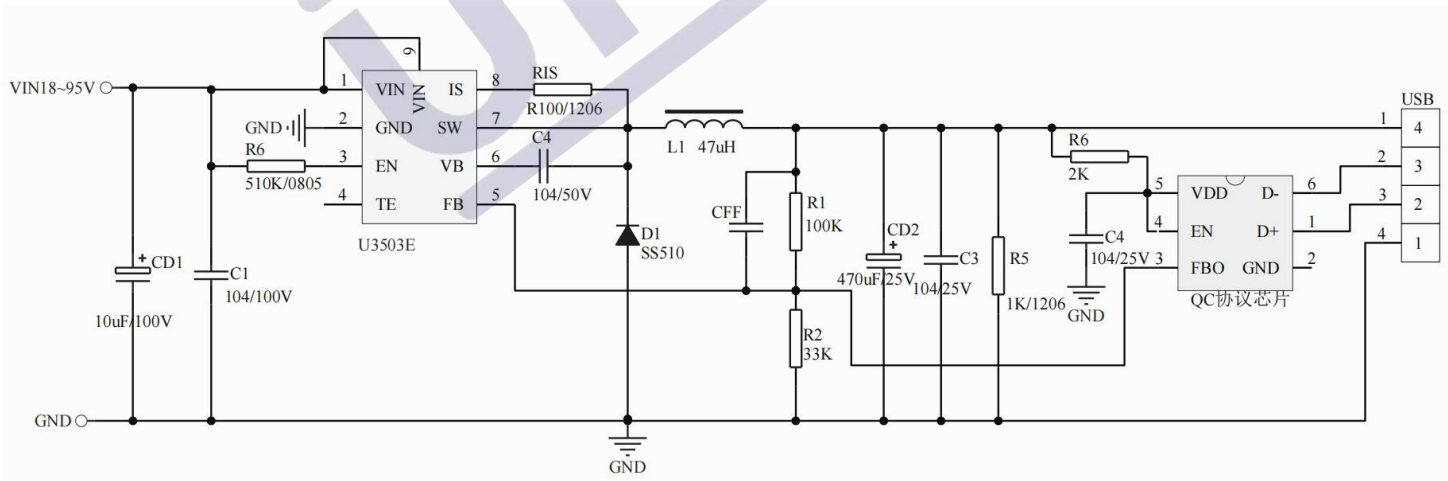

Package Information

SOP-8 EP

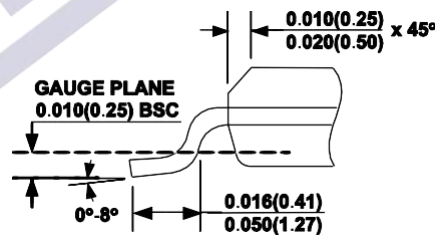
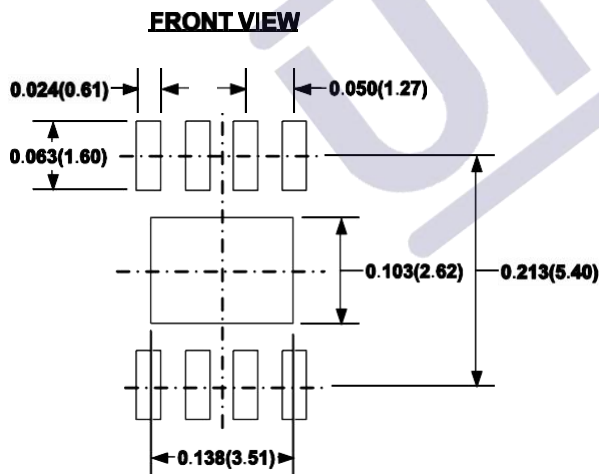
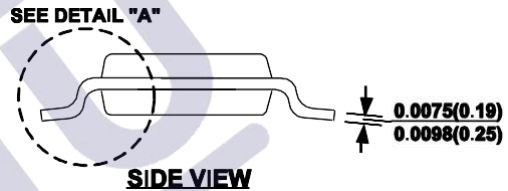
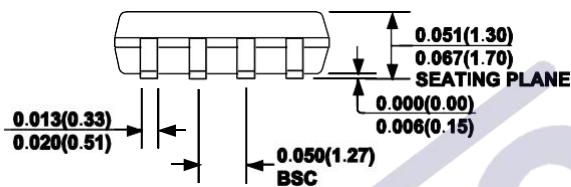
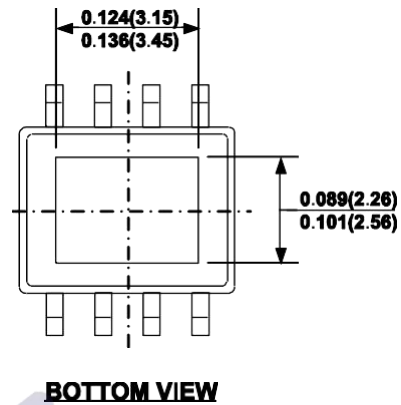
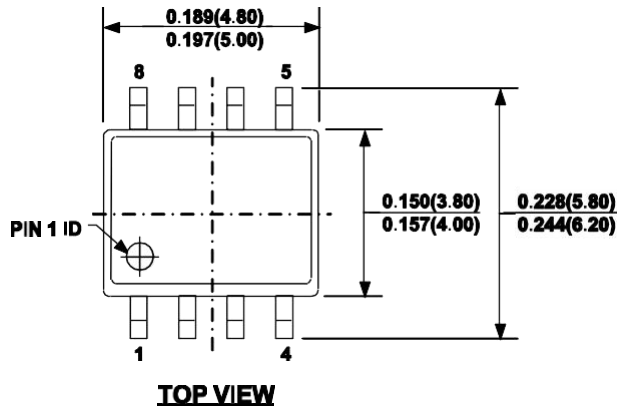

NOTE:

- 1) CONTROL DIMENSION IS IN INCHES. DIMENSION IN BRACKET IS IN MILLIMETERS.
- 2) PACKAGE LENGTH DOES NOT INCLUDE MOLD FLASH, PROTRUSIONS OR GATE BURRS.
- 3) PACKAGE WIDTH DOES NOT INCLUDE INTERLEAD FLASH OR PROTRUSIONS.
- 4) LEAD COPLANARITY (BOTTOM OF LEADS AFTER FORMING) SHALL BE 0.004" INCHES MAX.
- 5) DRAWING CONFORMS TO JEDEC MS-012, VARIATION BA.
- 6) DRAWING IS NOT TO SCALE.

NOTICE: The information in this document is subject to change without notice. Users should warrant and guarantee that third party Intellectual Property rights are not infringed upon when integrating UNI products into any application. UNI will not assume any legal responsibility for any said applications.

1.版本记录

DATE	REV.	DESCRIPTION
2018/02/16	1.0	First Release
2018/03/18	2.0	Package is changed to SOP-8
2019/05/20	3.0	Package is changed to ESOP-8
2020/10/15	3.1	Pin definition changed
2021/12/20	3.2	Rename CSM3502E to U3503E

2.免责声明

浙江宇力微新能源科技有限公司保留对本文档的更改和解释权力，不另行通知！产品不断提升，以追求高品质、稳定性强、可靠性高、环保、节能、高效为目标，我司将竭诚为客户提供性价比高的系统开发方案、技术支持等更优秀的服务。量产方案需使用方自行验证并自担所有批量风险责任。未经我司授权，该文件不得私自复制和修改。

版权所有 浙江宇力微新能源科技有限公司/绍兴宇力半导体有限公司

3.联系我们

浙江宇力微新能源科技有限公司

总部地址：绍兴市越城区斗门街道袍渚路25号中节能科创园45幢4/5楼

电话：0575-85087896（研发部）

传真：0575-88125157

E-mail: htw@uni-semic.com

无锡地址：无锡市新吴区纺城大道299号深港都会广场9-1401

电话：0510-85297939

E-mail: zh@uni-semic.com

深圳地址：深圳市宝安区航城街道三围社区南昌路上合工业园B2栋501

电话：0755-84510976

E-mail: htw@uni-semic.com