

SCALE 100:1

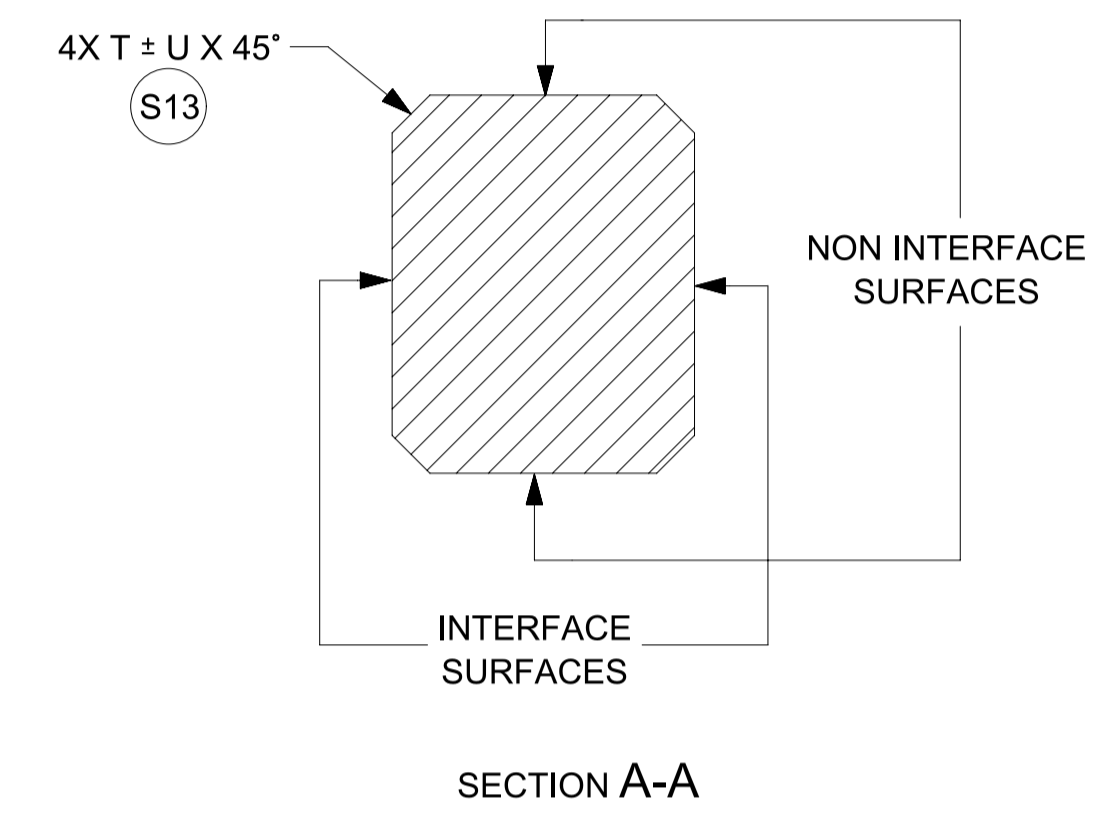
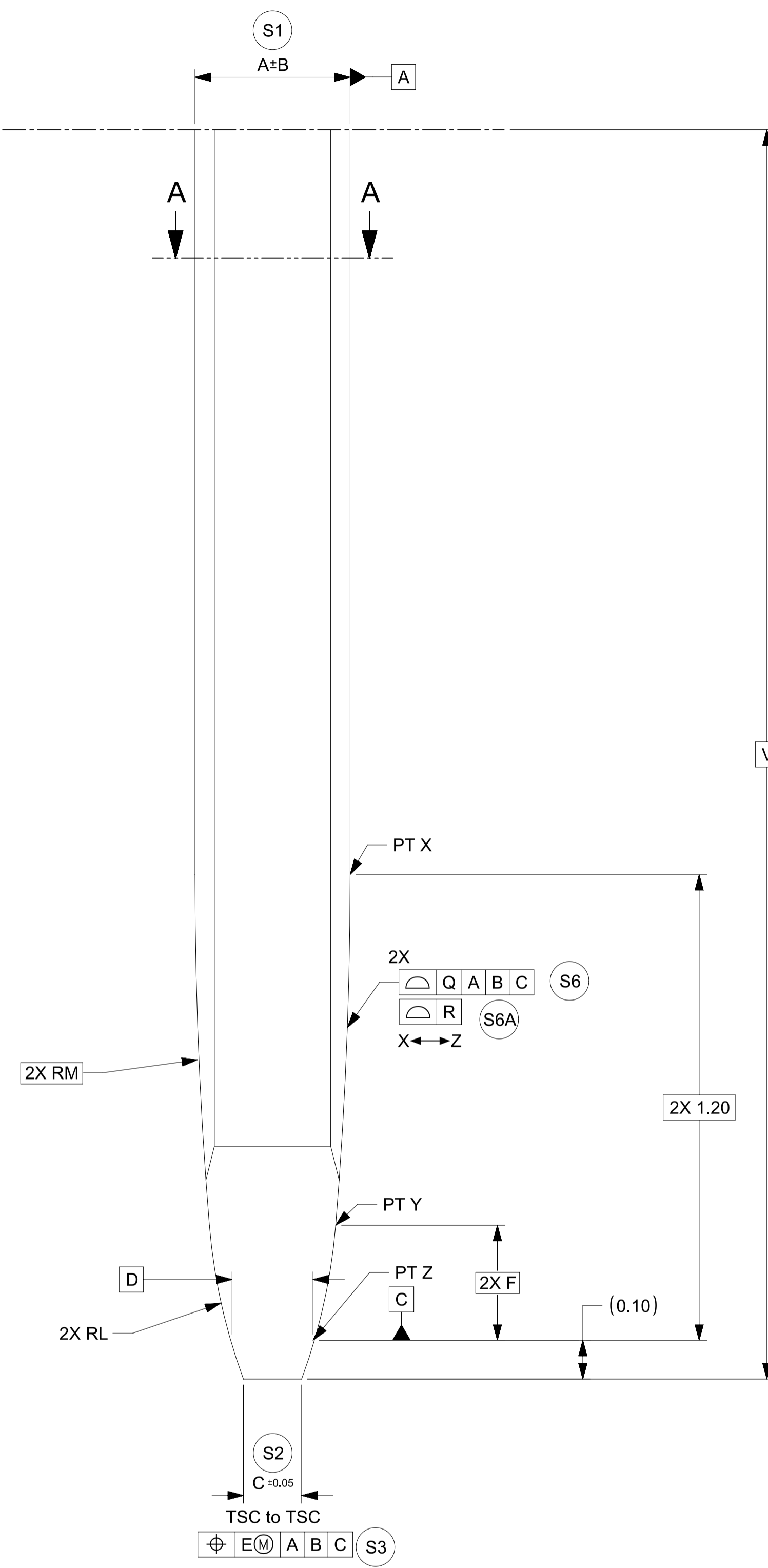

TABLE 1			DRAWING DIMENSIONS																		
Model NO.	Description	Application	A	B	C	D	E	F	G	H	J	L	M	N	P	Q	R	T	U	V	W
34735-0004_FM_000	0.50mm BLADE	HEADER	0.40	0.015	0.15	0.216	0.05	0.296	0.50	0.03	0.05	1.5	11	0.20	0.50	0.10	0.06	0.05	0.03	4.0 MIN	0.08
34735-0001_FM_000	0.64mm BLADE - NORMAL THICKNESS	HEADER	0.64	0.03	0.25	0.356	0.10	0.285	0.64	0.03	0.05	1	7	0.25	0.55	0.10	0.06	0.05	0.03	5.5 MIN	0.08
34735-0002_FM_000	0.64mm BLADE - REDUCED THICKNESS	HEADER	0.625	0.015	0.234	0.341	0.10	0.285	0.64	0.03	0.05	1	7	0.25	0.55	0.10	0.06	0.05	0.03	5.5 MIN	0.08
34735-0006_FM_000	1.20mm BLADE	HEADER	0.60	0.015	0.21	0.316	0.10	0.285	1.00	0.05	0.05	1	7	0.59	0.55	0.10	0.06	0.05	0.03	5.5 MIN	0.13
34735-0003_FM_000	1.50mm BLADE	HEADER	0.80	0.03	0.25	0.321	0.10	1.10	1.50	0.05	0.10	4.775	1.083	0.5	1.68	0.10	0.06	0.05	0.03	5.0 MIN	0.13
34735-0010_FM_000	2.8mm BLADE	HEADER	0.80	0.025	0.20	0.345	0.10	0.314	2.50	0.10	0.10	1	4	1.80	1.10	0.15	0.06	0.06	0.05	9.5 MIN	0.25
34735-0011_FM_000	6.3mm BLADE	HEADER	0.80	0.025	0.31	0.345	0.10	0.314	6.0	0.25	0.20	1	4	3.90	1.10	0.15	0.06	0.06	0.05	10.5 MIN	0.13
34735-0012_FM_000	1.20mm BLADE	INLINE	0.60	0.015	0.21	0.316	0.10	0.285	1.20	0.05	0.05	1	7	0.59	0.55	0.10	0.06	N/A	N/A	5.5 MIN	0.13

FUNCTIONAL SYMBOLS $\nabla_A = 0$ $\nabla_C = 0$ $\nabla_P = 0$ DIVISIONAL SYMBOLS	THIS DRAWING CONTAINS INFORMATION THAT IS PROPRIETARY TO MOLEX ELECTRONIC TECHNOLOGIES, LLC AND SHOULD NOT BE USED WITHOUT WRITTEN PERMISSION		CURRENT REV DESC:		 DESIGN STANDARD HEADER PIN & BLADE TIP GEOMETRY FOR MATING TO HARNESS TERMINALS PRODUCT SALES DRAWING
	DIMENSION UNITS	SCALE	PHASE: Design Production		
	mm	100:1	EC NO: CO-00000508		
	GENERAL TOLERANCES (UNLESS SPECIFIED)		DRWN: Raghavendra MV		
ANGULAR TOL ± 0.5°		APPR: Deepak Patil		2022-01-31	
4 PLACES ± 0.00000		CHKD: Nathan Song		2022-02-07	
3 PLACES ± 0.0150		APPR: Deepak Patil		2022-02-09	
2 PLACES ± 0.050		INITIAL REVISION:			
1 PLACE ± 0.10		DRWN: Raghavendra MV		2022-01-31	
0 PLACES ± 0.00		APPR: Deepak Patil		2022-02-09	
DRAFT WHERE APPLICABLE MUST REMAIN WITHIN DIMENSIONS		THIRD ANGLE PROJECTION	DRAWING	SERIES	DOCUMENT NUMBER
			A1-SIZE	34735	347350050
					CUSTOMER
					SHEET NUMBER
					2 OF 2

NOTES

1. GENERAL:

- 1.1. ALL PRODUCT SPECIFICATIONS AND THEIR RELATED DOCUMENTS USING THIS FEATURE MUST REFERENCE THIS DOCUMENT AS THE CONTROLLING SPECIFICATION AND USE THE SAME BALLOON NUMBERS.
- 1.2. COMPLIANCY TO THIS DOCUMENT:
 - a) COMPLIANCY MAY BE CLAIMED BY MEETING THE REQUIREMENTS IN THIS SPECIFICATION WITH THE DEVIATION IDENTIFIED AND MAY BE REFERENCED IN OTHER DOCUMENTS (DRAWINGS, DVP&R, ETC.) AS 'CONFORMS TO MOLEX 347350050 REV X.X'.
 - b) PRODUCTS DESIGNED AFTER THE DATE OF RELEASE OF THIS DOCUMENT SHALL BE COMPLIANT TO THE CURRENT REVISION OF THIS DOCUMENT.
 - c) PRODUCTS THAT HAVE MET PREVIOUS REVISION(S) OF THIS DOCUMENT SPECIFICATION SHALL STILL BE CONSIDERED 'MOLEX STANDARDS COMPLIANT' TO THOSE REVISIONS AND DO NOT NEED TO BE RE-VALIDATED.
- 1.3. DEVIATIONS TO THIS DOCUMENT ARE ALLOWABLE UNDER THE FOLLOWING CONDITIONS:
 - a) ALL DEVIATIONS SHALL SHOW EQUAL OR BETTER PERFORMANCE (ELECTRICAL/MECHANICAL) AS REQUIRED BY VALIDATION SPECIFICATION.
 - b) EXCEPTIONS ARE CLEARLY IDENTIFIED ON THE PRODUCT SPECIFICATION.
 - c) ALL DEVIATIONS ARE APPROVED BY THE FOLLOWING INDIVIDUALS:
 - PERSON WHO HAS INTERFACE RESPONSIBILITY
 - PERSON WITH DESIGN STANDARD APPROVER AUTHORITY
 - d) ALL RECORDS OF DEVIATION APPROVALS SHALL BE INCLUDED WITH CHANGE NOTICE DOCUMENTATION.

2. DESIGN - MATERIALS:

- 2.1. BASE MATERIAL TYPE : COPPER ALLOY

3. DESIGN - GEOMETRY:

- 3.1. THE 3-D CAD DATA IS BASIC (WITHOUT TOLERANCE) AND MASTER FOR THIS PART WITH EXCEPTION TO UNDERLINED DIMENSIONS. DIMENSIONAL INFORMATION NOT SHOWN ON THIS DRAWING IS DEFINED BY THE DATA FILE AT ITS LATEST REVISION.
- 3.2. PRODUCT DESIGN MODEL NUMBER(S): SEE BOM TABLE
- 3.3. GEOMETRIC DIMENSIONS AND TOLERANCES PER ASME Y14.5-2009
- 3.4. EDGES OF UNDEFINED SHAPE PER ISO 13715.
- 3.5. DIMENSIONS AND TOLERANCES APPLY BEFORE AND AFTER PLATING.
- 3.6. GENERAL TOLERANCES: SEE TITLE BLOCK

4. DESIGN - MANUFACTURING:

- 4.1. ANY REMAINING PROCESS LUBRICANT MUST NOT VARNISH OR DEGRADE ELECTRICAL PERFORMANCE. PROCESS LUBRICANTS SHOULD BE APPROVED BY THE RESPONSIBLE ENGINEER.
- 4.2. ALLOWABLE BURR: 0.03mm MAX UNLESS OTHERWISE SPECIFIED
- 4.3. FOR UNPLATES BLADES - TOOLING MARKS SPANNING ACROSS OR ALONG THE INTERFACING PROFILE OF THE BLADE SHOULD BE FURTHER INSPECTED. A TOOLING MARK DEEPER THAN 1 MICRON SHOULD NOT BE ACCEPTED.

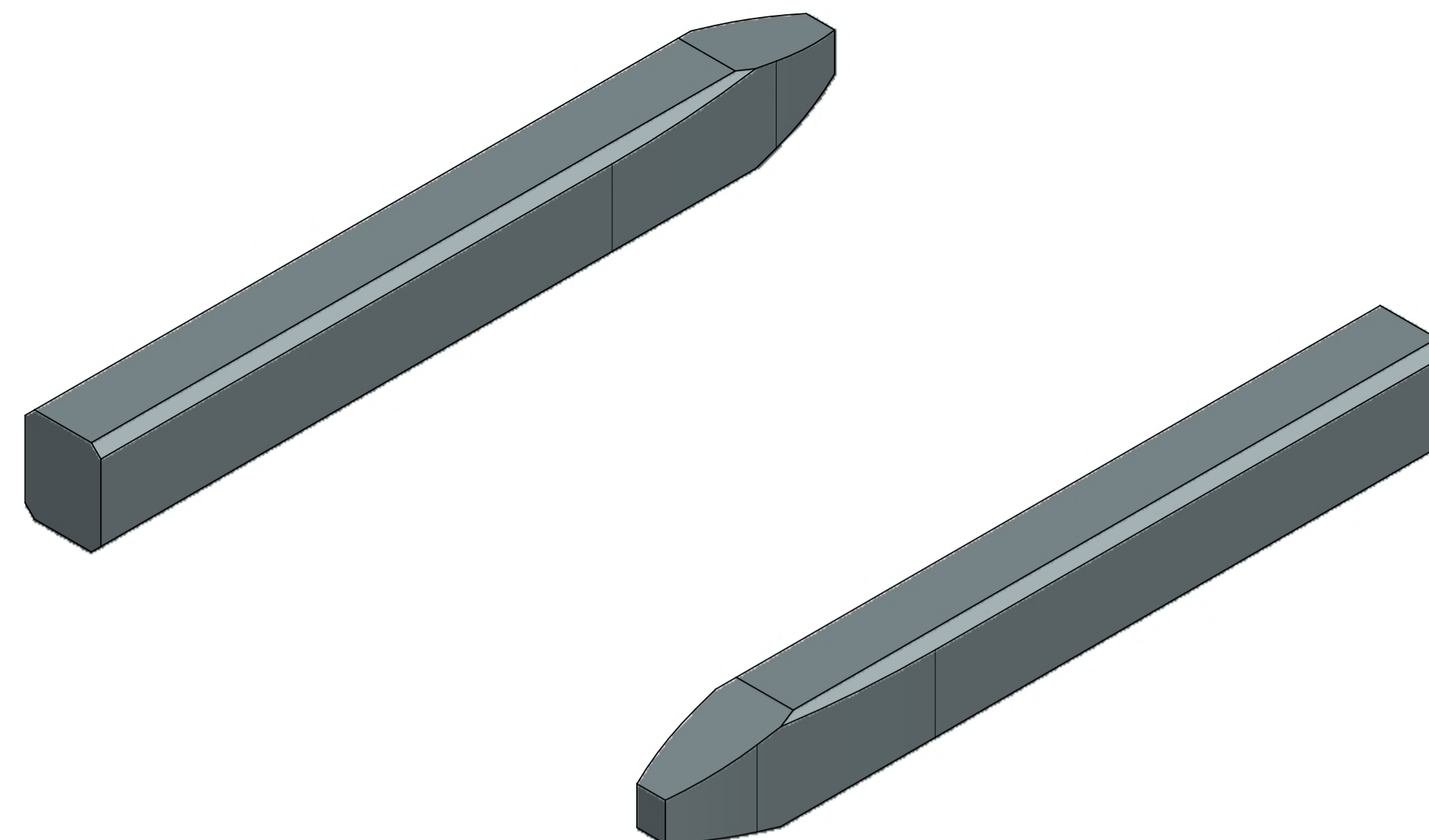

SCALE 50:1

0.5 MM PIN VIEW SHOWN FOR REPRESENTATION PURPOSES ONLY

THIS DRAWING CONTAINS INFORMATION THAT IS PROPRIETARY TO MOLEX ELECTRONIC TECHNOLOGIES, LLC AND SHOULD NOT BE USED WITHOUT WRITTEN PERMISSION										
FUNCTIONAL SYMBOLS	DIMENSION UNITS	SCALE	CURRENT REV DESC:							
	$\frac{F}{A} = 0$	mm	50:1	PHASE: Design Production						
DIVISIONAL SYMBOLS	GENERAL TOLERANCES (UNLESS SPECIFIED)		EC NO: CO-00000508							
	$\frac{F}{C} = 0$	ANGULAR TOL $\pm 0.5^\circ$		DRWN: Raghavendra MV 2022-01-31						
DIVISIONAL SYMBOLS	$\frac{F}{P} = 0$	4 PLACES	± 0.00000	CHK'D: Nathan Song 2022-02-07						
		3 PLACES	± 0.0150	APPR: Deepak Patil 2022-02-09						
		2 PLACES	± 0.050	INITIAL REVISION:						
		1 PLACE	± 0.10	DRWN: Raghavendra MV 2022-01-31						
	0 PLACES	± 0.00	APPR: Deepak Patil 2022-02-09							
DRAFT WHERE APPLICABLE MUST REMAIN WITHIN DIMENSIONS			THIRD ANGLE PROJECTION	DRAWING	SERIES	DOCUMENT NUMBER				
				A1-SIZE	34735	347350050		PSD	000	A21
						MATERIAL NUMBER	CUSTOMER		SHEET NUMBER	
									1 OF 2	

molex

DESIGN STANDARD
HEADER PIN & BLADE TIP GEOMETRY FOR MATING
TO HARNESS TERMINALS

PRODUCT SALES DRAWING

TABLE OF CONTENTS	
SHEET NO.	SHEET DESCRIPTION
1	NOTES AND BOM
2	CONFIGURATIONS
3	RECEPTACLE CONNECTOR ASSEMBLY

PART NUMBER AND MATING INTERFACE CHART						
PART NUMBER	KEY	COVER COLOR	TERMINAL POSITIONS PLUGGED	CPA INCLUDED	INTERFACE PART NUMBER	
349674001	A	BLACK	NONE	YES	349684801	
349674002	B	LIGHT GRAY	NONE	YES	349684802	
349674003	C	DARK GRAY	NONE	YES	349684803	
349674004	D	STONE GRAY	NONE	YES	349684804	
349674021	A	BLACK	2	YES	349684801	
349674005	A	BLACK	NONE	NO	349684801	
349674006	B	LIGHT GRAY	NONE	NO	349684802	
349674007	C	DARK GRAY	NONE	NO	349684803	
349674008	D	STONE GRAY	NONE	NO	349684804	
349674025	A	BLACK	2	NO	349684801	
349674051	A	BLACK	1, 2	YES	349684801	

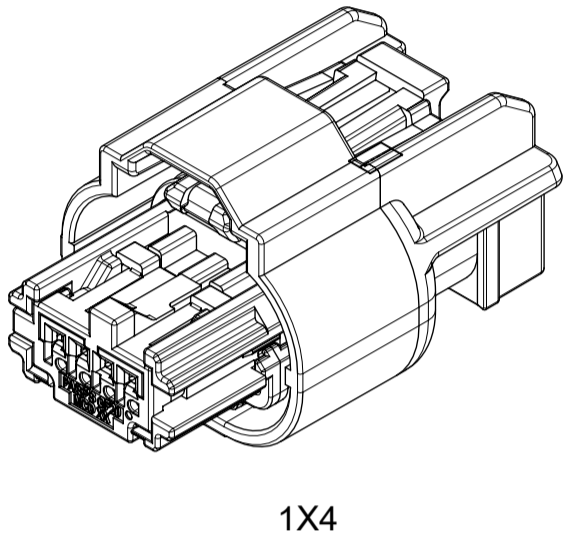

1X4

NOTES: VALID UNLESS OTHERWISE SPECIFIED

- GENERAL:
 - APPLICATION SPECIFICATION SEE: AS-34894-0001
-CONTAINS: PRODUCT INTRODUCTION, PRODUCT SUMMARY, CONNECTOR ASSEMBLY, PACKAGING INFORMATION, CONNECTOR MATING, SERVICE INSTRUCTIONS, ELECTRICAL CONTINUITY CHECKING, CRIMPING, AND TROUBLESHOOTING.
 - TERMINALS TO BE USED WITH THIS ASSEMBLY:
MOLEX CTX50 SEALED RECEPTACLE TERMINALS FOR INFORMATION ON TERMINALS SEE MOLEX DRAWING 349050400 AND TERMINAL PRODUCT SPECIFICATION PS-34905-001.
 - CONNECTOR PRODUCT SPECIFICATION SEE 349670001 PS
CONTAINS: PRODUCT INTRODUCTION, PRODUCT SUMMARY, RATINGS AND PRODUCT VALIDATION.
VALIDATED TO USCAR 2 REV 6.
RATINGS: T3 V1 S2
 - DESIGNED TO MATE WITH DEVICE INTERFACE AS SPECIFIED IN PART NUMBER AND INTERFACE CHART. SEE MOLEX DRAWING 349684800 FOR INTERFACE SPECIFICATION.
 - ASSEMBLY SHIPPED WITH ISL IN PRE-LOCK POSITION (SEE ISL PRE-LOCK VIEW SHEET 3).
 - PACKAGING SPECIFICATION PER MOLEX DRAWING: PK-31301-898
 - PARTS MUST BE IN COMPLIANCE TO MOLEX CHEMICAL SUBSTANCES FOR PRODUCTS AND PACKAGING SPECIFICATION: ES-40000-5016
 - DATA MUST BE SUBMITTED UNDER THE MOLEX PART NUMBER TO IMDS (COMPANY ID#13255)
- DESIGN - MATERIALS:
 - CONNECTOR HOUSING: SPS/NYLON GF20 BLACK
 - TERMINAL HOUSING: SPS/NYLON GF20 BLACK
 - COVER: SPS/NYLON GF20 COLORS IN PART NUMBER CHART
 - ISL: SPS GF30 NATURAL
 - MAT SEAL: INHERENTLY LUBRICATED SILICONE LIGHT BLUE
 - RING SEAL: INHERENTLY LUBRICATED SILICONE RUST RED
 - CPA (OPTIONAL): PBT GF30 RED
- DESIGN - GEOMETRY:
 - ALL GRAPHIC DATA IS BASIC (NO TOLERANCE) AND MUST BE TAKEN FROM THE DATA FILE AT ITS LATEST REVISION.
 - GEOMETRIC DIMENSIONS AND TOLERANCES PER ASME Y14.5M-2009
 - EDGES AND UNDIMENSIONED DETAILS PER ISO13715
 - CORNERS SHOWN AS SHARP TO BE R 0.2 MAX.
 - LETTERING SHALL BE 0.15 MAX RAISED IN 0.25 MAX RECESS PAD.
THIS INCLUDES RECYCLING CODE, CAVITY ID, VENDOR IDENTIFICATION, AND CUSTOMER MATERIAL NUMBER.
 - VISUAL DEFECTS SHALL MEET COSMETIC STANDARD PS-45499-002 (Class B).
 - PARTS ARE LASER MARKED WITH PART NUMBER AND DATE CODE
 - FOR HAND CLEARANCES REQUIRED FOR MATING THE CONNECTOR, REFER TO USCAR 25-3 SECTION 8/8.2 FOR HAND PLUG CONNECTORS.

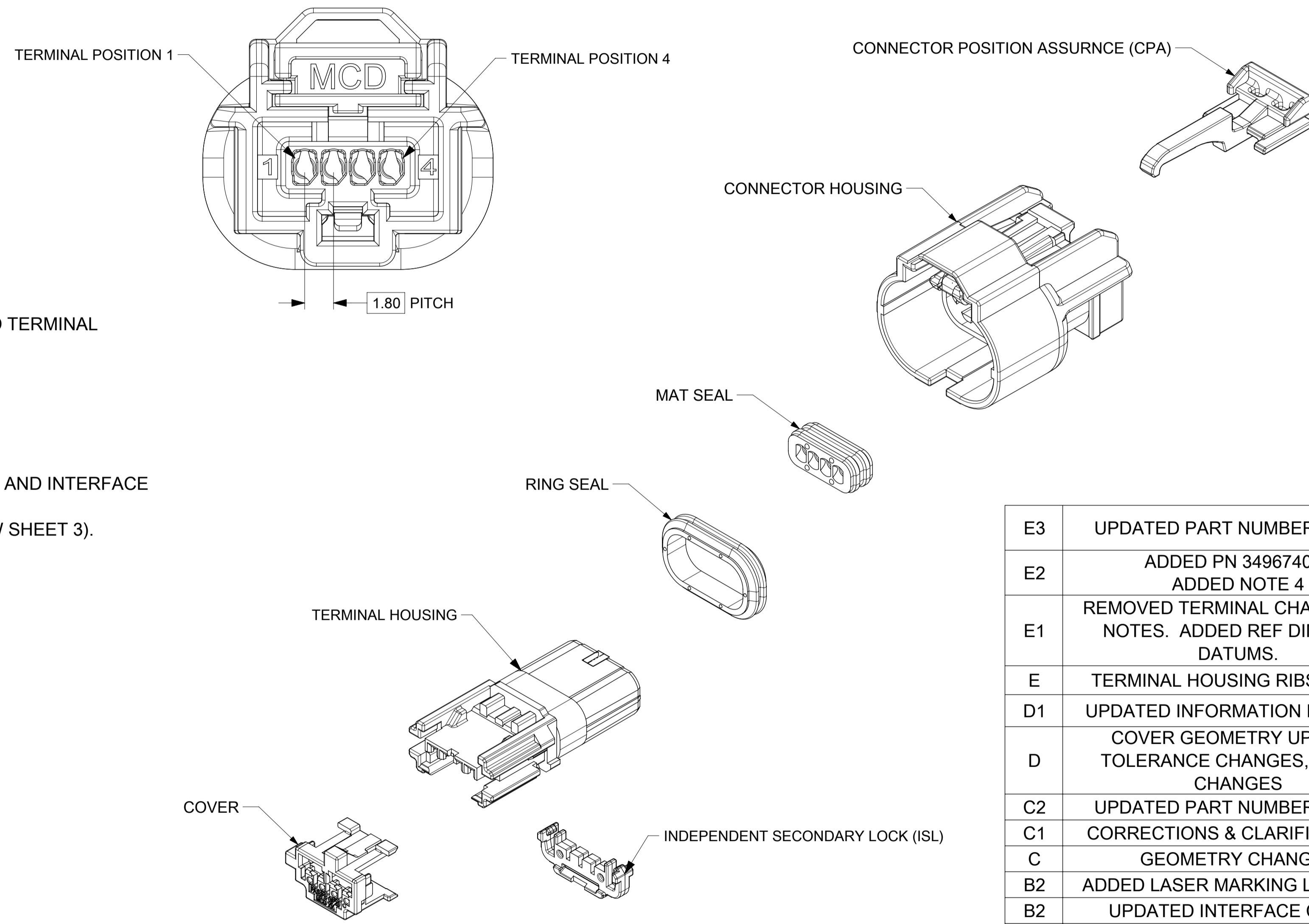

E3	UPDATED PART NUMBER CHART
E2	ADDED PN 349674051 ADDED NOTE 4
E1	REMOVED TERMINAL CHART FROM NOTES. ADDED REF DIM TO ID DATUMS.
E	TERMINAL HOUSING RIBS ADDED
D1	UPDATED INFORMATION IN NOTES
D	COVER GEOMETRY UPDATE, TOLERANCE CHANGES, NOTES CHANGES
C2	UPDATED PART NUMBER CHART
C1	CORRECTIONS & CLARIFICATIONS
C	GEOMETRY CHANGES
B2	ADDED LASER MARKING LOCATION
B1	UPDATED INTERFACE CHART
B	COMPONENT MODEL UPDATE
A1	UPDATED VIEWS & INTERFACE CHART
A	MINOR UPDATES
1	INITIAL RELEASE
REV	REV DESCRIPTION

INSPECTION NUMBER LOG	
LAST NUMBER:	15
ADDED:	2,4,7,8,9,13,14

FUNCTIONAL SYMBOLS	THIS DRAWING CONTAINS INFORMATION THAT IS PROPRIETARY TO MOLEX ELECTRONIC TECHNOLOGIES, LLC AND SHOULD NOT BE USED WITHOUT WRITTEN PERMISSION				
	$\frac{E}{A} = 0$ $\frac{E}{C} = 0$ $\frac{E}{P} = 0$	DIMENSION UNITS: mm SCALE: 1:1 GENERAL TOLERANCES (UNLESS SPECIFIED) ANGULAR TOL: $\pm 3.0^\circ$			CURRENT REV DESC: UPDATED PART NUMBER CHART EC NO: 656180 DRWN: MLI149 CHK'D: JCONDON APPR: JCONDON
DIVISIONAL SYMBOLS	4 PLACES: \pm 3 PLACES: \pm 2 PLACES: ± 0.1 1 PLACE: ± 0.2 0 PLACES: \pm	INITIAL REVISION: DRWN: MNS02 APPR: KDEKOSKI	2016/04/26 2016/05/19	PRODUCT CUSTOMER DRAWING DOCUMENT NUMBER: 349674000 DOC TYPE: PSD DOC PART: 000 REVISION: E3	
DRAFT WHERE APPLICABLE MUST REMAIN WITHIN DIMENSIONS		THIRD ANGLE PROJECTION	DRAWING: A1-SIZE SERIES: 34967	MATERIAL NUMBER: SEE CHART CUSTOMER:	SHEET NUMBER: 1 OF 3

SHEET DESCRIPTION

KEY CONFIGURATIONS

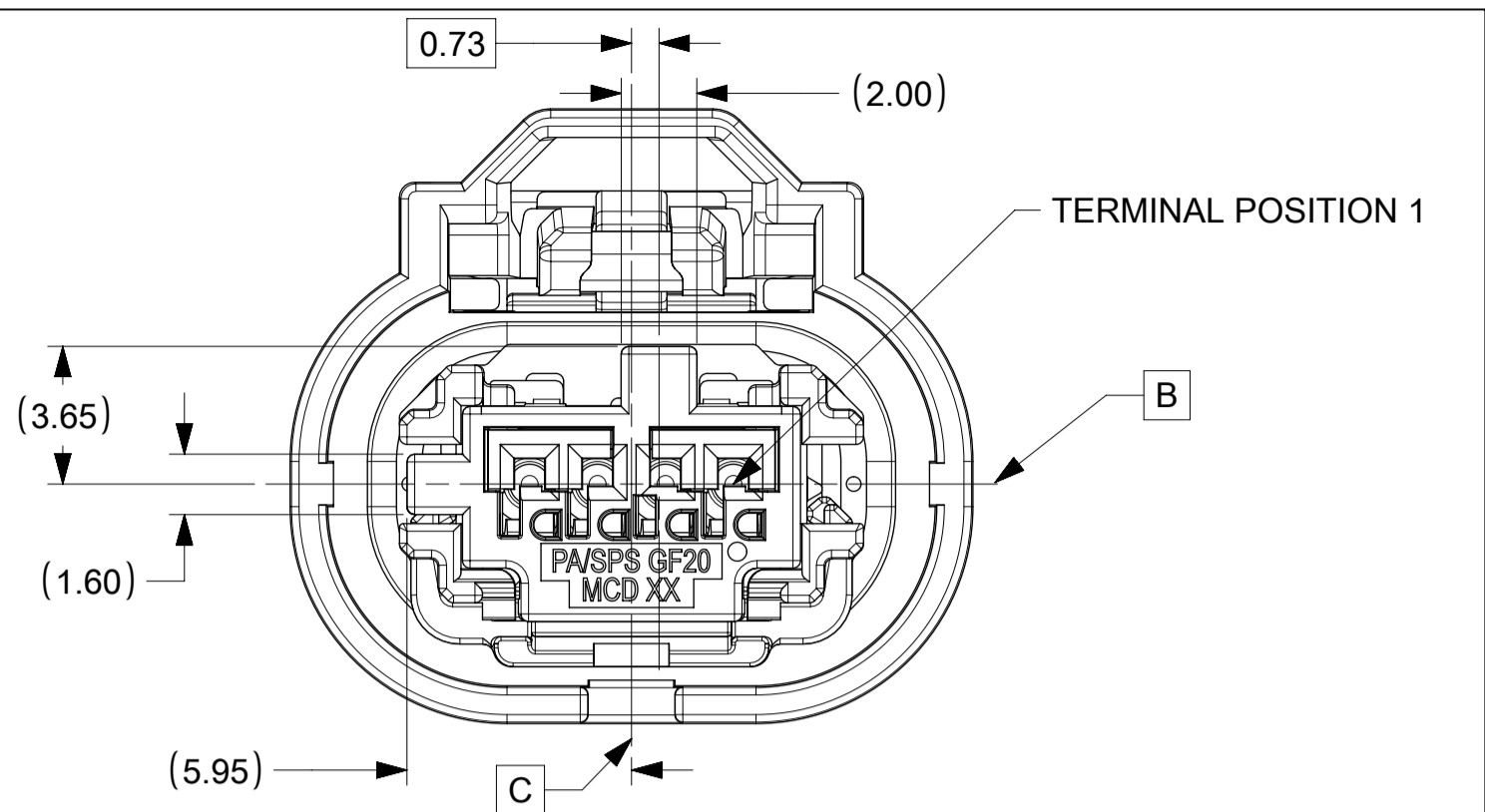

KEY A

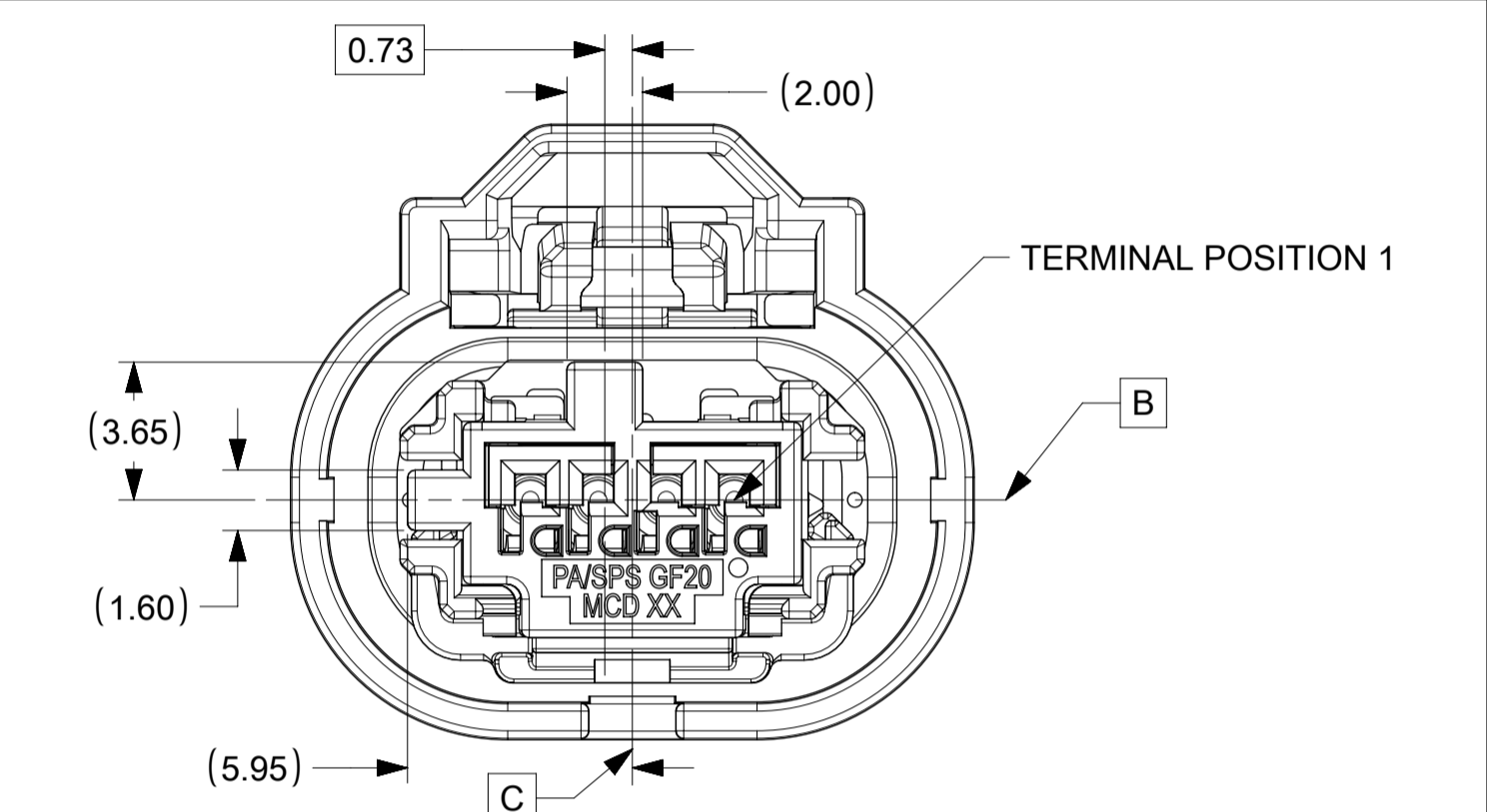

KEY B

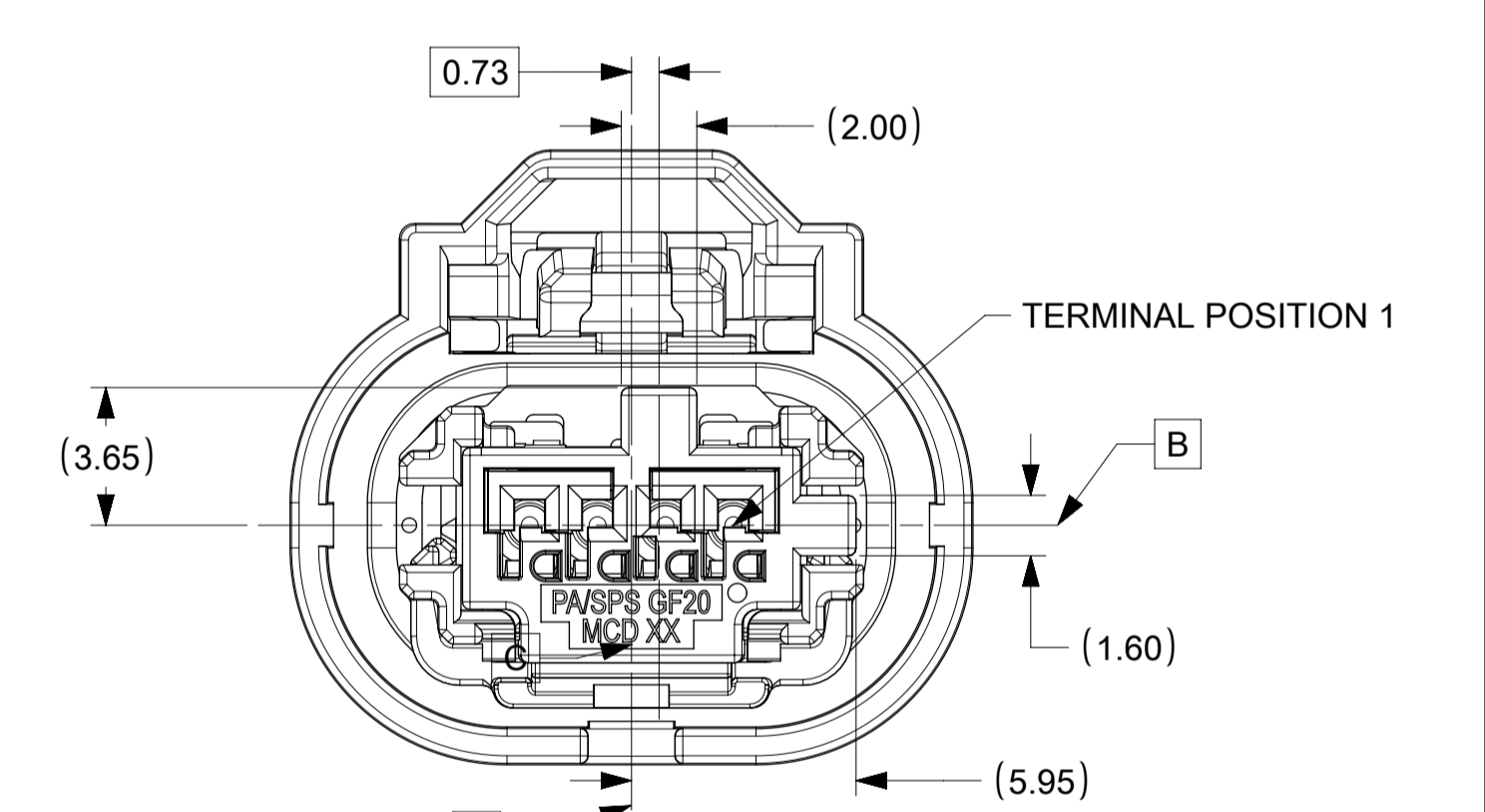

KEY C

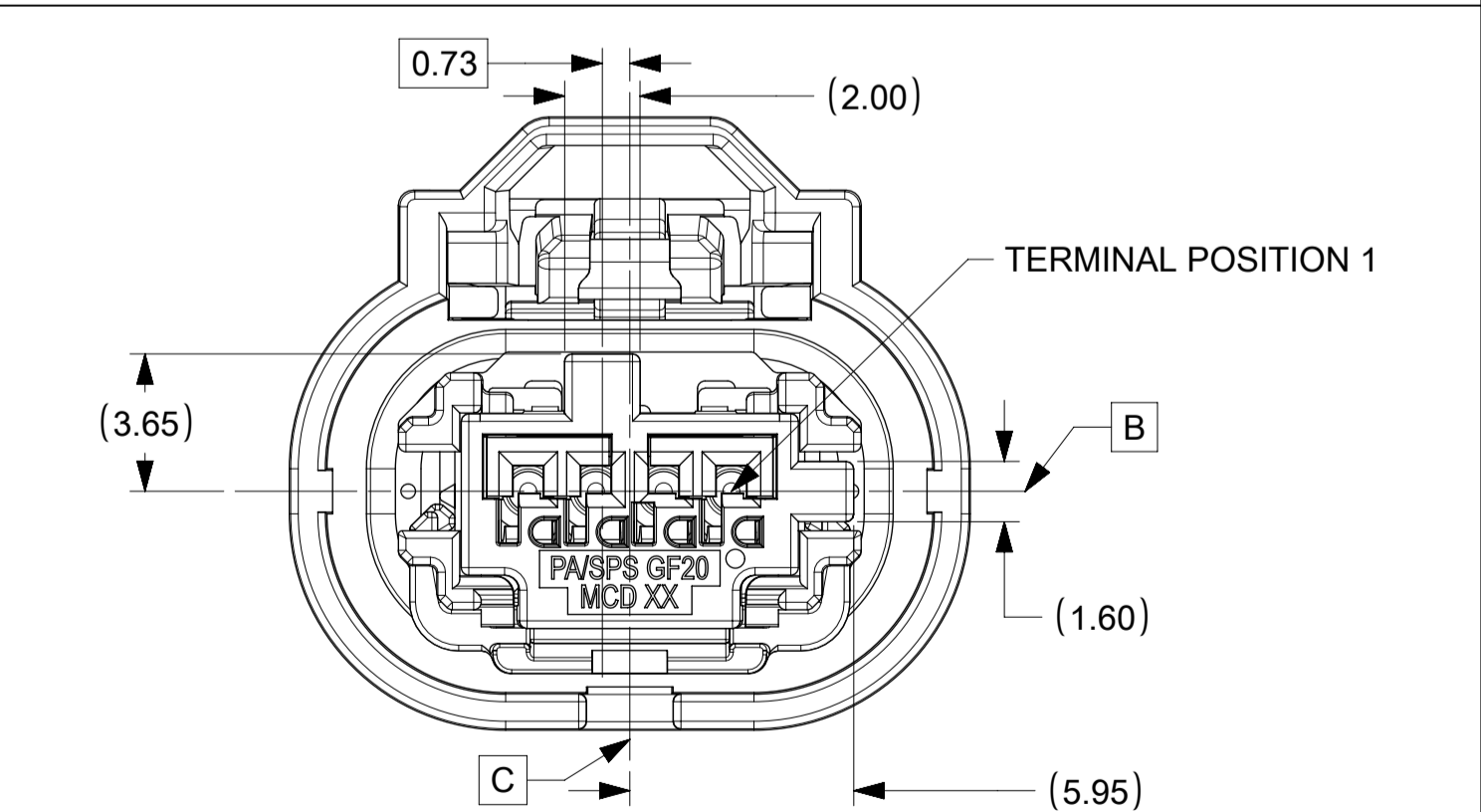

KEY D

FUNCTIONAL SYMBOLS	THIS DRAWING CONTAINS INFORMATION THAT IS PROPRIETARY TO MOLEX ELECTRONIC TECHNOLOGIES, LLC AND SHOULD NOT BE USED WITHOUT WRITTEN PERMISSION		CURRENT REV DESC: UPDATED PART NUMBER CHART		molex
	DIMENSION UNITS	SCALE			
$\frac{E}{A} = 0$	mm	1:1			MINI50 SEALED 1X4 RCPT ASSY
$\frac{E}{C} = 0$	GENERAL TOLERANCES (UNLESS SPECIFIED)				
$\frac{E}{P} = 0$	ANGULAR TOL ± 3.0°				PRODUCT CUSTOMER DRAWING
DIVISIONAL SYMBOLS	4 PLACES	±	EC NO: 656180	2021/02/19	
	3 PLACES	±	DRWN: MLI149	2021/02/22	
	2 PLACES	± 0.1	CHK'D: JCONDON	2021/02/22	
	1 PLACE	± 0.2	APPR: JCONDON	2021/02/22	
0 PLACES	±	INITIAL REVISION:			
DRAFT WHERE APPLICABLE MUST REMAIN WITHIN DIMENSIONS		THIRD ANGLE PROJECTION	DRWN: MNS02	2016/04/26	DOCUMENT NUMBER
			APPR: KDEKOSKI	2016/05/19	349674000
					DOC TYPE DOC PART REVISION
					PSD 000 E3
			DRAWING	SERIES	MATERIAL NUMBER
			A1-SIZE	34967	SEE CHART
					CUSTOMER
					SHEET NUMBER
					2 OF 3

SHEET DESCRIPTION
RECEPTACLE CONNECTOR ASSEMBLY

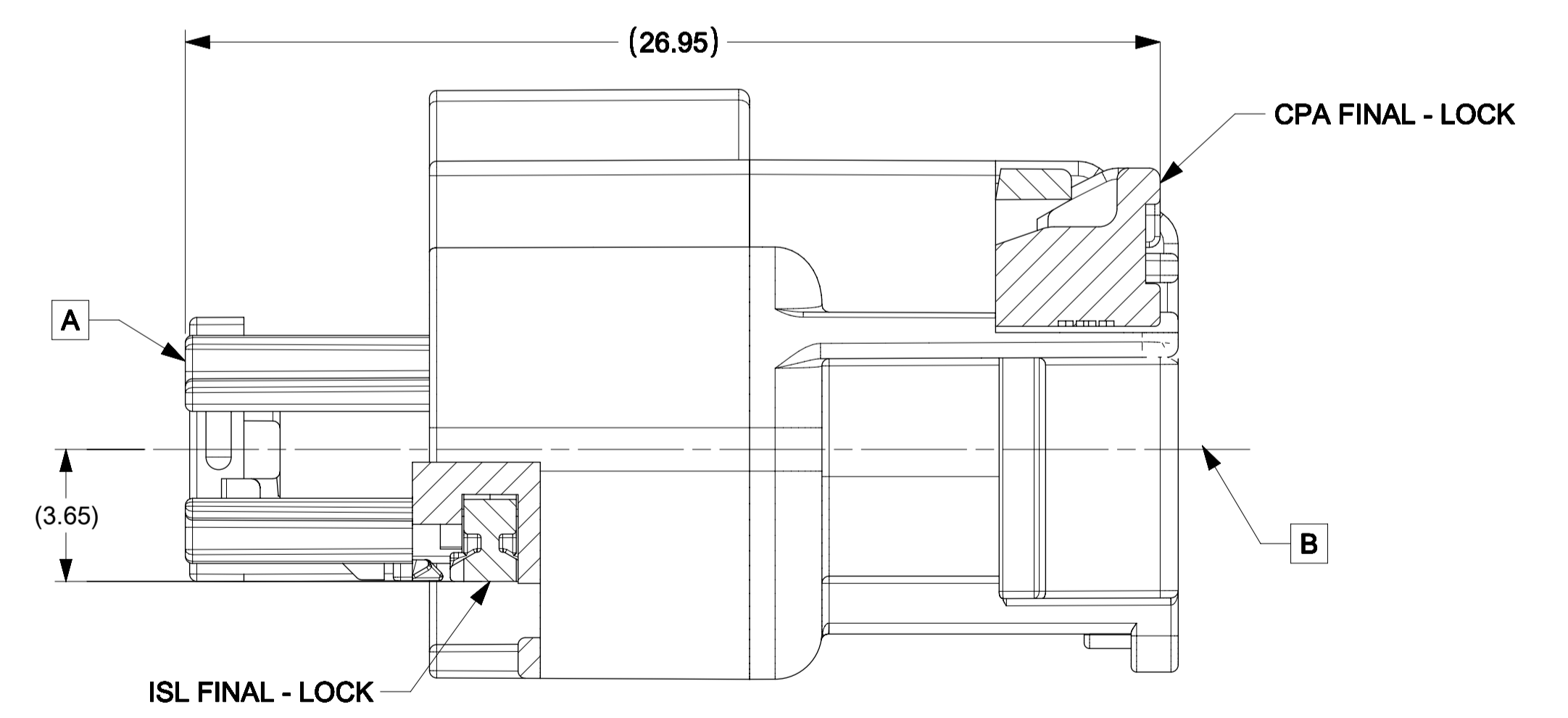
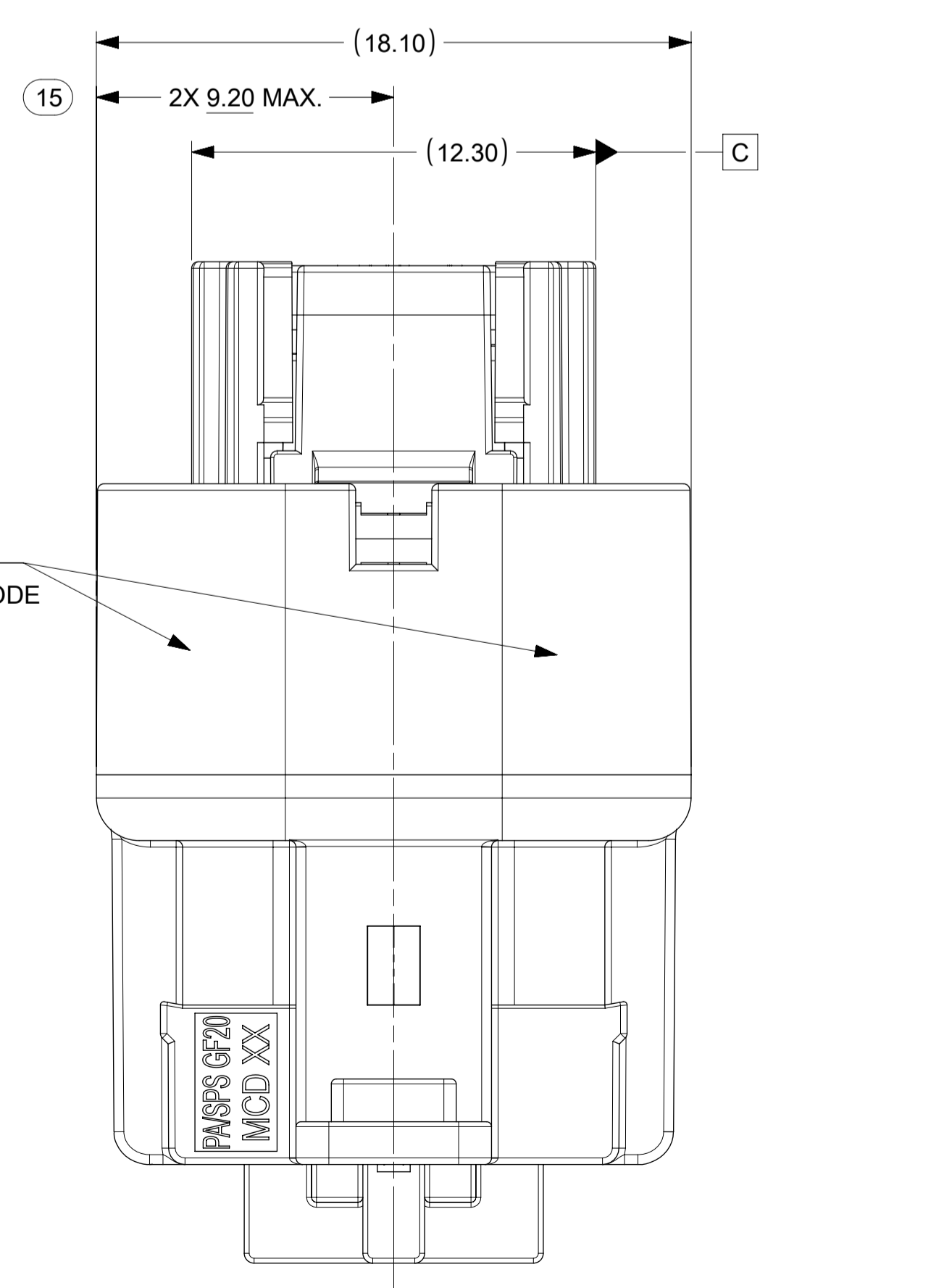
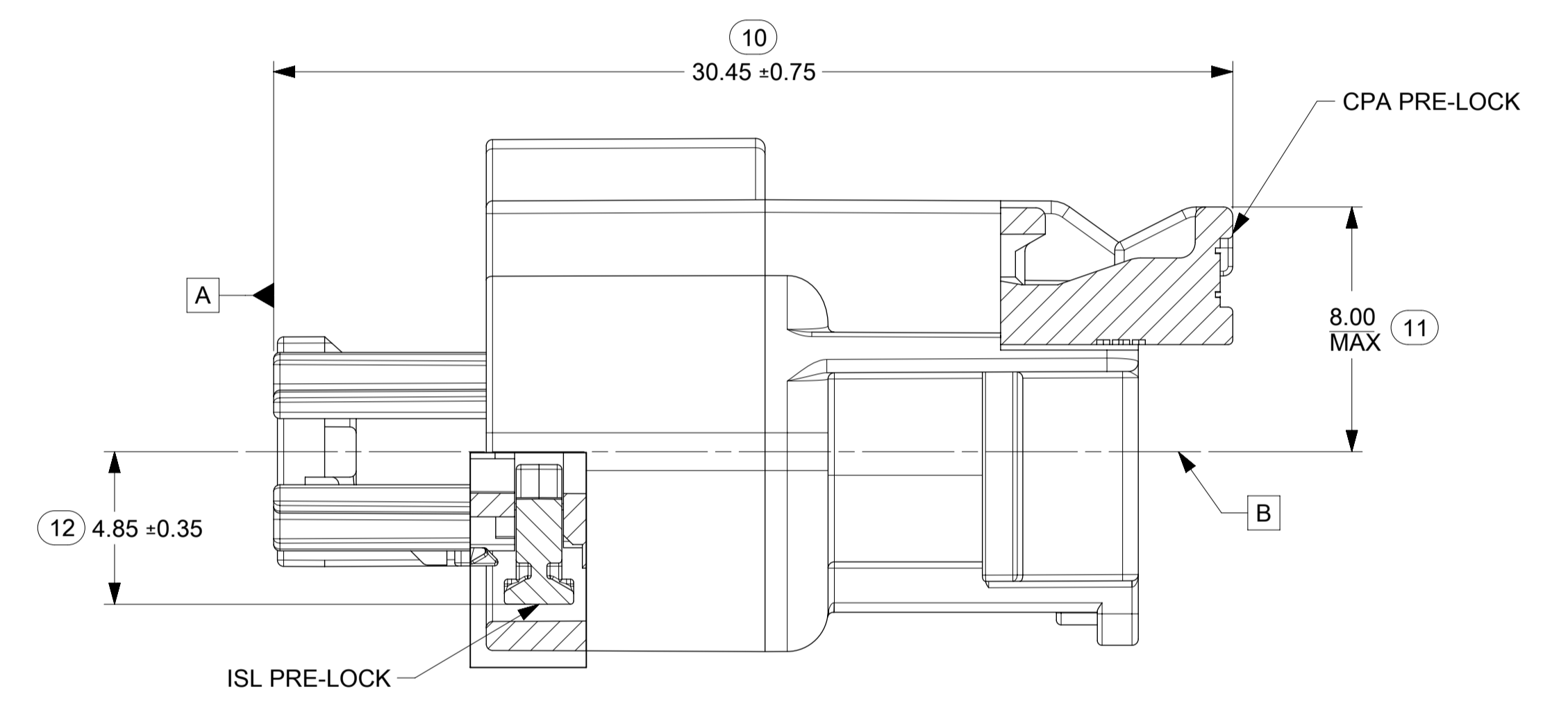
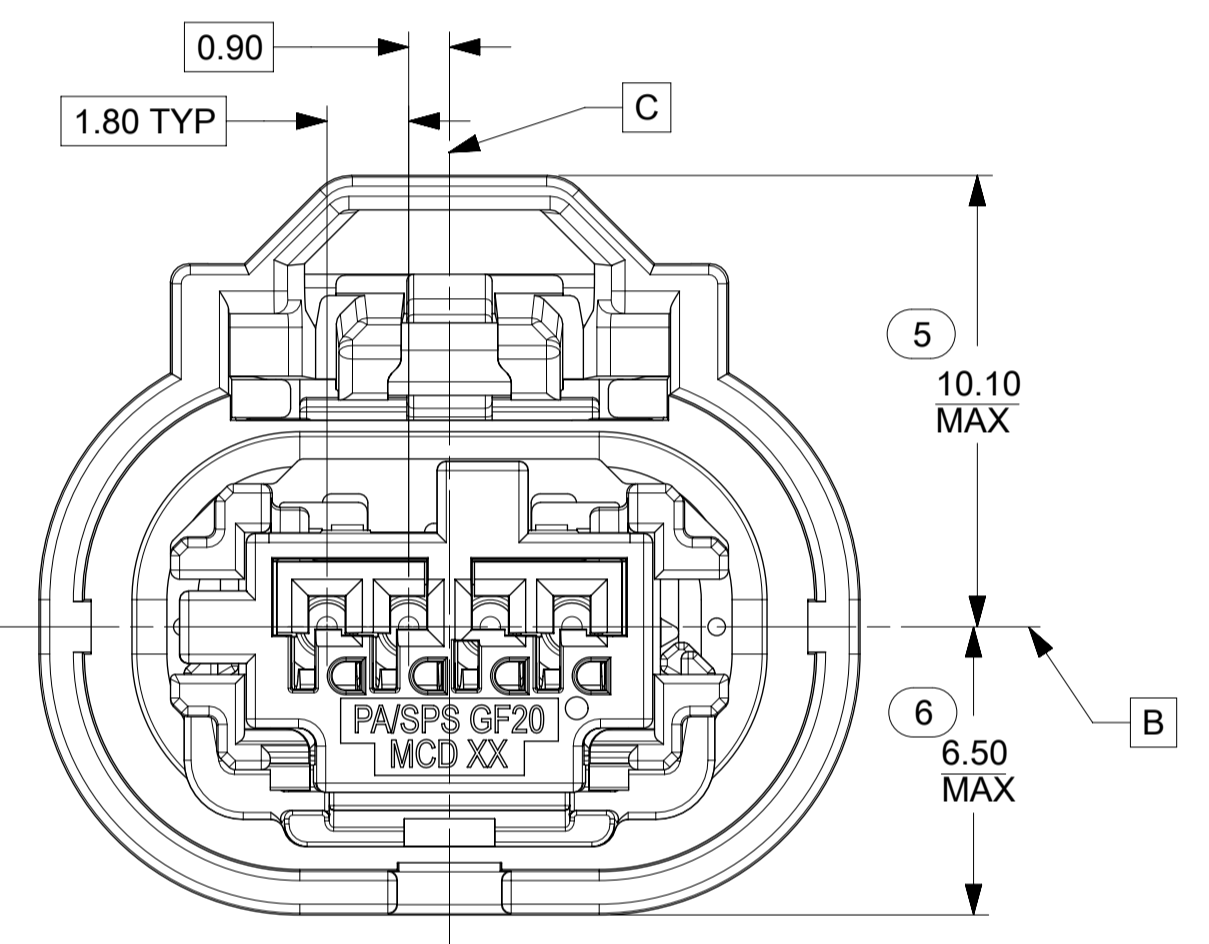
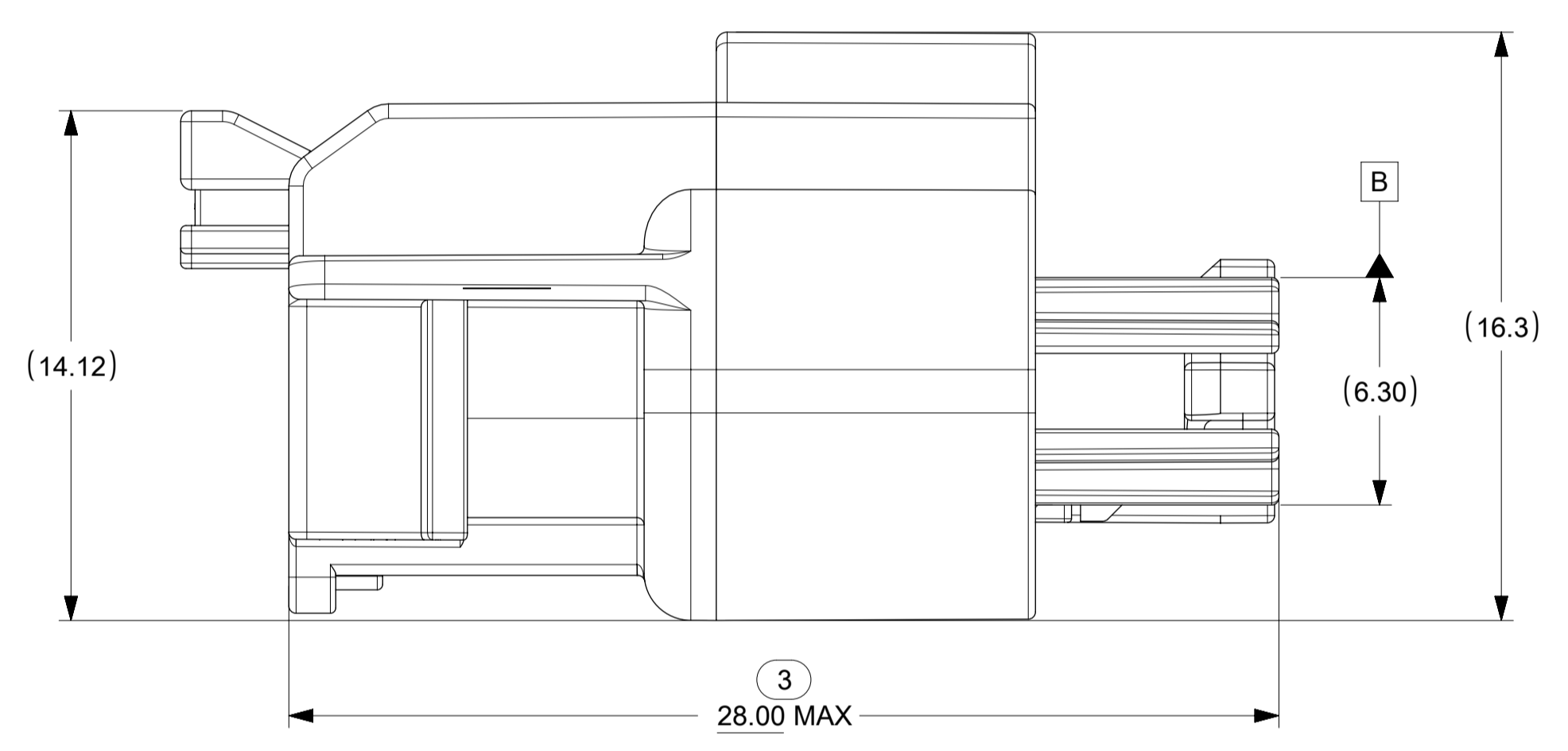
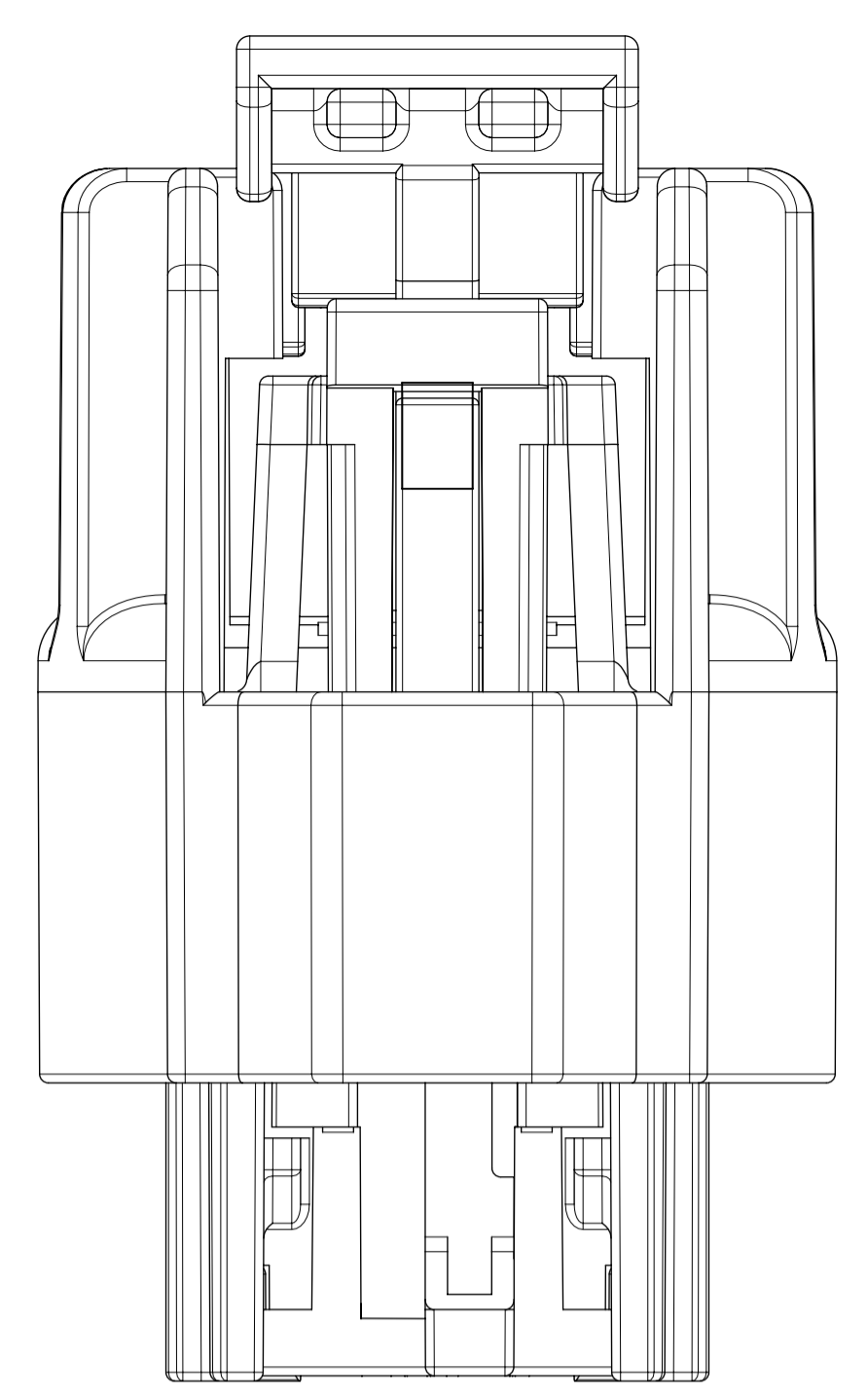
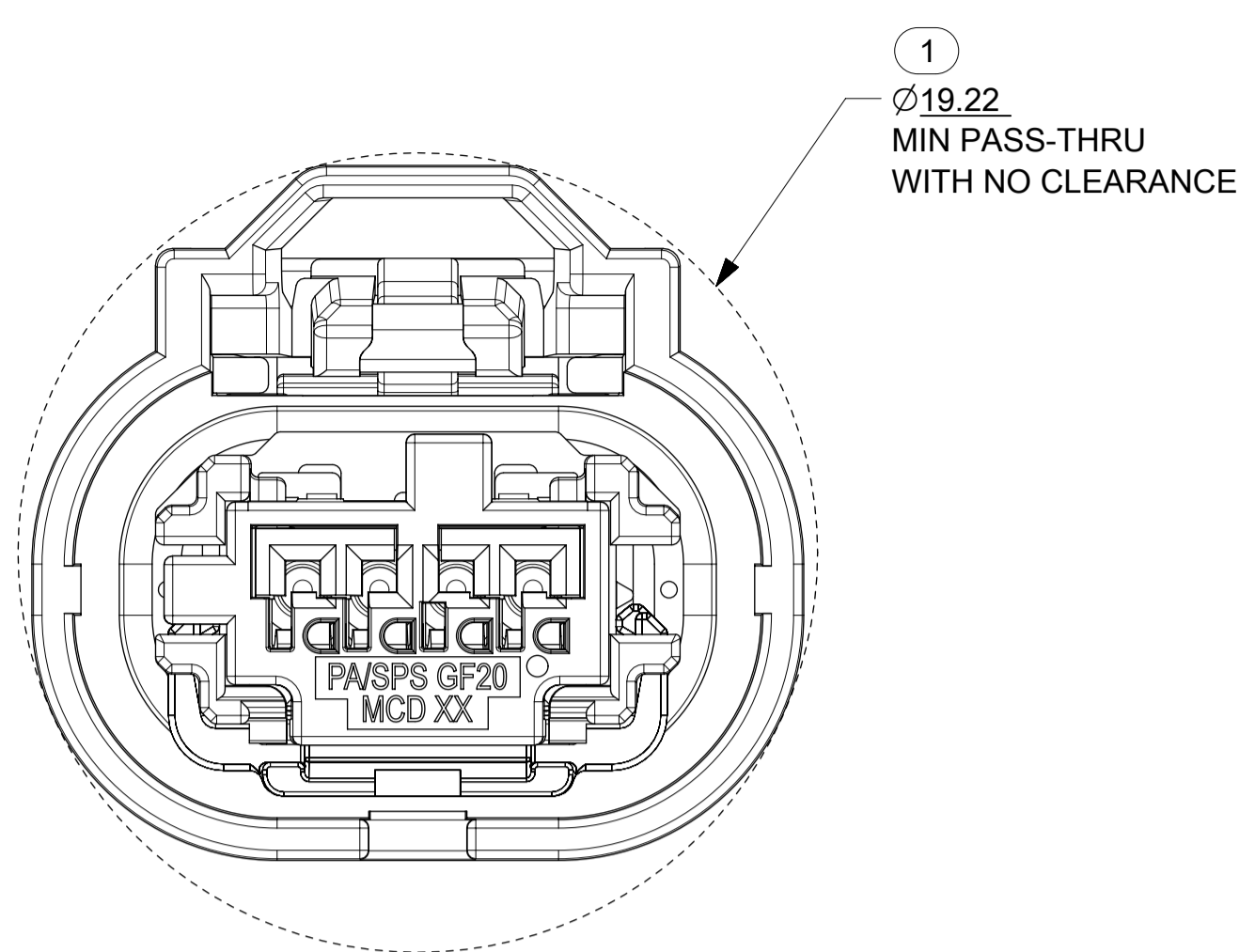

FUNCTIONAL SYMBOLS	THIS DRAWING CONTAINS INFORMATION THAT IS PROPRIETARY TO MOLEX ELECTRONIC TECHNOLOGIES, LLC AND SHOULD NOT BE USED WITHOUT WRITTEN PERMISSION		CURRENT REV DESC: UPDATED PART NUMBER CHART				
	DIMENSION UNITS	SCALE					
$\frac{E}{A} = 0$	mm	1:1	GENERAL TOLERANCES (UNLESS SPECIFIED)		MINI50 SEALED 1X4 RCPT ASSY PRODUCT CUSTOMER DRAWING		
$\frac{E}{C} = 0$	4 PLACES ±						
$\frac{E}{P} = 0$	3 PLACES ±		ANGULAR TOL ± 3.0°		DOCUMENT NUMBER: 349674000 DOC TYPE: PSD DOC PART: 000 REVISION: E3		
DIVISIONAL SYMBOLS		2 PLACES ± 0.1					
		1 PLACE ± 0.2		EC NO: 656180 DRWN: MLI149 CHK'D: JCONDON APPR: JCONDON INITIAL REVISION: DRWN: MNS02 APPR: KDEKOSKI		2021/02/19 2021/02/22 2021/02/22	
		0 PLACES ±					
DRAFT WHERE APPLICABLE MUST REMAIN WITHIN DIMENSIONS		THIRD ANGLE PROJECTION	DRAWING	SERIES	MATERIAL NUMBER	CUSTOMER	SHEET NUMBER
			A1-SIZE	34967	SEE CHART		3 OF 3

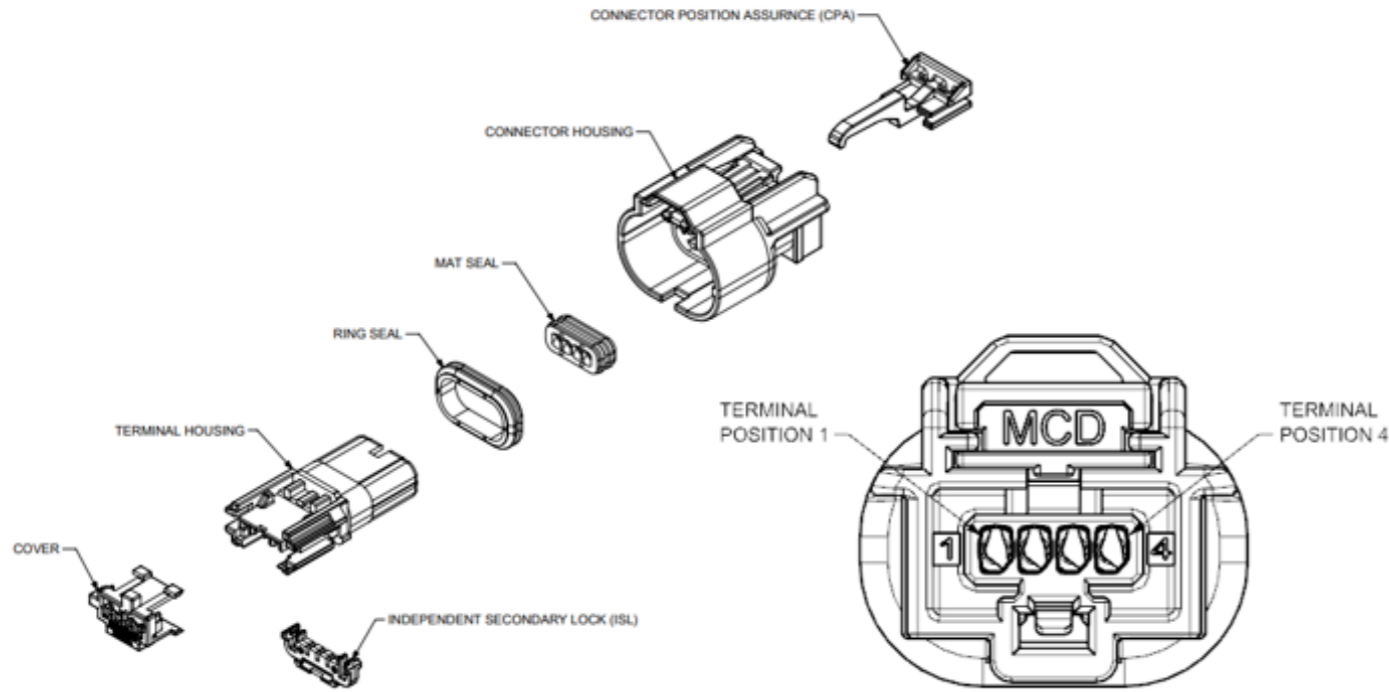

ABBREVIATION	DESCRIPTION	COLOR	MATERIAL
A-BLACK	COVER KEYING OPTION A	BLACK	SPS/NYLON GF20, 25% MAX REGRIND
B-LIGHT GRAY	COVER KEYING OPTION B	LIGHT GRAY	SPS/NYLON GF20, 25% MAX REGRIND
C-DARK GRAY	COVER KEYING OPTION C	DARK GRAY	SPS/NYLON GF20, 25% MAX REGRIND
D-STONE GRAY	COVER KEYING OPTION D	STONE GRAY	SPS/NYLON GF20, 25% MAX REGRIND
C-HSG-P	CONNECTOR HOUSING PLUGED, W/ BRIDGE	BLACK	SPS/NYLON GF20, 25% MAX REGRIND
C-HSG-O	CONNECTOR HOUSING OPEN, W/ BRIDGE	BLACK	SPS/NYLON GF20, 25% MAX REGRIND
T-HSG	TERMINAL HOUSING	BLACK	SPS/NYLON GF20, 25% MAX REGRIND
ISL	INDEPENDENT SECONDARY LOCK	NATURAL	SPS GF 30, 25% MAX REGRIND
CPA	CONNECTOR POSITION ASSURANCE	RED	PBT GF 30, 25% MAX REGRIND
M	MAT SEAL	LIGHT BLUE	NHERENTLY LUBRICATED SILICONE
R	RING SEAL	RUST RED	INHERENTLY LUBRICATED SILICONE

FOR ADDITIONAL INFORMATION SEE 1x4 - 349674000/PSD

ASSEMBLY DESCRIPTION	ASSEMBLY PART NUMBER	COMPONENT							BLOCKED TERMINALS				STATUS	COMMENTS	OPTIONAL ATTACHMENTS SOLD SEPERATELY
		THE PRESENCE OF AN ABBREVIATION INDICATES THE PRESENCE OF THAT COMPONENT							CAVITY WITH A NUMBER INDICATES BLOCKED TERMINAL POSITION CAVITY WITHOUT A NUMBER INDICATES OPEN TERMINAL POSITION						BLACKSHELL P/N
		COVER KEY/ COLOR	CONNECTOR HOUSING	TERMINAL HOUSING	ISL	CPA	MAT SEAL	RING SEAL							
MINI50 SEALED 1X4 RCPT CONN KEY A CPA	349674001	A-BLACK	C-HSG-O	T-HSG	ISL	YES	M	R	-	-	-	-	SALEABLE		2130885410
MINI50 SEALED 1X4 RCPT CONN KEY B CPA	349674002	B-LIGHT GRAY	C-HSG-O	T-HSG	ISL	YES	M	R	-	-	-	-	SALEABLE		2130885410
MINI50 SEALED 1X4 RCPT CONN KEY C CPA	349674003	C-DARK GRAY	C-HSG-O	T-HSG	ISL	YES	M	R	-	-	-	-	SALEABLE		2130885410
MINI50 SEALED 1X4 RCPT CONN KEY D CPA	349674004	D-STONE GRAY	C-HSG-O	T-HSG	ISL	YES	M	R	-	-	-	-	SALEABLE		2130885410
MINI50 SEALED 1X4 RCPT CONN KEY A CPA	349674005	A-BLACK	C-HSG-O	T-HSG	ISL	NO	M	R	-	-	-	-	SALEABLE		2130885410
MINI50 SEALED 1X4 RCPT CONN KEY B CPA	349674006	B-LIGHT GRAY	C-HSG-O	T-HSG	ISL	NO	M	R	-	-	-	-	SALEABLE		2130885410
MINI50 SEALED 1X4 RCPT CONN KEY C CPA	349674007	C-DARK GRAY	C-HSG-O	T-HSG	ISL	NO	M	R	-	-	-	-	SALEABLE		2130885410
MINI50 SEALED 1X4 RCPT CONN KEY D CPA	349674008	D-STONE GRAY	C-HSG-O	T-HSG	ISL	NO	M	R	-	-	-	-	SALEABLE		2130885410
MINI50 SEALED 1X4 RCPT CONN KEY A CPA/1	349674021	A-BLACK	C-HSG-P	T-HSG	ISL	YES	M	R	-	2	-	-	SALEABLE		2130885410
MINI50 SEALED 1X4 RCPT CONN KEY A CPA/1	349674025	A-BLACK	C-HSG-P	T-HSG	ISL	NO	M	R	-	2	-	-	SALEABLE		2130885410

ASSEMBLY DESCRIPTION	ASSEMBLY PART NUMBER	COMPONENT							BLOCKED TERMINALS				STATUS	COMMENTS	OPTIONAL ATTACHMENTS SOLD SEPERATELY
		THE PRESENCE OF AN ABBREVIATION INDICATES THE PRESENCE OF THAT COMPONENT							CAVITY WITH A NUMBER INDICATES BLOCKED TERMINAL POSITION CAVITY WITHOUT A NUMBER INDICATES OPEN TERMINAL POSITION						BLACKSHELL P/N
		COVER KEY/ COLOR	CONNECTOR HOUSING	TERMINAL HOUSING	ISL	CPA	MAT SEAL	RING SEAL							
MINI50 SEALED 1X4 RCPT CONN KEY A CPA/2	349674051	A-BLACK	C-HSG-P	T-HSG	ISL	YES	M	R	1	2	-	-	SALEABLE		2130885410
MINI50 SEALED 1X4 RCPT CON KEY A/2	349674052	A-BLACK	C-HSG-P	T-HSG	ISL	NO	M	R	1	2	-	-	SALEABLE		2130885410

TABLE OF CONTENTS	
SHEET NO.	SHEET DESCRIPTION
1	INTERFACE NOTES AND BOM
2	INTERFACE KEY CONFIGURATIONS
3	INTERFACE DEFINITION
4	INTERFACE DATUM TARGETS

MATING INTERFACE CHART			
DESCRIPTION	COLOR	MODEL NUMBER	KEY
1x4, KEY A, BLACK	BLACK	349684801	A
1x4, KEY B, LIGHT GRAY	LIGHT GRAY	349684802	B
1x4, KEY C, DARK GRAY	DARK GRAY	349684803	C
1x4, KEY D, STONE GRAY	STONE GRAY	349684804	D

NOTES: VALID UNLESS OTHERWISE SPECIFIED

1. GENERAL:

REFER TO "SAE/USCAR 12 CONNECTOR GUIDELINES" AND "SAE/USCAR 2 PERFORMANCE SPECIFICATION FOR AUTOMOTIVE ELECTRICAL CONNECTOR SYSTEMS" FOR ADDITIONAL REQUIREMENTS.

2. DESIGN - MATERIALS:

- a. HOUSING: SPS/NYLON 20% GLASS FILLED OR EQUIVALENT
FLAMMABILITY REQUIREMENT: PER ISO3795 OR GM3191
 - 1. BURN RATE 100mm/MIN MAXIMUM
 - 2. MATERIAL MUST BE SELF EXTINGUISHING
- b. BLADE TERMINAL: SEE MOLEX SALES DRAWING 347350050. FOR MATERIAL, DIMENSIONAL, PLATING AND COATING REQUIREMENTS AND ANY BLADE TERMINAL DESIGN INFORMATION NOT SHOWN ON REFERENCED OR THIS DRAWING SEE EWCAP DWG NO. EWCAP-001.
 - 1. TIN PLATING: 2.5-4.0 MICROMETERS MATTE TIN OVER 1.25-2.25 MICROMETERS DUCTILE SULFAMATE NICKEL
 - 2. SILVER PLATING: 1.9-3.3 MICROMETERS SILVER OVER 1.0-1.8 MICROMETERS DUCTILE SULFAMATE NICKEL.
ANTI-TARNISH: SYNTHETIC HYDROCARBON CONTACT SURFACE FINISH OR EQUIVALENT APPLIED WITHOUT VOID TO CONTACT AREA

c. STANDARD COLORS FOR KEYING (SEE CHART). DEVIATION REQUIRES APPROVAL OF AUTHORIZED PERSON.

3. DESIGN - GEOMETRY:

- a. THE 3-D CAD DATA IS BASIC (WITHOUT TOLERANCE) AND THE MASTER FOR THIS PART WITH THE EXCEPTION OF UNDERLINED DIMENSIONS. DIMENSIONAL INFORMATION NOT SHOWN IN THIS DRAWING IS DEFINED BY THE DATA FILE AT ITS LATEST REVISION.
- b. PRODUCT DESIGN MODEL NUMBER(S): SEE MATING INTERFACE CHART
- c. GEOMETRIC DIMENSIONS AND TOLERANCES PER ASME Y14.5M - 2009
- d. GENERAL TOLERANCES: SEE TITLE BLOCK
- e. EDGES AND UNDIMENSIONED DETAILS PER ISO13715
- f. CORNERS SHOWN AS SHARP TO BE R 0.2 MAX.
- g. LETTERING SHALL BE 0.15 MAX RAISED IN 0.25 MAX RECESS PAD.
THIS INCLUDES RECYCLING CODE, CAVITY ID, VENDOR IDENTIFICATION, AND CUSTOMER MATERIAL NUMBER.
(FOR SMALL PARTS: LETTERING SHALL BE 0.10 MAX RAISED IN 0.15 MAX RECESS PAD)

4. DESIGN - MANUFACTURING:

- a. ALLOWABLE FLASH MAX 0.20 HIGH BY MAX 0.13 THICK.
- b. ALLOWABLE SPLIT/PARTING LINE MISMATCH 0.2 MAX.
- c. EJECTOR PIN MARKS TO BE FLUSH TO 0.25 MAX DEPRESSED. LOCATION MUST BE APPROVED BY PRODUCT ENGINEERING. EJECTOR PIN MARKS NOT PERMISSIBLE ON OR NEAR DATUM TARGET AREA.
- d. ALLOWABLE GATE VESTIGE FLUSH TO 0.25 MAX RECESS. LOCATION MUST BE APPROVED BY PRODUCT ENGINEERING.
- e. NO EXTERNAL MOLD RELEASE AGENT ALLOWED DURING MANUFACTURING.
- f. NO PARTING LINES, MISMATCHES OR EJECTOR MARKS PERMISSIBLE WITHIN THE INDICATED SURFACE. TOOLING FOR INDICATED SURFACE MUST BE PROCESSED TO A SURFACE FINISH OF NTMA #70 (400 PAPER).
- g. BLADE TERMINAL ENVIRONMENTAL BARRIER (USED WITH SILVER PLATED TERMINALS) SHALL NOT BE PRESENT ON ANY SURFACE OTHER THAN THE BLADE TERMINALS
- h. NO PARTING LINES, FLASH, MISMATCHES OR EJECTOR MARKS PERMISSIBLE ON THE INDICATED NOSE SURFACE OR TRANSITION TO INTERNAL SHROUD SURFACE.

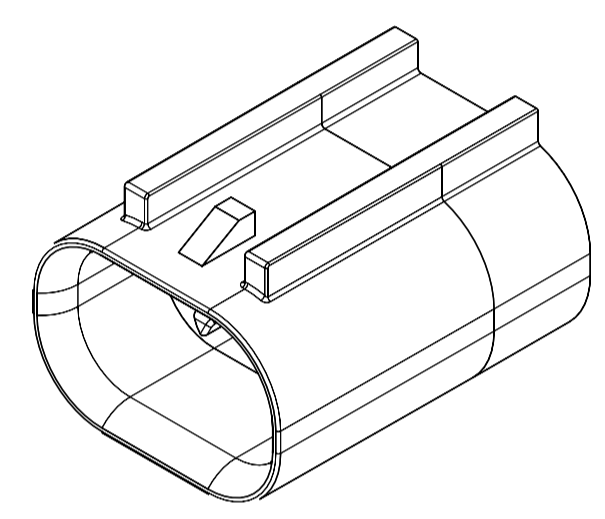

1X4

REV	REV DESCRIPTION
C4	REMOVED ICD-27A. CHANGED ICD-12 AND ICD-28
C3	ADDED SEE NOTE 2b TO PIN DETAILS, SHEET 3
C2	REMOVED SUBJECT TO CHANGE NOTE
C1	REVISED NOTES. SIMPLIFIED DIMENSIONING. REMOVED ICD-17, 19, 29, 31. ADDED ICD-3A, 7A, 8A, 9A, 27A. ADDED FP TO 12, 13, 16.
C	GEOMETRY CHANGES

INSPECTION NUMBER LOG	
LAST NUMBER:	ICD-30
ADDED:	
REMOVED:	ICD-27A

QUALITY SYMBOLS FA = 0 FE = 0 FE = 0 ▽ = 0 C = 0 ☒ = 0 ■ = 0 ▽ = 0	THIS DRAWING CONTAINS INFORMATION THAT IS PROPRIETARY TO MOLEX ELECTRONIC TECHNOLOGIES, LLC AND SHOULD NOT BE USED WITHOUT WRITTEN PERMISSION					
	EC NO: 659036 DRWN: ML1149 CHKD: JCONDON APPR: JCONDON	2021/02/26 2021/03/24 2021/03/24	GENERAL TOLERANCES (UNLESS SPECIFIED) mm ANGULAR TOL ± 3.0 ° 4 PLACES ± 3 PLACES ± 2 PLACES ± 0.1 1 PLACE ± 0.2 0 PLACES ± DRAFT WHERE APPLICABLE MUST REMAIN WITHIN DIMENSIONS	DIMENSION UNITS: mm SCALE: 1:1 DRWN BY: MNS02 DATE: 2016/04/21 CHK'D BY: DATE: APPR BY: KDEKOSKI DATE: 2016/05/04 DRAWING SIZE: A1 THIRD ANGLE PROJECTION		MINI50 SEALED 1X4 INTERFACE PRODUCT CUSTOMER DRAWING
	SERIES: 34968 MATERIAL NUMBER: SEE CHART CUSTOMER:		DIMENSION UNITS: mm SCALE: 1:1			
	DOCUMENT NUMBER: 349684800 DOC TYPE: PSD DOC PART: 000 SHEET NUMBER: 1 OF 4		DIMENSION UNITS: mm SCALE: 1:1			

SHEET DESCRIPTION
KEY CONFIGURATIONS

1X4

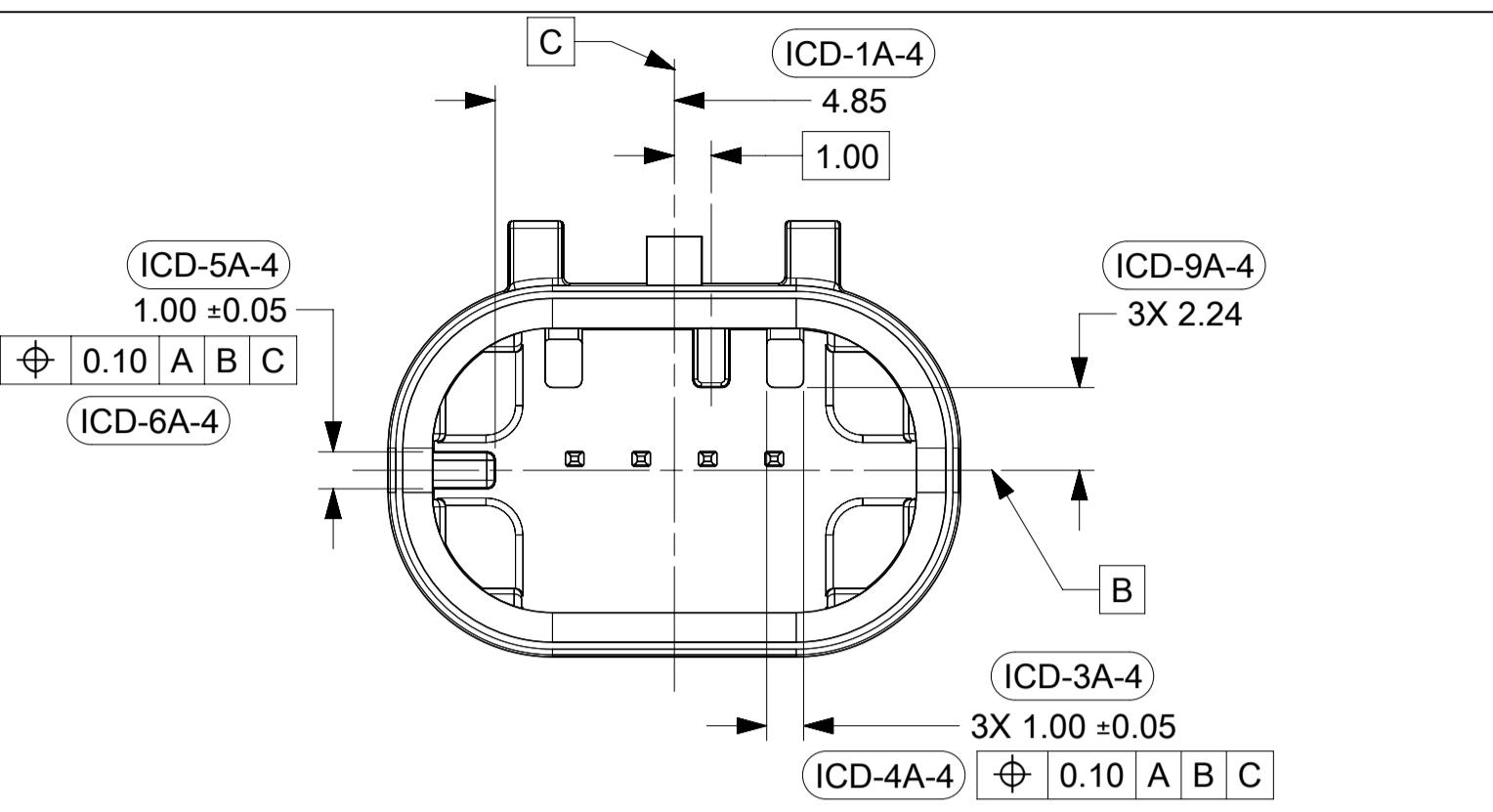

KEY OPTION A

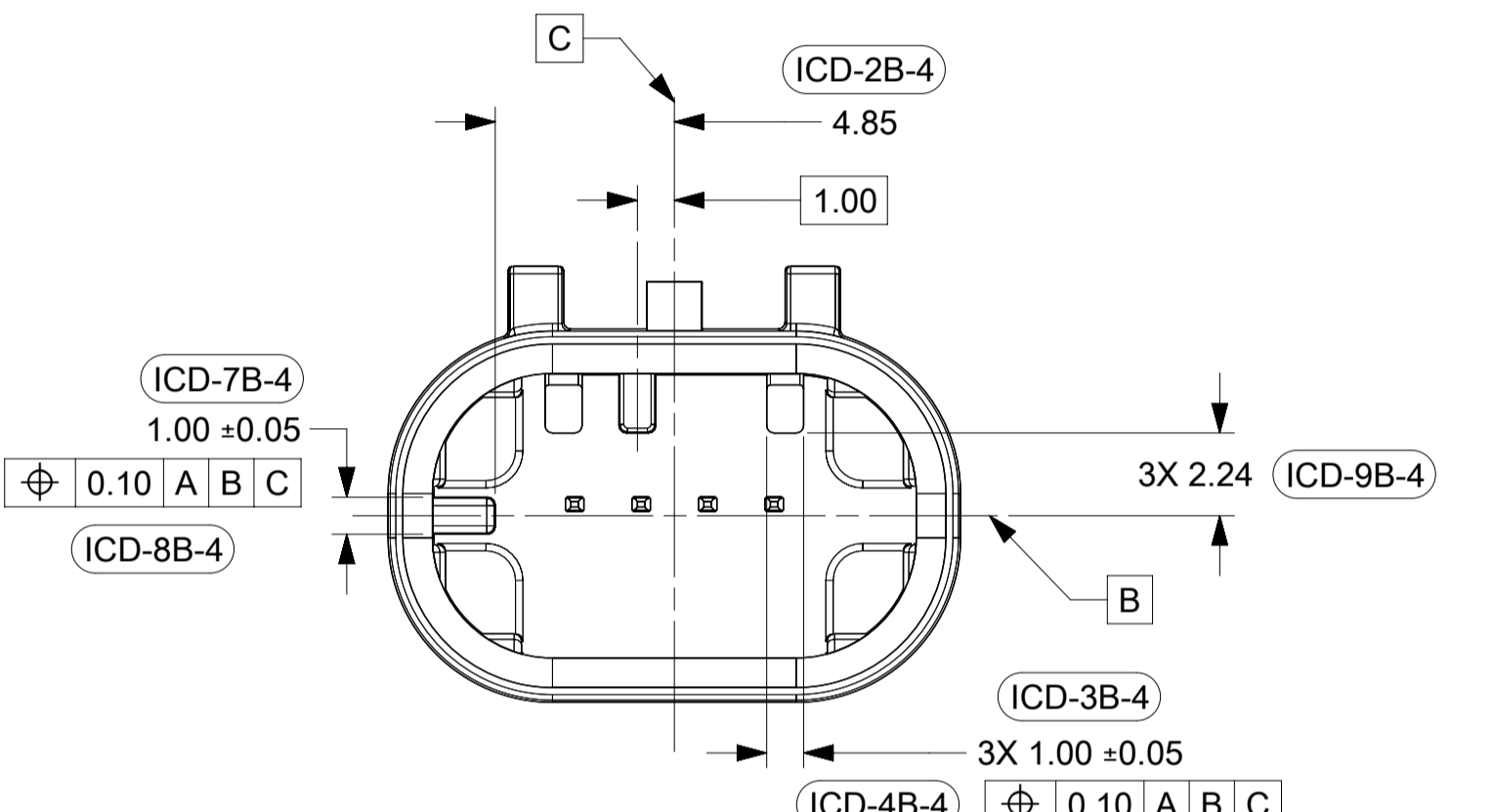

KEY OPTION B

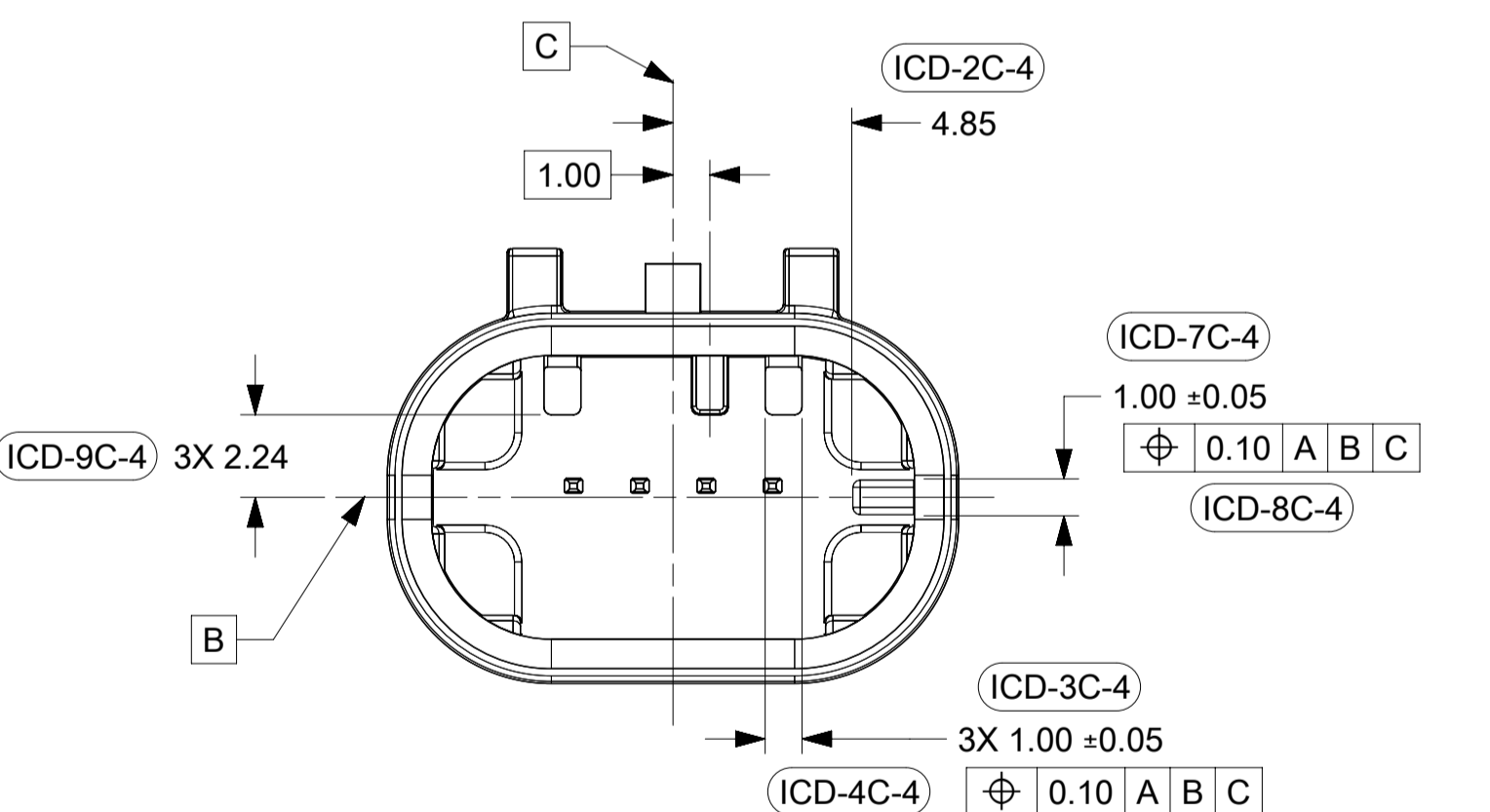

KEY OPTION C

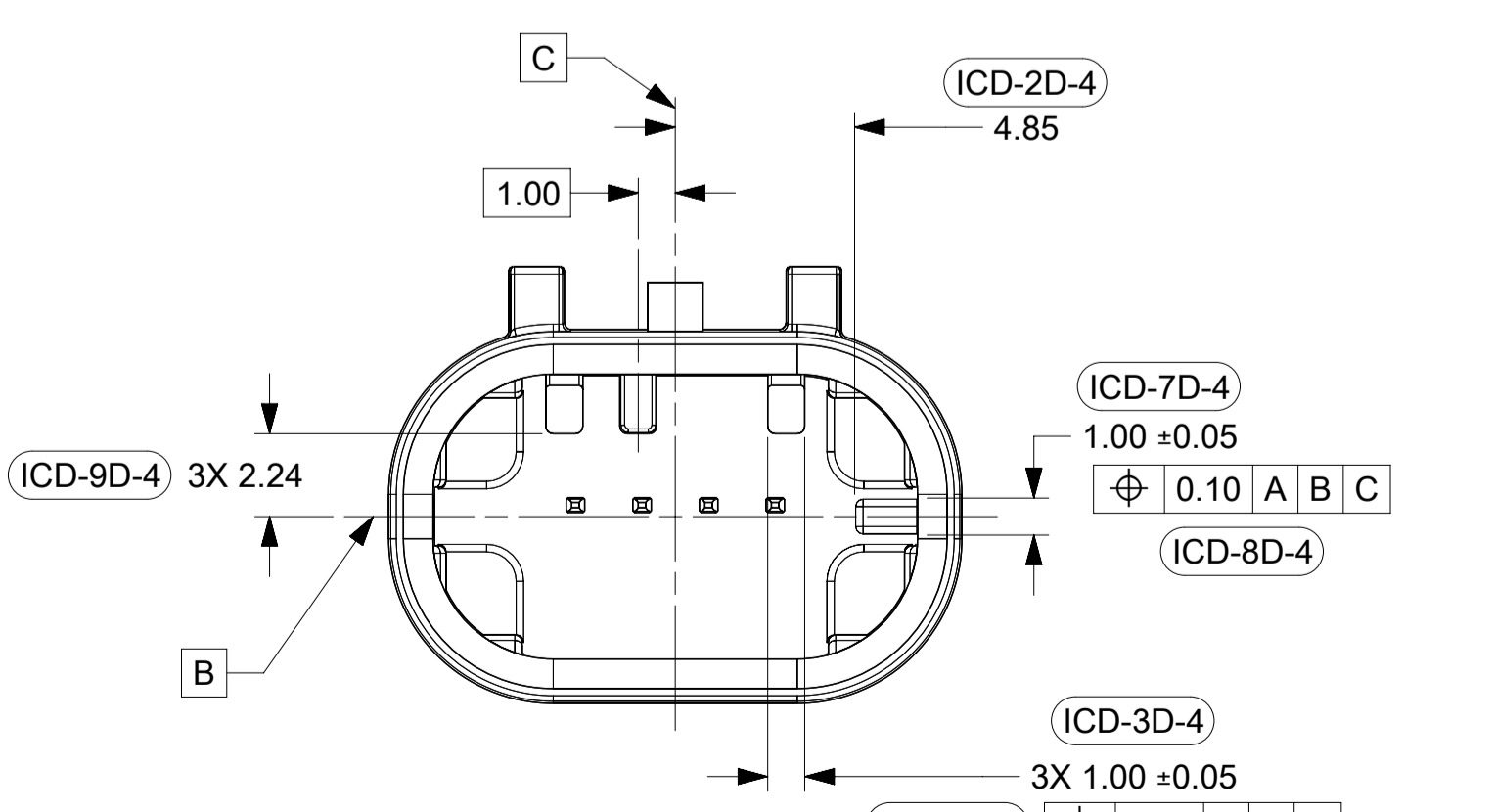

KEY OPTION D

THIS DRAWING CONTAINS INFORMATION THAT IS PROPRIETARY TO MOLEX ELECTRONIC TECHNOLOGIES, LLC AND SHOULD NOT BE USED WITHOUT WRITTEN PERMISSION										
<p>QUALITY SYMBOLS</p> <p>▽ = 0</p> <p>▽ = 0</p> <p>▽ = 0</p> <p>▽ = 0</p> <p>▽ = 0</p> <p>▽ = 0</p> <p>▽ = 0</p> <p>▽ = 0</p> <p>▽ = 0</p> <p>▽ = 0</p>	EC NO:	2021/02/26	GENERAL TOLERANCES (UNLESS SPECIFIED)	DIMENSION UNITS	SCALE					
	DRWN:	ML1149	ANGULAR TOL ± 3.0 °	mm	1:1					
	CHKD:	JCONDON	4 PLACES ±	DRWN BY	DATE					
	APPR:	JCONDON	3 PLACES ±	MNS02	2016/04/21					
	REV:	C4	2 PLACES ± 0.1	CHK'D BY	DATE					
			1 PLACE ± 0.2	KDEKOSKI	2016/05/04					
			0 PLACES ±	APPR BY	DATE					
			DRAFT WHERE APPLICABLE MUST REMAIN WITHIN DIMENSIONS	A1						
				DRAWING SIZE	THIRD ANGLE PROJECTION					
RELEASE STATUS	P1	RELEASE DATE	2021/03/24	15:08:42	<p>SERIES: 34968</p> <p>MATERIAL NUMBER: SEE CHART</p> <p>CUSTOMER:</p>					
DOCUMENT NUMBER			DOC TYPE		DOC PART		SHEET NUMBER			
349684800			PSD		000		2 OF 4			

SHEET DESCRIPTION
DATUM TARGETS

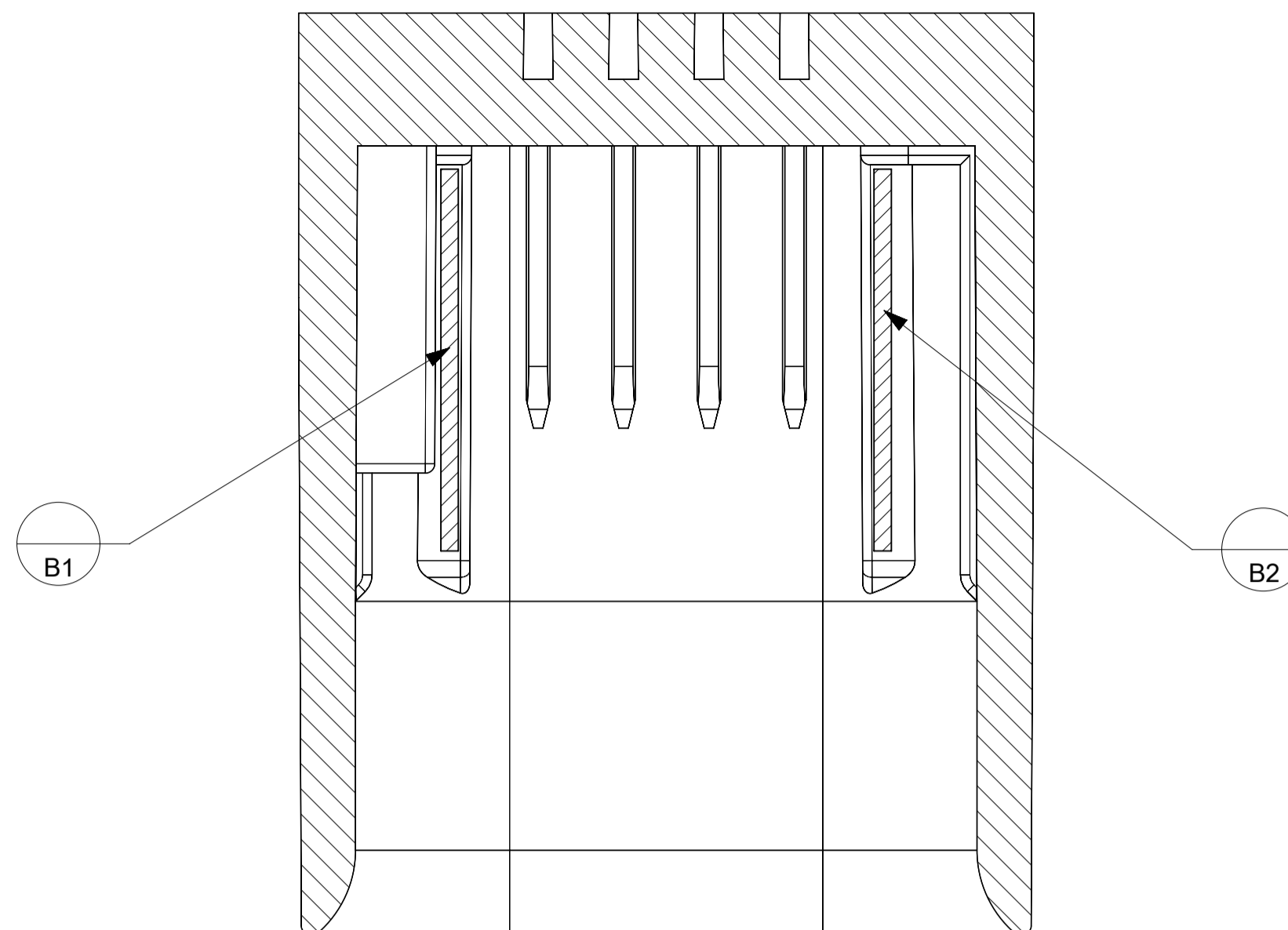

SECTION J-J
SCALE 8:1

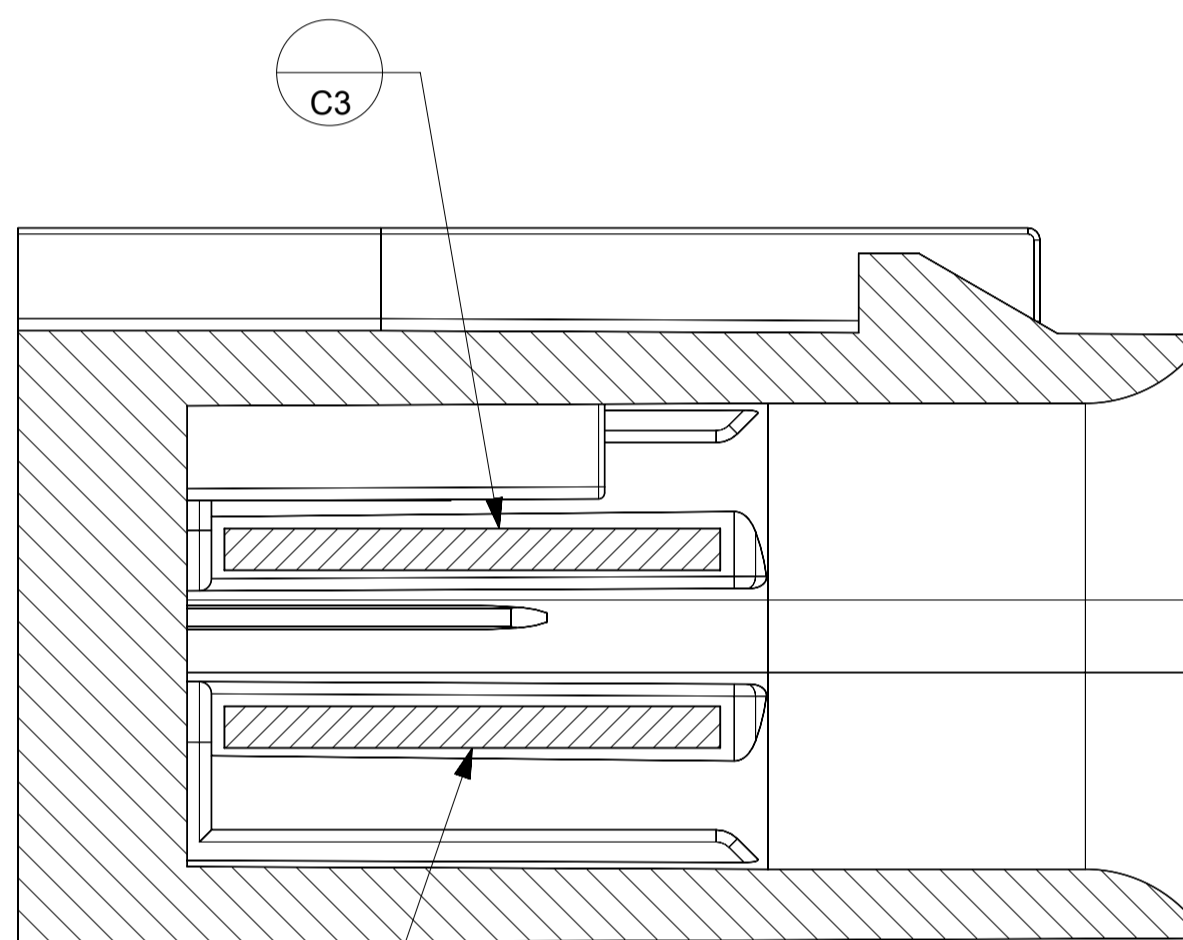

SECTION L-L
SCALE 8:1

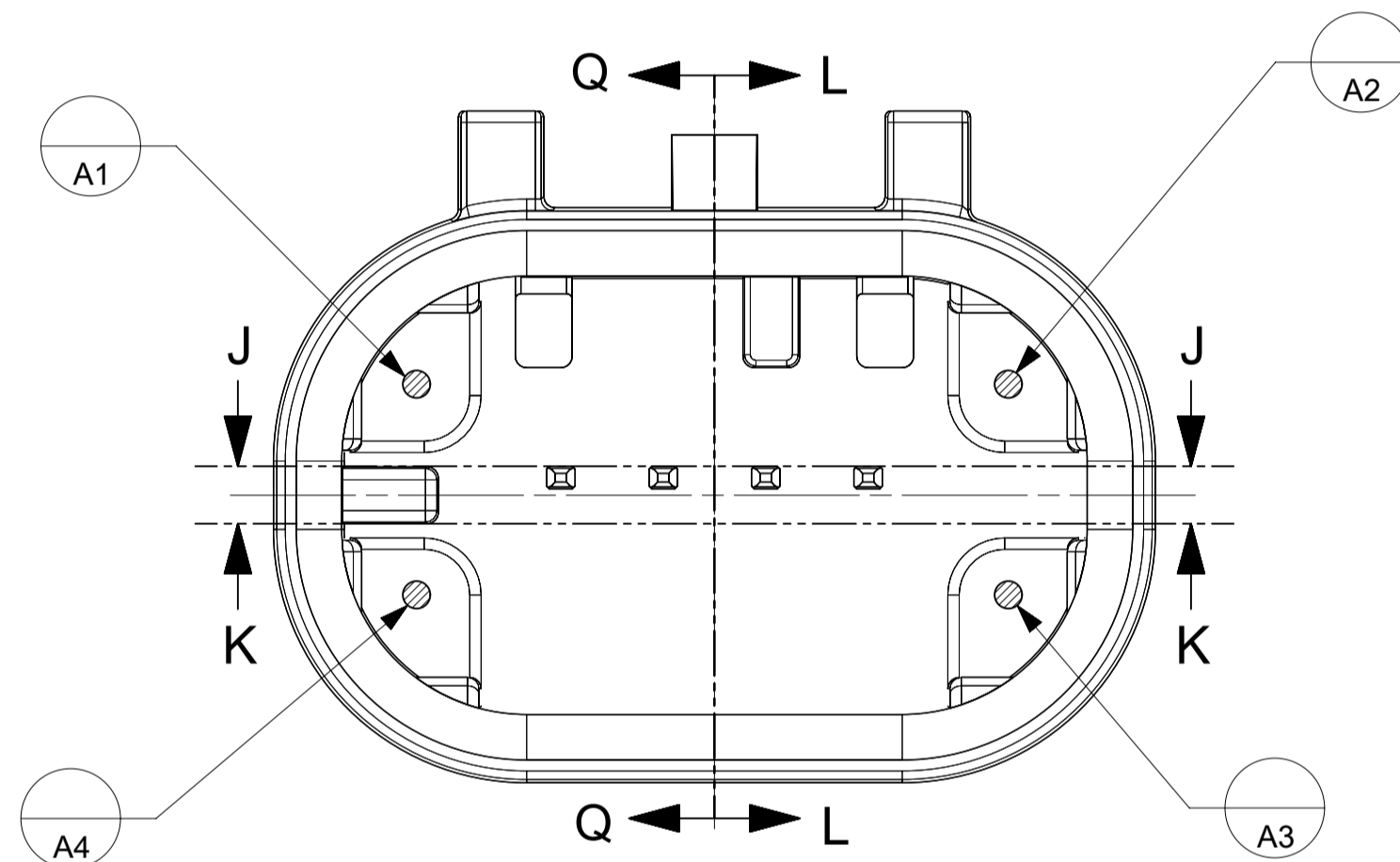

SECTION K-K
SCALE 8:1

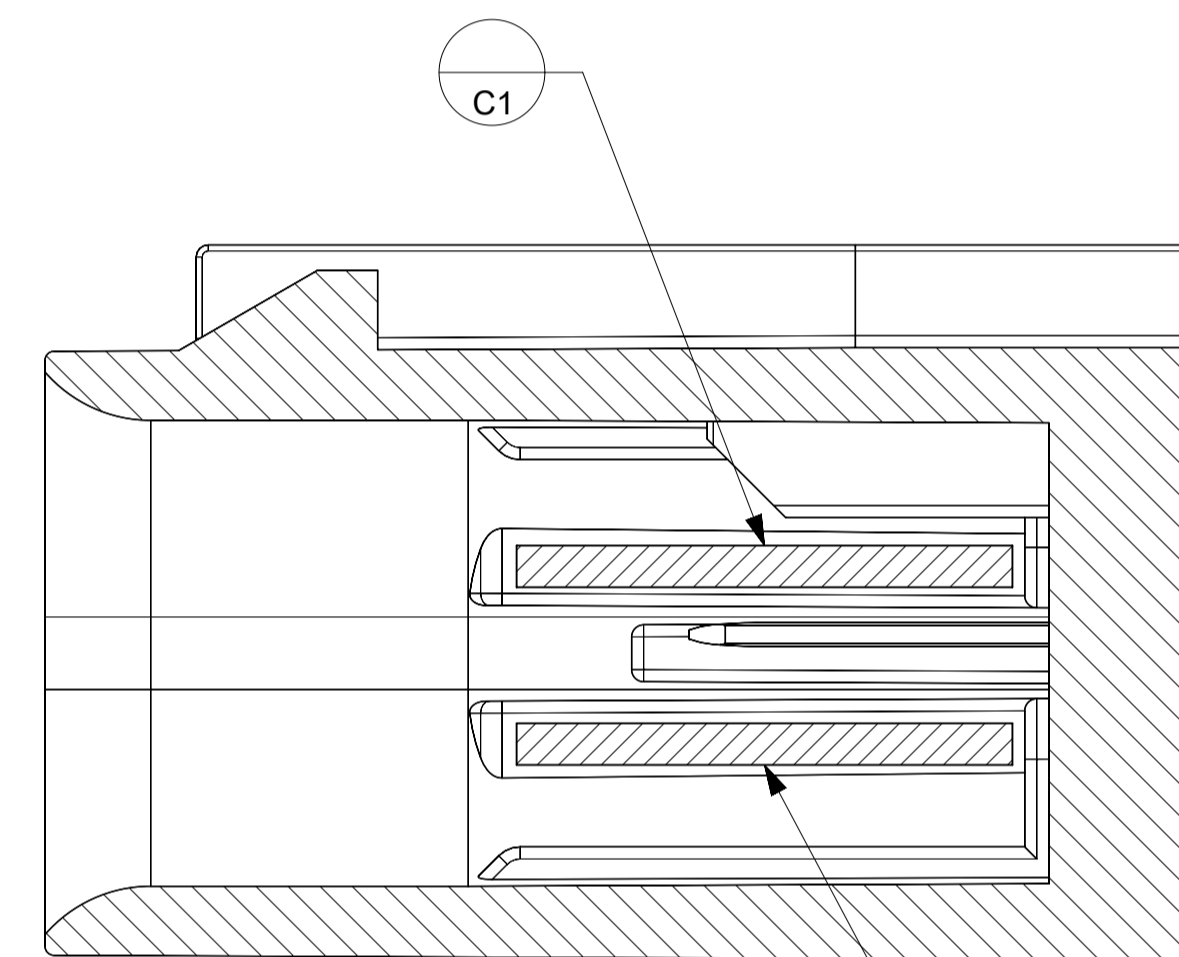

SECTION Q-Q
SCALE 8:1

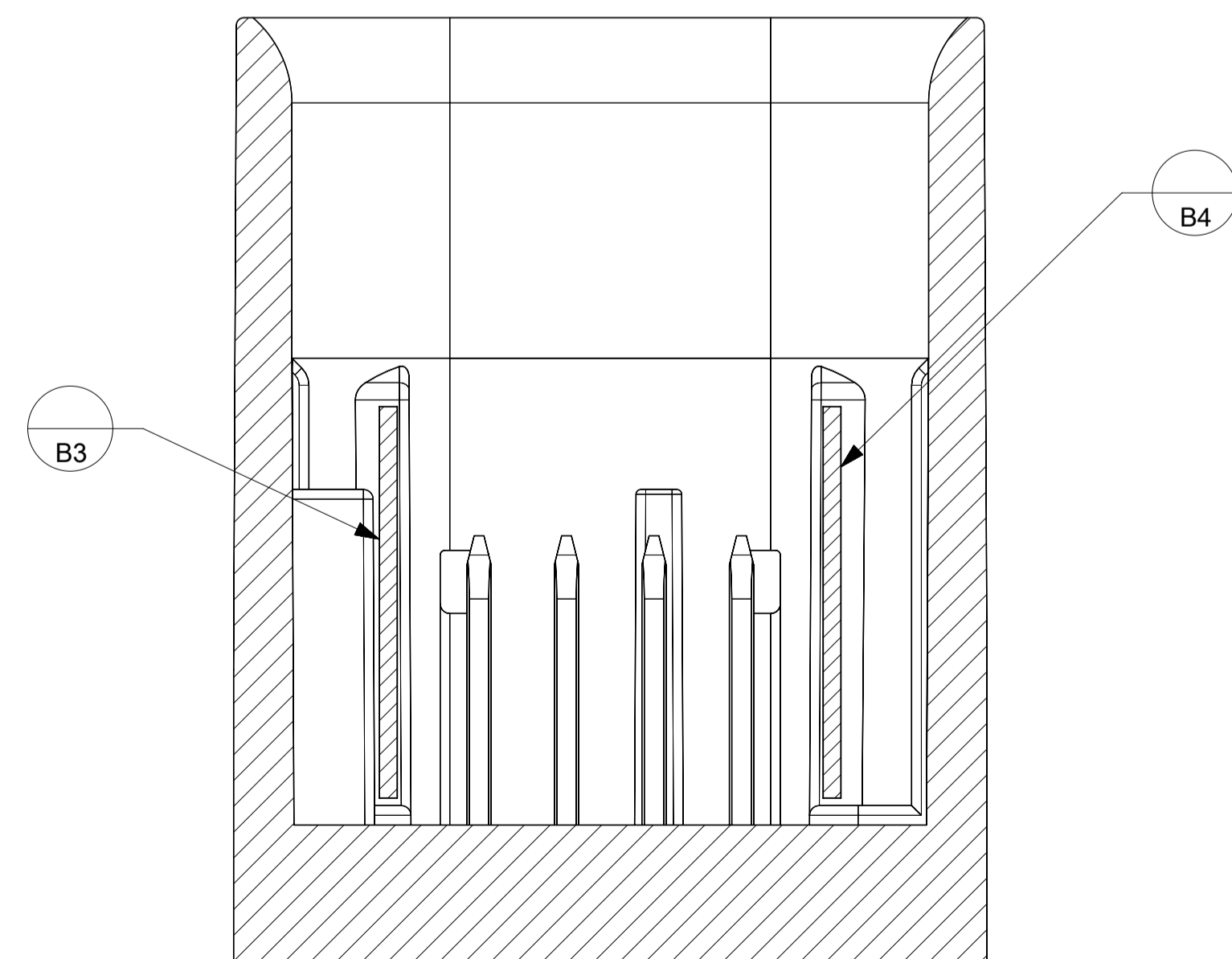

THIS DRAWING CONTAINS INFORMATION THAT IS PROPRIETARY TO MOLEX ELECTRONIC TECHNOLOGIES, LLC AND SHOULD NOT BE USED WITHOUT WRITTEN PERMISSION													
QUALITY SYMBOLS 	EC NO: 659036 DRWN: ML149 CHKD: JCONDON APPR: JCONDON REV: C4	2021/02/26 2021/03/24 2021/03/24	GENERAL TOLERANCES (UNLESS SPECIFIED)		DIMENSION UNITS	SCALE							
			ANGULAR TOL ± 3.0 °		mm	1:1							
			4 PLACES ±	MNS02	2016/04/21								
			3 PLACES ±	CHK'D BY	DATE								
			2 PLACES ± 0.1	APPR BY	DATE	PRODUCT CUSTOMER DRAWING							
			1 PLACE ± 0.2	KDEKOSKI	2016/05/04	SERIES	MATERIAL NUMBER	CUSTOMER					
			0 PLACES ±	DRAWING SIZE		THIRD ANGLE PROJECTION	34968	SEE CHART					
			DRAFT WHERE APPLICABLE MUST REMAIN WITHIN DIMENSIONS		A1		DOCUMENT NUMBER	DOC TYPE	DOC PART	SHEET NUMBER			
							349684800	PSD	000	4 OF 4			