

**SPECIFICATIONS:**

**MATERIALS:**

SHELL: NICKEL PLATED STEEL  
 INSULATOR: PA6T, UL94 V-0  
 PROCESS TEMP: 260°C  
 CONTACTS: GOLD PLATED BRASS (FLOATING CONTACTS)

**ELECTRICAL:**

RATED CURRENT: 5A  
 VOLTAGE: 500VAC FOR 1 MINUTE  
 INSULATION RESISTANCE: 1000 MOhms MIN.  
 CONTACT RESISTANCE: 15 mOhms MAX.

**ENVIRONMENT:**

OPERATING TEMPERATURE: -50°C TO +100°C

DIMENSIONS(mm)							
SIZE	A <sup>±.36</sup>	B <sup>±.10</sup>	C <sup>±.15</sup>	D <sup>±.15</sup>	E <sup>±.38</sup>	F <sup>±.25</sup>	G (REF)
9	30.80	24.99	16.30	8.00	19.20	12.60	10.75
15	39.15	33.32	24.60	8.00	27.70	12.60	10.75
25	53.04	47.04	38.40	8.00	41.10	12.60	10.75
37	69.32	63.50	54.80	8.00	57.30	12.60	10.75
50	66.93	61.11	52.30	10.80	55.10	15.20	13.30

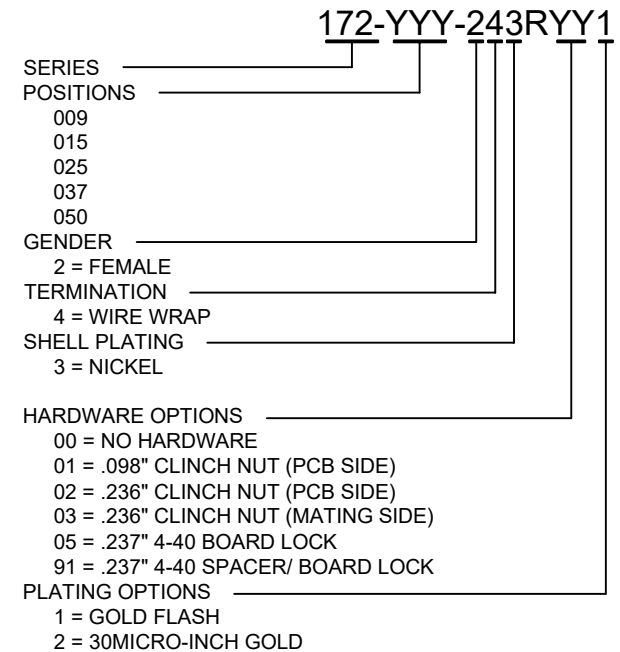
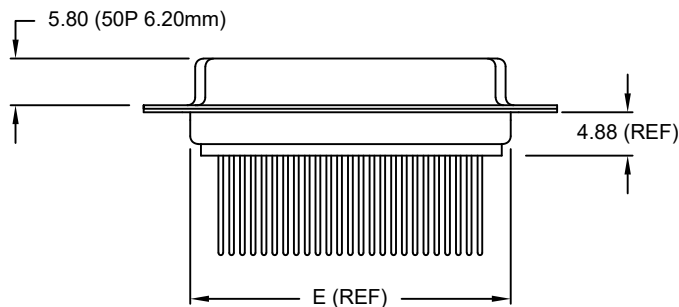
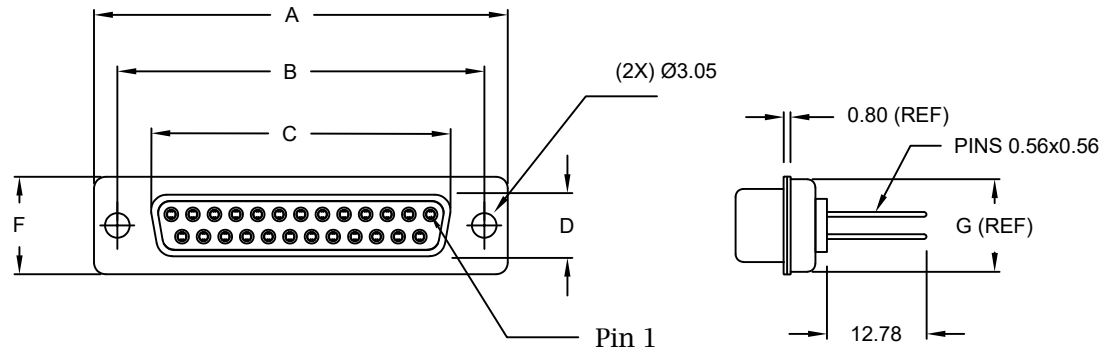

RoHS COMPLIANT

UNITS = mm

DO NOT SCALE FROM DRAWING



THESE DRAWINGS AND SPECIFICATIONS ARE THE PROPERTY OF NorComp AND SHALL NOT BE REPRODUCED, COPIED OR USED AS THE BASIS FOR THE MANUFACTURE OR SALE OF APPARATUS WITHOUT WRITTEN PERMISSION.

DRAWN:  
P. JENKINS

DATE:  
09/12/2005

NorComp

SCALE:  
NTS

SHEET OF  
1 3

REV  
16

DWG NO.

172-YYY-243RYY1

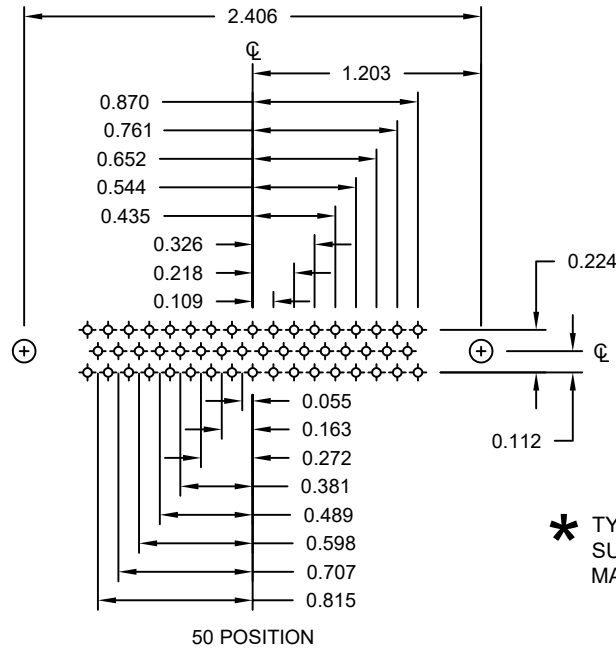
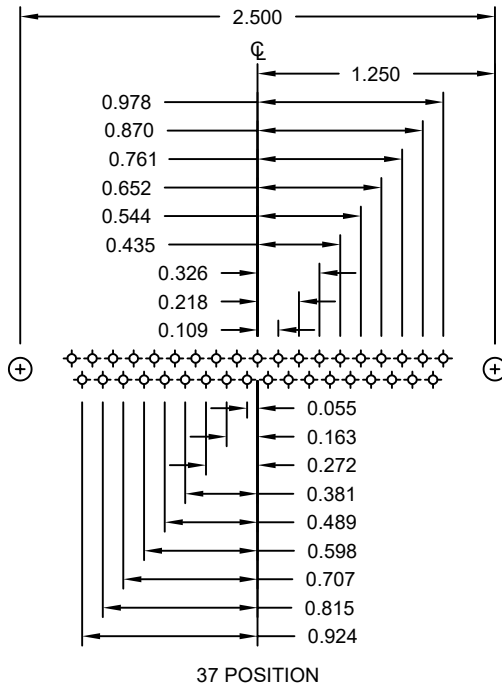
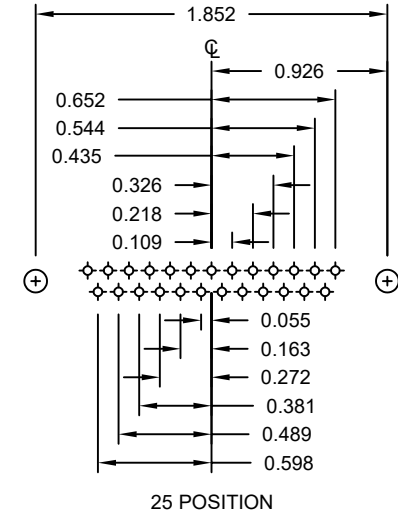
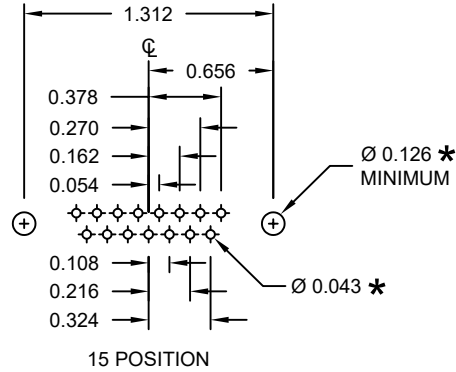
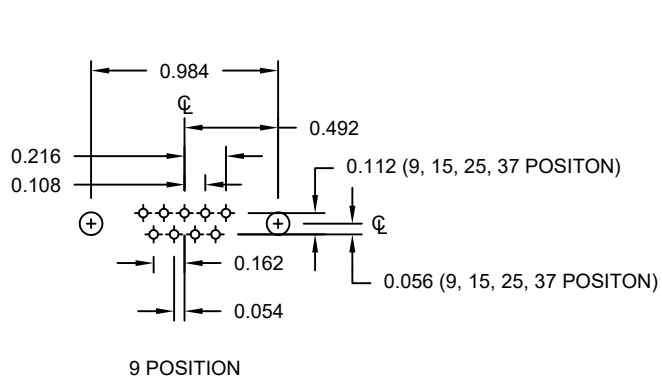

\* TYP.  
SUGGESTED SIZE  
MAY NOT BE SUITABLE FOR ALL APPLICATIONS

RoHS COMPLIANT

UNITS = inch

DO NOT SCALE FROM DRAWING



THESE DRAWINGS AND SPECIFICATIONS ARE THE PROPERTY OF NorComp AND SHALL NOT BE REPRODUCED, COPIED OR USED AS THE BASIS FOR THE MANUFACTURE OR SALE OF APPARATUS WITHOUT WRITTEN PERMISSION.

DRAWN:  
P. JENKINS

DATE:  
09/12/2005

NorComp

SCALE:  
NTS

SHEET OF  
2 3

REV  
16

DWG NO.

172-YYY-243RYY1

ALL CLINCH-NUTS ARE 4-40 INTERNAL THREADS

01X ..... 0.098" (PCB SIDE)

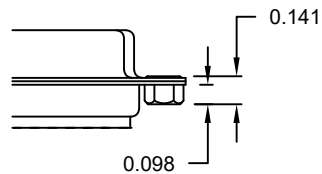

02X ..... 0.236" (PCB SIDE)

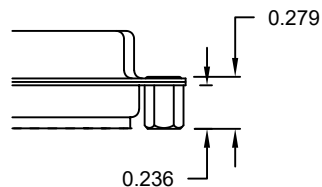

03X..... 0.236" (MATING SIDE)

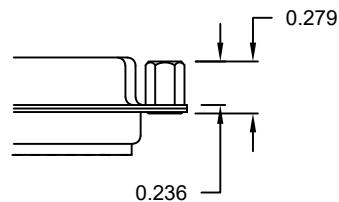

05X ..... 0.237" (BOARD SIDE)

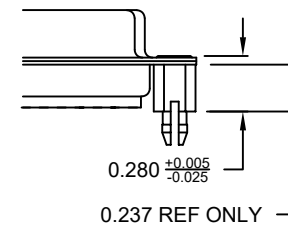

91X ..... 0.237" (BOARD SIDE)

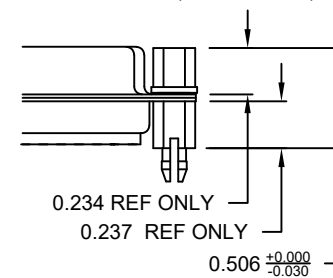

**TOLERANCE:**  
ALL DIMENSIONS ARE  $\pm 0.010$   
UNLESS OTHERWISE  
SPECIFIED

NOTE: 4-40 FEMALE SCREW LOCK IS REMOVABLE

50 in-oz  
Max Torque

RoHS COMPLIANT

UNITS = inch

DO NOT SCALE FROM DRAWING



THESE DRAWINGS AND SPECIFICATIONS ARE THE PROPERTY OF NorComp AND SHALL NOT BE REPRODUCED, COPIED OR USED AS THE BASIS FOR THE MANUFACTURE OR SALE OF APPARATUS WITHOUT WRITTEN PERMISSION.

DRAWN:  
P. JENKINS

DATE:  
09/12/2005

NorComp

SCALE:  
NTS

SHEET 3 OF 3

REV 16

DWG NO.

172-YYY-243RYY1