

LOC		DIST		REVISIONS			
CM	00	P	LTN	DESCRIPTION	DATE	DWN	APVD
		C1		REVISED PER ECR-18-004355	18JUN2018	BDA	SG
		C2		REVISED PER ECR-20-003408	11MAR2020	BKW	SW

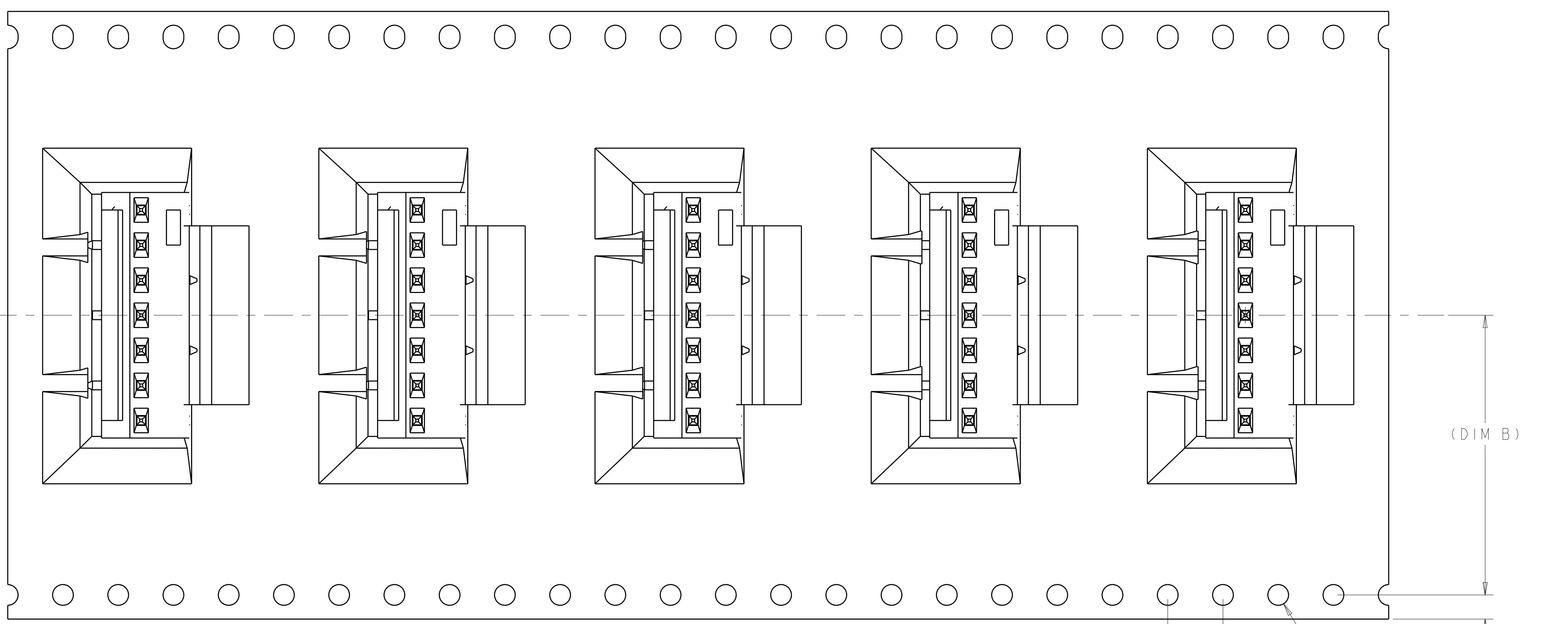

- △ MATERIAL:
 HEADER- NYLON 4/6, HIGH TEMPERATURE, UL94V-0
 POST: COPPER ALLOY
 CAVITY CARRIER TAPE: BLACK CONDUCTIVE POLYCARBONATE
 COVER TAPE: POLYESTER FILM TAPE.
- △ FINISH:
 HOUSING: COLOR, BLACK
 POST: 0.00381 [.000015] GOLD OVER NICKEL.
- △ POSTS TO WITHSTAND 13 NEWTONS [3 LBS] MIN AXIAL FORCE IN THIS DIRECTION WITHOUT DISLODGING, BEFORE SOLDERING.
- △ POSTS SOLDER TAILS MUST COMPLY WITH AMP SOLDERABILITY SPEC 109-11-2.
- △ MEASURED AT [-A-].
- △ APPLIES WHEN HEADER IS HELD STRAIGHT.
- △ COORDINATE DIMENSION APPLIES FROM CENTER OF ACTUAL FEATURE.
- △ DIMENSIONS APPLY TO THE COMPONENT SIDE OF BOARD.
- △ MAXIMUM TEMPERATURE EXPOSURE DURING REFLOW SOLDERING NOT TO EXCEED 280°C [536°F].
- 10. HEADERS ARE SUPPLIED ON A 330.2mm [13 INCH] DIAMETER REEL, WITH 225 PARTS PER REEL. THE CAVITY CARRIER TAPE HOLDS 1 PART PER POCKET, ORIENTED AS SHOWN.
- △ AMP LOGO, UL AND CSA TRADEMARKS TO APPEAR ON THIS SURFACE.
- △ MATTE TIN 0.00381 [.000150] MIN THICK ON SOLDER TAIL.

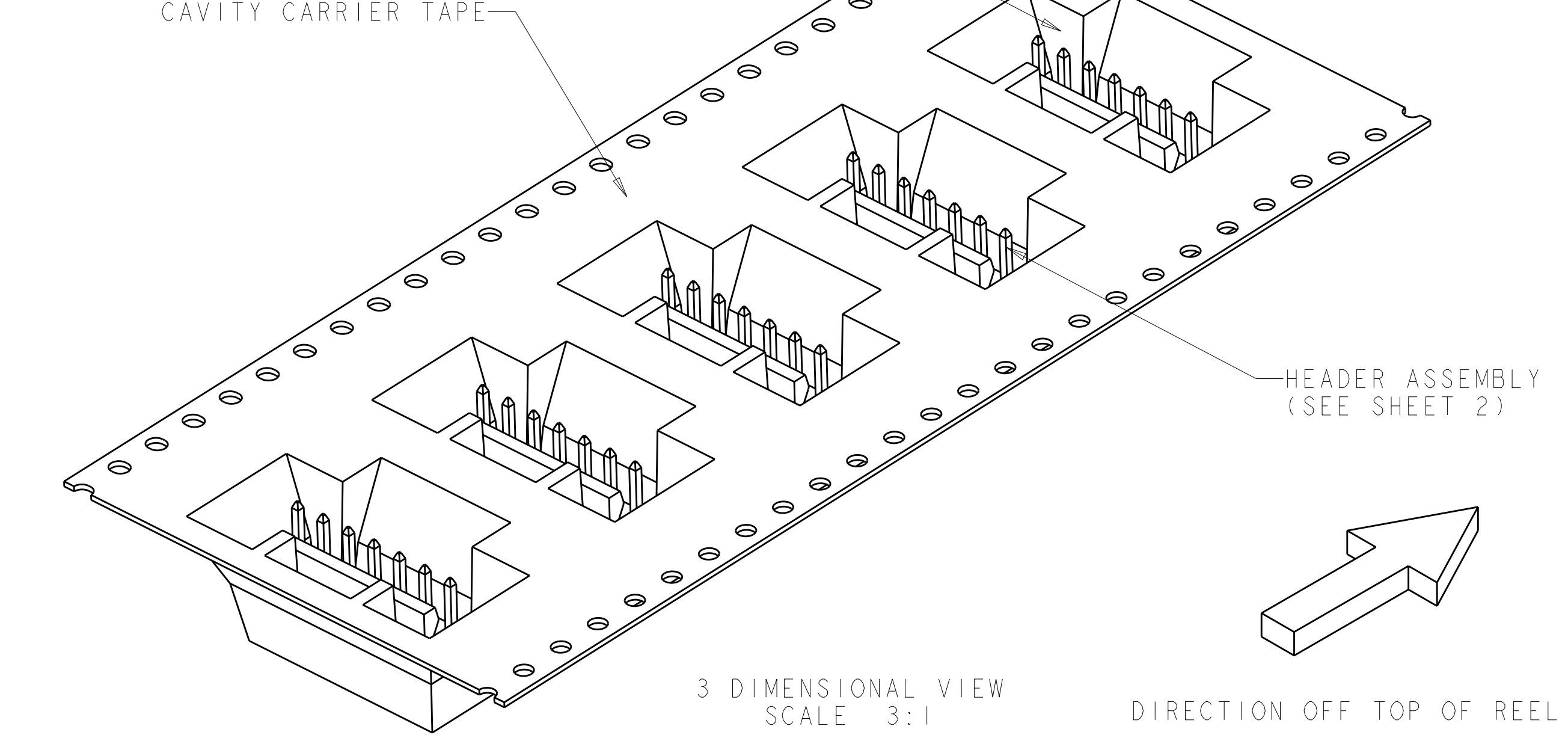
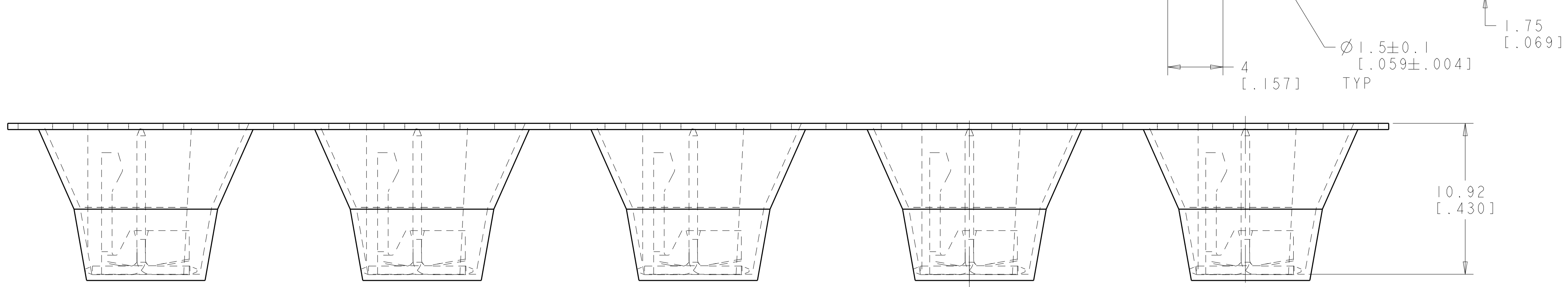

3-647467-7 SHOWN

SEE SHEET 2 FOR PART NUMBER TABLE

THIS DRAWING IS A CONTROLLED DOCUMENT.		DWN: R. WHITAKER 09JAN2007	TE Connectivity
DIMENSIONS: mm [INCHES]		CHK: D. BOSSI 09JAN2007	
TOLERANCES UNLESS OTHERWISE SPECIFIED:		APVD: D. BOSSI 09JAN2007	NAME: MTA-100 HDR ASSY, SURFACE MOUNT, FRICTION LOCK, .025 SQUARE POST, 15 GOLD PLATED, CARRIER TAPE LOADER
0 PLC ±	1 PLC ±	PRODUCT SPEC	SIZE: CAGE CODE DRAWING NO. RESTRICTED TO
2 PLC ±	3 PLC ±	APPLICATION SPEC	A100779C=647467
4 PLC ±	ANGLES ±	WEIGHT	SCALE 5:1 SHEET 1 OF 2 REV C2
MATERIAL: △	FINISH: △	CUSTOMER DRAWING	

LOC	DIST	REVISIONS			
		REV	DATE	BY	APPV
CM	00	-	SEE SHEET 1	-	-

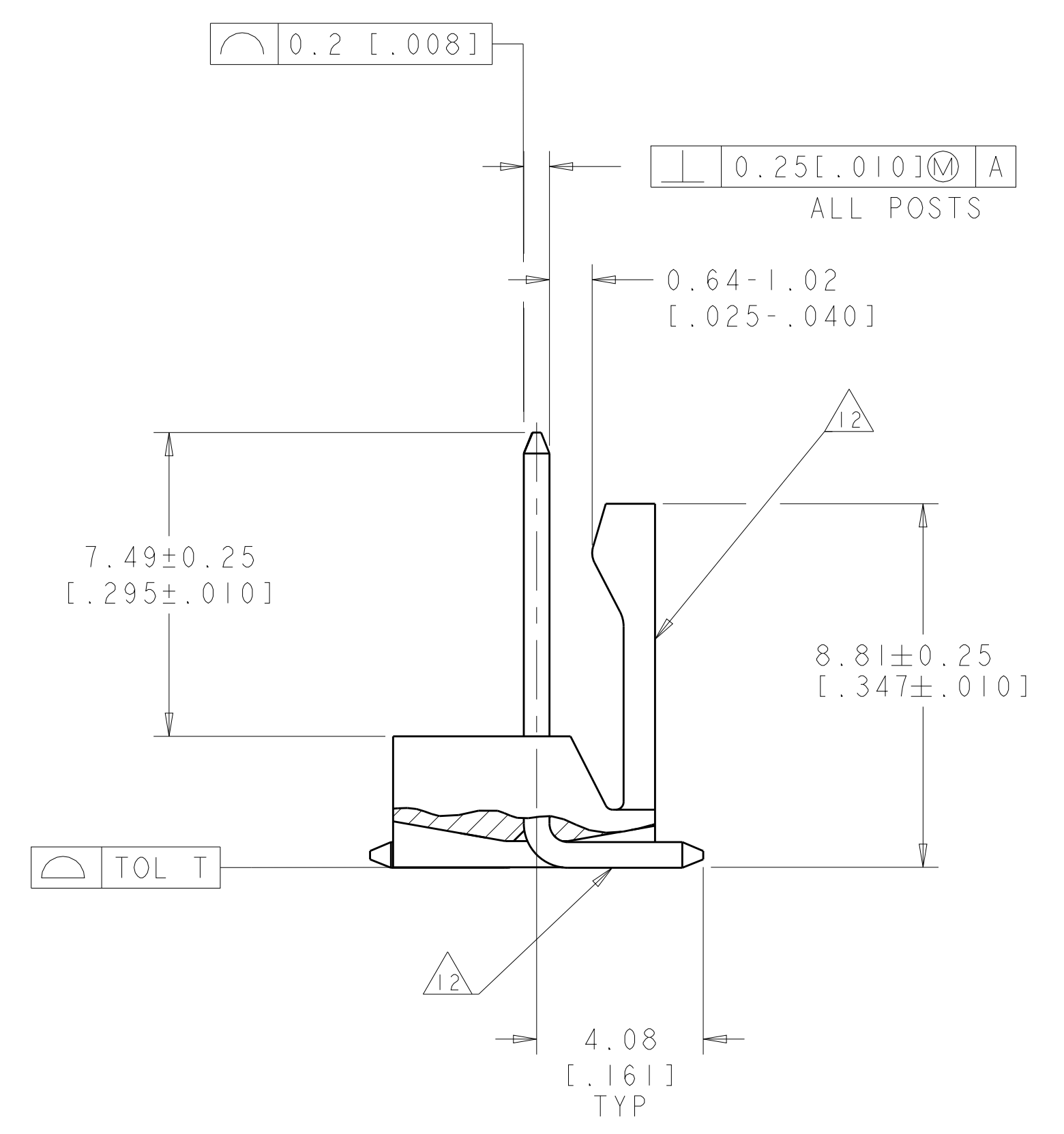
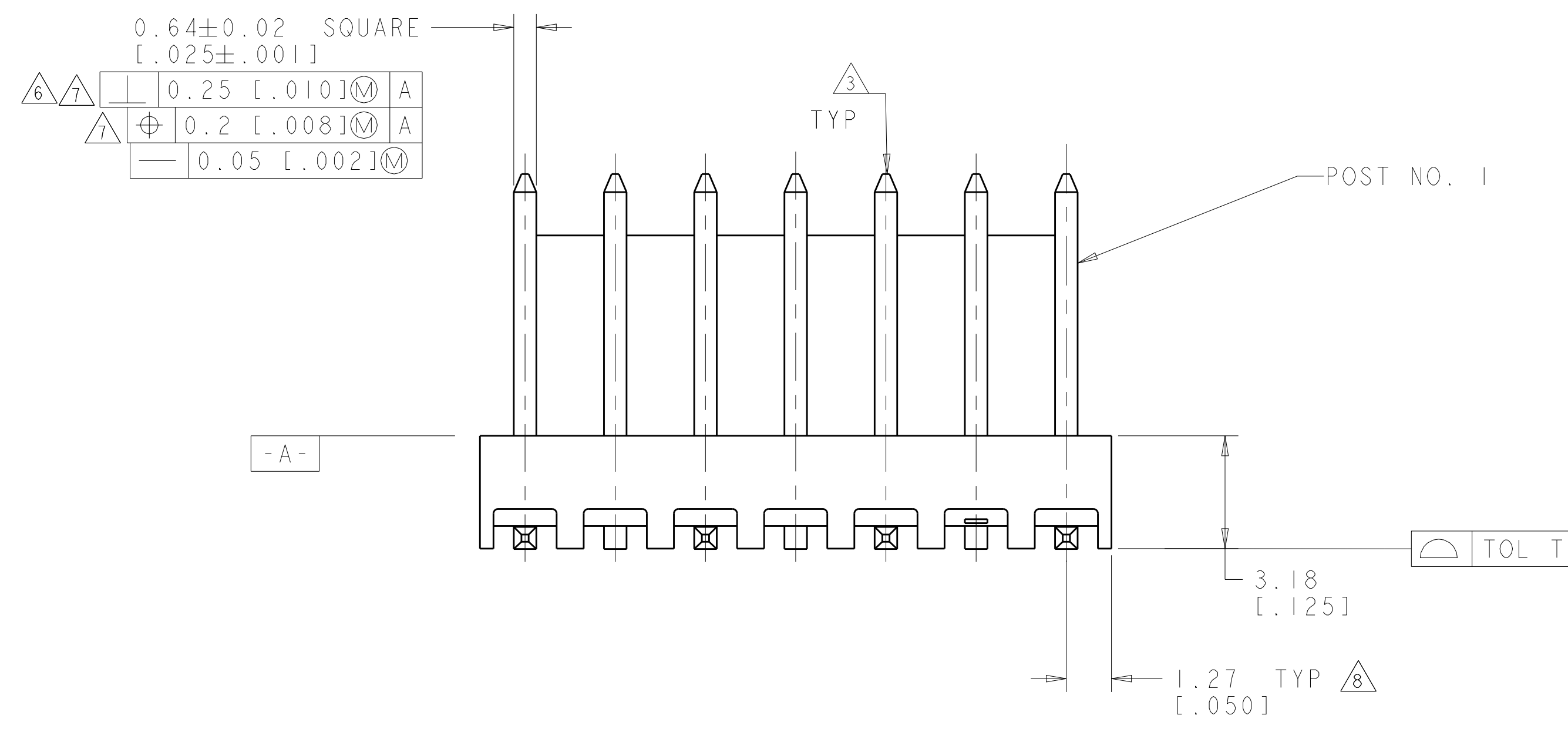
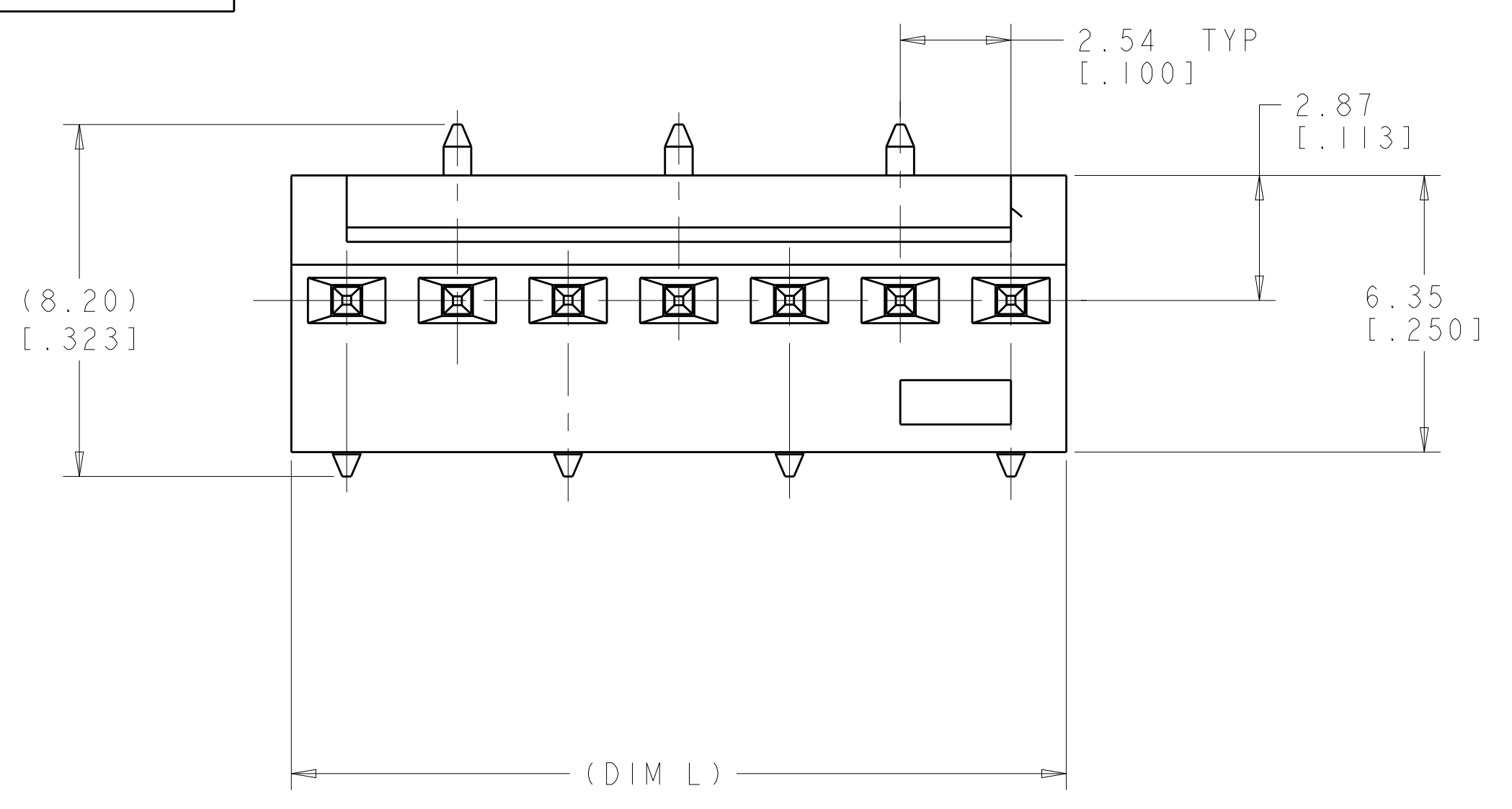

HEADER ASSEMBLY
SCALE 8:1

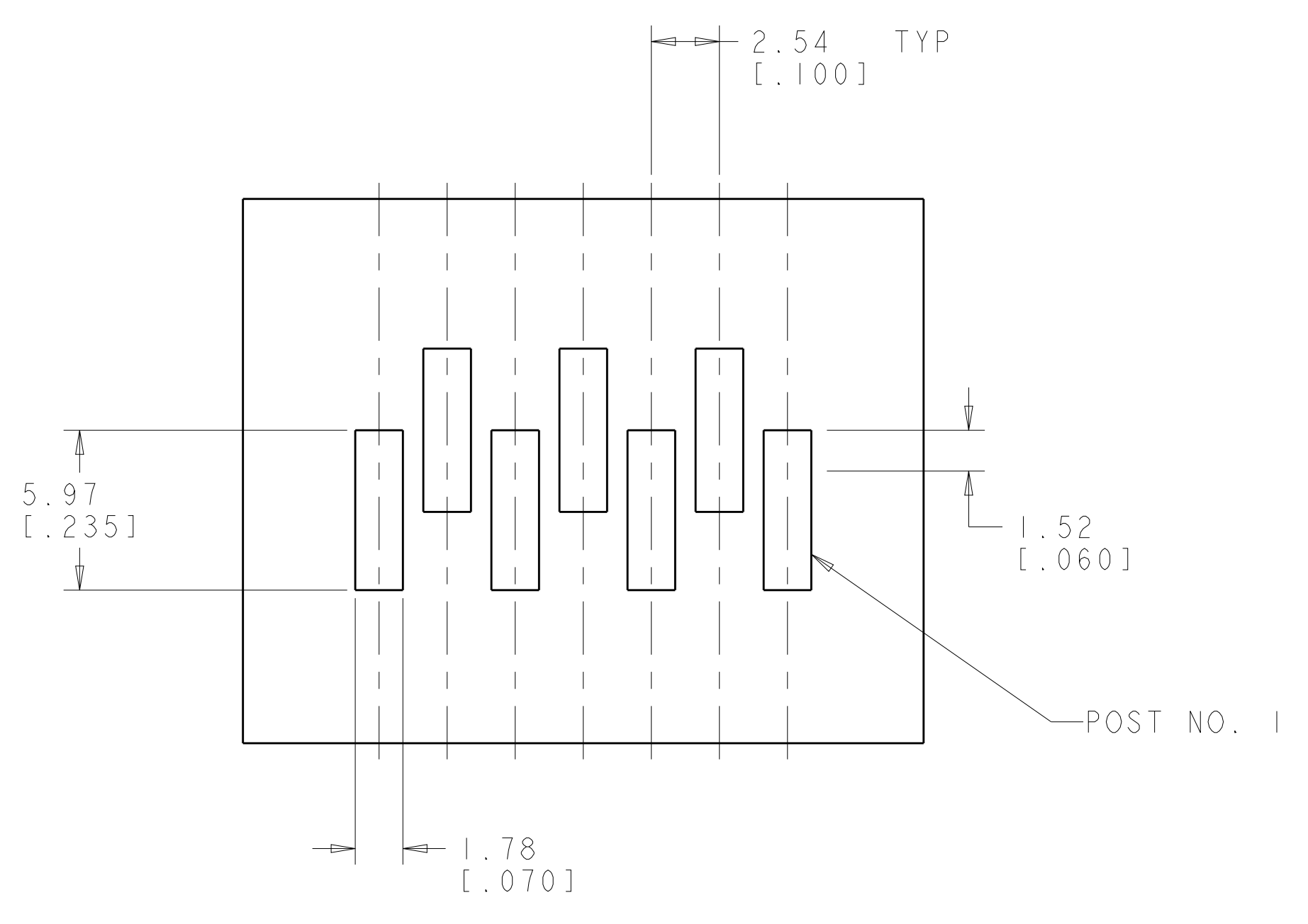

RECOMMENDED P.C. BOARD LAYOUT
FOR USE WITH 0.25 [.010] THICK STENCIL
SCALE 5:1

PRELIMINARY	0.2 [.008]	34.25 [1.348]	72.00 [2.835]	45.72 [1.800]	18	4-647467-8
PRELIMINARY	0.2 [.008]	34.25 [1.348]	72.00 [2.835]	43.18 [1.700]	17	4-647467-7
PRELIMINARY	0.2 [.008]	34.25 [1.348]	72.00 [2.835]	40.64 [1.600]	16	4-647467-6
PRELIMINARY	0.2 [.008]	34.25 [1.348]	72.00 [2.835]	38.10 [1.500]	15	4-647467-5
PRELIMINARY	0.2 [.008]	26.20 [1.031]	56.00 [2.205]	35.56 [1.400]	14	4-647467-4
PRELIMINARY	0.2 [.008]	26.20 [1.031]	56.00 [2.205]	33.02 [1.300]	13	4-647467-3
PRELIMINARY	0.15 [.006]	26.20 [1.031]	56.00 [2.205]	30.48 [1.200]	12	4-647467-2
PRELIMINARY	0.15 [.006]	26.20 [1.031]	56.00 [2.205]	27.94 [1.100]	11	4-647467-1
PRELIMINARY	0.15 [.006]	20.20 [.795]	44.00 [1.732]	25.40 [1.000]	10	4-647467-0
PRELIMINARY	0.15 [.006]	20.20 [.795]	44.00 [1.732]	22.86 [.900]	9	3-647467-9
PRELIMINARY	0.15 [.006]	20.20 [.795]	44.00 [1.732]	20.32 [.800]	8	3-647467-8
PRELIMINARY	0.15 [.006]	20.20 [.795]	44.00 [1.732]	17.78 [.700]	7	3-647467-7
PRELIMINARY	0.15 [.006]	14.20 [.559]	32.00 [1.260]	15.24 [.600]	6	3-647467-6
PRELIMINARY	0.15 [.006]	14.20 [.559]	32.00 [1.260]	12.70 [.500]	5	3-647467-5
PRELIMINARY	0.15 [.006]	14.20 [.559]	32.00 [1.260]	10.16 [.400]	4	3-647467-4
PRELIMINARY	0.15 [.006]	14.20 [.559]	32.00 [1.260]	7.62 [.300]	3	3-647467-3
PRELIMINARY	0.15 [.006]	11.50 [.453]	24.00 [.945]	5.08 [.200]	2	3-647467-2
	TOL T	DIM B	DIM A	DIM L	NO. OF POSN	PART NUMBER

THIS DRAWING IS A CONTROLLED DOCUMENT. OWN: H. WHITAKER 09JAN2007
CHK: D. BOSSI 09JAN2007
APVD: D. BOSSI 09JAN2007

DIMENSIONS: mm [INCHES] TOLERANCES UNLESS OTHERWISE SPECIFIED:
0 PLC ±
1 PLC ±
2 PLC ±
3 PLC ±0.38 [.015]
4 PLC ±
ANGLES 40° 30'

MATERIAL: FINISH: WEIGHT: CUSTOMER DRAWING

NAME: MTA-100 HDR ASSY, SURFACE MOUNT, FRICTION LOCK, .025 SQUARE POST, 15 GOLD PLATED, CARRIER TAPE LOADED
SIZE: CAGE CODE: DRAWING NO: A100779 C=647467
SCALE: 5:1 SHEET 2 OF 2 REV C2

STE TE Connectivity