



# HARWIN

## Component Specification

**C01711**

M80-7XX Series Connectors – Three Row (Legacy)  
November 2022

SECTION	TITLE	PAGE
1	Description of Connector and Intended Application	2
2	Ratings	2
Appendix 1	Contact Orientations	3
Appendix 2	Instructions for the use of connectors fitted with Jackscrews	5
Appendix 3	Gauges	5

## 1. DESCRIPTION OF CONNECTOR AND INTENDED APPLICATION

A range of 2mm pitch male and female rectangular, fully shrouded unsealed connectors with replaceable contacts for interconnecting board to board and board to wire. The range covers female connectors suitable for crimp or through board termination and male connectors available for straight or 90° through-board termination. The connectors are provided with a range of contact terminations which are gold or gold/tin plated. The contact zone of the contacts are plated with hard acid gold of 98% purity.

The connector is intended for use as a connector in high packing density electronic equipment. The connector is polarised to prevent mis-matching and can be produced with a jackscrew feature as required.

## 2. RATINGS

### 2.1. Current Rating

Standard Contacts:

One contact per connector is electrically loaded, 25°C ambient .....	3.3A max
One contact per connector is electrically loaded, 85°C ambient .....	2.6A max
Current per contact through all contacts, 25°C ambient .....	3.0A max
Current per contact through all contacts, 85°C ambient .....	2.2A max

Power Contacts:

One contact per connector is electrically loaded, 25°C ambient .....	16.5A max
One contact per connector is electrically loaded, 85°C ambient .....	13.0A max
Current per contact through all contacts, 25°C ambient .....	15.0A max
Current per contact through all contacts, 85°C ambient .....	11.0A max

### 2.2. Other Electrical Characteristics

Working Voltage (at sea level) .....	120V DC or AC peak
Voltage Proof .....	360V DC or AC peak
Contact Resistance:	
Initial .....	20mΩ max
After Conditioning .....	25mΩ max
Insulation resistance:	
Initial .....	1,000MΩ min
Hot After Conditioning .....	100MΩ min
Creepage Path contact-to-contact .....	0.35mm min
Air Gap contact-to-contact .....	0.35mm min

### 2.3. Environmental Characteristics

Environmental Classification .....	55/125/56
Operating Temperature Range .....	-55°C to +125°C
Low Air Pressure Severity .....	300 mbar
Vibration severity .....	10Hz to 2,000Hz, 0.75mm, 98m/s <sup>2</sup> (10G), duration 6 hours
Bump Severity .....	390m/s <sup>2</sup> (40G), 4,000±10 bumps
Shock Severity .....	981m/s <sup>2</sup> (100G) for 6ns
Acceleration Severity .....	490m/s <sup>2</sup> (50G)

### 2.4. Mechanical Characteristics

Durability .....	500 operations
High Temperature, Long Term (current as in 2.1.1.) .....	1,000 hours at 85°C
High Temperature, Short Term (no electrical load) .....	250 hours at 125°C
Contact Retention in Housing .....	10N min
Cable Contact Retention in Housing (after 3 replacements) .....	10N min
Contact Holding Force (after 3 sizings using holding gauge shown in A3.3.) .....	0.2N min

Insertion and Withdrawal Forces (complete mated connectors without jackscrew fitted):

Total No. of Contacts	Insertion (max)	Withdrawal (max)	Withdrawal (min)
27 signal	76N	49N	5.4N
36 signal	101N	65N	7N
45 signal	126N	81N	9N
51 signal	143N	92N	10N
63 signal	177N	144N	12N
6 signal +2 power	35N	23N	3N
15 signal +2 power	60N	39N	5N
24 signal +2 power	86N	56N	6N
30 signal +2 power	102N	66N	8N
42 signal +2 power	136N	88N	10N

## 2.5. Wire Termination Range

Recommended Wire Type ..... See Component Specification C049XX (latest issue)

Crimp Type	AWG Wire Size	Qty & Nominal diameter (mm) of strands	Minimum pull-off force	M22520/2-01 Crimp tool setting	Max. insulation diameter
Small Bore	<b>28</b>	7/0.125	12.5N	6	Ø1.10mm
	<b>26</b>	19/0.1	25.0N	6	
	<b>24</b>	7/0.2	44.0N	6	
Large Bore	<b>22</b>	19/0.15	50.0N	6	Ø1.80mm
Power	<b>20</b>	19/0.2	85.0N	8	
	<b>18</b>	19/0.25	140.0N	8	

**APPENDICES NOTES:**

1. Third angle projection is used where projected views are shown.
2. All dimensions are in millimetres.
3. For explanation of dimensions, etc. see BS8888.
4. Unless otherwise stated, all dimensions are maxima.

**APPENDIX 1 – CONTACT ORIENTATIONS**

These diagrams show pin numbers with reference to the polarization feature. They represent male and female connectors, shown looking onto the contact face. The contact designation shown below also appears on the non-mating (wiring) face of the connectors.

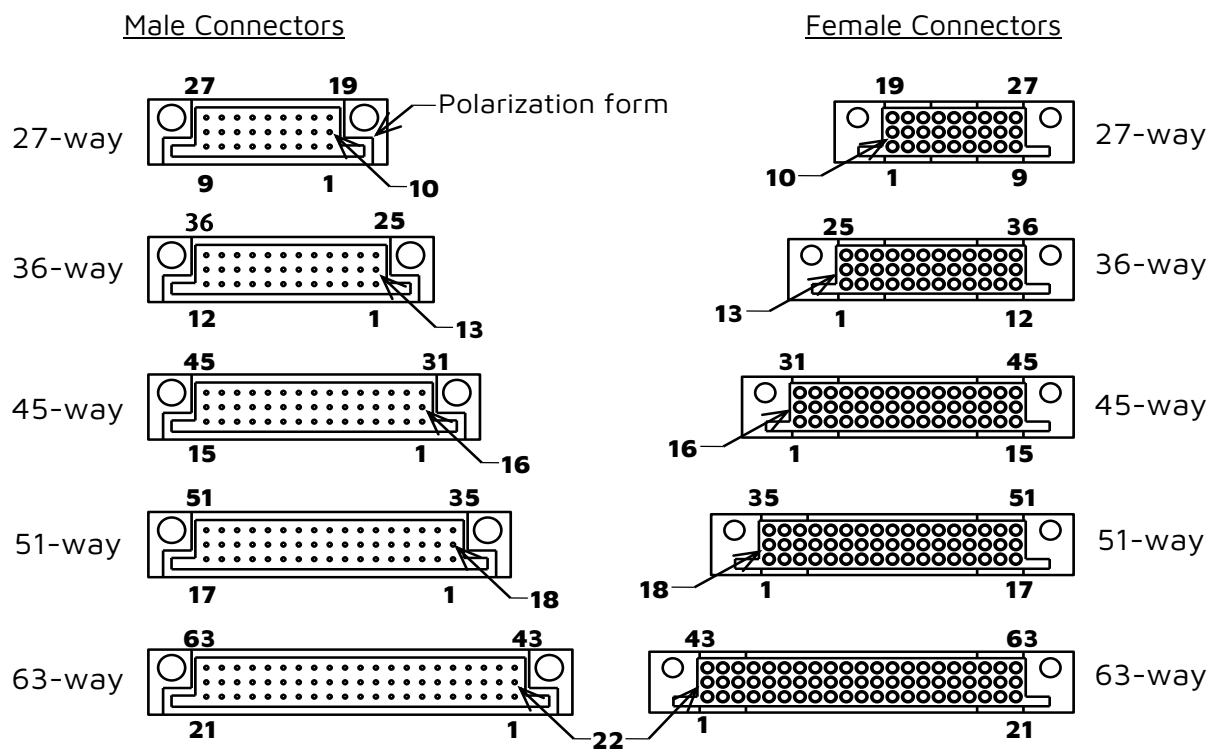
**A1.1. Signal Contacts**

## A1.2. Signal + Power Contacts

### Male Connectors

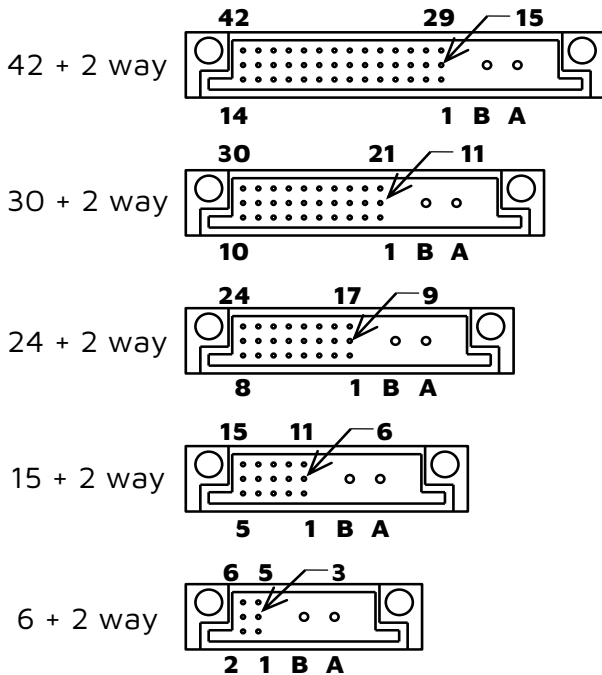

### Female Connectors

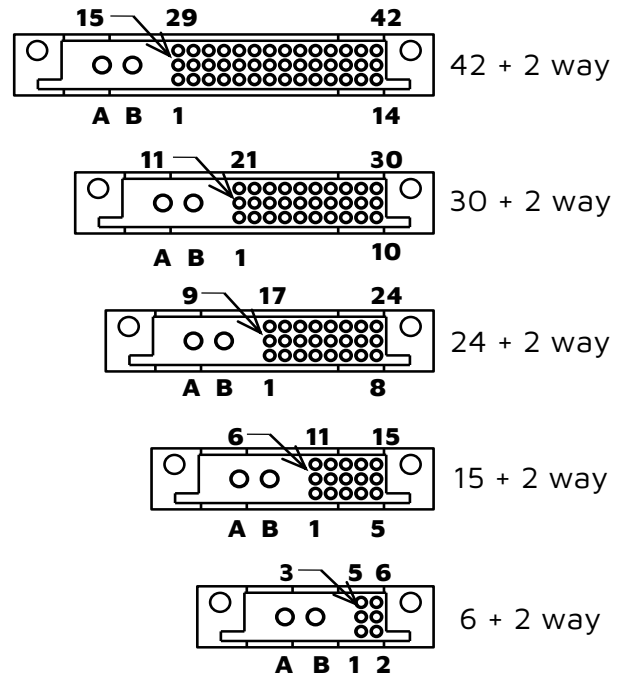

## APPENDIX 2 – INSTRUCTIONS FOR THE USE OF CONNECTORS FITTED WITH JACKSCREWS

Connectors are fitted with jackscrews where it is considered necessary to provide mechanical assistance in ensuring a satisfactory engagement and separation of the connector. This may apply in cases where engagement and separation forces are so high as to prevent satisfactory hand engagement, or where access to connector is restricted. Jackscrews also provide a locking feature, preventing the connector from disengaging under adverse conditions.

In order to obtain maximum effectiveness from the jackscrew system, the following rules for their use should be observed.

1. The connector with the fixed jackscrew should be fixed to the PCB by means of the male thread on the jackscrew, and an M2.5 nut. The nut should be tightened to a torque of **21±2cmN**.
2. On engaging the two halves of the connector after ensuring correct polarity, lightly push home the floating half until the jackscrews touch. Then, maintaining the pressure, turn one of the floating jackscrews clockwise, by means of a 2mm A/F hexagon key, until it engages with the fixed screw. Repeat with the other screw.

Then screw in each jackscrew, ensuring even loading by applying a maximum of one turn to each screw in sequence until the connector is bottomed. This will be evident by a sudden increase in the torque required on the screw. This torque should not exceed **23cmN**.

3. On disengaging the two halves of the connector turn each of the floating jackscrews anti-clockwise by means of the 2mm A/F hexagon key. Again, ensure even loading by turning each screw in sequence for a maximum of one turn until the jackscrew disengages. The connector can then be easily pulled apart.

**APPENDIX 3 – GAUGES**

**NOTES:**

1. Material = Steel to BS1407 or equivalent.
2. Gauging surfaces to be hardened/ground, 650 HV5 min.
3. These gauges to be used for testing fully assembled components only.
4. Ultimate wear limit 0.005mm is allowable on gauging dimensions.
5. Loading force to give 2Nm (Test prod only).

**A3.1. Test Prod**

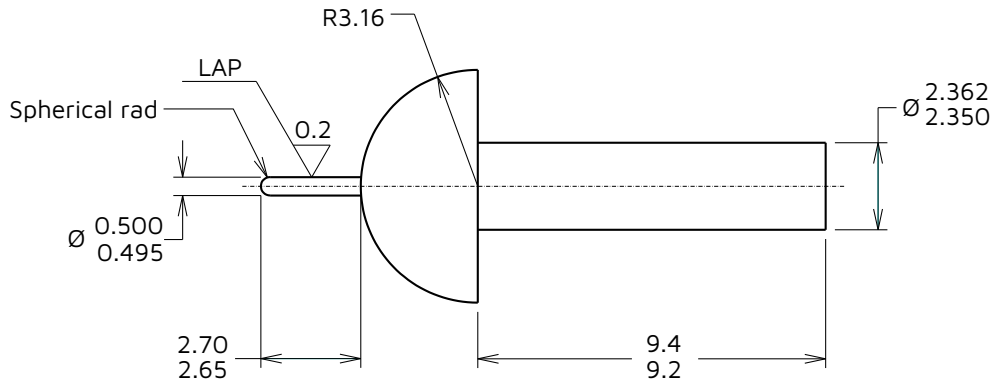

**A4.2. Sizing Gauge**

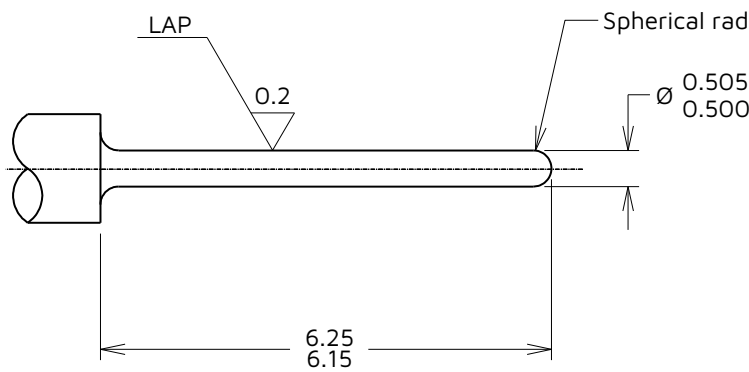

**A4.3. Holding Gauge**

