

VOLTAGE RANGE:200 to 600V

CURRENT:15 Ampere

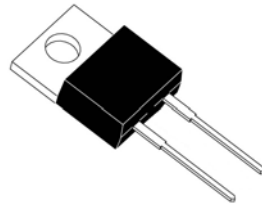

FEATURES

- * Low forward voltage drop
- * High current capability
- * High reliability
- * Low Power Loss, High Efficiency
- * Ultrafast 35 and 60 Nanosecond Recovery times

MECHANICAL DATA

- * Case: Molded plastic
- * Epoxy: UL 94V-0 rate flame retardant
- * Lead: Axial leads, solderable per MIL-STD-202, method 208 guaranteed
- * Polarity: Color band denotes cathode end
- * Mounting position: Any
- * Weight: 1.93 grams

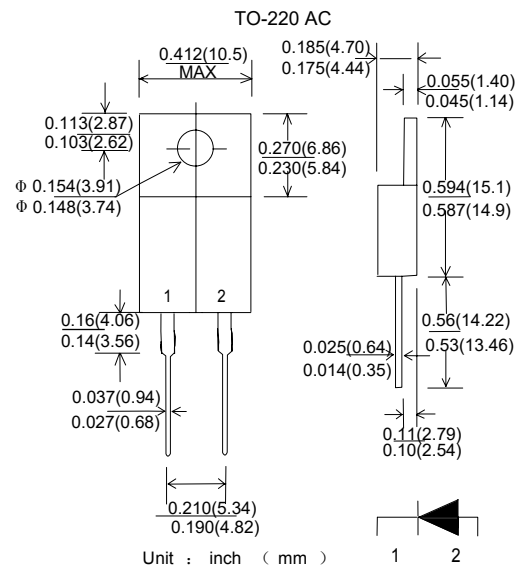

Maximum Ratings and Electrical Characteristics

- * Rating at 25 °C ambient temperature unless otherwise specified.
- * Single phase, half wave, 60 Hz, resistive or inductive load.
- * For capacitive load, derate current by 20%

Type Number	Symbol	MUR1520	MUR1540	MUR1560	Unit
Maximum Repetitive Peak Reverse Voltage	VRRM	200	400	600	V
Maximum RMS Voltage	VRMS	140	280	420	V
Maximum DC Blocking Voltage	VDC	200	400	600	V
Maximum Average Forward Rectified Current	IF	15			A
Peak Forward Surge Current, 8.3 ms Single Half Sine-wave Superimposed on Rated Load (JEDEC method)	IFSM	150			A
Maximum Instantaneous Forward Voltage @15A	VF	1.05	1.3	1.7	v
Maximum Reverse Current @ Rated VR TA=25 °C TA=125 °C	IR	10 500			uA
Typical Junction Capacitance (Note 1)	Cj	150			pF
Typical Thermal Resistance(Note 2)	RθJA	30			°C/w
Operating and Storage Temperature Range	TJ	-65~+150			°C
Maximum reverse recovery time (Note 3)	Trr	50			nS

NOTE1. Measured at 1.0 MHz and applied reverse voltage of 4.0V D.C.

NOTE2. Leads maintained at ambient temperature at a distance of 9.5mm from the case

NOTE3. Measured with IF = 0.5A, IR = 1.0A, IRR = 0.25A. See figure 5.

Typical Characteristics

FIG. 1 MAXIMUM FORWARD CURRENT DERATING CURVE

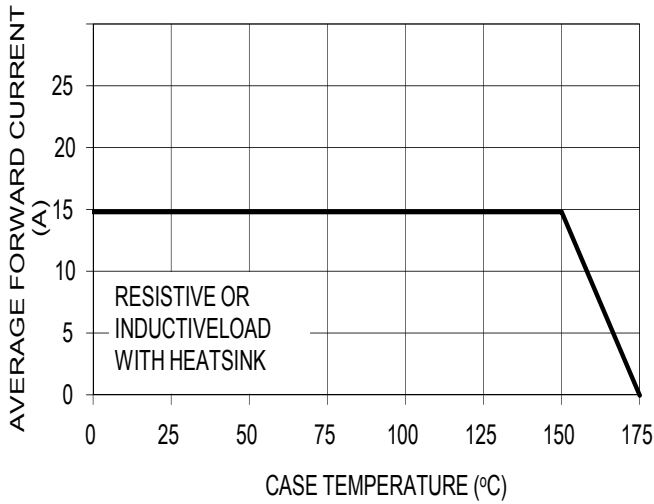

FIG. 2 MAXIMUM NON-REPETITIVE FORWARD SURGE CURRENT

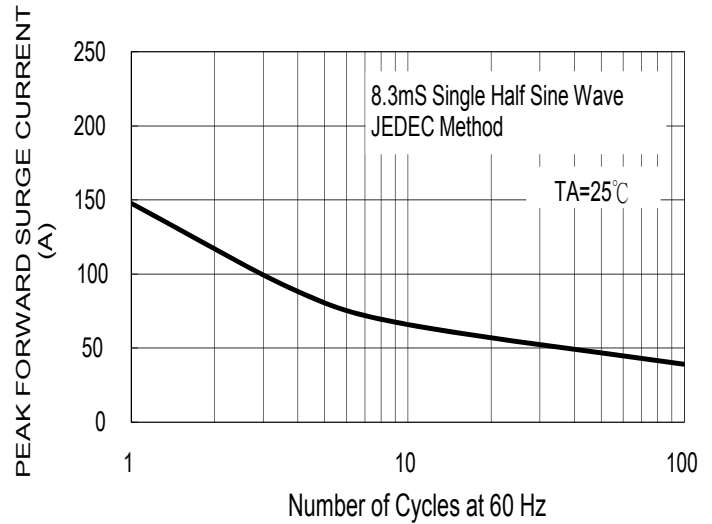

FIG. 3 TYPICAL INSTANTANEOUS FORWARD CHARACTERISTICS

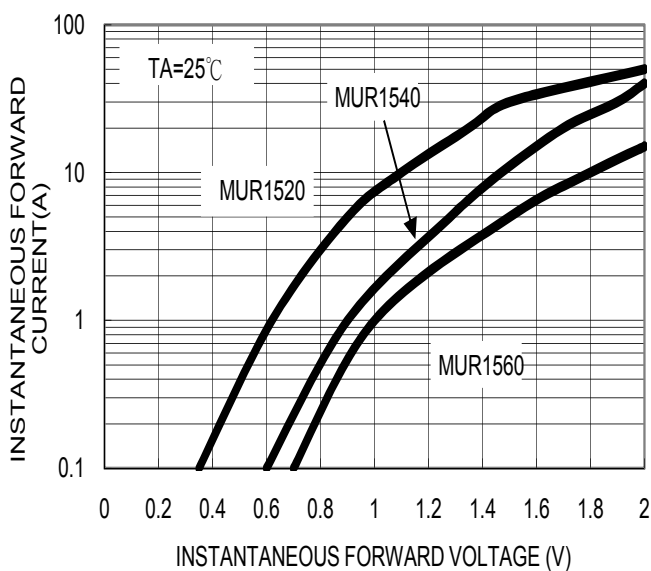

FIG. 4 TYPICAL REVERSE CHARACTERISTICS

