

Specifications:
 Current rating:1.0A AC,DC
 Voltage rating:50V AC, DC
 Contact resistance:20m ohm Max
 Insulation resistance:1,000M ohm Min
 Withstanding voltage:500V AC/minute
 Operating Temperature:-40°C ~ +105°C

Materials:
 Insulator:Nylon 9T(UL94V-0)
 Standard Color:Black
 Terminal:Brass
 Finish:Gold Plated

MATING PART
3230-XX-0103-00

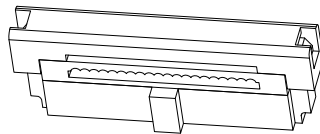

MATING PART
3230-XX-0104-00

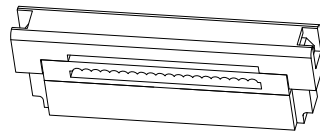

Dimension Information:

Pin.No	Dim.A	Dim.B	Dim.C	Pin.No	Dim.A	Dim.B	Dim.C
8	3.81	9.83	11.43	30	17.78	23.80	25.40
10	5.08	11.10	12.70	34	20.32	26.34	27.94
12	6.35	12.37	13.97	40	24.13	30.15	31.75
14	7.62	13.64	15.24	44	26.67	32.69	34.29
16	8.89	14.91	16.51	50	30.48	36.50	38.10
20	11.43	17.45	19.05	60	36.83	42.85	44.45
24	13.97	19.99	21.59	68	41.91	47.93	49.53
26	15.24	21.26	22.86				

RoHS Compliant

				DRAWN: Jamie	GENERAL TOLERANCE: .X=±0.25 .XX=±0.20	CnC Tech Industrial Cable and Connector Technology	DESCRIPTION: 1.27mm Box Header SMT Type	SIZE A4
				CHECKED: Jerry	UNIT: MM SCALE:1:1			
B	10-APR-2023			APPROVAL: Rory	SHEET: 1 / 2	PART NO: 3221-XX-0300-00		
A	05-FEB-2020				PROJECTION:			
REV	DATE	FILE	BY					

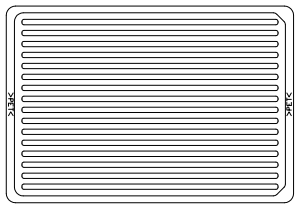

Bottom Tray

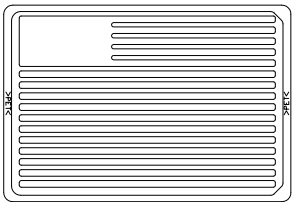

Bottom Tray

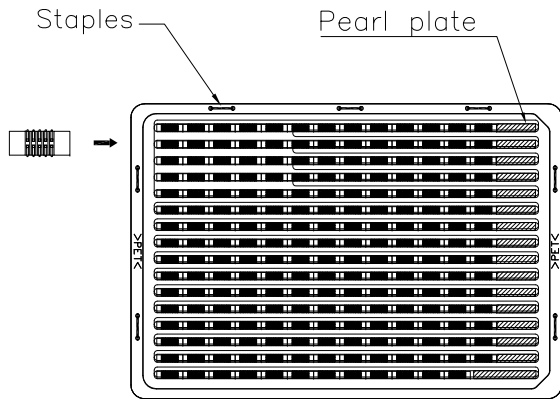

Tray layout

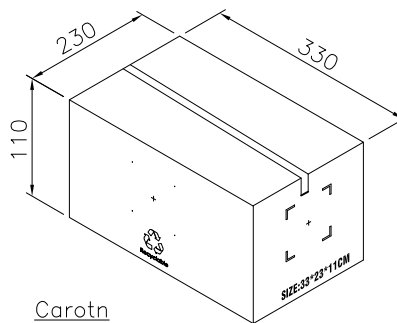
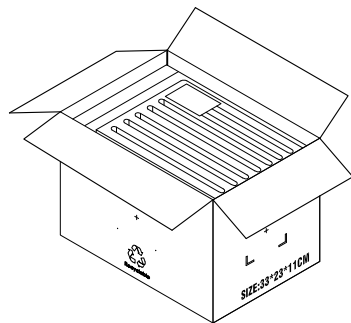
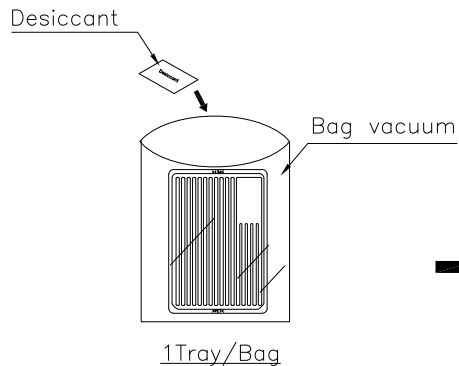

Carotn

Quantity:

Pin No.	Pcs/Tray	Q'TY
10	320	3200
14	260	2600
16	240	2400
20	220	2200
26	180	1800
40	120	1200
50	110	1100
60	90	900

Note:

1.Dimension:

Tray Size:314(L)x218(W)x8.7(H) (mm)
294(L)x218(W)x8.7(H) (mm)(Only 10Pin)
Cartron Size:330(L)x230(W)x110(H) (mm)

2.Quantity:

10 Trays/Cartron

3.CNC Tech recommends the following storage conditions for our SMD products in full factory packaging:

- (a) +18°C ~+28°C for temperature; relative humidity 30%~70%.
- (b) If stored in factory packaging in these conditions, we can guarantee the product to be free of moisture issues for up to a period of 1 year after delivery.
- (c) After one year, we recommend that the product be reinspected and baked if necessary.

We recommend that all of our SMD products be used in the reflow soldering process within 24 hours after opening factory packaging. If the product is not used up within 24 hours after opening, we recommend the parts be inspected and baked if necessary. Below are our recommendations for baking.

Product storage time and baking table

Product Material	Packing	Store Time	Baking Method
Nylon 9T	Tray	3 months	40°C 12Hrs (with tray)
	Reel	1 year	55°C 8Hrs (with tape & reel)
	Product can be baked directly		120°C 2Hrs

RoHS Compliant

				DRAWN: Jamie	GENERAL TOLERANCE: .X=±0.25 .XX=±0.20	CnC Tech Industrial Cable and Connector Technology	
				CHECKED: Jerry	UNIT: MM		
B	10-APR-2023				SCALE:1:1	1.27mm Box Header SMT Type	
A	05-FEB-2020			APPROVAL: Rory	SHEET: 2 / 2	PART NO:	SIZE A4
REV	DATE	FILE	BY		PROJECTION:	3221-XX-0300-00	