

REVISIONS					
P	LTR	DESCRIPTION	DATE	DWN	APVD
L		RESIN SUPPLIER CHANGE FOR THE HOUSING	15DEC2021	SCB	KJK

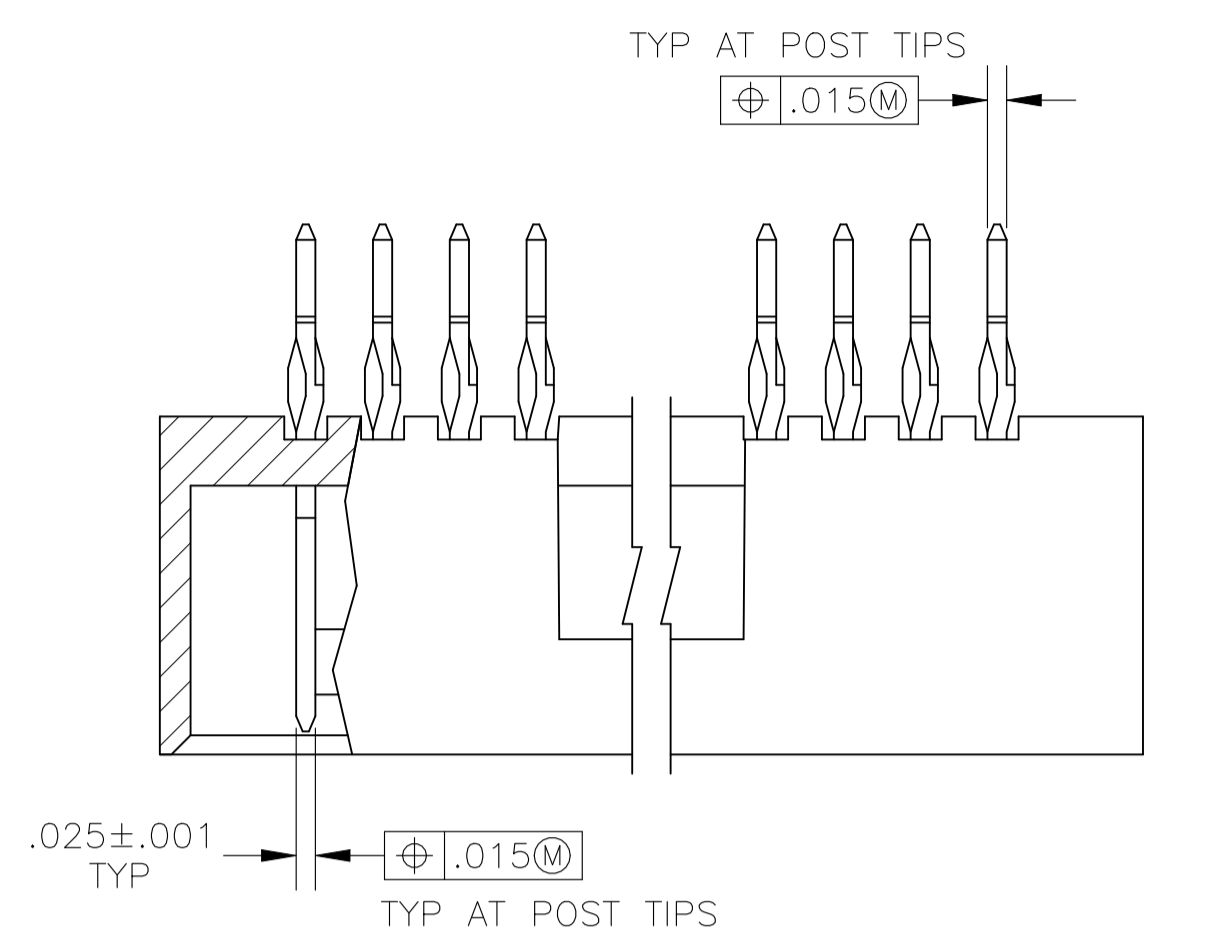

- 1 THE NOTED DIMENSIONS APPLY AT THE INTERSECTION OF THE POST AND HOUSING
- 2 POINT OF MEASUREMENT FOR PLATING THICKNESS
- 3 .000030 GOLD IN CONTACT AREA, .000100-.000200 MATTE TIN-LEAD ON THE SOLDER TAIL, ALL OVER .000050 NICKEL
- 4 .000030 GOLD IN CONTACT AREA, .000100-.000200 MATTE TIN ON THE SOLDER TAIL, ALL OVER .000050 NICKEL
- 5 OBSOLETE PARTS: OBSOLETE CIS STREAMLINING PER D.RENAUD/D.SINISI

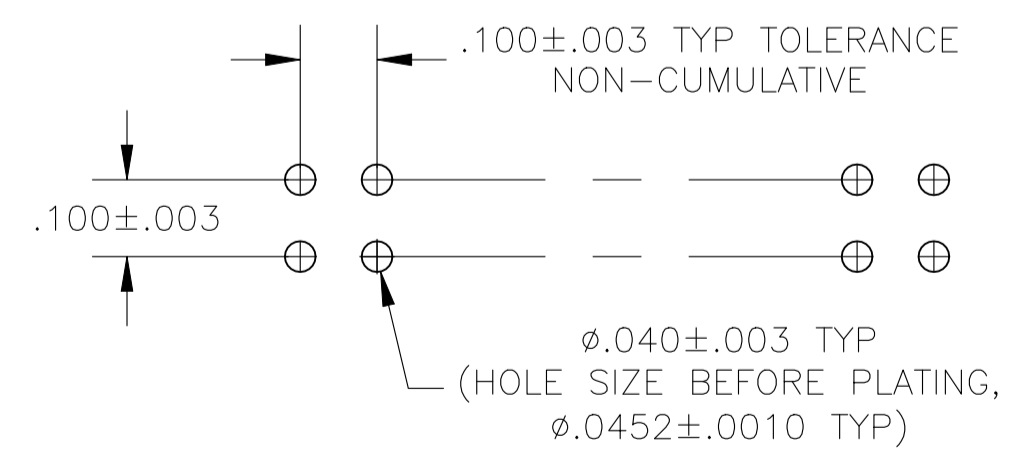
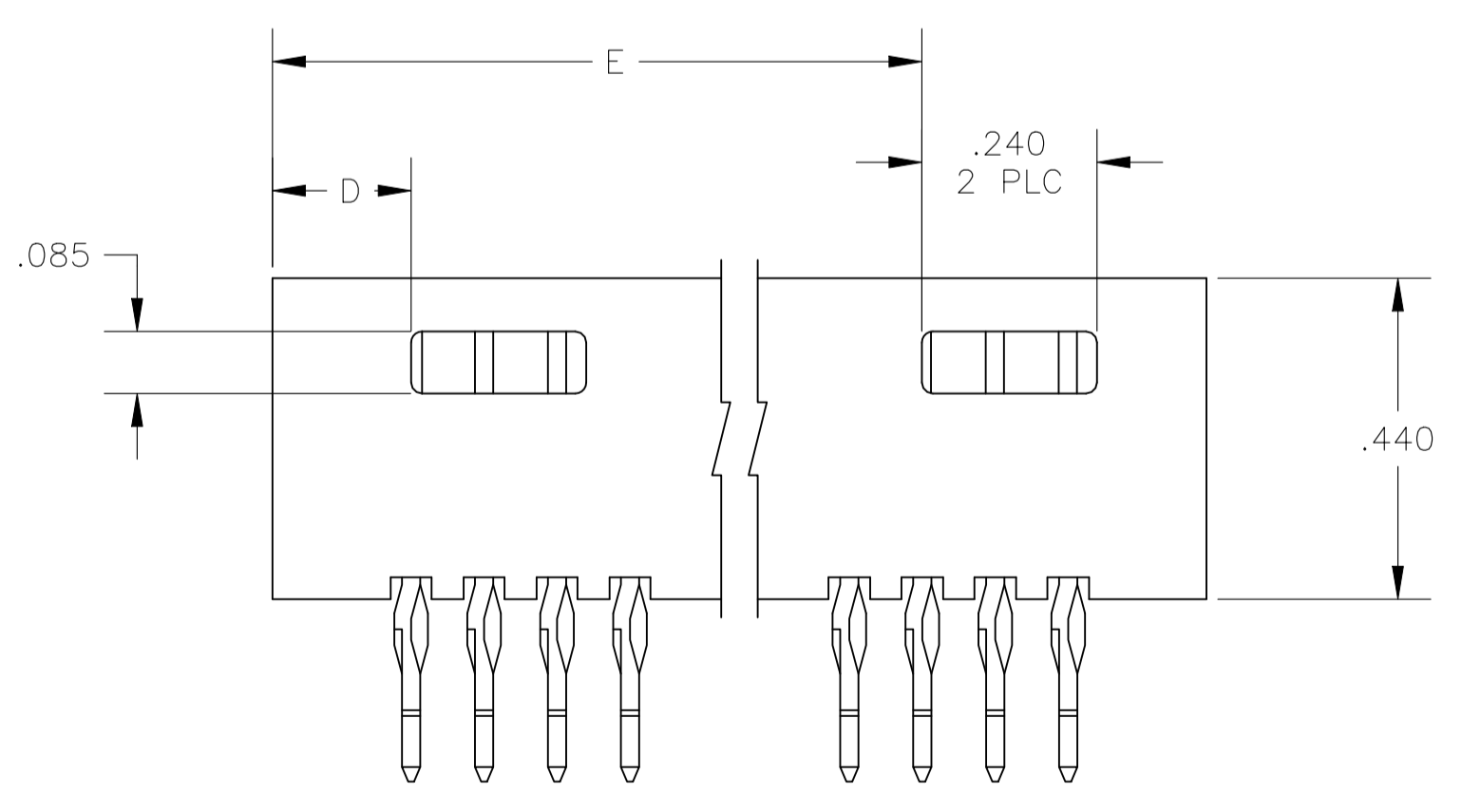
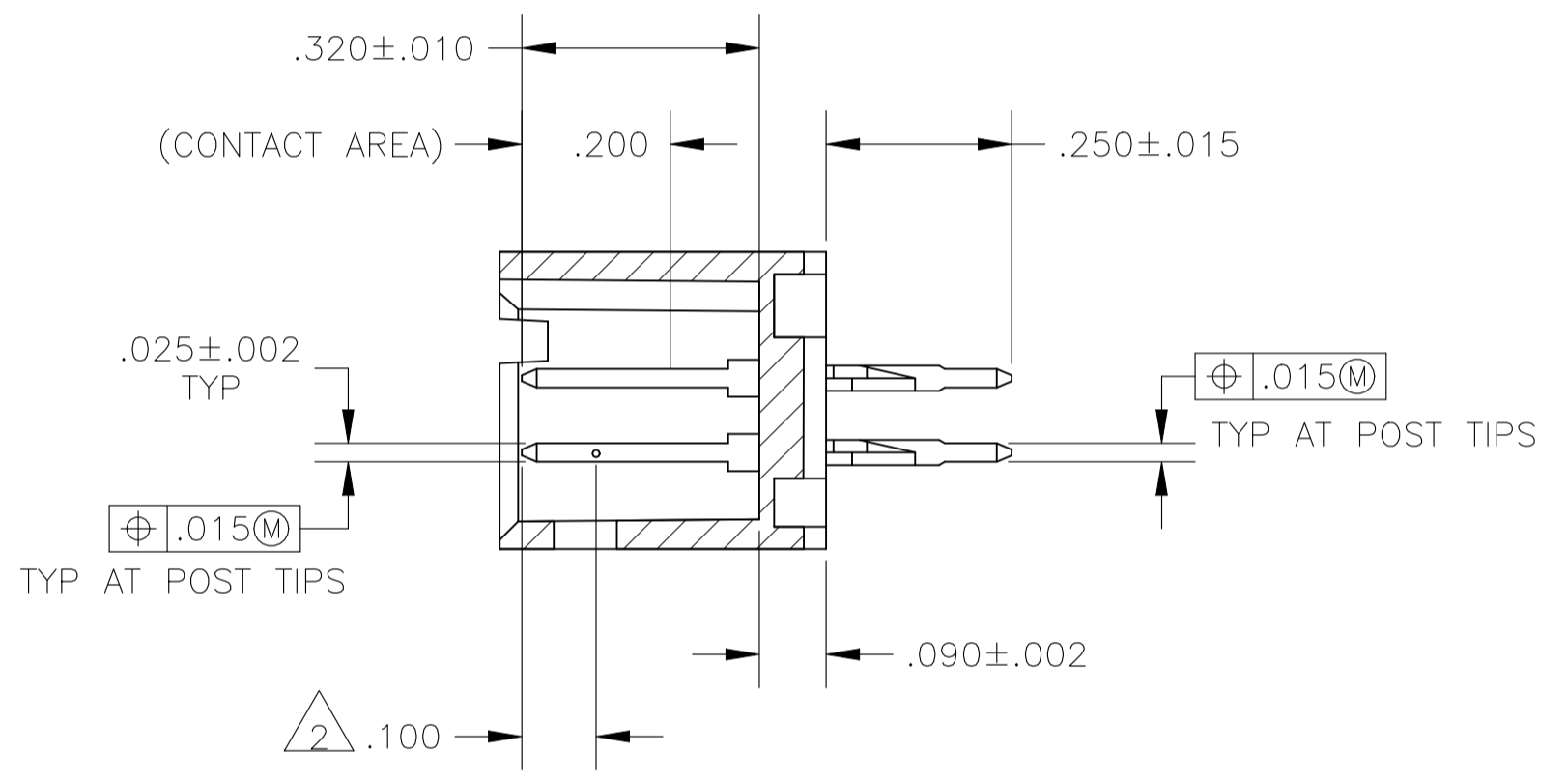
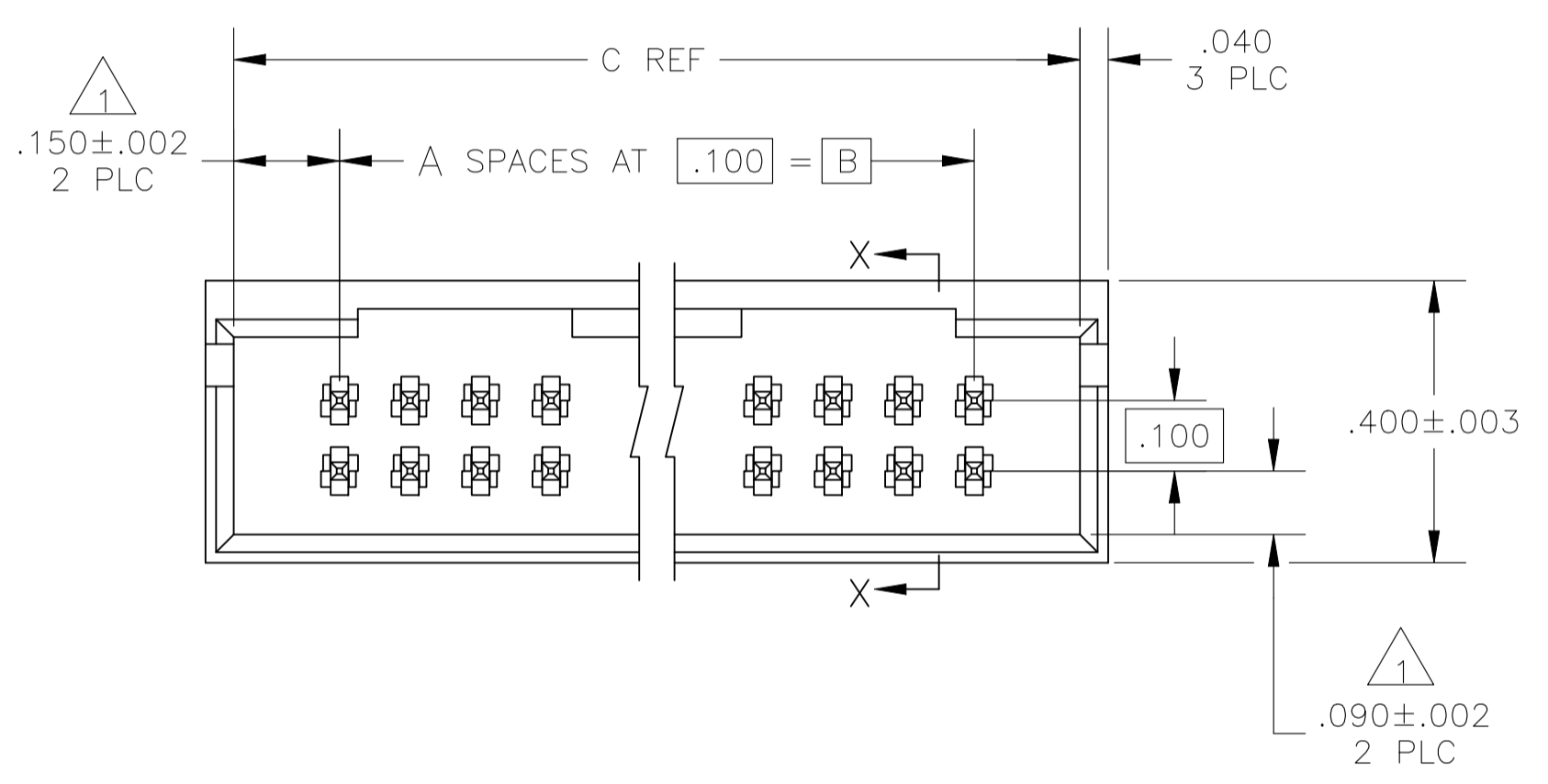

PLATING	E	D	C	B	A	NO OF POSN	ASSEMBLY PART NUMBER		
OBSOLETE	4	4	2.890	.190	3.200	2.900	29	60	-7-103337-8
OBSOLETE	4	4	1.890	.190	2.200	1.900	19	40	-6-103337-8
OBSOLETE	4	4	1.590	.190	1.900	1.600	16	34	6-103337-5
OBSOLETE	4	4	1.190	.190	1.500	1.200	12	26	6-103337-1
OBSOLETE	4	3	—	.390	1.000	.700	7	16	5-103337-6
OBSOLETE	3	3	2.890	.190	3.200	2.900	29	60	-2-103337-8
OBSOLETE	3	3	2.790	.190	3.100	2.800	28	58	2-103337-7
OBSOLETE	3	3	2.690	.190	3.000	2.700	27	56	2-103337-6
OBSOLETE	3	3	2.590	.190	2.900	2.600	26	54	2-103337-5
OBSOLETE	3	3	2.490	.190	2.800	2.500	25	52	2-103337-4
OBSOLETE	3	3	2.390	.190	2.700	2.400	24	50	2-103337-3
OBSOLETE	3	3	2.290	.190	2.600	2.300	23	48	2-103337-2
OBSOLETE	3	3	2.190	.190	2.500	2.200	22	46	2-103337-1
OBSOLETE	3	3	2.090	.190	2.400	2.100	21	44	2-103337-0
OBSOLETE	3	3	1.990	.190	2.300	2.000	20	42	1-103337-9
OBSOLETE	3	3	1.890	.190	2.200	1.900	19	40	1-103337-8
OBSOLETE	3	3	1.790	.190	2.100	1.800	18	38	1-103337-7
OBSOLETE	3	3	1.690	.190	2.000	1.700	17	36	1-103337-6
OBSOLETE	3	3	1.590	.190	1.900	1.600	16	34	1-103337-5
OBSOLETE	3	3	1.490	.190	1.800	1.500	15	32	1-103337-4
OBSOLETE	3	3	1.390	.190	1.700	1.400	14	30	1-103337-3
OBSOLETE	3	3	1.290	.190	1.600	1.300	13	28	1-103337-2
OBSOLETE	3	3	1.190	.190	1.500	1.200	12	26	1-103337-1
OBSOLETE	3	3	1.090	.190	1.400	1.100	11	24	1-103337-0
OBSOLETE	3	3	.990	.190	1.300	1.000	10	22	103337-9
OBSOLETE	3	3	.890	.190	1.200	.900	9	20	103337-8
OBSOLETE	3	3	—	.490	1.100	.800	8	18	103337-7
OBSOLETE	3	3	—	.390	1.000	.700	7	16	103337-6
OBSOLETE	3	3	—	.290	.900	.600	6	14	103337-5
OBSOLETE	3	3	—	.190	.800	.500	5	12	103337-4
OBSOLETE	3	3	—	.290	.700	.400	4	10	103337-3
OBSOLETE	3	3	—	.190	.600	.300	3	8	103337-2
OBSOLETE	3	3	—	.190	.500	.200	2	6	103337-1

THIS DRAWING IS A CONTROLLED DOCUMENT.

DIMENSIONS: INCHES	TOLERANCES UNLESS OTHERWISE SPECIFIED:	0 PLC ± -	1 PLC ± -	2 PLC ± -	3 PLC ± -	4 PLC ± -	ANGLES ± -
--------------------	--	-----------	-----------	-----------	-----------	-----------	------------

MATERIAL: HOUSING: FLAME RETARDANT THERMOPLASTIC, COLOR-BLACK; POSTS: CU-NI-SN; FINISH: SEE TABLE

WEIGHT: —; SIZE: A1; CAGE CODE: 00779; DRAWING NO: 103337; SCALE: 4:1; SHEET: 1 of 1; REV: L

TE Connectivity logo and name.

HDR ASSY, MOD II, COMPLIANT PIN, DBL ROW, .100X.100 C/L, 4 SIDED SHROUD