

uLCD-144-G2



Datasheet

Revision 1.6

Copyright © 2023 4D Systems

Content may change at any time. Please refer to the resource centre for latest documentation.

Contents

1. Description	3
2. Features	4
3. Pin Configuration and Summary	5
4. Hardware Interface - Pins	6
4.1. Serial Ports - COM0 UART	6
4.2. General Purpose I/O	7
4.3. System Pins	11
5. Module Features	12
5.1. Display - 1.44" LCD TFT	12
5.2. Goldelox Processor	13
5.3. SD/SDHC Memory Cards	13
6. Display Precautions	14
7. Hardware Tools	15
7.1. 4D Programming Cable/Adaptor	15
8. Programming Language	16
9. Workshop4 IDE	17
9.1. PmmC/Firmware Programming	18
10. Display Module Part Numbers	18
11. Starter Kit	19
12. Mechanical Details	20
13. Schematic Diagram - REV 5.0	21
14. Specifications	22
15. Revision History	24

1. Description

The uLCD-144G2 is a nifty little display module in the 4D Systems micro LCD graphics display range. Combining a resolution of 1.44" 128x128 pixels with 65K True to Life colours, this display module is perfect for animations, slideshows and other multimedia presentations. It is the ideal size for attractive embedded display applications.

This module is compact and cost-effective and features a 1.44" LCD TFT screen, which is the smallest LCD TFT module available from 4D Systems. Driving the module and its peripherals is the GOLDELOX processor, a very capable chip that provides impressive graphics power, programmed with 4D Systems Workshop IDE Software.

4D Systems Workshop enables graphic solutions to be constructed rapidly and with ease due to its design being solely for 4D graphics controllers.

The uLCD-144G2 has a modest but comprehensive range of features suited for an application requiring a bright eye-catching display, an analog input, Dallas 1-wire sensor capability, audio generation, or simply digital I/O. This is truly an impressive little module.

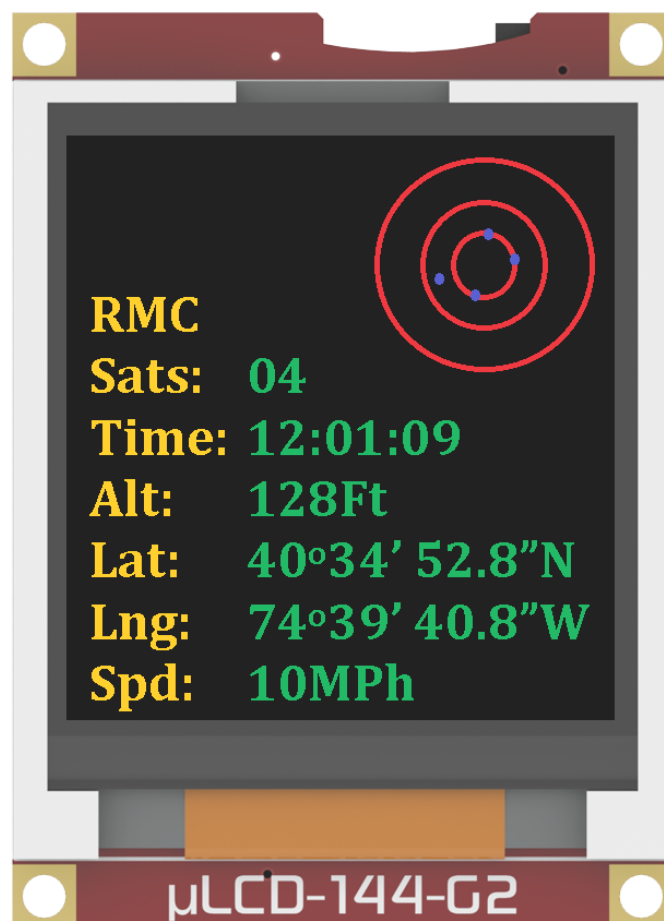

2. Features

- Low-cost 1.44" OLED display graphics user interface solution.
- 128 x 128 resolution, RGB 65K true to life colours, PMOLED Screen.
- LED backlighting with a greater than 150° viewing angle.
- Easy 10 pin interface to any host device: 3.3Vout, IO2, GND, IO1, RESET, GND, RX, TX, +5V, 5V OUT
- Powered by the 4D-Labs GOLDELOX processor (also available as a separate OEM IC).
- 10KB of flash memory for user code storage and 510 bytes of RAM for user variables (255 x 16bit vars).
- Asynchronous hardware serial UART port with auto-baud, TTL interface, with 300 to 600K baud
- 2 x General Purpose I/O pins.
- IO1 supports:
 - Digital I/O
 - A/D Converter with 8/0 bit resolution
 - Complex sound generation
 - Dedicated RTTTL tune engine
 - Multi-Switch Joystick, Buttons
 - Dallas 1-Wire
- IO2 supports:
 - Digital I/O
 - Complex sound generation
 - Dedicated RTTTL tune engine
 - Dallas 1-Wire
- On-board micro-SD memory card adaptor for multimedia storage and data logging purposes. HC memory card support is also available for cards larger than 4GB.
- Built-in extensive 4DGL graphics and system library functions
- Display full colour images, animations, icons and video clips (no audio support for video).
- Supports all available Windows fonts and characters (imported as external fonts).
- 4.0V to 5.5V range operation (single supply), nominal 5.0V.
- Module dimensions: 31.0 x 42.0 x 14 mm (including header pins)
- Weight ~ 10g.
- Display Viewing Area: 25.5 x 26.5 mm
- RoHS Compliant.

3. Pin Configuration and Summary

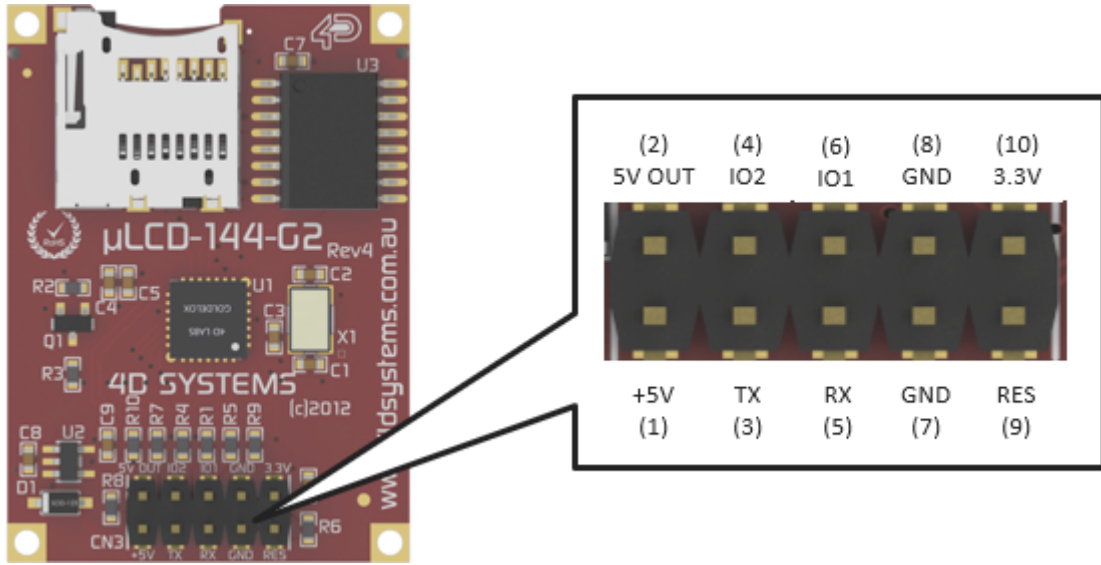

Interface/Programming Header			
Pin	Symbol	I/O	Description
1	+5V	P	Main Voltage Supply +ve input pin. Reverse polarity protected. The range is 4.0V to 5.5V, nominal 5.0V.
2	5V OUT	P	5V OUT provides approximately 4.7 V through a protection diode.
3	TX	O	Asynchronous Serial Transmit pin. Output data is at TTL voltage levels. Connect this pin to the external device Serial Receive (Rx) signal. This pin is tolerant up to 5.0V levels.
4	IO2	I/O	General purpose IO2 pin. See the [General Purpose I/O] section for more details.
5	RX	I	Asynchronous Serial Receive pin. Connect this pin to the external device Serial Transmit (Tx) signal. This pin is tolerant up to 5.0V levels.
6	IO1	I/O	General purpose IO1 pin. See the [General Purpose I/O] section for more details.
7	GND	P	Supply Ground.
8	GND	P	Supply Ground.
9	RESET	I	Master Reset signal. Internally pulled up to 3.3V via a 4.7K resistor. An active Low pulse greater than 2.0µs will reset the module. If the module needs to be reset externally, only use open collector-type circuits. This pin is not driven low by any internal conditions. The host should control this pin via one of its port pins using an open collector/drain arrangement.
10	3.3V	P	Regulated 3.3 Volts output, maximum available current 50mA to power external circuitry.

Note
I = Input, **O** = Output, **P** = Power

4. Hardware Interface - Pins

The uLCD-144G2 provides both a hardware and software interface. This section describes in detail the hardware interface pins of the device.

4.1. Serial Ports - COM0 UART

The uLCD-144G2 has a dedicated hardware UART that can communicate with external serial devices.

The primary features are:

- Full-Duplex 8-bit data transmission and reception through the TX and RX pins.
- Data format: 8 bits, No Parity, 1 Stop bit.
- Auto Baud feature.
- Baud rates from 300 baud up to 600K baud.

The Serial port is also the primary interface for downloading compiled 4DGL application code as well as future PmmC/Firmware updates for the onboard GOLDELOX processor. Refer to the [PmmC/Firmware Programming](#) section for more details.

TX pin 3 (Serial Transmit):

Asynchronous Serial port Transmit pin, TX. The serial output data is at TTL voltage levels. Connect this pin to the external serial device Rx signal.

Rx pin 5 (Serial Receive):

Asynchronous Serial port Receive pin, RX. Connect this pin to an external serial device Transmit Tx signal.

4.2. General Purpose I/O

There are 2 GPIO pins available, IO1 and IO2. Each GPIO has a multitude of high-level functions associated with it and these can be selected within the 4DGL user application code.

Refer to the [Goldelox Internal Functions Manual](#) manual for a complete set of built-in 4DGL library functions.

IO1 pin 6 (General Purpose IO1):

General purpose IO1 pin. The following table lists the available GPIO functions and features.

IO2 pin 4 (General Purpose IO2):

General purpose IO2 pin. The following table lists the available GPIO functions and features

Note

Digital GPIO pins are 5.0V tolerant

GPIO Functions and Features

Function	IO1	IO2
Digital Input	Yes	Yes
Digital Output	Yes	Yes
A/D Converter 8/10 bits	Yes	
Joystick -- 5 position multi-switch	Yes	
Dallas 1-Wire support	Yes	Yes
Sound Generation, RTTL Tune	Yes	Yes

Input/Output:

Both IO1 and IO2 pins can be programmed to be Inputs or Outputs. The diagram below shows a LED connected to IO1 (programmed as an output) and a button connected to IO2 (programmed as an input).

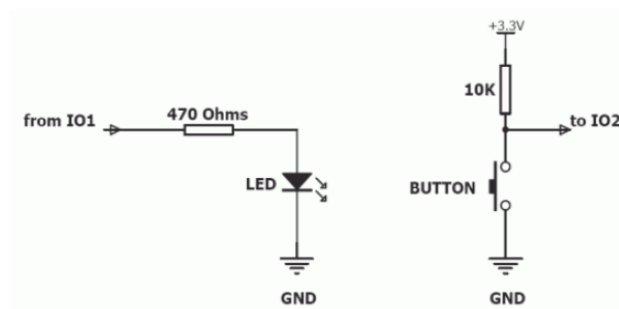

Joystick - Multi Switch:

Multiple buttons or a multi-switch Joystick can be connected to the IO1 pin on the uLCD-144G2 module. Up to five buttons or a 5 position multi-switch joystick connects to a junction of a resistor ladder network that forms a voltage divider. The A/D converter of the IO1 pin internally reads the analogue value and decodes it accordingly. This feature is supported by dedicated 4DGL library functions. The following diagrams indicate how to connect up to five individual buttons or a multi switch joystick to the IO1 pin.

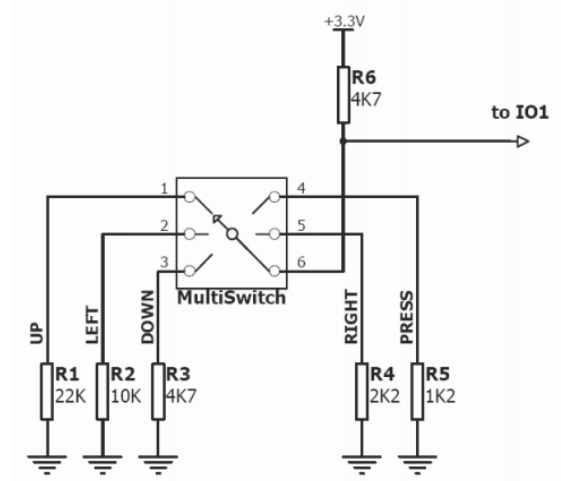
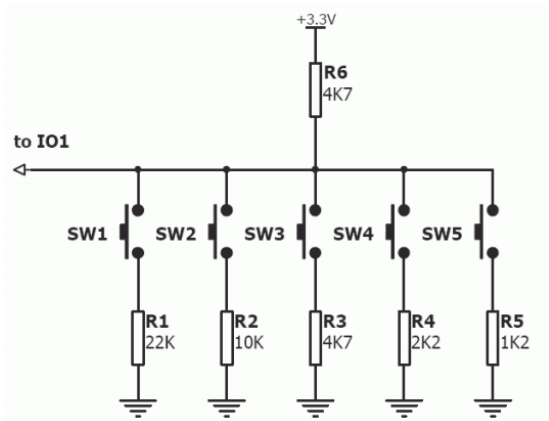

Unused buttons do not need resistors to be connected to the circuit. The table below lists the buttons and corresponding resistor values.

GPIO Functions and Features		
Number of Buttons	Button Number	Resistor Value
1	SW1	22K
2	SW2	10K
3	SW3	4.7K
4	SW4	2.2K
5	SW5	1.2K

Analogue to Digital Converter:

The IO1 pin can be programmed as an A/D input. The option is available to select 8-bit or 10-bit resolution. The diagram below is a circuit of a Light Dependent Resistor (LDR) connected to IO1 to measure and record changes in ambient light.

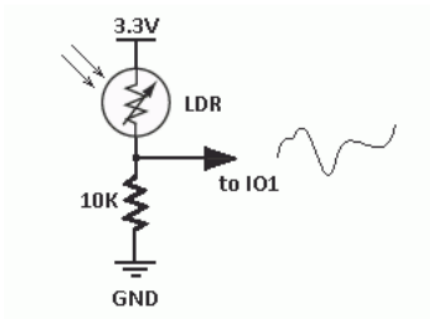

Dallas 1-Wire

The Dallas 1-Wire protocol is a form of serial communication designed to operate over a single data line plus ground reference. Multiple 1 Wire devices can be attached to the same shared data line to network many devices. One wire device support is available on both the IO1 and the IO2 pins on the uLCD-144G2 module.

The following diagram depicts a typical 1-Wire temperature sensor interface.

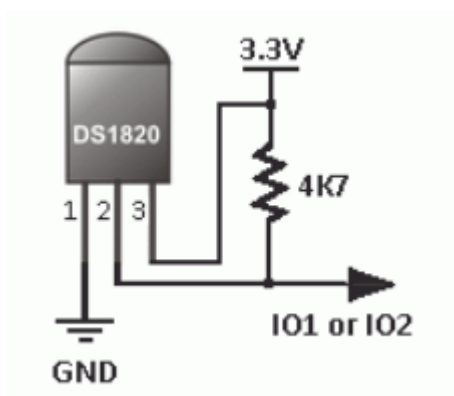

Sound Output:

The uLCD-144G2 module is capable of generating complex sounds and RTTL tunes from its IO1 and IO2 pins. A simple speaker circuit as shown below can be used.

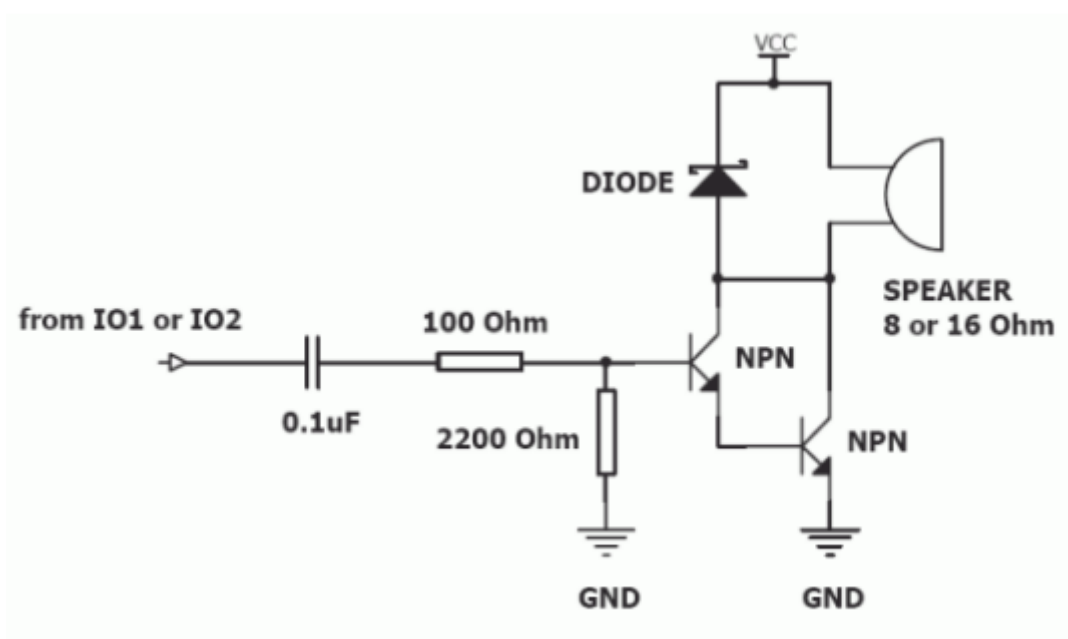

4.3. System Pins

+5V (Module Voltage Input):

Pin 1:

Module supply voltage input pin. This pin must be connected to a regulated supply voltage in the range of 4.0 Volts to 5.5 Volts DC. The nominal operating voltage is 5.0 Volts.

5V Out(~4.7V):

Pin 2:

External circuitry that requires approximately a 5V supply can be powered up via this pin. The maximum available current is 50 mA.

GND (Module Ground):

Pins 7, 8:

Device ground pins. These pins must be connected to the ground.

RESET (Module Master Reset):

Pin 9:

Module Master Reset pin. An active low pulse of greater than 2 micro-seconds will reset the module. Internally pulled up to 3.3V via a 4.7K resistor. Only use open collector-type circuits to reset the device if an external reset is required.

3.3 Vout (3.3V Regulated Output):

Pin 10:

External circuitry that requires a regulated 3.3 V supply can be powered up via this pin. The maximum available current is 50mA.

5. Module Features

The uLCD-144G2 module is designed to accommodate most applications. Some of the main features of the module are listed below.

5.1. Display - 1.44" LCD TFT

The uLCD-144G2 is equipped with a full-colour LCD TFT screen. Some of the features of the screen are:

- Screen Size: 1.44" diagonal
- 128 x 128 Resolution LCD TFT display
- Screen Dimensions: 30.9 x 36.5 mm.
- Viewing Area: 25.5 x 26.5 mm
- 65K true-to-life colours
- Luminance: 250 cd/m²
- Contrast Ratio: 450
- Viewing Angle: > 150 degrees
- LED Backlighting



Note

The Displays used are the highest-rated 'Grade A' Displays, which allow for 0-4 defective pixels. A defective pixel could be solid Black (Dead), White, Red, Green or Blue

5.2. Goldelox Processor

The module is designed around the GOLDELOX Graphics Processor from 4D-Labs

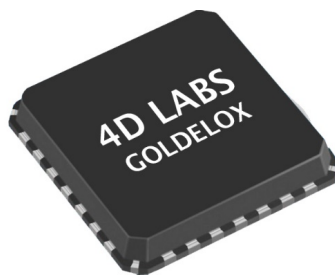

The GOLDELOX is a custom-embedded graphics processor designed to interface with many popular OLED and LCD panels. Powerful graphics, text, images, animation and countless more features are built right inside the chip. It offers a simple plug-and-play interface to many 8-bit 80-Series colour LCD and OLED displays.

The chip is designed to work with minimal design effort and all of the data and control signals are provided by the chip to interface directly with the display. Simply choose your display and interface it to the GOLDELOX on your application board. This offers enormous advantages to the designer in development time and cost saving and takes away all of the burdens of low-level design.

Refer to the [Goldelox Processor datasheet](#) for more information.

5.3. SD/SDHC Memory Cards

The module supports micro-SD memory cards via the onboard micro-SD connector. The memory card is used for all multimedia file retrieval such as images, animations and movie clips. The memory card can also be used as general-purpose storage for data logging applications. Support is available for off-the-shelf micro-SD and high capacity HC memory cards (4GB and above).

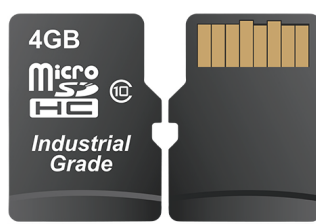

Note

A microSD card capable of SPI is a requirement for all 4D Systems' display modules powered by Goldelox, Picaso or Diablo16 Processors. If a non-SPI compatible card is used, it will simply fail to mount, or may cause intermittent issues resulting in lockups and crashing of the application. Please refer to the 4D Systems website for microSD cards offered by 4D Systems.

6. Display Precautions

- Avoid having to display the same image/object on the screen for lengthy periods. This will cause a burn-in which is a common problem with all types of display technologies. Blank the screen after a while or dim it very low by adjusting the contrast. Better still; implement a screen saver feature.
- Moisture and water can damage the display. Moisture on the surface of a powered display will cause the electrodes to corrode. Wipe off any moisture gently or let the display dry before usage.
- Dirt from fingerprint oil and fat can easily stain the surface of the display. Gently wipe off any stains with a soft lint-free cloth.
- The performance of the display will degrade under high temperatures and humidity. Avoid such conditions when storing.
- Do not tamper with the display flex cable that is connected to the control board. This may affect the connection between the display and the driving circuitry and cause failure.
- Displays are susceptible to mechanical shock and any force exerted on the module may result in deformed zebra strips and cracks, a cracked display cell and a broken backlight.
- Always use the mounting holes on the module's printed circuit board to mount the display.

7. Hardware Tools

The following hardware tools are required for full control of the uLCD-144G2 module.

7.1. 4D Programming Cable/Adaptor

The 4D Programming Cable and uUSB-PA5-II Programming Adaptor are essential hardware tools to program, customise and test the GOLDELOX Processor. Either the 4D Programming Cable or the uUSB-PA5-II Programming Adaptor can be used.

The 4D programming interfaces are used to program a new Firmware/PmmC, Display Driver and for downloading compiled 4DGL code into the processor. They even serve as an interface for communicating serial data to the PC.

The 4D Programming Cable and uUSB-PA5-II Programming Adaptor are available from the [4D Systems website](#). Using a non-4D programming interface could damage your processor, and **void your Warranty**.



4D Programming Cable

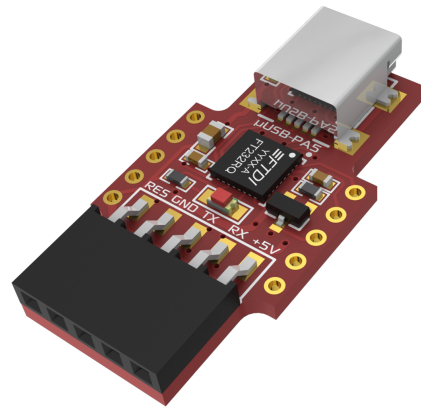

uUSB-PA5-II Programming Adaptor

8. Programming Language

The heart of the uLCD-144G2 module is the GOLDELOX graphics processor from 4D Labs. The GOLDELOX belongs to a family of processors powered by a highly optimised softcore virtual engine, EVE (Extensible Virtual Engine).

EVE is a proprietary, high-performance virtual machine with an extensive byte-code instruction set optimised to execute compiled 4DGL programs. 4DGL (4D Graphics Language) was specifically developed from the ground up for the EVE engine core. It is a high-level language that is easy to learn and simple to understand yet powerful enough to tackle many embedded graphics applications.

4DGL is a graphics-oriented language allowing rapid application development, and the syntax structure was designed using elements of popular languages such as C, Basic, Pascal and others.

Programmers familiar with these languages will feel right at home with 4DGL. It includes many familiar instructions such as `IF..ELSE..ENDIF`, `WHILE..WEND`, `REPEAT..UNTIL`, `GOSUB..ENDSUB`, `GOTO`, `PRINT` as well as some specialised instructions `SERIN`, `SEROUT`, `GFX_LINE`, `GFX_CIRCLE` and many more.

For detailed information about the 4DGL language, please refer to the following documents:

- [4DGL Programmers Reference Manual](#)
- [Goldelox Internal Functions Manual](#)

To assist with the development of 4DGL applications, the Workshop4 IDE combines a full-featured editor, a compiler, a linker and a downloader into a single PC-based application. It's all you need to code, test and run your applications.

4DGL is available to be written in two of the four environments offered by the Workshop4 IDE, Designer and ViSi. The other two environments, Serial and ViSi-Genie do not directly use 4DGL by the User (Except in Workshop4 Pro, for ViSi-Genie), however, it is present in the background. Serial is an application that runs, and that is written in 4DGL. ViSi-Genie automatically generates 4DGL itself based on what is configured in the GUI.

9. Workshop4 IDE

Workshop4 is a comprehensive software IDE that provides an integrated software development platform for all of the 4D family of processors and modules. The IDE combines the Editor, Compiler, Linker and Downloader to develop complete 4DGL application code. All user application code is developed within the Workshop4 IDE.



The Workshop4 IDE supports multiple development environments for the user, to cater to different user requirements and skill levels.

- The **Designer** environment enables the user to write 4DGL code in its natural form to program the range of 4D Systems' intelligent displays.
- A visual programming experience, suitably called **Visi**, enables drag-and-drop type placement of objects to assist with 4DGL code generation and allows the user to visualise how the display will look while being developed.
- An advanced environment called **Visi-Genie** doesn't require any 4DGL coding at all, it is all done automatically for you. Simply lay the display out with the objects you want, set the events to drive them and the code is written for you automatically. This can be extended with additional features when a Workshop4 PRO license is purchased from the 4D Systems website. Extended Advanced features for Visi-Genie are available in the PRO version of WS4. Further details are explained under the [Visi Genie](#) section of the Workshop4 documentation.
- A **Serial** environment (aka SPE 'Serial Platform Environment') is also provided to transform the display module into a slave serial module, allowing the user to control the display from any host microcontroller or device with a serial port using predefined serial commands.

For more information regarding these environments, refer to the [Workshop4 manuals](#).

The Workshop4 IDE is available from the [4D Systems website](#).

9.1. PmmC/Firmware Programming

The Goldelox processor on the uOLED-128-G2 module can be reprogrammed with the latest PmmC configuration for updates and future-proofing. The chip-level configuration is available as a PmmC (Personality-module-micro-Code) file and the programming must be performed over the serial interface. The chip-resident internal 4DGL functions are part of the GOLDELOX PmmC configuration file so please check regularly for the latest updates and enhancements.

The PmmC file is programmed into the device with the aid of Workshop4, the 4D Systems IDE software (See [Starter Kit](#)). To provide a link between the PC and the ICSP interface, a specific 4D Programming Cable is required and is available from 4D Systems.

Using a non4-D programming interface could damage your display, and **void your Warranty**.

10. Display Module Part Numbers

The following is a breakdown of the part numbers and what they mean.

Example:

· uLCD-144G2

uLCD - microLCD Display Family

144 - Display size (1.44")

G - Goldelox Processor

2 - Generation 2

11. Starter Kit

4D Systems highly recommends all first-time buyers of 4D Systems' displays, to purchase the Starter Kit when purchasing their first 4D Systems display solution.

The Starter Kit provides all the hardware that is required to get the User up and running.

Not all development environments and features will be needed by every User. However, purchasing the display solution in a Starter Kit allows you to take full advantage of all of the features of the 4D Systems Display Solution and try out each of the 4D Workshop4 Environments before settling with the preferred feature set.

The **Designer** environment can use every feature of the display, however, depending on the user requirements, a micro-SD (uSD) card may not be required. The uSD card is used when displaying images/video/sound, along with data logging to uSD, and a programming cable or adaptor is required for downloading compiled code and PmmC/Firmware updates.

The **Visi** environment is the same as Designer in terms of feature utilisation, but is image based so requires a uSD card, along with a programming cable.

The **Serial** environment does not require either a uSD or Programming cable to be used once the module has been configured as a Serial device, however, can use both depending on the user's requirements. The uSD card can be used for such things as storage and display of multimedia files, data logging, and the Programming cable for PmmC/Firmware updates, or changing to one of the other three programming environments.

Starter Kits typically include:

- uLCD-144-G2 Display Module
- uUSB-PA5-II Programming Adaptor
- 4GB micro-SD Card
- 5-way Male to Male adaptor (for converting the Female-Female cable to be Male-Female)
- 150mm 5 way Female-Female jumper cable, for quick connection to another device or breadboard
- Quick Start Guide

Please refer to the [4D Systems website](#) for the current components included in the Starter Kit.

Simply select the Starter Kit option when purchasing the chosen display module on the 4D Systems shopping cart, or from your local distributor.

12. Mechanical Details

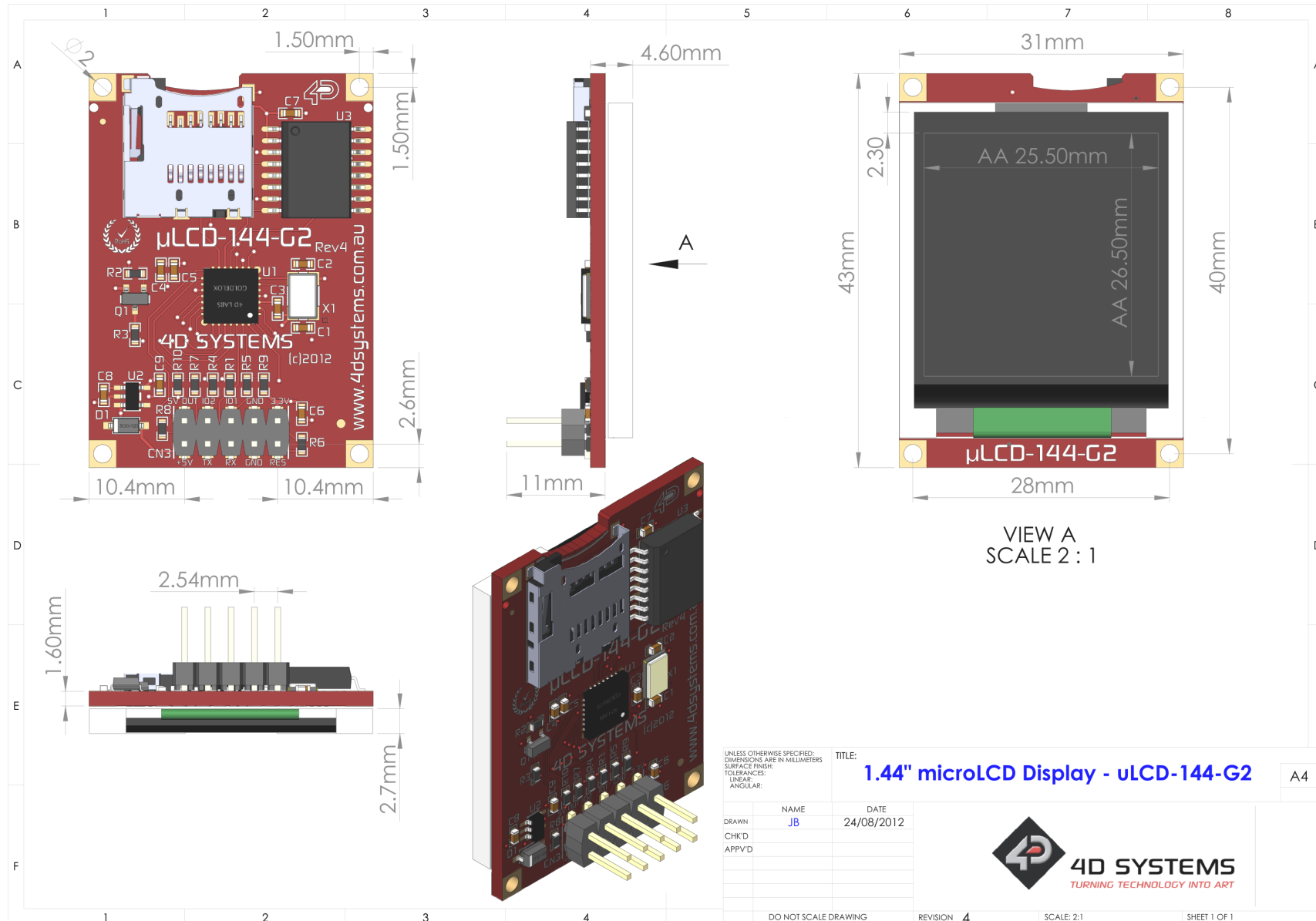

13. Schematic Diagram - REV 5.0

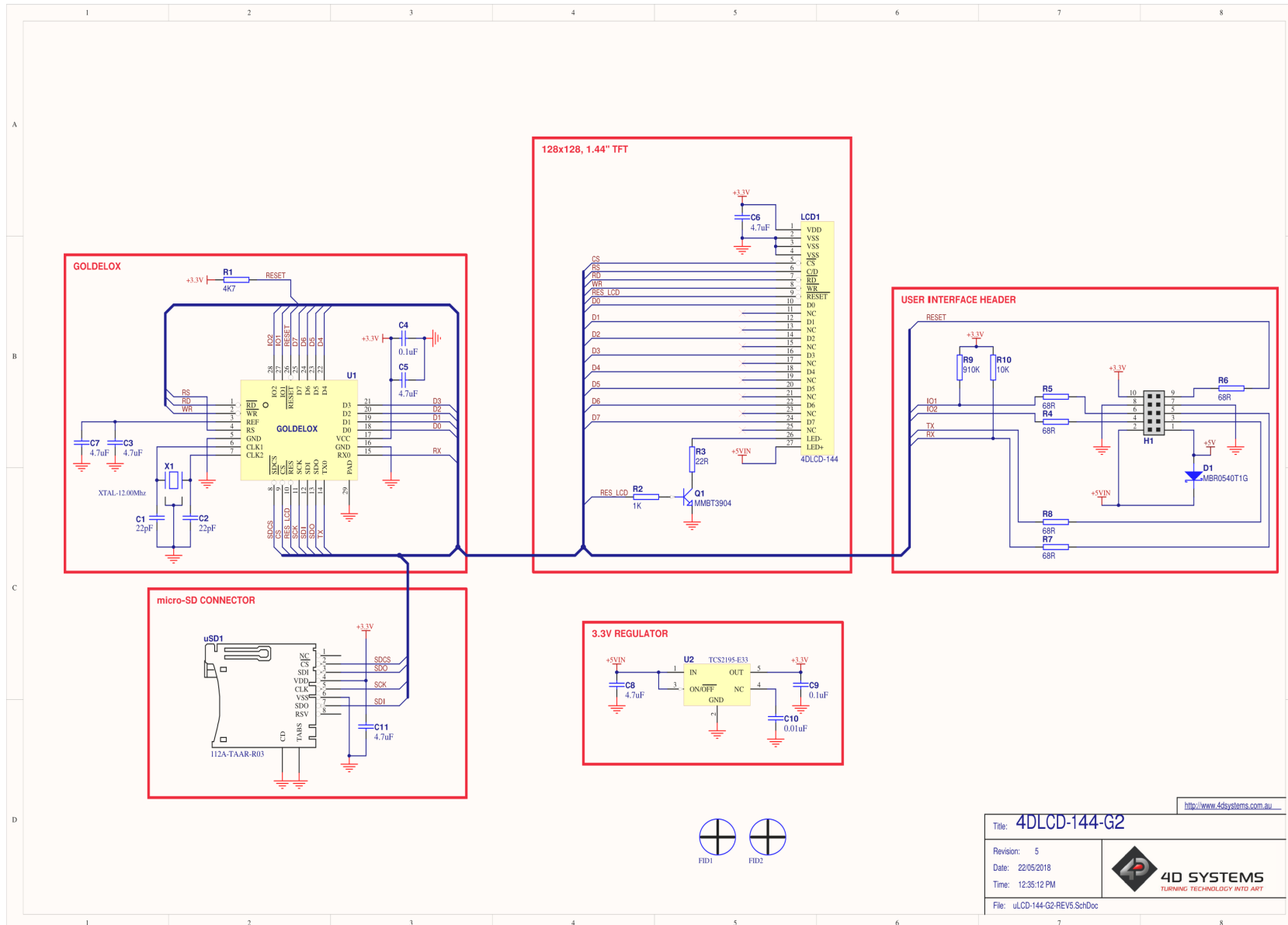

<http://www.4dsystems.com.au>
Title: 4DLCD-144-G2
 Revision: 5
 Date: 22/05/2018
 Time: 12:35:12 PM
 File: uLCD-144-G2-REV5.SchDoc

4D SYSTEMS
TURNING TECHNOLOGY INTO ART

14. Specifications

Absolute Maximum Ratings

Operating ambient temperature	-20°C to +70°C
Storage temperature	-30°C to +80°C
Voltage on any digital input pin with respect to GND	-0.3V to 6.0V
Voltage on SWITCH pin with respect to GND	-0.3V to 6.0V
Voltage on VCC with respect to GND	-0.3V to 6.0V
Maximum current out of GND pin	300mA
Maximum current into VCC pin	250mA
Maximum output current sunk/sourced by any pin	4mA
Total power dissipation	1.0W

Note

Stresses above those listed here may cause permanent damage to the device. This is a stress rating only and functional operation of the device at those or any other conditions above those indicated in the recommended operation listings of this specification is not implied. Exposure to maximum rating conditions for extended periods may affect device reliability.

Recommended Operating Conditions

Parameter	Conditions	Min	Typ	Max	Units
Supply Voltage (VCC)		4.0	5.0	5.5	V
Operating Temperature		-10	--	+60	°C
Input Low Voltage (VIL)	RX Pin	GND	--	0.8	V
Input High Voltage (VIH)	RX Pin	2.0	3.3	5.0	V
Reset Pulse	External Open Collector	2.0	--	--	µs
Operational Delay	Power-Up or External Reset until the module has been able to communicate or until the application has started	--	3000	--	ms

Global Characteristics Based on Operating Conditions

Parameter	Conditions	Min	Typ	Max	Units
Supply Current (ICC)	VCC = 5.0V, very dependent on operating conditions, uSD usage, screen display colour (ie White)	25	40	70	mA
Low Power Current (ICC)	VCC = 5.0V, Contrast = 0	300	500	--	µA
Output Low Voltage (VOL)	TX, IO1, IO2, IOL = 3.4mA	--	--	0.4	V
Output High Voltage (VOH)	TX, IO1, IO2, IOL = -2.0mA	2.4	--	3.3	V
A/D Converter Resolution	IO1 Pin	--	8	10	bits
Capacitive Loading	All pins	--	--	50	pF
Flash Memory Endurance	PmmC/4DGL Programming	--	1000	--	E/W

OPTICAL CHARACTERISTICS

Parameter	Conditions	Min	Typ	Max	Units
Contrast Ratio (Centre point)	Back-light On	300	450	--	--
Luminance of white (Centre point)		160	200	230	cd/m ²
White Uniformity		80	--	--	%
Response Time Rising + Falling (Tr + Tf)		--	--	240	ms
Viewing Angle	Vertical above Centre (Contrast Ratio >=10)		30		Degrees
	Vertical below Centre (Contrast Ratio >=10)		30		Degrees
	Horizontal Left of Centre (Contrast Ratio >=10)		30		Degrees
	Horizontal Right of Centre (Contrast Ratio >=10)		30		Degrees

Ordering Information

Order Code: uLCD-144G2

Package: 65mm x 50mm x 30mm

Packaging: Module sealed in antistatic foam padded 4D Systems Box

15. Revision History

Hardware Revision

Revision Number	Date	Description
4.1	24/18/2012	Initial Public Release Version
5.0	22/05/2018	<ul style="list-style-type: none"> - Changing the 3.3V Regulator - Component changed from 0603 to 0402 - Crystal has been changed

Datasheet Revision

Revision Number	Date	Description
1.4	04/05/2017	Initial Public Release Version
1.5	06/03/2019	Cosmetic changes to uLCD Datasheet
1.6	06/01/2023	Modified datasheet for web-based documentation