



RA12

13.56 MHz Multi-standard RFID Reader IC

REV 2.0

Features Summary

Highlight Features

Special Functions

- Low Power Card Detection
- External RF Field Detection

Supported Protocols

- ISO14443A/B, all bit rates
 - 106, 212, 424, 848 kbps
- ISO15693, all modes
 - Downlink: 1 of 4, 1 of 256
 - Uplink: 6.6,13,26, and 53 kbps with 1 subcarrier
 - Uplink: 6.6,13, and 26 kbps with 2 subcarriers
- NFC tag type 1,2,3,4A,4B,5

Transmitter

- Proximity operation distance up to 10 cm (based in 5 x 3 cm² antenna and 4.5 x 4.5 cm² tag type 5)
- Modulation index adjustable by software
- Output current up to 250mA at 5.0V T_VDD
- Output impedance 3 Ohms at 5.0 V T_VDD
- Arbitrary modulation by an external signal
- Wide operating voltage from 2.7 to 5.5 V
- On-chip framing coder for supported standards

Receiver

- Rx Sensitivity down to 1.42 mVp
- On-chip framing decoder for supported standards
- Rx automatic gain control (AGC)

Interface and peripheral

- Serial peripheral interface (SPI) up to 10 Mbps
- 64-byte send and receive FIFO buffer
- 72-byte addressing user-configurable registers
- Interrupt (IRQ) pin
- Programmable timer
- Low jitter on-chip oscillator buffer
- Ultra low power on-chip 3.3V regulator

Operating conditions

- Operating temperature: -40 °C to 85 °C
- Operating voltage:
 - Receiver A_VDD: 2.7 to 3.6 V
 - Transmitter T_VDD: 2.7 to 5.5 V
 - Digital I/O IO_VDD: 2.7 to 5.5 V
- Power saving mode:
 - Hard Power Down: 0.6uA
 - Soft Power Down: 4.8uA
 - Standby: 1.0mA
 - Card Detection – Sleep: 4.8uA

Applications

- Secure Access Control/Door Lock
- Toy
- Handheld RFID reader
- Contactless payment system

Package

- Small QFN 4x4mm 24-pin with heat sink pad
- Tested Die-on-wafer



Revision History

Revision	Date	Description	Change / Update / Comment
1.0	17 Jan 2020	1 st Release	Official release for RA12 Datsheet
2.0	3 Sep 2021	- Update New template - Updated information	- Update new template - Update ordering information - Update following to Datasheet revision 1.3



Ordering information

Part No.	Description	Package	Marking	Part Status
P002HSRA12QFN4-02	RA12, 13.56MHz RFID Reader IC, ISO14443A/B and ISO15693 Protocol support, IC, T&R	QFN 4x4 mm 24-pin	RA12x MMYYYY	Active
P002HSRA12DOWT-01	RA12, 13.56MHz RFID Reader IC, ISO14443A/B and ISO15693 Protocol support, Die on wafer, Tested , wafer ring 266 mm, thickness 8 mils	DOW	N/A	Active

The information herein is for product information purpose. While the contents in this publication has been carefully checked; no responsibility, however, is assumed for inaccuracies. Silicon Craft Technology PLC. reserves the right to make changes to the products contained in this publication in order to improve design, performance or reliability.



General Description

The RA12 is a single-chip reader ASIC for 13.56-MHz RFID/contactless standard protocols. The RA12 supports all major global secured baseband ISO standards, including ISO14443 Type A, Type B, Crypto_M cards, and Smart label ISO15693. The RA12 provides a hi-speed SPI controller/host interface with a built-in 64-byte FIFO for smooth data transfer. Furthermore, the embedded codec can handle all bit-level coding/decoding, encrypting/decrypting, and frame-level arrangement for transmission and reception. The chip is well suitable for mobile devices due to its low power consumption and low operating voltage from 2.7-3.6 V. The ultra low power on-chip 3.3 V regulator is available to stabilize the chip's supply voltage. It can also supply the regulated voltage to the external companion microcontroller with a supply current up to 150 mA.

The RA12 receiver circuit incorporates a full AGC loop allowing a wide dynamic range of RF input signal levels. The chip's excellent sensitivity performance enables the detection of the input signals with amplitudes as low as 1.42 mVp without distorting the data integrity. The receiver filters can be selected either to a predefined band in accordance with the generic required standard setup or to an arbitrarily defined combination, which gives the flexibility to cope with various antenna variations. The baseband circuits permit the inbound/outbound configuration to cover multiple forms of customized protocols, incoming to the chip and outgoing to the external RF circuitry in the application specific-design system.

The transmitter can operate in a wide range of operating supply voltages to serve various applications, e.g., 5 V for base stations or desktop readers and 3.3 V for handheld devices. The transmission controller is entirely used to support all operation status and requests, including FIFO status full/high/low and complete Transmission flag. The transmitter drivers support a wide range of power supply voltages from 2.7 to 5.5 V. A high drive current up to 250 mA is guaranteed for demanding item-level mid-range reader designs. The dual high-powered transmitters can be flexibly configured in various configurations, e.g., differential driving, single-ended driving, and a mode to drive an external class-E amplifier for improving the drive strength in the gate antenna setup.

The RA12 contains various power-saving modes: hard power down, soft power down, standby, and low-power card detection. The low-power card detection mode allows the chip not to operate at full power continuously. The chip periodically senses the external card. If an external card is detected, an interrupt signal will be sent to MCU to wake up the system.

To facilitate operation of the companion microcontroller, the RA12 is fully equipped with on-chip peripheral support devices such as an RF-trig timer, a host interrupt generator, and a clock divider. The RA12 is offered in a QFN package with excellent heat transfer when mounting on PCB.



Block diagram and typical configuration

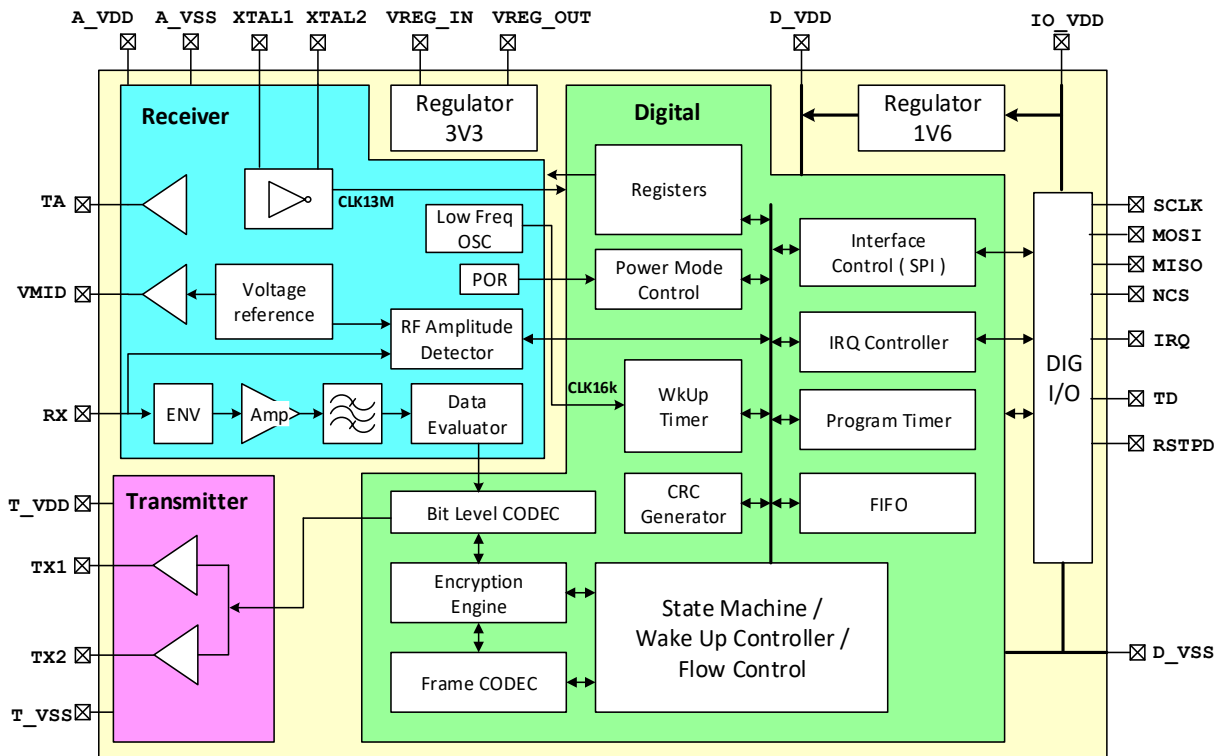

Figure 1 Functional block diagram

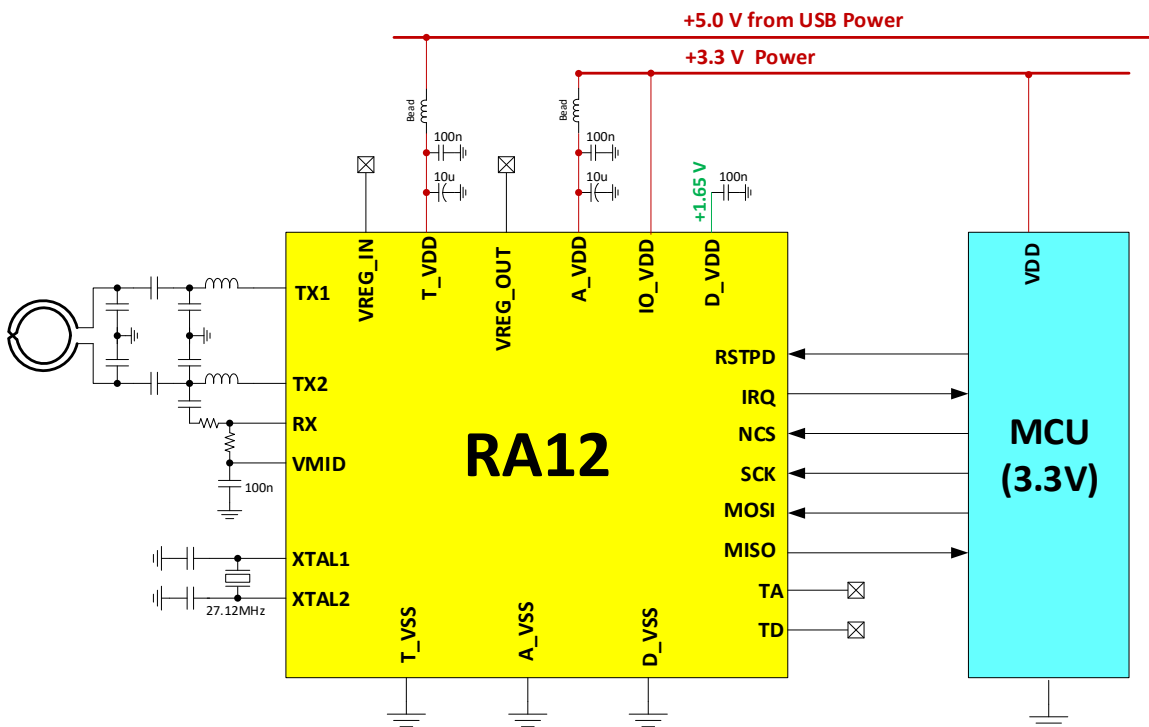

Figure 2 Typical operating circuit for external power supply (not apply on-chip 3.3V regulator)



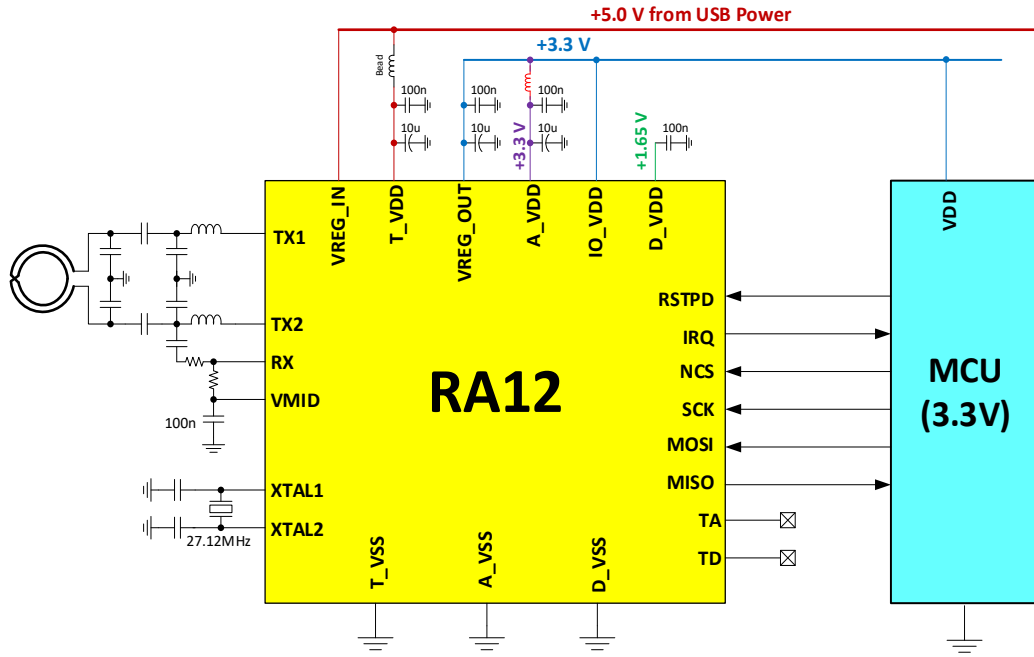

Figure 3 Typical configuration employing on-chip regulator for MCU with 3.3V I/O

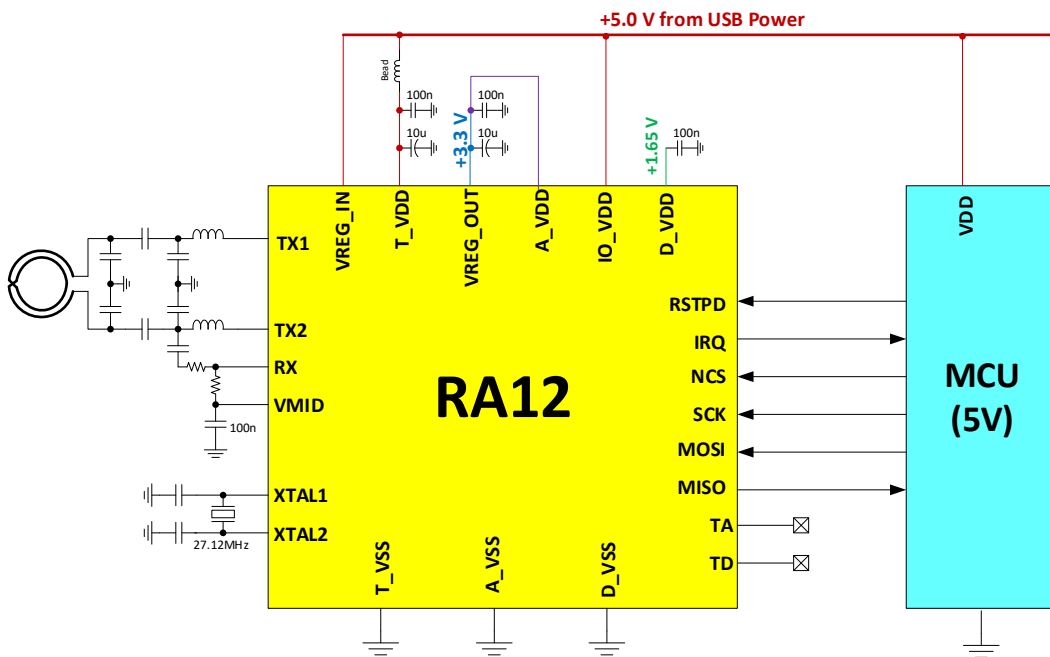

Figure 4 Typical configuration employing on-chip regulator for MCU with 5.0V I/O



Pin configuration

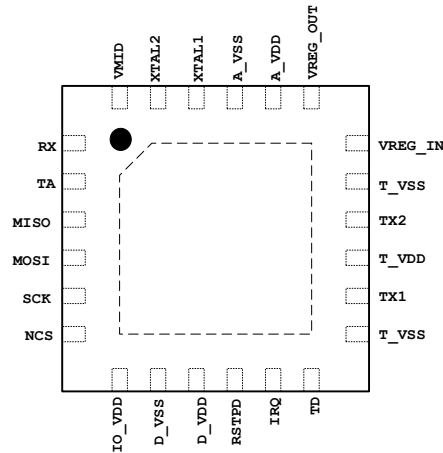

Figure 5 Pin arrangement (top view)

Table 1 Pin function for QFN 4x4 mm package

Pin	Symbol	Type	Description
1	RX	Analog Input	Receiver Input
2	TA	Analog Output	Analog Test Pin
3	MISO	Digital Output	SPI : Master In Slave Out
4	MOSI	Digital Input	SPI : Master Out Slave In
5	SCK	Digital Input	SPI : Clock Input
6	NCS	Digital Input	SPI : Chip Select (Active Low)
7	IO_VDD	Power	Digital I/O Power Supply
8	D_VSS	Power	Digital and Digital I/O Ground
9	D_VDD	Power	Digital Core Power Supply (need external decoupling capacitor 100 nF)
10	RSTPD	Digital Input	Master Reset (Active High)
11	IRQ	Digital Output	Interrupt Request Output
12	TD	Digital I/O	Digital Test Pin
13	T_VSS	Power	Transmitter Ground
14	TX1	Out	Transmitter Output #1
15	T_VDD	Power	Transmitter Power Supply
16	TX2	Out	Transmitter Output #2
17	T_VSS	Power	Transmitter Ground
18	VREG_IN	Power	On-Chip Regulator Input (5 V)
19	VREG_OUT	Power	On-Chip Regulator Output (3.3 V)
20	A_VDD	Power	Analog Power Supply (3.3 V)
21	A_VSS	Power	Analog Ground
22	XTAL1	Analog Input	Crystal Oscillator Input
23	XTAL2	Analog Output	Crystal Oscillator Output
24	VMID	Analog Output	Mid Rail Reference Voltage



Electrical specification

Table 2 Operating conditions

Parameter	Description	Min	Typ	Max	Unit	Conditions
A_VDD	Analog power supply voltage	2.7	3.3	3.6	V	
IO_VDD	Digital I/O power supply voltage	2.7	3.3	5.5	V	
D_VDD	Digital core supply voltage	1.54	1.65	2.20	V	Regulated from internal
T_VDD	Transmitter power supply voltage	2.7	5	5.5	V	
ESD	Electrostatic discharge tolerance		1.5		kV	HBM model
VPOR	Reset trigger voltage	2.30	2.40	2.64	V	IO_VDD and A_VDD



Table 3 Power consumption

Parameter	Description	Min	Typ	Max	Unit	Conditions
I_A_VDD	Analog power supply current A_VDD = 3.3 V		5.5	6.7	mA	Active state (receiver on) ⁽¹⁾
			0.8	1.0	mA	Idle state (receiver off) ⁽¹⁾
				0.2	uA	Hard Power Down (pin RSTPD = '1')
			1.7	2.4	uA	Soft Power Down (PowerDown bit = '1'), 25 °C
				2.5	uA	Soft Power Down (PowerDown bit = '1'), -40 °C to 85 °C
			0.7	0.9	mA	Standby (Standby bit = '1') ⁽¹⁾
			1.7	2.4	uA	Wake Up Card Detection mode (WkUpCD bit = '1') – “ Sleep ”
			3.0	3.3	mA	Wake Up Card Detection mode (WkUpCD bit = '1') – “ Detect ” ⁽¹⁾
I_IO_VDD	Digital I/O power supply current (also include digital core current) IO_VDD = 3.3 V		1.0	1.2	mA	Active state (CODEC on)
			0.9	1.1	mA	Idle state (CODEC off)
				0.2	uA	Hard Power Down (pin RSTPD = '1')
			3.0	4.2	uA	Soft Power Down (PowerDown bit = '1'), 25 °C
				9.3	uA	Soft Power Down (PowerDown bit = '1'), -40 °C to 85 °C
			0.3	0.5	mA	Standby (Standby bit = '1')
			3.0	4.2	uA	Wake Up Card Detection mode (WkUpCD bit = '1') – “ Sleep ”
			0.9	1.1	mA	Wake Up Card Detection mode (WkUpCD bit = '1') – “ Detect ”
Itotal	Total power supply current I_IO_VDD + I_A_VDD + I_T_VDD IO_VDD = A_VDD = T_VDD = 3.3 V, I_TX = 100 mA Not apply on-chip 3.3 V regulator, VREG_IN and VREG_OUT are not connected		6.5	7.8	mA	Active state (receiver on, transmitter off) ⁽¹⁾
			1.7	2.1	mA	Idle state (receiver off, transmitter off) ⁽¹⁾
				0.6	uA	Hard Power Down (pin RSTPD = '1')
			4.8	6.8	uA	Soft Power Down (PowerDown bit = '1'), 25 °C
				12	uA	Soft Power Down (PowerDown bit = '1'), -40 °C to 85 °C
			1.0	1.4	mA	Standby (Standby bit = '1') ⁽¹⁾
			14.2		uA	Average at Wake Up Card Detection mode at TwkUp = 500 mS, transmitter on periodically (calculated) ^{(1) (2)}
			10		uA	Average at Wake Up Card Detection mode at TwkUp = 1000 mS, transmitter on periodically (calculated) ^{(1) (2)}

(1) Current value is also depended on the characteristic of external 27.12 MHz quartz crystal.

(2) Average power in Wake Up Card Detection mode depend on duty cycle between “**Sleep**” and “**Detect**” period.

Table 4 Transmitter characteristic

Parameter	Description	Min	Typ	Max	Unit	Conditions
I_TX	Transmitter current, continuous wave			250	mA	T_VDD = 5 V, 25 °C, average current
R _{outP} , R _{outN}	Equivalent Tx output resistance (GsCfgCW = 0x3F)		3	5	Ohm	T_VDD = 5 V, 25 °C
I_T_VDD,static	Transmitter static power supply current		7		mA	Pin TX1 and TX2 are unconnected RF1En = '1', RF2En = '1' T_VDD = 5 V
M	Adjustable modulation index	0		60	%	T_VDD = 5 V, 100ASK = '0'
				100	%	T_VDD = 5 V, 100ASK = '1'

Table 5 Receiver characteristic

Parameter	Description	Min	Typ	Max	Unit	Conditions
VSEN	Receiver input sensitivity		1.42		mVp	A_VDD = 3.3 V, AGCEn = '1', Gain_ST3 = '000b'
PSRR	Power supply rejection ratio		40		dB	A_VDD = 3.3 V + 0.2*sin(1 MHz)
VRx	Rx input voltage range	0.0		3.3	V	A_VDD = 3.3 V, BypassEnv = '0'
		0.5		2.8	V	A_VDD = 3.3 V, BypassEnv = '1'
VCar,min	Minimum carrier for envelope detector		0.25		Vp	
VVMID	VMID voltage	1.63	1.65	1.67	V	A_VDD = 3.3 V
ZVMID	VMID output impedance @13.56 MHz			0.5	ohm	CL = 100 nF, A_VDD = 3.3 V
Gain	Gain (measured from Rx to the output of the internal last amplifier)	12			dB	Gain = '00b', Gain_ST3 = '000b'
				48	dB	Gain = '11b', Gain_ST3 = '000b'
				69	dB	Gain = '11b', Gain_ST3 = '111b'
Gstep	Gain step		3		dB	AGCEn = '1'
			12		dB	AGCEn = '0' Defined by Gain (0-0x19.[1:0])
FD,min	Minimum RF amplitude at RX pin for external RF field detection.		10		mVp	RF input at RX pin is in phase with internal clock. When the phase is different this value will be more.
CD,min	Minimum RF amplitude changing at RX pin for card detection.		10		mVp	



Table 6 Regulator characteristics

Parameter	Description	Min	Typ	Max	Unit	Conditions
VREG_IN	Regulator input voltage	3.6	5	5.5	V	
VREG_OUT	Regulator output voltage	3.25	3.3	3.35	V	I _{out} = 10 mA, 25 °C
IOUT	Output regulator current			150	mA	
$\Delta V_{out_{LineReg}}$	Line regulation (ΔV_{out})		33	50	mV/V	I _{out} = 0 mA, 3.6 V < VREG_IN < 5.5 V
$\Delta V_{out_{LoadReg}}$	Load regulation (ΔV_{out})		1		mV/mA	VREG_IN = 5 V, 0 < I _{out} < 150 mA
IREGq	Regulator quiescent current		2		uA	No load, VREG_IN = 5 V, 25 °C
			100		uA	I _{out} = 100 mA, VREG_IN = 5 V, 25 °C

