

**Table of Contents-**

1.	GENERAL DESCRIPTION .....	5
2.	FEATURES .....	5
3.	ORDER INFORMATION .....	5
4.	BALL ASSIGNMENT .....	6
4.1	Single-Die-Package (SDP) WFBGA 200 Ball Assignment .....	6
4.2	Dual-Die-Package (DDP) WFBGA 200 Ball Assignment .....	7
5.	BALL CONFIGURATION .....	8
5.1	Ball Description .....	8
5.2	Addressing Table .....	9
6.	BLOCK DIAGRAM .....	10
6.1	Block diagram of single chip .....	10
6.2	Block diagram of Dual-Die-Package (DDP) .....	11
7.	FUNCTIONAL DESCRIPTION .....	12
7.1	Simplified LPDDR4X State Diagram .....	12
7.1.1	Simplified Bus Interface State Diagram .....	13
7.2	Power-up, Initialization, and Power-Off Procedure .....	15
7.2.1	Voltage Ramp and Device Initialization .....	15
7.2.2	Reset Initialization with Stable Power .....	17
7.2.3	Power-off Sequence .....	17
7.2.4	Uncontrolled Power-Off Sequence .....	18
7.3	Mode Register Definition .....	19
7.3.1	MR0 Register Information (MA[5:0] = 00H) .....	20
7.3.2	MR1 Register Information (MA[5:0] = 01H) .....	21
7.3.3	MR2 Register Information (MA[5:0] = 02H) .....	23
7.3.4	MR3 Register Information (MA[5:0] = 03H) .....	24
7.3.5	MR4 Register Information (MA[5:0] = 04H) .....	25
7.3.6	MR5 Register Information (MA[5:0] = 05H) .....	26
7.3.7	MR6 Register Information (MA[5:0] = 06H) .....	26
7.3.8	MR7 Register Information (MA[5:0] = 07H) .....	26
7.3.9	MR8 Register Information (MA[5:0] = 08H) .....	26
7.3.10	MR9 Register Information (MA[5:0] = 09H) .....	26
7.3.11	MR10 Register Information (MA[5:0] = 0AH) .....	26
7.3.12	MR11 Register Information (MA[5:0] = 0BH) .....	27
7.3.13	MR12 Register Information (MA[5:0] = 0CH) .....	27
7.3.14	MR13 Register Information (MA[5:0] = 0DH) .....	29
7.3.15	MR14 Register Information (MA[5:0] = 0EH) .....	30
7.3.16	MR15 Register Information (MA[5:0] = 0FH) .....	32
7.3.17	MR16 Register Information (MA[5:0] = 10H) .....	33
7.3.18	MR17 Register Information (MA[5:0] = 11H) .....	33
7.3.19	MR18 Register Information (MA[5:0] = 12H) .....	34
7.3.20	MR19 Register Information (MA[5:0] = 13H) .....	34
7.3.21	MR20 Register Information (MA[5:0] = 14 H) .....	34
7.3.22	MR21 Register (Reserved) (MA[5:0] = 15H) .....	34
7.3.23	MR22 Register Information (MA[5:0] = 16H) .....	35
7.3.24	MR23 Register Information (MA[5:0] = 17H) .....	36
7.3.25	MR24 Register Information (MA[5:0] = 18H) .....	36
7.3.26	MR25 Register Information (MA[5:0] = 19H) .....	37
7.3.27	MR26~29 (Reserved) (MA[5:0] = 1AH-1DH) .....	37



7.3.28	MR30 Register Information (MA[5:0] = 1E <sub>H</sub> ) .....	37
7.3.29	MR31 (Reserved) (MA[5:0] = 1F <sub>H</sub> ) .....	37
7.3.30	MR32 Register Information (MA[5:0] = 20 <sub>H</sub> ) .....	37
7.3.31	MR33-38 (Reserved) (MA[5:0] = 21 <sub>H</sub> -26 <sub>H</sub> ) .....	37
7.3.32	MR39 Register Information (MA[5:0] = 27 <sub>H</sub> ) .....	38
7.3.33	MR40 Register Information (MA[5:0] = 28 <sub>H</sub> ) .....	38
7.4	Command Definitions and Timing Diagrams .....	39
7.4.1	Activate Command .....	39
7.4.1.1	8-Bank Device Operation .....	39
7.4.2	Core Timing .....	40
7.4.3	Read and Write Access Operations .....	41
7.4.4	Read Preamble and Postamble .....	41
7.4.5	Burst Read Operation .....	42
7.4.6	Read Timing .....	46
7.4.7	tLZ(DQS), tLZ(DQ), tHZ(DQS), tHZ(DQ) Calculation .....	46
7.4.7.1	tLZ(DQS) and tHZ(DQS) Calculation for ATE (Automatic Test Equipment) .....	47
7.4.7.2	tLZ(DQ) and tHZ(DQ) Calculation for ATE (Automatic Test Equipment) .....	49
7.4.7.3	tRPRE Calculation for ATE (Automatic Test Equipment) .....	51
7.4.7.4	tRPST Calculation for ATE (Automatic Test Equipment) .....	52
7.4.8	tDQSCK Timing Table .....	53
7.4.8.1	CK to DQS Rank to Rank variation .....	53
7.4.9	Write Preamble and Postamble .....	54
7.4.10	Burst Write Operation .....	55
7.4.11	Write Timing .....	58
7.4.11.1	tWPRE Calculation for ATE (Automatic Test Equipment) .....	59
7.4.11.2	tWPST Calculation for ATE (Automatic Test Equipment) .....	60
7.4.12	Read and Write Latencies .....	61
7.4.13	Write and Masked Write operation DQS controls (WDQS Control) .....	61
7.4.13.1	WDQS Control Mode 1 - Read Based Control .....	62
7.4.13.2	WDQS Control Mode 2 - WDQS_on/off .....	62
7.4.14	Postamble and Preamble merging behavior .....	67
7.4.14.1	Read to Read Operation .....	67
7.4.14.2	Write to Write Operation .....	80
7.4.15	Masked Write Operation .....	90
7.4.15.1	Masked Write Timing constraints for BL16 .....	92
7.4.16	LPDDR4X Data Mask (DM) and Data Bus Inversion (DBI <sub>dc</sub> ) Function .....	94
7.4.17	Precharge Operation .....	97
7.4.17.1	Burst Read Operation Followed by a Precharge .....	98
7.4.17.2	Burst Write Operation Followed by a Precharge .....	99
7.4.17.3	Auto-Precharge Operation .....	99
7.4.17.4	Burst Read with Auto-Precharge .....	100
7.4.17.5	Burst Write with Auto-Precharge .....	101
7.4.18	Auto-Precharge Operation .....	102
7.4.18.1	Delay time from Write to Read with Auto-Precharge .....	103
7.4.19	Refresh command .....	107
7.4.19.1	Burst Read operation followed by Per Bank Refresh .....	113
7.4.20	Refresh Requirement .....	114
7.4.21	Self Refresh Operation .....	115
7.4.21.1	Self Refresh Entry and Exit .....	115
7.4.21.2	Power Down Entry and Exit during Self Refresh .....	116
7.4.21.3	Command input Timing after Power Down Exit .....	117
7.4.21.4	AC Timing Table .....	118
7.4.22	MRR, MRW, MPC Command during tXSR, tRFC .....	119
7.4.23	MODE REGISTER READ (MRR) .....	120
7.4.23.1	MRR after Read and Write command .....	122
7.4.23.2	MRR after Power-Down Exit .....	124



7.4.24	Mode Register Write (MRW) Operation .....	125
7.4.24.1	Mode Register Write .....	125
7.4.25	VREF Current Generator (VRCG) .....	127
7.4.26	CA VREF Training .....	128
7.4.27	DQ VREF Training .....	133
7.4.28	Command Bus Training .....	138
7.4.28.1	Training Sequence for single-rank systems .....	139
7.4.28.2	Training Sequence for multi-rank systems .....	139
7.4.28.3	Relation between CA input pin DQ output pin .....	140
7.4.28.4	Timing Diagram .....	140
7.4.28.5	Command Bus Training AC Timing Table .....	145
7.4.29	Frequency Set Point .....	146
7.4.29.1	Frequency set point update Timing .....	147
7.4.30	Mode Register Write-WR Leveling Mode .....	151
7.4.30.1	Write Leveling Procedure .....	151
7.4.30.2	Input Clock Frequency Stop and Change .....	153
7.4.30.3	Write Leveling Setup and Hold Time .....	154
7.4.31	RD DQ Calibration .....	155
7.4.31.1	RD DQ Calibration Training Procedure .....	155
7.4.31.2	DQ Read Training Example .....	158
7.4.31.3	MPC of Read DQ Calibration after Power-Down Exit .....	159
7.4.32	DQS-DQ Training .....	160
7.4.32.1	FIFO Pointer Reset and Synchronism .....	161
7.4.33	DQS Interval Oscillator .....	166
7.4.33.1	Interval Oscillator matching error .....	168
7.4.33.2	DQS Interval Oscillator Readout Timing .....	169
7.4.34	READ Preamble Training .....	171
7.4.35	Multi-Purpose Command (MPC) .....	172
7.4.36	Thermal Offset .....	176
7.4.37	Temperature Sensor .....	176
7.4.38	ZQ Calibration .....	178
7.4.38.1	ZQCal Reset .....	178
7.4.38.2	ZQ External Resistor, Tolerance, and Capacitive Loading .....	179
7.4.39	Pull Up/Pull Down Driver Characteristics and Calibration .....	179
7.4.40	On Die Termination for Command/Address Bus .....	180
7.4.40.1	ODT Mode Register and ODT State Table .....	180
7.4.40.2	ODT Mode Register and ODT Characteristics .....	181
7.4.40.3	ODT for Command/Address update time .....	183
7.4.41	On-Die Termination .....	184
7.4.41.1	ODT Mode Register .....	184
7.4.41.2	Asynchronous ODT .....	184
7.4.41.3	ODT during Write Leveling .....	186
7.4.42	On Die Termination for DQ, DQS and DMI .....	187
7.4.43	Output Driver and Termination Register Temperature and Voltage Sensitivity .....	189
7.4.44	Power-Down Mode .....	190
7.4.44.1	Power-Down Entry and Exit .....	190
7.4.45	Input Clock Stop and Frequency Change .....	197
7.4.46	Truth Tables .....	199
7.4.47	TRR Mode - Target Row Refresh .....	201
7.4.47.1	TRR Mode Operation .....	201
7.4.48	Post Package Repair (PPR) .....	203
7.4.48.1	Fail Row Address Repair .....	203
8.	ELECTRICAL CHARACTERISTIC .....	205
8.1	Absolute Maximum DC Ratings .....	205
8.2	AC & DC Operating Conditions .....	205
8.2.1	Recommended DC Operating Conditions .....	205
8.2.2	Input Leakage Current .....	205



8.2.3	Input/Output Leakage Current .....	205
8.2.4	Operating Temperature Range .....	206
8.3	AC and DC Input/Output Measurement levels .....	206
8.3.1	1.1 V High speed LVCMOS (HS_LLVC MOS) .....	206
8.3.1.1	Standard specifications .....	206
8.3.1.2	DC electrical characteristics .....	206
8.3.1.2.1	LPDDR4X Input Level for CKE .....	206
8.3.1.2.2	LPDDR4X Input Level for Reset_n and ODT_CA .....	207
8.3.1.3	AC Over/Undershoot .....	207
8.3.1.3.1	LPDDR4X AC Over/Undershoot .....	207
8.3.2	Differential Input Voltage .....	208
8.3.2.1	Differential Input Voltage for CK .....	208
8.3.2.2	Peak voltage calculation method .....	209
8.3.2.3	Single-Ended Input Voltage for Clock .....	210
8.3.2.4	Differential Input Slew Rate Definition for Clock .....	211
8.3.2.5	Differential Input Cross Point Voltage .....	212
8.3.2.6	Differential Input Voltage for DQS .....	213
8.3.2.7	Peak voltage calculation method .....	214
8.3.2.8	Single-Ended Input Voltage for DQS .....	215
8.3.2.9	Differential Input Slew Rate Definition for DQS .....	216
8.3.2.10	Differential Input Cross Point Voltage .....	217
8.3.3	Input level for ODT_CA input .....	218
8.3.4	Single Ended Output Slew Rate .....	218
8.3.5	Differential Output Slew Rate .....	219
8.3.6	Overshoot and Undershoot for LVSTL .....	220
8.3.7	LPDDR4X Driver Output Timing Reference load .....	221
8.3.8	LVSTL (Low Voltage Swing Terminated Logic) IO System .....	221
8.4	Input/Output Capacitance .....	223
8.5	IDD Specification Parameters and Test Conditions .....	224
8.5.1	IDD Measurement Conditions .....	224
8.5.2	IDD Specifications .....	230
8.6	Electrical Characteristics and AC Timing .....	236
8.6.1	Clock Specification .....	236
8.6.1.1	Definition for tCK(avg) and nCK .....	236
8.6.1.2	Definition for tCK(abs) .....	236
8.6.1.3	Definition for tCH(avg) and tCL(avg) .....	237
8.6.1.4	Definition for tCH(abs) and tCL(abs) .....	237
8.6.1.5	Definition for tJIT(per) .....	237
8.6.1.6	Definition for tJIT(cc) .....	237
8.6.2	Clock AC Timing .....	238
8.6.3	Temperature Derating for AC timing .....	238
8.6.4	CA Rx voltage and timing .....	239
8.6.5	DRAM Data Timing .....	242
8.6.6	DQ Rx voltage and timing .....	244
9.	PACKAGE DIMENSIONS .....	248
10.	REVISION HISTORY .....	249



## 1. GENERAL DESCRIPTION

This datasheet is covering LPDDR4X device with either one of following configurations.

Single-Die-Package (SDP) 16Mb x 16DQ x 8-banks x 1 channel with 2 Gb (2,147,483,648 bits) density.

Dual-Die-Package (DDP) 16Mb x 16DQ x 8-banks x 2 channels with 4 Gb (4,294,967,296 bits) density.

This LPDDR4X device uses a 2 or 4 clocks architecture on the Command/Address (CA) bus to reduce the number of input pins in the system. The 6-bit CA bus contains command, address, and bank information. Each command uses 1, 2 or 4 clock cycle, during which command information is transferred on the positive edge of the clock. See command truth table for details. See command truth table for details.

## 2. FEATURES

- |  |   |
|--|---|
| <ul style="list-style-type: none"> <li>• VDD1 = 1.7~1.95V</li> <li>• VDD2 = 1.06V~1.17V</li> <li>• VDDQ = 0.57V~0.65V</li> <li>• Data width: x16/x32</li> <li>• Clock rate: up to 2133 MHz</li> <li>• Data rate: up to 4267 Mbps</li> <li>• 8 internal banks for concurrent operation</li> <li>• 16n pre-fetch operation</li> <li>• Interface: LVSTL_11</li> <li>• Burst length: 16, 32, on-the-fly 16 or 32</li> <li>• Burst type: Sequential</li> <li>• Programmable Driver strength</li> <li>• Coded command input in double clock edges</li> <li>• Single data rate architecture on the CA bus</li> <li>• Double data rate architecture on the DQ pins</li> <li>• Differential clock input</li> <li>• Bidirectional differential data strobe</li> <li>• Input clock stop and frequency change</li> <li>• On-die termination (ODT)</li> </ul> | <ul style="list-style-type: none"> <li>• Write leveling support</li> <li>• Programmable Read and Write Latencies (RL/WL)</li> <li>• CA training support</li> <li>• DQ-DQS training</li> <li>• Refresh feature:               <ul style="list-style-type: none"> <li>- Auto Refresh (per bank / all bank)</li> <li>- Partial array self-refresh</li> <li>- Auto temperature compensated self-refresh</li> </ul> </li> <li>• Post Package Repair</li> <li>• Target Row Refresh Mode</li> <li>• Frequency-Set-Points for fast frequency switch</li> <li>• Support write mask and data bus inversion(DBI)</li> <li>• Support Boundary Scan for connectivity test*</li> <li>• Support package:               <ul style="list-style-type: none"> <li>WFBGA 200 Ball (10x14.5mm<sup>2</sup>)</li> </ul> </li> <li>• Operating Temperature Range:               <ul style="list-style-type: none"> <li>-40°C ≤ TCASE ≤ 95°C</li> <li>-40°C ≤ TCASE ≤ 105°C</li> <li>0°C ≤ TCASE ≤ 70°C</li> </ul> </li> </ul> |
|--|---|

\* For further information about Boundary Scan for connectivity test, please contact sales representative.

## 3. ORDER INFORMATION

Part Number	VDD1/VDD2/VDDQ	I/O Width	Type	Others
W66BM6NBUIAFI	1.8V/1.1V/0.6V	16	WFBGA 200 ball (SDP)	LPDDR4X-3200, -40°C~95°C
W66BM6NBUIAGI	1.8V/1.1V/0.6V	16	WFBGA 200 ball (SDP)	LPDDR4X-3733, -40°C~95°C
W66BM6NBUIAHI	1.8V/1.1V/0.6V	16	WFBGA 200 ball (SDP)	LPDDR4X-4267, -40°C~95°C
W66CM2NQUAFI	1.8V/1.1V/0.6V	32	WFBGA 200 ball (DDP)	LPDDR4X-3200, -40°C~95°C
W66CM2NQUAGI	1.8V/1.1V/0.6V	32	WFBGA 200 ball (DDP)	LPDDR4X-3733, -40°C~95°C
W66CM2NQUAHI	1.8V/1.1V/0.6V	32	WFBGA 200 ball (DDP)	LPDDR4X-4267, -40°C~95°C
W66BM6NBUIAFJ	1.8V/1.1V/0.6V	16	WFBGA 200 ball (SDP)	LPDDR4X-3200, -40°C~105°C
W66BM6NBUIAGJ	1.8V/1.1V/0.6V	16	WFBGA 200 ball (SDP)	LPDDR4X-3733, -40°C~105°C
W66BM6NBUIAHJ	1.8V/1.1V/0.6V	16	WFBGA 200 ball (SDP)	LPDDR4X-4267, -40°C~105°C
W66CM2NQUAFJ	1.8V/1.1V/0.6V	32	WFBGA 200 ball (DDP)	LPDDR4X-3200, -40°C~105°C
W66CM2NQUAGJ	1.8V/1.1V/0.6V	32	WFBGA 200 ball (DDP)	LPDDR4X-3733, -40°C~105°C
W66CM2NQUAHJ	1.8V/1.1V/0.6V	32	WFBGA 200 ball (DDP)	LPDDR4X-4267, -40°C~105°C
W66CM2NQUAHC	1.8V/1.1V/0.6V	32	WFBGA 200 ball (DDP)	LPDDR4X-4267, 0°C~70°C

Publication Release Date: Sep. 18, 2019

Revision: A01-003



4. BALL ASSIGNMENT

4.1 Single-Die-Package (SDP) WFBGA 200 Ball Assignment

[Top View]

	1	2	3	4	5	6	7	8	9	10	11	12
A	DNU	DNU	VSS	VDD2	ZQ0			NC	VDD2	VSS	DNU	DNU
B	SEN_A	DQ0_A	VDDQ	DQ7_A	VDDQ			VDDQ	DQ15_A	VDDQ	DQ8_A	DNU
C	VSS	DQ1_A	DMI0_A	DQ6_A	VSS			VSS	DQ14_A	DMI1_A	DQ9_A	VSS
D	VDDQ	VSS	DQS0_L_A	VSS	VDDQ			VDDQ	VSS	DQS1_t_A	VSS	VDDQ
E	VSS	DQ2_A	DQS0_c_A	DQ5_A	VSS			VSS	DQ13_A	DQS1_c_A	DQ10_A	VSS
F	VDD1	DQ3_A	VDDQ	DQ4_A	VDD2			VDD2	DQ12_A	VDDQ	DQ11_A	VDD1
G	VSS	ODT_CA_A	VSS	VDD1	VSS			VSS	VDD1	VSS	NC	VSS
H	VDD2	CA0_A	NC	CS0_A	VDD2			VDD2	CA2_A	CA3_A	CA4_A	VDD2
J	VSS	CA1_A	VSS	CKE0_A	NC			CK_t_A	CK_c_A	VSS	CA5_A	VSS
K	VDD2	VSS	VDD2	VSS	NC			NC	VSS	VDD2	VSS	VDD2
L												
M												
N	VDD2	VSS	VDD2	VSS	NC			NC	VSS	VDD2	VSS	VDD2
P	VSS	NC	VSS	NC	NC			NC	NC	VSS	NC	VSS
R	VDD2	NC	NC	NC	VDD2			VDD2	NC	NC	NC	VDD2
T	VSS	NC	VSS	VDD1	VSS			VSS	VDD1	VSS	RESET_n	VSS
U	VDD1	NC	VDDQ	NC	VDD2			VDD2	NC	VDDQ	NC	VDD1
V	VSS	NC	NC	NC	VSS			VSS	NC	NC	NC	VSS
W	VDDQ	VSS	NC	VSS	VDDQ			VDDQ	VSS	NC	VSS	VDDQ
Y	VSS	NC	NC	NC	VSS			VSS	NC	NC	NC	VSS
AA	DNU	NC	VDDQ	NC	VDDQ			VDDQ	NC	VDDQ	NC	DNU
BB	DNU	DNU	VSS	VDD2	VSS			VSS	VDD2	VSS	DNU	DNU

WFBGA 200 Ball Assignment for SDP



4.2 Dual-Die-Package (DDP) WFBGA 200 Ball Assignment  
[Top View]

	1	2	3	4	5	6	7	8	9	10	11	12
A	DNU	DNU	VSS	VDD2	ZQ0			NC	VDD2	VSS	DNU	DNU
B	SEN_A	DQ0_A	VDDQ	DQ7_A	VDDQ			VDDQ	DQ15_A	VDDQ	DQ8_A	DNU
C	VSS	DQ1_A	DMI0_A	DQ6_A	VSS			VSS	DQ14_A	DMI1_A	DQ9_A	VSS
D	VDDQ	VSS	DQS0_t_A	VSS	VDDQ			VDDQ	VSS	DQS1_t_A	VSS	VDDQ
E	VSS	DQ2_A	DQS0_c_A	DQ5_A	VSS			VSS	DQ13_A	DQS1_c_A	DQ10_A	VSS
F	VDD1	DQ3_A	VDDQ	DQ4_A	VDD2			VDD2	DQ12_A	VDDQ	DQ11_A	VDD1
G	VSS	ODT_CA_A	VSS	VDD1	VSS			VSS	VDD1	VSS	NC	VSS
H	VDD2	CA0_A	NC	CS0_A	VDD2			VDD2	CA2_A	CA3_A	CA4_A	VDD2
J	VSS	CA1_A	VSS	CKE0_A	NC			CK_t_A	CK_c_A	VSS	CA5_A	VSS
K	VDD2	VSS	VDD2	VSS	NC			NC	VSS	VDD2	VSS	VDD2
L												
M												
N	VDD2	VSS	VDD2	VSS	NC			NC	VSS	VDD2	VSS	VDD2
P	VSS	CA1_B	VSS	CKE0_B	NC			CK_t_B	CK_c_B	VSS	CA5_B	VSS
R	VDD2	CA0_B	NC	CS0_B	VDD2			VDD2	CA2_B	CA3_B	CA4_B	VDD2
T	VSS	ODT_CA_B	VSS	VDD1	VSS			VSS	VDD1	VSS	RESET_n	VSS
U	VDD1	DQ3_B	VDDQ	DQ4_B	VDD2			VDD2	DQ12_B	VDDQ	DQ11_B	VDD1
V	VSS	DQ2_B	DQS0_c_B	DQ5_B	VSS			VSS	DQ13_B	DQS1_c_B	DQ10_B	VSS
W	VDDQ	VSS	DQS0_t_B	VSS	VDDQ			VDDQ	VSS	DQS1_t_B	VSS	VDDQ
Y	VSS	DQ1_B	DMI0_B	DQ6_B	VSS			VSS	DQ14_B	DMI1_B	DQ9_B	VSS
AA	DNU	DQ0_B	VDDQ	DQ7_B	VDDQ			VDDQ	DQ15_B	VDDQ	DQ8_B	SEN_B
BB	DNU	DNU	VSS	VDD2	VSS			VSS	VDD2	VSS	DNU	DNU

WFBGA 200 Ball Assignment for DDP





## 5. BALL CONFIGURATION

### 5.1 Ball Description

Name	Type	Description
CK_t_A, CK_c_A, CK_t_B, CK_c_B	Input	<b>Clock:</b> CK_t and CK_c are differential clock inputs. All address, command, and control input signals are sampled on the crossing of the positive edge of CK_t and the negative edge of CK_c. AC timings for CA parameters are referenced to CK. Each channel (A & B) has its own clock pair.
CKE_A, CKE_B	Input	<b>Clock Enable:</b> CKE HIGH activates and CKE LOW deactivates the internal clock circuits, input buffers, and output drivers. Power-saving modes are entered and exited via CKE transitions. Each channel (A & B) has its own CKE signal.
CS_A, CS_B	Input	<b>Chip Select:</b> CS is part of the command code. Each channel (A & B) has its own CS signal.
CA[5:0]_A, CA[5:0]_B	Input	<b>Command/Address Inputs:</b> CA signals provide the Command and Address inputs according to the Command Truth Table. Each channel (A & B) has its own CA signals.
ODT_CA_A, ODT_CA_B	Input	<b>CA ODT Control:</b> The ODT_CA pin is ignored by LPDDR4X devices. ODT-CS/CA/CK function is fully controlled through MR11 and MR22. The ODT_CA pin shall be connected to either VDD2 or VSS.
DQ[15:0]_A, DQ[15:0]_B	I/O	<b>Data Inputs/Output:</b> Bi-directional data bus.
DQS[1:0]_t_A, DQS[1:0]_c_A, DQS[1:0]_t_B, DQS[1:0]_c_B	I/O	<b>Data Strobe:</b> DQS_t and DQS_c are bi-directional differential output clock signals used to strobe data during a READ or WRITE. The Data Strobe is generated by the DRAM for a READ and is edge-aligned with Data. The Data Strobe is generated by the Memory Controller for a WRITE and must arrive prior to Data. Each byte of data has a Data Strobe signal pair. Each channel (A & B) has its own DQS strobes.
DMI[1:0]_A, DMI[1:0]_B	I/O	<b>Data Mask Inversion:</b> DMI is a bi-directional signal which is driven HIGH when the data on the data bus is inverted, or driven LOW when the data is in its normal state. Data Inversion can be disabled via a mode register setting. Each byte of data has a DMI signal. Each channel (A & B) has its own DMI signals. This signal is also used along with the DQ signals to provide write data masking information to the DRAM. The DMI pin function - Data Inversion or Data mask - depends on Mode Register setting.
RESET_n	Input	<b>RESET:</b> When asserted LOW, the RESET_n signal resets all channels of the die. There is one RESET_n pad per die.
VDDQ, VDD1, VDD2	Supply	<b>Power Supplies:</b> Isolated on the die for improved noise immunity.
VSS, VSSQ	Supply	<b>Ground Reference:</b> Power supply ground reference.
ZQ0	Reference	<b>Calibration Reference:</b> Used to calibrate the output drive strength and the termination resistance. The ZQ0 pin shall be connected to VDDQ through a $240\Omega \pm 1\%$ resistor.
SEN	Input	<b>Scan Enable:</b> SEN must be asserted HIGH for enabling boundary scan function. Must be tied to Ground or NC (No Connection) when not in use.
DNU	--	<b>Do Not Use</b>
NC	--	<b>No connect:</b> Not internally connected.

**Note:**

1. "\_A" and "\_B" indicate DRAM channel. "\_A" pads are present in all devices. "\_B" pads are present in dual channel DRAM devices only.





## 5.2 Addressing Table

		128M x 16	128M x 32
Die per package		1	2
Memory Density (per package)		2 Gb	4 Gb
Memory Density (per die)		2 Gb	2 Gb
Memory Density (per channel)		2 Gb	2 Gb
Configuration		16Mb x 16DQ x 8 banks x 1 channel	16Mb x 16DQ x 8 banks x 2 channels
Number of Channels (per die)		1	1
Number of Banks (per channel)		8	8
Array Pre-Fetch (bits, per channel)		256	256
Number of Rows (per channel)		16384	16384
Number of Columns (fetch boundaries)		64	64
Page Size (Bytes)		2048	2048
Bank Address		BA0 – BA2	BA0 – BA2
x16	Row Addresses	R0 – R13	R0 – R13
	Column Addresses	C0 – C9	C0 – C9
Burst Starting Address Boundary		64 bit	64 bit

### Note:

1. The lower two column addresses (C0 - C1) are assumed to be “zero” and are not transmitted on the CA bus.



## 6. BLOCK DIAGRAM

### 6.1 Block diagram of single chip

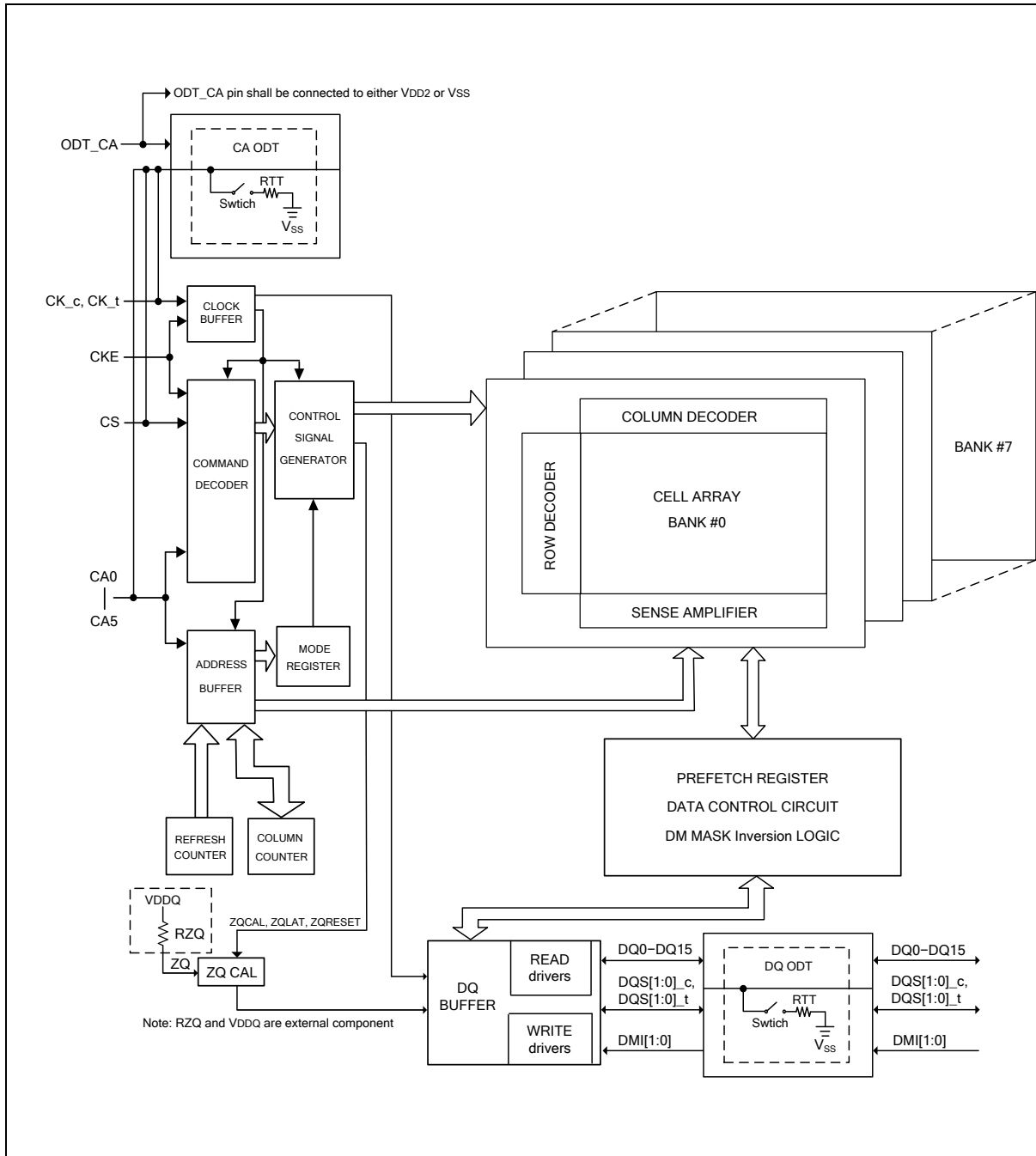

**Note:** This block diagram of single chip not include boundary scan for connectivity test block.



6.2 Block diagram of Dual-Die-Package (DDP)

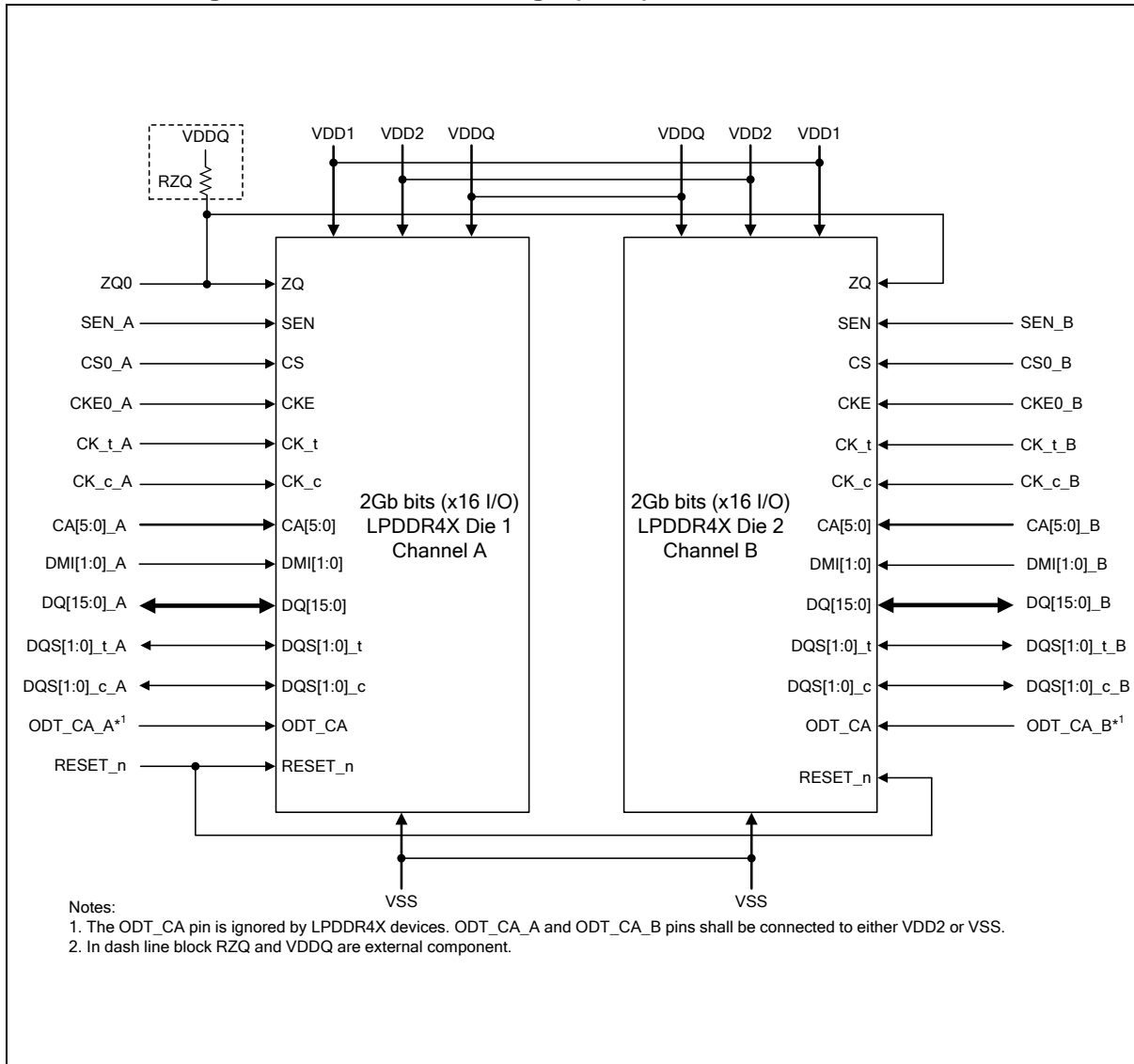



## 7. FUNCTIONAL DESCRIPTION

For this LPDDR4X device, accesses begin with the registration of an Activate command, which is then followed by a Read or Write command. The address and BA bits registered coincident with the Activate command are used to select the row and the Bank to be accessed. The address bits registered coincident with the Read or Write command are used to select the Bank and the starting column location for the burst access.

This device also uses double data rate architecture on the DQ pins to achieve high speed operation. The double data rate architecture is essentially a  $16n$  prefetch architecture with an interface designed to transfer two data bits per DQ every clock cycle at the I/O pins. A single read or write access for the LPDDR4X SDRAM effectively consists of a single  $16n$ -bit wide, one clock cycle data transfer at the internal DRAM core and eight corresponding  $n$ -bit wide, one-half-clock-cycle data transfers at the I/O pins.

Read and write accesses to this LPDDR4X SDRAMs are burst oriented; accesses start at a selected location and continue for a programmed number of locations in a programmed sequence. Prior to normal operation, this LPDDR4X SDRAM must be initialized. The following section provides detailed information covering device initialization, register definition, command description and device operation.

### 7.1 Simplified LPDDR4X State Diagram

LPDDR4X-SDRAM state diagram provides a simplified illustration of allowed state transitions and the related commands to control them. For a complete definition of the device behavior, the information provided by the state diagram should be integrated with the truth tables and timing specification.

The truth tables provide complementary information to the state diagram; they clarify the device behavior and the applied restrictions when considering the actual state of all the banks.

For the command definition, see chapter 7.4 “**Command Definitions and Timing Diagrams**”.



7.1.1 Simplified Bus Interface State Diagram

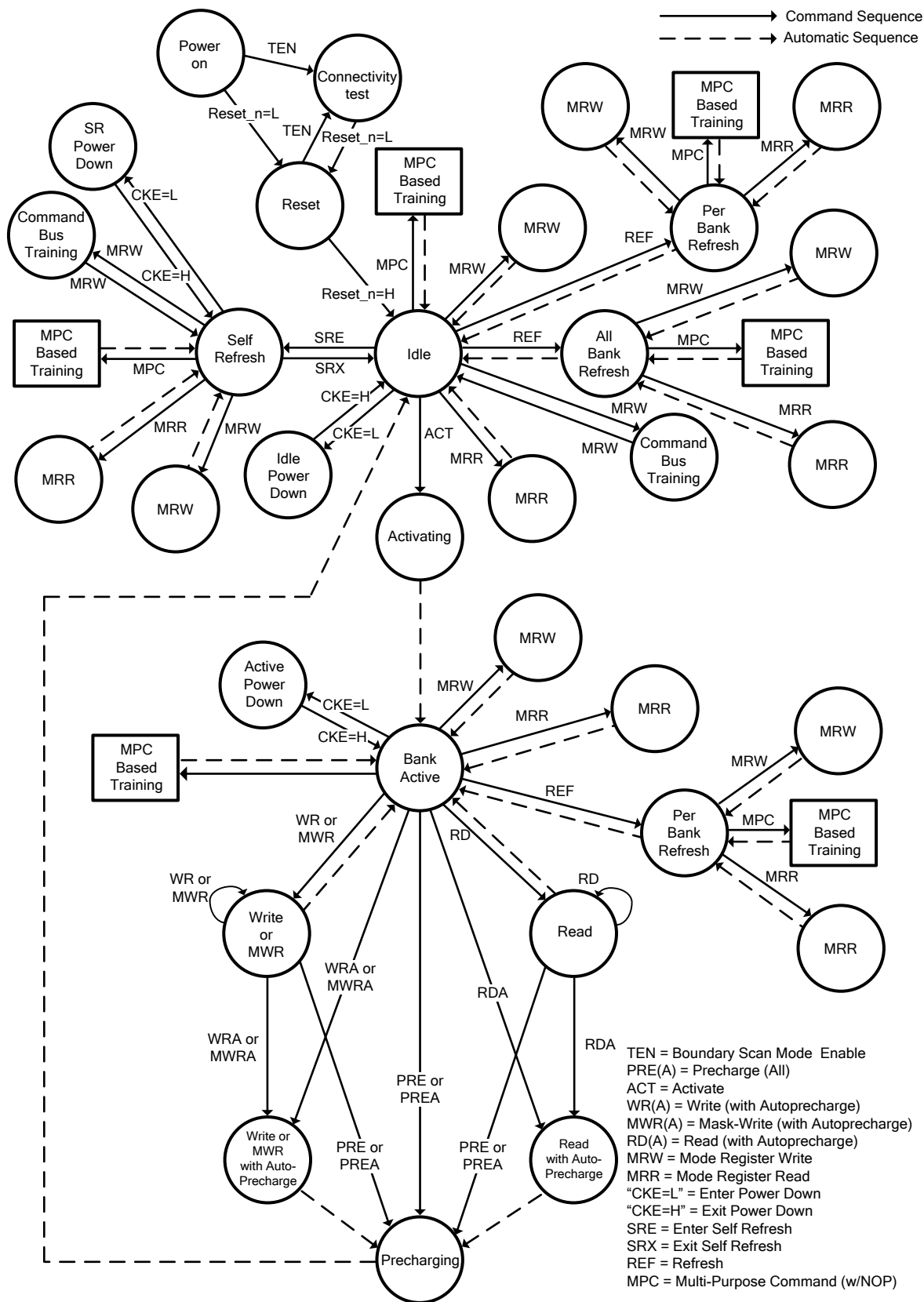
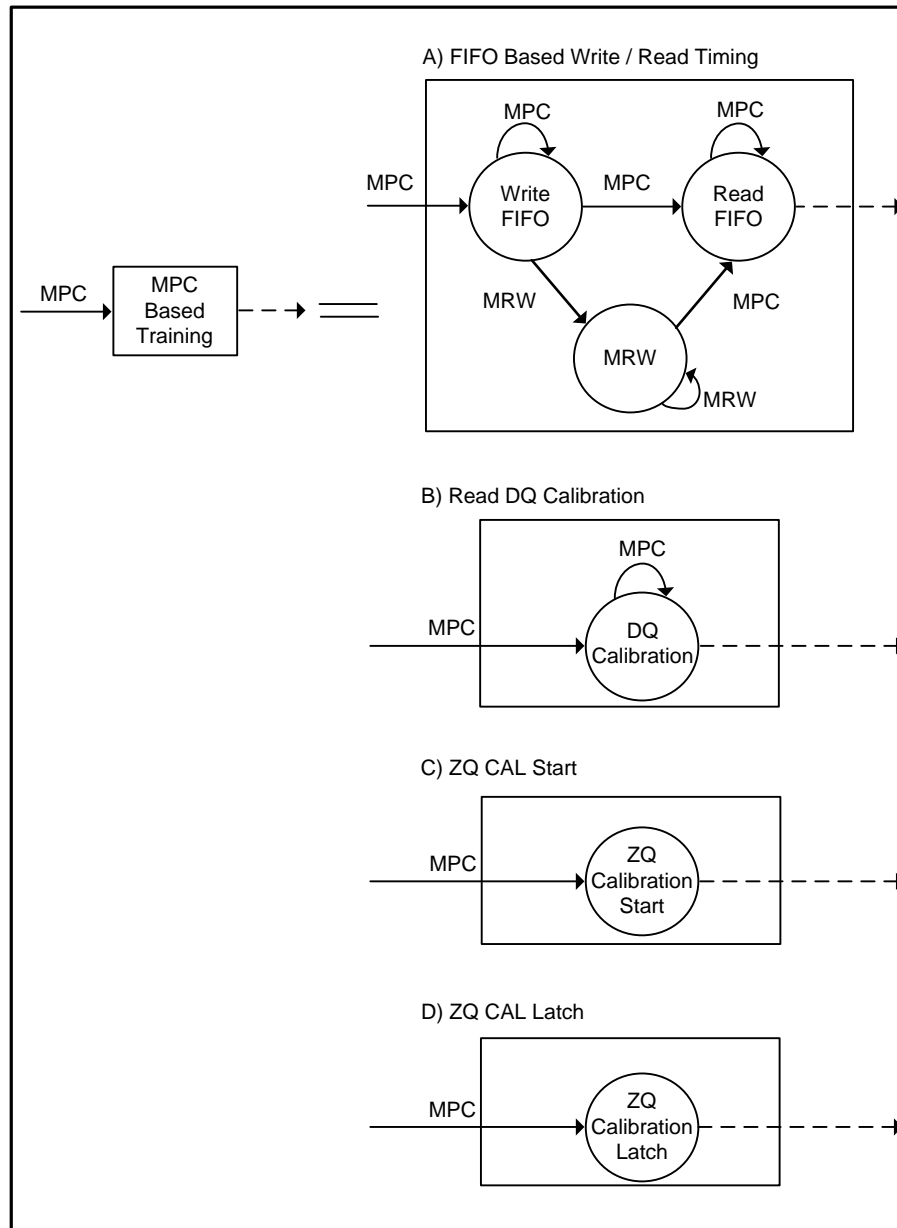

Figure 1 - Simplified Bus Interface State Diagram-1



**Figure 2 - Simplified Bus Interface State Diagram-2**

**Notes:**

1. From the Self Refresh state the device can enter Power-Down, MRR, MRW, or MPC states. See the section on Self Refresh for more information.
2. In IDLE state, all banks are precharged.
3. In the case of a MRW command to enter a training mode, the state machine will not automatically return to the IDLE state at the conclusion of training. See the applicable training section for more information.
4. In the case of a MPC command to enter a training mode, the state machine may not automatically return to the IDLE state at the conclusion of training. See the applicable training section for more information.
5. This simplified State Diagram is intended to provide an overview of the possible state transitions and the commands to control them. In particular, situations involving more than one bank, the enabling or disabling of on-die termination, and some other events are not captured in full detail.
6. States that have an "automatic return" and can be accessed from more than one prior state (Ex. MRW from either Idle or Active states) will return to the state from when they were initiated (Ex. MRW from Idle will return to Idle).
7. The RESET\_n pin can be asserted from any state, and will cause the SDRAM to go to the Reset State. The diagram shows RESET applied from the Power-On as an example, but the Diagram should not be construed as a restriction on RESET\_n.





## 7.2 Power-up, Initialization, and Power-Off Procedure

For power-up and reset initialization, in order to prevent DRAM from functioning improperly, default values of the following MR settings are defined as the table below.

**Table 1 - MRS defaults settings**

Item	MRS	Default Setting	Description
FSP-OP/WR	MR13 OP[7:6]	00b	FSP-OP/WR[0] are enabled
WLS	MR2 OP[6]	0b	Write Latency Set A is selected
WL	MR2 OP[5:3]	000b	WL = 4
RL	MR2 OP[2:0]	000b	RL = 6, nRTP=8
nWR	MR1 OP[6:4]	000b	nWR = 6
DBI-WR/RD	MR3 OP[7:6]	00b	Write & Read DBI are disabled
CA ODT	MR11 OP[6:4]	000b	CA ODT is disabled
DQ ODT	MR11 OP[2:0]	000b	DQ ODT is disabled
VREF(CA) Setting	MR12 OP[6]	1b	VREF(CA) Range[1] enabled
VREF(CA) Value	MR12 OP[5:0]	011101b	Range1 : 50.3% of VDDQ
VREF(DQ) Setting	MR14 OP[6]	1b	VREF(DQ) Range[1] enabled
VREF(DQ) Value	MR14 OP[5:0]	011101b	Range1 : 50.3% of VDDQ

### 7.2.1 Voltage Ramp and Device Initialization

The following sequence shall be used to power up the LPDDR4X device. Unless specified otherwise, these steps are mandatory. Note that the power-up sequence of all channels must proceed simultaneously.

- While applying power (after  $T_a$ ), RESET\_n is recommended to be LOW ( $\leq 0.2 \times VDD2$ ) and all other inputs must be between  $V_{ILmin}$  and  $V_{IHmax}$ . The device outputs remain at High-Z while RESET\_n is held LOW. Power supply voltage ramp requirements are provided in Table 2. VDD1 must ramp at the same time or earlier than VDD2. VDD2 must ramp at the same time or earlier than VDDQ.

**Table 2 - Voltage Ramp Conditions**

After	Applicable Conditions
Ta is reached	VDD1 must be greater than VDD2
	VDD2 must be greater than VDDQ—200mV

**Notes:**

- Ta is the point when any power supply first reaches 300 mV.
  - Noted voltage ramp conditions apply between Ta and power-off (controlled or uncontrolled).
  - Tb is the point at which all supply and reference voltages are within their defined ranges.
  - Power ramp duration tINIT0 (Tb - Ta) must not exceed 20 mS.
  - The voltage difference between of VSS and VSSQ pin must not exceed 100 mV.
- Following the completion of the voltage ramp (Tb), RESET\_n must be maintained LOW. DQ, DMI, DQS\_t and DQS\_c voltage levels must be between VSSQ and VDDQ during voltage ramp to avoid latch-up. CKE, CK\_t, CK\_c, CS\_n and CA input levels must be between VSS and VDD2 during voltage ramp to avoid latch-up.
  - Beginning at Tb, RESET\_n must remain LOW for at least tINIT1 (Tc), after which RESET\_n can be deasserted to HIGH (Tc). At least 10ns before RESET\_n de-assertion, CKE is required to be set LOW. All other input signals are "Don't Care".
  - After RESET\_n is de-asserted (Tc), wait at least tINIT3 before activating CKE. Clock (CK\_t, CK\_c) is required to be started and stabilized for tINIT4 before CKE goes active (Td). CS is required to be maintained LOW when controller activates CKE.
  - After setting CKE high, wait minimum of tINIT5 to issue any MRR or MRW commands (Te). For both MRR and MRW commands, the clock frequency must be within the range defined for tCKb. Some AC parameters (for example, tDQSK) could have relaxed timings (such as tDQSKb) before the system is appropriately configured.



6. After completing all MRW commands to set the Pull-up, Pull-down and Rx termination values, the DRAM controller can issue ZQCAL Start command to the memory (Tf). This command is used to calibrate VOH level and output impedance over process, voltage and temperature. In systems where more than one LPDDR4X DRAM devices share one external ZQ resistor, the controller must not overlap the ZQ calibration sequence of each LPDDR4X device. ZQ calibration sequence is completed after tZQCAL(Tg) and the ZQCAL Latch command must be issued to update the DQ drivers and DQ+CA ODT to the calibrated values.
7. After tZQLAT is satisfied (Th) the command bus (internal VREF (CA), CS, and CA) should be trained for high-speed operation by issuing an MRW command (Command Bus Training Mode). This command is used to calibrate the device's internal VREF and align CS/CA with CK for high-speed operation. The LPDDR4X device will power-up with receivers configured for low-speed operations, and VREF (CA) set to a default factory setting. Normal device operation at clock speeds higher than tCKb may not be possible until command bus training has been completed.
 

**NOTE:** The command bus training MRW command uses the CA bus as inputs for the calibration data stream, and outputs the results asynchronously on the DQ bus.
8. After command bus training, DRAM controller must perform write leveling. Write leveling mode is enabled when MR2 OP[7] is high (Ti). See "Mode Register Write-WR Leveling Mode", for detailed description of write leveling entry and exit sequence. In write leveling mode, the DRAM controller adjusts write DQS\_t/c timing to the point where the LPDDR4X device recognizes the start of write DQ data burst with desired write latency.
9. After write leveling, the DQ Bus (internal VREF (DQ), DQS, and DQ) should be trained for high-speed operation using the MPC training commands and by issuing MRW commands to adjust VREF (DQ) (Tj). The LPDDR4X device will power-up with receivers configured for low-speed operations and VREF (DQ) set to a default factory setting. Normal device operation at clock speeds higher than tCKb should not be attempted until DQ Bus training has been completed. The MPC Read Calibration command is used together with MPC FIFO Write/Read commands to train DQ bus without disturbing the memory array contents. See DQ Bus Training section for detailed DQ Bus Training sequence.
10. At Tk the LPDDR4X device is ready for normal operation, and is ready to accept any valid command. Any more registers that have not previously been set up for normal operation should be written at this time.

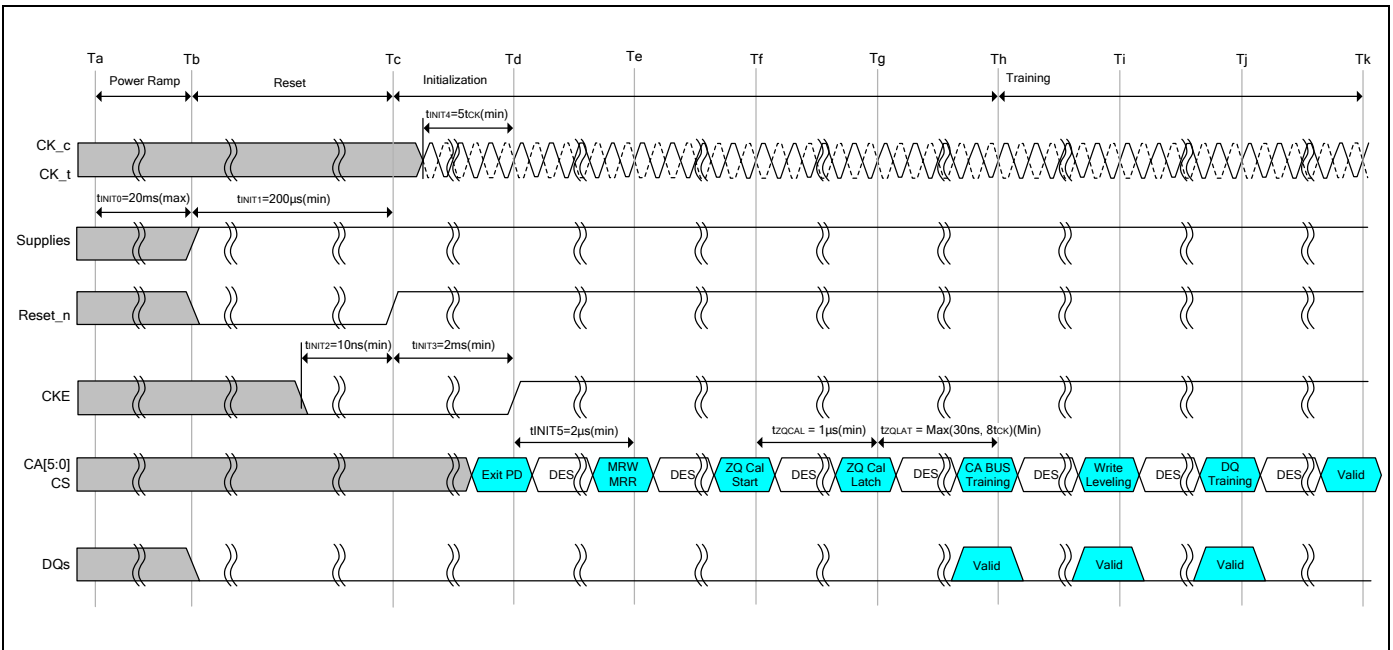

**Note:**

1. Training is optional and may be done at the system architects discretion. The training sequence after ZQ\_CAL Latch (Th, Sequence7~9) in Figure 3 is simplified recommendation and actual training sequence may vary depending on systems.

**Figure 3 - Power Ramp and Initialization Sequence**



Table 3 - Initialization Timing Parameters

Parameter	Value		Unit	Comment
	Min	Max		
tINIT0	-	20	mS	Maximum voltage-ramp time
tINIT1	200	-	μS	Minimum RESET_n LOW time after completion of voltage ramp
tINIT2	10	-	nS	Minimum CKE low time before RESET_n high
tINIT3	2	-	mS	Minimum CKE low time after RESET_n high
tINIT4	5	-	tCK	Minimum stable clock before first CKE high
tINIT5	2	-	μS	Minimum idle time before first MRW/MRR command
tZQCAL	1	-	μS	ZQ calibration time
tZQLAT	Max(30nS, 8tCK)	-	nS	ZQCAL latch quiet time
tCKb	Note*1,2	Note*1,2	nS	Clock cycle time during boot

**Notes:**

1. Min tCKb guaranteed by DRAM test is 18nS.
2. The system may boot at a higher frequency than dictated by min tCKb. The higher boot frequency is system dependent.

**7.2.2 Reset Initialization with Stable Power**

The following sequence is required for RESET at no power interruption initialization.

1. Assert RESET\_n below 0.2 x VDD2 anytime when reset is needed. RESET\_n needs to be maintained for minimum tPW\_RESET. CKE must be pulled LOW at least 10 nS before de-asserting RESET\_n.
2. Repeat steps 4 to 10 in "Voltage Ramp and Device Initialization" section.

Table 4 - Reset Timing Parameter

Symbol	Value		Unit	Comment
	min	max		
tPW_RESET	100		nS	Minimum RESET_n low Time for Reset Initialization with stable power

**7.2.3 Power-off Sequence**

The following procedure is required to power off the device.

While powering off, CKE must be held LOW ( $\leq 0.2 \times VDD2$ ) and all other inputs must be between VILmin and VIHmax. The device outputs remain at High-Z while CKE is held LOW. DQ, DMI, DQS\_t and DQS\_c voltage levels must be between VSSQ and VDDQ during voltage ramp to avoid latch-up. RESET\_n, CK\_t, CK\_c, CS and CA input levels must be between VSS and VDD2 during voltage ramp to avoid latch-up.

Tx is the point where any power supply drops below the minimum value specified.

Tz is the point where all power supplies are below 300 mV. After Tz, the device is powered off.

Table 5 - Power Supply Conditions

Between	Applicable Conditions
Tx and Tz	VDD1 must be greater than VDD2
	VDD2 must be greater than VDDQ - 200 mV

The voltage difference between of VSS, VSSQ pins must not exceed 100 mV.



#### 7.2.4 Uncontrolled Power-Off Sequence

When an uncontrolled power-off occurs, the following conditions must be met:

At Tx, when the power supply drops below the minimum values specified, all power supplies must be turned off and all power supply current capacity must be at zero, except any static charge remaining in the system.

After Tz (the point at which all power supplies first reach 300mV), the device must power off. During this period the relative voltage between power supplies is uncontrolled. VDD1 and VDD2 must decrease with a slope lower than  $0.5V/\mu S$  between Tx and Tz.

An uncontrolled power-off sequence can occur a maximum of 400 times over the life of the device.

**Table 6 - Timing Parameters Power-Off**

Symbol	Value		Unit	Comment
	min	max		
tPOFF	-	2	S	Maximum Power-Off Ramp Time



### 7.3 Mode Register Definition

The table listed below shows the mode registers for LPDDR4X SDRAM. A Mode Register Read command is used to read a mode register. A Mode Register Write command is used to write a mode register.

**Table 7 - Mode Register Assignment in LPDDR4X SDRAM**

MR#	OP[7]	OP[6]	OP[5]	OP[4]	OP[3]	OP[2]	OP[1]	OP[0]
0	Reserved	RFU	RFU	RZQI		RFU	Latency	Refresh
1	RPST	nWR (for AP)			RD-PRE	WR-PRE	BL	
2	WR Lev	WLS	WL			RL		
3	DBI-WR	DBI-RD	PPDS			PPRP	WR PST	PU-CAL
4	TUF	Thermal Offset		PPRE	SR Abort	Refresh Rate		
5	Manufacturer ID							
6	Revision ID-1							
7	Revision ID-2							
8	IO Width		Density				Type	
9	Vendor Specific Test Register							
10	RFU							ZQ-Reset
11	RFU	CA ODT			RFU	DQ ODT		
12	RFU	VR-CA	VREF(CA)					
13	FSP-OP	FSP-WR	DMD	RRO	VRCG	VRO	RPT	CBT
14	RFU	VR(dq)	VREF(DQ)					
15	Lower-Byte Invert Register for Calibration							
16	PASR Bank Mask							
17	PASR Segment Mask							
18	DQS Oscillator Count - LSB							
19	DQS Oscillator Count - MSB							
20	Upper-Byte Invert Register for DQ Calibration							
21	RFU							
22	Reserved	ODTD-CA	ODTE-CS	ODTE-CK	SOC ODT			
23	DQS interval timer run time setting							
24	TRR Mode	TRR Mode BAn			Unlimited	MAC	MAC Value	
25	PPR Resource							
26	RFU							
27	RFU							
28	RFU							
29	RFU							
30	Reserved for testing – SDRAM will ignore							
31	RFU							
32	DQ Calibration Pattern "A" (default = 5A <sub>H</sub> )							
33	RFU							
34	RFU							
35	RFU							
36	RFU							
37	RFU							
38	RFU							
39	Reserved for testing – SDRAM will ignore							
40	DQ Calibration Pattern "B" (default = 3C <sub>H</sub> )							



### 7.3.1 MR0 Register Information (MA[5:0] = 00H)

OP[7]	OP[6]	OP[5]	OP[4]	OP[3]	OP[2]	OP[1]	OP[0]
Reserved	RFU	RFU	RZQI		RFU	Latency Mode	Refresh Mode

Function	Type	Operand	Data	Notes
Refresh Mode	Read-only	OP[0]	<b>0b</b> : Both legacy and modified refresh mode supported (default) <b>1b</b> : Only modified refresh mode supported	
Latency Mode		OP[1]	<b>0b</b> : Device supports normal latency <b>1b</b> : Reserved	5
RZQI (Built-in Self-Test for RZQ)		OP[4:3]	<b>00b</b> : RZQ Self-Test not support. <b>01b</b> : ZQ-pin may connect to VSSQ or float <b>10b</b> : ZQ-pin may short to VDDQ <b>11b</b> : ZQ-pin Self-Test completed, no error condition detected (ZQ-pin may not connect to VSSQ or float ,nor short to VDDQ)	1, 2, 3, 4

#### Notes:

- RZQI MR value, if supported, will be valid after the following sequence:
  - Completion of MPC ZQCAL Start command to either channel.
  - Completion of MPC ZQCAL Latch command to either channel then tZQLAT is satisfied.  
RZQI value will be lost after Reset.
- If the ZQ-pin is connected to VSSQ to set default calibration, OP[4:3] shall be set to 01<sub>b</sub>. If the ZQ-pin is not connected to VSSQ, either OP[4:3] = 01<sub>b</sub> or OP[4:3] = 10<sub>b</sub> might indicate a ZQ-pin assembly error. It is recommended that the assembly error is corrected.
- In the case of possible assembly error, the LPDDR4X-SDRAM device will default to factory trim settings for RON, and will ignore ZQ Calibration commands. In either case, the device may not function as intended.
- If ZQ Self-Test returns OP[4:3] = 11<sub>b</sub>, the device has detected a resistor connected to the ZQ-pin. However, this result cannot be used to validate the ZQ resistor value or that the ZQ resistor tolerance meets the specified limits (i.e. 240Ω ± 1%).
- Byte mode is not supported.





## 7.3.2 MR1 Register Information (MA[5:0] = 01H)

OP[7]	OP[6]	OP[5]	OP[4]	OP[3]	OP[2]	OP[1]	OP[0]
RPST	nWR (for AP)			RD-PRE	WR-PRE	BL	

Function	Type	Operand	Data	Notes
BL (Burst Length)	Write only	OP[1:0]	<b>00<sub>b</sub></b> : BL=16 Sequential (default) <b>01<sub>b</sub></b> : BL=32 Sequential <b>10<sub>b</sub></b> : BL=16 or 32 Sequential (on-the-fly) All Others: Reserved	1
WR-PRE (WR Pre-amble Length)		OP[2]	<b>0<sub>b</sub></b> : Reserved <b>1<sub>b</sub></b> : WR Pre-amble = 2*tCK	5, 6
RD-PRE (RD Pre-amble Type)		OP[3]	<b>0<sub>b</sub></b> : RD Pre-amble = Static (default) <b>1<sub>b</sub></b> : RD Pre-amble = Toggle	3, 5, 6
nWR (Write-Recovery for Auto-Precharge commands)		OP[6:4]	<b>000<sub>b</sub></b> : nWR = 6 (default) <b>001<sub>b</sub></b> : nWR = 10 <b>010<sub>b</sub></b> : nWR = 16 <b>011<sub>b</sub></b> : nWR = 20 <b>100<sub>b</sub></b> : nWR = 24 <b>101<sub>b</sub></b> : nWR = 30 <b>110<sub>b</sub></b> : nWR = 34 <b>111<sub>b</sub></b> : nWR = 40	2, 5, 6
RPST (RD Post-Ambles Length)		OP[7]	<b>0<sub>b</sub></b> : RD Post-ambles = 0.5*tCK (default) <b>1<sub>b</sub></b> : RD Post-ambles = 1.5*tCK	4, 5, 6

**Notes:**

- Burst length on-the-fly can be set to either BL=16 or BL=32 by setting the "BL" bit in the command operands.
- The programmed value of nWR is the number of clock cycles the LPDDR4X-SDRAM device uses to determine the starting point of an internal Precharge operation after a Write burst with AP (auto-precharge) enabled.
- For Read operations this bit must be set to select between a "toggling" pre-ambles and a "Non-toggling" Pre-ambles.
- OP[7] provides an alternative READ post-ambles with an additional rising and falling edge of DQS<sub>t</sub>. This alternative postambles cycle is provided for the benefit of certain memory controllers.
- There are two physical registers assigned to each bit of this MR parameter, designated set point 0 and set point 1. Only the registers for the set point determined by the state of the FSP-WR bit (MR13 OP[6]) will be written to with an MRW command to this MR address, or read from with an MRR command to this address.
- There are two physical registers assigned to each bit of this MR parameter, designated set point 0 and set point 1. The device will operate only according to the values stored in the registers for the active set point, i.e., the set point determined by the state of the FSP-OP bit (MR13 OP[7]). The values in the registers for the inactive set point will be ignored by the device, and may be changed without affecting device operation.



Table 8 - Burst Sequence for READ

Burst Length	Burst Type	C4	C3	C2	C1	C0	Burst Cycle Number and Burst Address Sequence																																			
							1	2	3	4	5	6	7	8	9	10	11	12	13	14	15	16	17	18	19	20	21	22	23	24	25	26	27	28	29	30	31	32				
16	SEQ	V	0	0	0	0	0	1	2	3	4	5	6	7	8	9	A	B	C	D	E	F																				
		V	0	1	0	0	4	5	6	7	8	9	A	B	C	D	E	F	0	1	2	3																				
		V	1	0	0	0	8	9	A	B	C	D	E	F	0	1	2	3	4	5	6	7																				
		V	1	1	0	0	C	D	E	F	0	1	2	3	4	5	6	7	8	9	A	B																				
32	SEQ	0	0	0	0	0	0	1	2	3	4	5	6	7	8	9	A	B	C	D	E	F	10	11	12	13	14	15	16	17	18	19	1A	1B	1C	1D	1E	1F				
		0	0	1	0	0	4	5	6	7	8	9	A	B	C	D	E	F	0	1	2	3	14	15	16	17	18	19	1A	1B	1C	1D	1E	1F	10	11	12	13				
		0	1	0	0	0	8	9	A	B	C	D	E	F	0	1	2	3	4	5	6	7	18	19	1A	1B	1C	1D	1E	1F	10	11	12	13	14	15	16	17				
		0	1	1	0	0	C	D	E	F	0	1	2	3	4	5	6	7	8	9	A	B	1C	1D	1E	1F	10	11	12	13	14	15	16	17	18	19	1A	1B				
		1	0	0	0	0	10	11	12	13	14	15	16	17	18	19	1A	1B	1C	1D	1E	1F	0	1	2	3	4	5	6	7	8	9	A	B	C	D	E	F				
		1	0	1	0	0	14	15	16	17	18	19	1A	1B	1C	1D	1E	1F	10	11	12	13	4	5	6	7	8	9	A	B	C	D	E	F	0	1	2	3				
		1	1	0	0	0	18	19	1A	1B	1C	1D	1E	1F	10	11	12	13	14	15	16	17	8	9	A	B	C	D	E	F	0	1	2	3	4	5	6	7				
1	1	1	0	0	1C	1D	1E	1F	10	11	12	13	14	15	16	17	18	19	1A	1B	C	D	E	F	0	1	2	3	4	5	6	7	8	9	A	B						

Notes:

1. C0-C1 are assumed to be '0', and are not transmitted on the command bus.
2. The starting burst address is on 64-bit (4n) boundaries.

Table 9 - Burst Sequence for Write

Burst Length	Burst Type	C4	C3	C2	C1	C0	Burst Cycle Number and Burst Address Sequence																																	
							1	2	3	4	5	6	7	8	9	10	11	12	13	14	15	16	17	18	19	20	21	22	23	24	25	26	27	28	29	30	31	32		
16	SEQ	V	0	0	0	0	0	1	2	3	4	5	6	7	8	9	A	B	C	D	E	F																		
32	SEQ	0	0	0	0	0	0	1	2	3	4	5	6	7	8	9	A	B	C	D	E	F	10	11	12	13	14	15	16	17	18	19	1A	1B	1C	1D	1E	1F		

Notes:

1. C0-C1 are assumed to be '0', and are not transmitted on the command bus.
2. The starting address is on 256-bit (16n) boundaries for Burst length 16.
3. The starting address is on 512-bit (32n) boundaries for Burst length 32.
4. C2-C3 shall be set to '0' for all Write operations.



## 7.3.3 MR2 Register Information (MA[5:0] = 02H)

OP[7]	OP[6]	OP[5]	OP[4]	OP[3]	OP[2]	OP[1]	OP[0]
WR Lev	WLS	WL			RL		

Function	Type	Operand	Data	Notes
RL (Read Latency)	Write-only	OP[2:0]	<b>RL &amp; nRTP for DBI-RD Disabled (MR3 OP[6]= 0<sub>b</sub>)</b> <b>000<sub>b</sub></b> : RL=6, nRTP = 8 (Default) <b>001<sub>b</sub></b> : RL=10, nRTP = 8 <b>010<sub>b</sub></b> : RL=14, nRTP = 8 <b>011<sub>b</sub></b> : RL=20, nRTP = 8 <b>100<sub>b</sub></b> : RL=24, nRTP = 10 <b>101<sub>b</sub></b> : RL=28, nRTP = 12 <b>110<sub>b</sub></b> : RL=32, nRTP = 14 <b>111<sub>b</sub></b> : RL=36, nRTP = 16 <b>RL &amp; nRTP for DBI-RD Enabled (MR3 OP[6]= 1<sub>b</sub>)</b> <b>000<sub>b</sub></b> : RL=6, nRTP = 8 <b>001<sub>b</sub></b> : RL=12, nRTP = 8 <b>010<sub>b</sub></b> : RL=16, nRTP = 8 <b>011<sub>b</sub></b> : RL=22, nRTP = 8 <b>100<sub>b</sub></b> : RL=28, nRTP = 10 <b>101<sub>b</sub></b> : RL=32, nRTP = 12 <b>110<sub>b</sub></b> : RL=36, nRTP = 14 <b>111<sub>b</sub></b> : RL=40, nRTP = 16	1, 3, 4
WL (Write Latency)		OP[5:3]	<b>WL Set "A" (MR2 OP[6]= 0<sub>b</sub>)</b> <b>000<sub>b</sub></b> : WL=4 (Default) <b>001<sub>b</sub></b> : WL=6 <b>010<sub>b</sub></b> : WL=8 <b>011<sub>b</sub></b> : WL=10 <b>100<sub>b</sub></b> : WL=12 <b>101<sub>b</sub></b> : WL=14 <b>110<sub>b</sub></b> : WL=16 <b>111<sub>b</sub></b> : WL=18 <b>WL Set "B" (MR2 OP[6]= 1<sub>b</sub>)</b> <b>000<sub>b</sub></b> : WL=4 <b>001<sub>b</sub></b> : WL=8 <b>010<sub>b</sub></b> : WL=12 <b>011<sub>b</sub></b> : WL=18 <b>100<sub>b</sub></b> : WL=22 <b>101<sub>b</sub></b> : WL=26 <b>110<sub>b</sub></b> : WL=30 <b>111<sub>b</sub></b> : WL=34	1, 3, 4
WLS (Write Latency Set)		OP[6]	<b>0<sub>b</sub></b> : WL Set "A" (default) <b>1<sub>b</sub></b> : WL Set "B"	1, 3, 4
WR LEV (Write Leveling)		OP[7]	<b>0<sub>b</sub></b> : Disabled (default) <b>1<sub>b</sub></b> : Enabled	2

**Notes:**

1. See Latency Code Frequency Table for allowable Frequency Ranges for RL/WL/nWR/nRTP.
2. After a MRW to set the Write Leveling Enable bit (OP[7]= 1<sub>b</sub>), the LPDDR4X-SDRAM device remains in the MRW state until another MRW command clears the bit (OP[7]= 0<sub>b</sub>). No other commands are allowed until the Write Leveling Enable bit is cleared.
3. There are two physical registers assigned to each bit of this MR parameter, designated set point 0 and set point 1. Only the registers for the set point determined by the state of the FSP-WR bit (MR13 OP[6]) will be written to with an MRW command to this MR address, or read from with an MRR command to this address.
4. There are two physical registers assigned to each bit of this MR parameter, designated set point 0 and set point 1. The device will operate only according to the values stored in the registers for the active set point, i.e., the set point determined by the state of the FSP-OP bit (MR13 OP[7]). The values in the registers for the inactive set point will be ignored by the device, and may be changed without affecting device operation.



## 7.3.4 MR3 Register Information (MA[5:0] = 03H)

OP[7]	OP[6]	OP[5]	OP[4]	OP[3]	OP[2]	OP[1]	OP[0]
DBI-WR	DBI-RD	PDDS			PPRP	WR PST	PU-CAL

Function	Type	Operand	Data	Notes
PU-Cal (Pull-up Calibration Point)	Write only	OP[0]	<b>0<sub>b</sub></b> : VDDQ*0.6 <b>1<sub>b</sub></b> : VDDQ*0.5 (default)	1, 4
WR PST (WR Post-Ambler Length)		OP[1]	<b>0<sub>b</sub></b> : WR Post-ambler = 0.5*tCK (default) <b>1<sub>b</sub></b> : WR Post-ambler = 1.5*tCK	2, 3, 5
Post Package Repair Protection		OP[2]	<b>0<sub>b</sub></b> : PPR protection disabled (default) <b>1<sub>b</sub></b> : PPR protection enabled	6
PDDS (Pull-Down Drive strength)		OP[5:3]	<b>000<sub>b</sub></b> : RFU <b>001<sub>b</sub></b> : RZQ/1 <b>010<sub>b</sub></b> : RZQ/2 <b>011<sub>b</sub></b> : RZQ/3 <b>100<sub>b</sub></b> : RZQ/4 <b>101<sub>b</sub></b> : RZQ/5 <b>110<sub>b</sub></b> : RZQ/6 (default) <b>111<sub>b</sub></b> : Reserved	1, 2, 3
DBI-RD (DBI-Read Enable)		OP[6]	<b>0<sub>b</sub></b> : Disabled (default) <b>1<sub>b</sub></b> : Enabled	2, 3
DBI-WR (DBI-Write Enable)		OP[7]	<b>0<sub>b</sub></b> : Disabled (default) <b>1<sub>b</sub></b> : Enabled	2, 3

**Notes:**

- All values are "typical". The actual value after calibration will be within the specified tolerance for a given voltage and temperature. Re-calibration may be required as voltage and temperature vary.
- There are two physical registers assigned to each bit of this MR parameter, designated set point 0 and set point 1. Only the registers for the set point determined by the state of the FSP-WR bit (MR13 OP[6]) will be written to with an MRW command to this MR address, or read from with an MRR command to this address.
- There are two physical registers assigned to each bit of this MR parameter, designated set point 0 and set point 1. The device will operate only according to the values stored in the registers for the active set point, i.e., the set point determined by the state of the FSP-OP bit (MR13 OP[7]). The values in the registers for the inactive set point will be ignored by the device, and may be changed without affecting device operation.
- PU-CAL setting is required as the same value for both Ch.A and Ch.B before issuing ZQ Cal start command.
- 1.5\*tCK apply > 1.6GHz clock.
- If MR3 OP[2] is set to 1<sub>b</sub> then PPR protection mode is enabled. The PPR Protection bit is a sticky bit and can only be set to 0<sub>b</sub> by a power on reset. MR4 OP[4] controls entry to PPR Mode. If PPR protection is enabled then DRAM will not allow writing of 1 to MR4 OP[4].



### 7.3.5 MR4 Register Information (MA[5:0] = 04H)

OP[7]	OP[6]	OP[5]	OP[4]	OP[3]	OP[2]	OP[1]	OP[0]
TUF	Thermal Offset		PPRE	SR Abort	Refresh Rate		

Function	Type	Operand	Data	Notes
Refresh Rate	Read-only	OP[2:0]	<b>000<sub>b</sub></b> : SDRAM Low temperature operating limit exceeded <b>001<sub>b</sub></b> : 4x refresh <b>010<sub>b</sub></b> : 2x refresh <b>011<sub>b</sub></b> : 1x refresh (default) <b>100<sub>b</sub></b> : 0.5x refresh <b>101<sub>b</sub></b> : 0.25x refresh, no de-rating <b>110<sub>b</sub></b> : 0.25x refresh, with de-rating <b>111<sub>b</sub></b> : SDRAM High temperature operating limit exceeded	1, 2, 3, 6, 7, 8
SR Abort (Self Refresh Abort)	Write-only	OP[3]	<b>0<sub>b</sub></b> : Disable (default) <b>1<sub>b</sub></b> : Reserved	8
PPRE (Post-package repair entry/exit)	Write-only	OP[4]	<b>0<sub>b</sub></b> : Exit PPR mode (default) <b>1<sub>b</sub></b> : Enter PPR mode	4, 8
Thermal Offset	Write-only	OP[6:5]	<b>00<sub>b</sub></b> : No offset, 0~5°C gradient (default) <b>01<sub>b</sub></b> : 5°C offset, 5~10°C gradient <b>10<sub>b</sub></b> : 10°C offset, 10~15°C gradient <b>11<sub>b</sub></b> : Reserved	
TUF (Temperature Update Flag)	Read-only	OP7	<b>0<sub>b</sub></b> : No change in OP[2:0] since last MR4 read (default) <b>1<sub>b</sub></b> : Change in OP[2:0] since last MR4 read	5, 6, 7

#### Notes:

- The refresh rate for each MR4-OP[2:0] setting applies to tREFI, tREFIpb, and tREFW. OP[2:0]=011<sub>b</sub> corresponds to a device temperature of 85°C. Other values require either a longer (2x, 4x) refresh interval at lower temperatures, or a shorter (0.5x, 0.25x) refresh interval at higher temperatures. If OP[2]=1<sub>b</sub>, the device temperature is greater than 85°C.
- At higher temperatures (>85°C), AC timing derating may be required. If derating is required the LPDDR4X-SDRAM will set OP[2:0]=110<sub>b</sub>.
- The device may not operate properly when OP[2:0]=000<sub>b</sub> or 111<sub>b</sub>.
- Post-package repair can be entered or exited by writing to OP[4].
- When OP[7]=1, the refresh rate reported in OP[2:0] has changed since the last MR4 read. A mode register read from MR4 will reset OP[7] to '0'.
- OP[7] = 0 at power-up. OP[2:0] bits are valid after initialization sequence (Te).
- See "**Temperature Sensor**" section for information on the recommended frequency of reading MR4.
- OP[6:3] bits that can be written in this register. All other bits will be ignored by the DRAM during a MRW to this register.



## 7.3.6 MR5 Register Information (MA[5:0] = 05H)

OP[7]	OP[6]	OP[5]	OP[4]	OP[3]	OP[2]	OP[1]	OP[0]
Manufacturer ID							

Function	Type	Operand	Data	Note
Manufacturer ID	Read-only	OP[7:0]	0000 1000 <sub>b</sub> : Winbond	

## 7.3.7 MR6 Register Information (MA[5:0] = 06H)

OP[7]	OP[6]	OP[5]	OP[4]	OP[3]	OP[2]	OP[1]	OP[0]
Revision ID-1							

Function	Type	Operand	Data	Note
Revision ID-1	Read-only	OP[7:0]	TBD	

## 7.3.8 MR7 Register Information (MA[5:0] = 07H)

OP[7]	OP[6]	OP[5]	OP[4]	OP[3]	OP[2]	OP[1]	OP[0]
Revision ID-2							

Function	Type	Operand	Data	Note
Revision ID-2	Read-only	OP[7:0]	TBD	

## 7.3.9 MR8 Register Information (MA[5:0] = 08H)

OP[7]	OP[6]	OP[5]	OP[4]	OP[3]	OP[2]	OP[1]	OP[0]
I/O width		Density				Type	

Function	Type	Operand	Data	Note
Type	Read-only	OP[1:0]	<b>00<sub>b</sub></b> : S16 SDRAM (16n pre-fetch) <b>All others</b> : Reserved	
Density		OP[5:2]	<b>0000<sub>b</sub></b> : 4Gb dual channel package / 2Gb single channel package <b>All others</b> : Reserved	
I/O width		OP[7:6]	<b>00<sub>b</sub></b> : x16 (per channel) <b>All others</b> : Reserved	

## 7.3.10 MR9 Register Information (MA[5:0] = 09H)

## 7.3.11 MR10 Register Information (MA[5:0] = 0AH)

OP[7]	OP[6]	OP[5]	OP[4]	OP[3]	OP[2]	OP[1]	OP[0]
RFU							ZQ-Reset

Function	Type	Operand	Data	Notes
ZQ-Reset	Write-only	OP[0]	<b>0<sub>b</sub></b> : Normal Operation (Default) <b>1<sub>b</sub></b> : ZQ Reset	1, 2

## Notes:

- See ZQCal Timing Parameters for calibration latency and timing.
- If the ZQ-pin is connected to VDDQ through RZQ, either the ZQ calibration function or default calibration (via ZQ-Reset) is supported. If the ZQ-pin is connected to VSS, the device operates with default calibration, and ZQ calibration commands are ignored. In both cases, the ZQ connection shall not change after power is applied to the device.





### 7.3.12 MR11 Register Information (MA[5:0] = 0B<sub>H</sub>)

OP[7]	OP[6]	OP[5]	OP[4]	OP[3]	OP[2]	OP[1]	OP[0]
RFU	CA ODT			RFU	DQ ODT		

Function	Type	Operand	Data	Notes
DQ ODT (DQ Bus Receiver On-Die-Termination)	Write-only	OP[2:0]	<b>000<sub>b</sub></b> : Disable (Default) <b>001<sub>b</sub></b> : RZQ/1 <b>010<sub>b</sub></b> : RZQ/2 <b>011<sub>b</sub></b> : RZQ/3 <b>100<sub>b</sub></b> : RZQ/4 <b>101<sub>b</sub></b> : RZQ/5 <b>110<sub>b</sub></b> : RZQ/6 <b>111<sub>b</sub></b> : Reserved	1, 2, 3
CA ODT (CA Bus Receiver On-Die-Termination)		OP[6:4]	<b>000<sub>b</sub></b> : Disable (Default) <b>001<sub>b</sub></b> : RZQ/1 <b>010<sub>b</sub></b> : RZQ/2 <b>011<sub>b</sub></b> : RZQ/3 <b>100<sub>b</sub></b> : RZQ/4 <b>101<sub>b</sub></b> : RZQ/5 <b>110<sub>b</sub></b> : RZQ/6 <b>111<sub>b</sub></b> : Reserved	1, 2, 3

#### Notes:

- All values are "typical". The actual value after calibration will be within the specified tolerance for a given voltage and temperature. Re-calibration may be required as voltage and temperature vary.
- There are two physical registers assigned to each bit of this MR parameter, designated set point 0 and set point 1. Only the registers for the set point determined by the state of the FSP-WR bit (MR13 OP[6]) will be written to with an MRW command to this MR address, or read from with an MRR command to this address.
- There are two physical registers assigned to each bit of this MR parameter, designated set point 0 and set point 1. The device will operate only according to the values stored in the registers for the active set point, i.e., the set point determined by the state of the FSP-OP bit (MR13 OP[7]). The values in the registers for the inactive set point will be ignored by the device, and may be changed without affecting device operation.

### 7.3.13 MR12 Register Information (MA[5:0] = 0C<sub>H</sub>)

OP[7]	OP[6]	OP[5]	OP[4]	OP[3]	OP[2]	OP[1]	OP[0]
RFU	VR-CA	VREF(CA)					

Function	Type	Operand	Data	Notes
VREF(CA) (VREF(CA) Setting)	Read/Write	OP[5:0]	<b>000000<sub>b</sub></b> : -- Thru -- <b>110010<sub>b</sub></b> : See table below <b>All Others: Reserved</b>	1, 2, 3, 5, 6
VR-CA (VREF(CA) Range)		OP[6]	<b>0<sub>b</sub></b> : VREF(CA) Range[0] enabled <b>1<sub>b</sub></b> : VREF(CA) Range[1] enabled (default)	1, 2, 4, 5, 6

#### Notes:

- This register controls the VREF(CA) levels. Refer to Table 10 - VREF Settings for Range[0] and Range[1] for actual voltage of VREF(CA).
- A read to this register places the contents of OP[7:0] on DQ[7:0]. Any RFU bits and unused DQ's shall be set to '0'. See the section on MRR Operation.
- A write to OP[5:0] sets the internal VREF(CA) level for FSP[0] when MR13 OP[6]= 0<sub>b</sub>, or sets the internal VREF(CA) level for FSP[1] when MR13 OP[6]=1<sub>b</sub>. The time required for VREF(CA) to reach the set level depends on the step size from the current level to the new level. See the section on VREF(CA) training for more information.
- A write to OP[6] switches the LPDDR4X-SDRAM between two internal VREF(CA) ranges. The range (Range[0] or Range[1]) must be selected when setting the VREF(CA) register. The value, once set, will be retained until over written, or until the next power-on or RESET event.
- There are two physical registers assigned to each bit of this MR parameter, designated set point 0 and set point 1. Only the registers for the set point determined by the state of the FSP-WR bit (MR13 OP[6]) will be written to with an MRW command to this MR address, or read from with an MRR command to this address.
- There are two physical registers assigned to each bit of this MR parameter, designated set point 0 and set point 1. The device will operate only according to the values stored in the registers for the active set point, i.e., the set point determined by the state of the FSP-OP bit (MR13 OP[7]). The values in the registers for the inactive set point will be ignored by the device, and may be changed without affecting device operation.



Table 10 - VREF Settings for Range[0] and Range[1]

Function	Operand	Range[0] Values (% of VDDQ)		Range[1] Values (% of VDDQ)		Notes
VREF Settings for MR12	OP[5:0]	000000 <sub>b</sub> : 15.0%	011010 <sub>b</sub> : 30.5%	000000 <sub>b</sub> : 32.9%	011010 <sub>b</sub> : 48.5%	1, 2, 3
		000001 <sub>b</sub> : 15.6%	011011 <sub>b</sub> : 31.1%	000001 <sub>b</sub> : 33.5%	011011 <sub>b</sub> : 49.1%	
		000010 <sub>b</sub> : 16.2%	011100 <sub>b</sub> : 31.7%	000010 <sub>b</sub> : 34.1%	011100 <sub>b</sub> : 49.7%	
		000011 <sub>b</sub> : 16.8%	011101 <sub>b</sub> : 32.3%	000011 <sub>b</sub> : 34.7%	011101 <sub>b</sub> : 50.3% (Default)	
		000100 <sub>b</sub> : 17.4%	011110 <sub>b</sub> : 32.9%	000100 <sub>b</sub> : 35.3%	011110 <sub>b</sub> : 50.9%	
		000101 <sub>b</sub> : 18.0%	011111 <sub>b</sub> : 33.5%	000101 <sub>b</sub> : 35.9%	011111 <sub>b</sub> : 51.5%	
		000110 <sub>b</sub> : 18.6%	100000 <sub>b</sub> : 34.1%	000110 <sub>b</sub> : 36.5%	100000 <sub>b</sub> : 52.1%	
		000111 <sub>b</sub> : 19.2%	100001 <sub>b</sub> : 34.7%	000111 <sub>b</sub> : 37.1%	100001 <sub>b</sub> : 52.7%	
		001000 <sub>b</sub> : 19.8%	100010 <sub>b</sub> : 35.3%	001000 <sub>b</sub> : 37.7%	100010 <sub>b</sub> : 53.3%	
		001001 <sub>b</sub> : 20.4%	100011 <sub>b</sub> : 35.9%	001001 <sub>b</sub> : 38.3%	100011 <sub>b</sub> : 53.9%	
		001010 <sub>b</sub> : 21.0%	100100 <sub>b</sub> : 36.5%	001010 <sub>b</sub> : 38.9%	100100 <sub>b</sub> : 54.5%	
		001011 <sub>b</sub> : 21.6%	100101 <sub>b</sub> : 37.1%	001011 <sub>b</sub> : 39.5%	100101 <sub>b</sub> : 55.1%	
		001100 <sub>b</sub> : 22.2%	100110 <sub>b</sub> : 37.7%	001100 <sub>b</sub> : 40.1%	100110 <sub>b</sub> : 55.7%	
		001101 <sub>b</sub> : 22.8%	100111 <sub>b</sub> : 38.3%	001101 <sub>b</sub> : 40.7%	100111 <sub>b</sub> : 56.3%	
		001110 <sub>b</sub> : 23.4%	101000 <sub>b</sub> : 38.9%	001110 <sub>b</sub> : 41.3%	101000 <sub>b</sub> : 56.9%	
		001111 <sub>b</sub> : 24.0%	101001 <sub>b</sub> : 39.5%	001111 <sub>b</sub> : 41.9%	101001 <sub>b</sub> : 57.5%	
		010000 <sub>b</sub> : 24.6%	101010 <sub>b</sub> : 40.1%	010000 <sub>b</sub> : 42.5%	101010 <sub>b</sub> : 58.1%	
		010001 <sub>b</sub> : 25.1%	101011 <sub>b</sub> : 40.7%	010001 <sub>b</sub> : 43.1%	101011 <sub>b</sub> : 58.7%	
		010010 <sub>b</sub> : 25.7%	101100 <sub>b</sub> : 41.3%	010010 <sub>b</sub> : 43.7%	101100 <sub>b</sub> : 59.3%	
		010011 <sub>b</sub> : 26.3%	101101 <sub>b</sub> : 41.9%	010011 <sub>b</sub> : 44.3%	101101 <sub>b</sub> : 59.9%	
		010100 <sub>b</sub> : 26.9%	101110 <sub>b</sub> : 42.5%	010100 <sub>b</sub> : 44.9%	101110 <sub>b</sub> : 60.5%	
		010101 <sub>b</sub> : 27.5%	101111 <sub>b</sub> : 43.1%	010101 <sub>b</sub> : 45.5%	101111 <sub>b</sub> : 61.1%	
		010110 <sub>b</sub> : 28.1%	110000 <sub>b</sub> : 43.7%	010110 <sub>b</sub> : 46.1%	110000 <sub>b</sub> : 61.7%	
		010111 <sub>b</sub> : 28.7%	110001 <sub>b</sub> : 44.3%	010111 <sub>b</sub> : 46.7%	110001 <sub>b</sub> : 62.3%	
011000 <sub>b</sub> : 29.3%	110010 <sub>b</sub> : 44.9%	011000 <sub>b</sub> : 47.3%	110010 <sub>b</sub> : 62.9%			
011001 <sub>b</sub> : 29.9%	All Others: Reserved	011001 <sub>b</sub> : 47.9%	All Others: Reserved			

**Notes:**

1. These values may be used for MR12 OP[5:0] to set the VREF(CA) levels in the LPDDR4X-SDRAM.
2. The range may be selected in the MR12 register by setting OP[6] appropriately.
3. The MR12 registers represents either FSP[0] or FSP[1]. Two frequency-set-points each for CA and DQ are provided to allow for faster switching between terminated and un-terminated operation, or between different high frequency setting which may use different terminations values.

7.3.14 MR13 Register Information (MA[5:0] = 0D<sub>H</sub>)

OP[7]	OP[6]	OP[5]	OP[4]	OP[3]	OP[2]	OP[1]	OP[0]
FSP-OP	FSP-WR	DMD	RRO	VRCG	VRO	RPT	CBT

Function	Type	Operand	Data	Notes
CBT (Command Bus Training)	Write-only	OP[0]	<b>0<sub>b</sub></b> : Normal Operation (default) <b>1<sub>b</sub></b> : Command Bus Training Mode Enabled	1
RPT (Read Preamble Training Mode)		OP[1]	<b>0<sub>b</sub></b> : Disable (default) <b>1<sub>b</sub></b> : Enable	
VRO (VREF Output)		OP[2]	<b>0<sub>b</sub></b> : Normal Operation (default) <b>1<sub>b</sub></b> : Output the VREF(CA) and VREF(DQ) values on DQ bits	2
VRCG (VREF Current Generator)		OP[3]	<b>0<sub>b</sub></b> : Normal Operation (default) <b>1<sub>b</sub></b> : VREF Fast Response (high current) mode	3
RRO Refresh rate option		OP[4]	<b>0<sub>b</sub></b> : Disable codes 001 and 010 in MR4 OP[2:0] <b>1<sub>b</sub></b> : Enable all codes in MR4 OP[2:0]	4, 5
DMD (Data Mask Disable)		OP[5]	<b>0<sub>b</sub></b> : Data Mask Operation Enabled (default) <b>1<sub>b</sub></b> : Data Mask Operation Disabled	6
FSP-WR (Frequency Set Point Write/Read)		OP[6]	<b>0<sub>b</sub></b> : Frequency-Set-Point[0] (default) <b>1<sub>b</sub></b> : Frequency-Set-Point [1]	7
FSP-OP (Frequency Set Point Operation Mode)		OP7	<b>0<sub>b</sub></b> : Frequency-Set-Point[0] (default) <b>1<sub>b</sub></b> : Frequency-Set-Point [1]	8

**Notes:**

1. A write to set OP[0]=1 causes the LPDDR4X-SDRAM to enter the Command Bus Training mode. When OP[0]=1 and CKE goes LOW, commands are ignored and the contents of CA[5:0] are mapped to the DQ bus. CKE must be brought HIGH before doing a MRW to clear this bit (OP[0]=0) and return to normal operation. See the Command Bus Training section for more information.
2. When set, the LPDDR4X-SDRAM will output the VREF(CA) and VREF(DQ) voltages on DQ pads. Only the "active" frequency-set-point, as defined by MR13 OP[7], will be output on the DQ pads. This function allows an external test system to measure the internal VREF levels. When the function of VRO turn on, output the VREF(DQ) value onto DQ6 and VREF(CA) value onto DQ7.
3. When OP[3]=1, the VREF circuit uses a high-current mode to improve VREF settling time.
4. MR13 OP4 RRO bit is valid only when MR0 OP0 = 1. For LPDDR4X devices with MR0 OP0 = 0, MR4 OP[2:0] bits are not dependent on MR13 OP4.
5. When OP[4] = 0, only 001<sub>b</sub> and 010<sub>b</sub> in MR4 OP[2:0] are disabled. LPDDR4X devices must report 011<sub>b</sub> instead of 001<sub>b</sub> or 010<sub>b</sub> in this case. Controller should follow the refresh mode reported by MR4 OP[2:0], regardless of RRO setting. TCSR function does not depend on RRO setting.
6. When enabled (OP[5]=0<sub>b</sub>) data masking is enabled for the device. When disabled (OP[5]= 1<sub>b</sub>), masked write command is illegal. See LPDDR4X Data Mask (DM) and Data Bus Inversion (DBI<sub>dc</sub>) Function.
7. FSP-WR determines which frequency-set-point registers are accessed with MRW commands for the following functions such as VREF(CA) Setting, VREF(CA) Range, VREF(DQ) Setting, VREF(DQ) Range. For more information, refer to 7.4.29 Frequency Set Point section.
8. FSP-OP determines which frequency-set-point register values are currently used to specify device operation for the following functions such as VREF(CA) Setting, VREF(CA) Range, VREF(DQ) Setting, VREF(DQ) Range. For more information, refer to 7.4.29 Frequency Set Point section.



### 7.3.15 MR14 Register Information (MA[5:0] = 0EH)

OP[7]	OP[6]	OP[5]	OP[4]	OP[3]	OP[2]	OP[1]	OP[0]
RFU	VR(dq)	VREF(DQ)					

Function	Type	Operand	Data	Notes
VREF(DQ) (VREF(DQ) Setting)	Read/Write	OP[5:0]	<b>000000<sub>b</sub>:</b> -- Thru -- <b>110010<sub>b</sub>: See table below</b> <b>All Others: Reserved</b>	1, 2, 3, 5, 6
VR(dq) (VREF(DQ) Range)		OP[6]	<b>0<sub>b</sub>:</b> VREF(DQ) Range[0] enabled <b>1<sub>b</sub>:</b> VREF(DQ) Range[1] enabled (default)	1, 2, 4, 5, 6

#### Notes:

1. This register controls the VREF(DQ) levels for Frequency-Set-Point[1:0]. Values from either VR(dq)[0] or VR(dq)[1] may be selected by setting OP[6] appropriately.
2. A read (MRR) to this register places the contents of OP[7:0] on DQ[7:0]. Any RFU bits and unused DQ's shall be set to '0'. See the section on MRR Operation.
3. A write to OP[5:0] sets the internal VREF(DQ) level for FSP[0] when MR13 OP[6]= 0<sub>b</sub>, or sets FSP[1] when MR13 OP[6]=1<sub>b</sub>. The time required for VREF(DQ) to reach the set level depends on the step size from the current level to the new level. See the section on VREF(DQ) training for more information.
4. A write to OP[6] switches the LPDDR4X-SDRAM between two internal VREF(DQ) ranges. The range (Range[0] or Range[1]) must be selected when setting the VREF(DQ) register. The value, once set, will be retained until over written, or until the next power-on or RESET event.
5. There are two physical registers assigned to each bit of this MR parameter, designated set point 0 and set point 1. Only the registers for the set point determined by the state of the FSP-WR bit (MR13 OP[6]) will be written to with an MRW command to this MR address, or read from with an MRR command to this address.
6. There are two physical registers assigned to each bit of this MR parameter, designated set point 0 and set point 1. The device will operate only according to the values stored in the registers for the active set point, i.e., the set point determined by the state of the FSP-OP bit (MR13 OP[7]). The values in the registers for the inactive set point will be ignored by the device, and may be changed without affecting device operation.



Table 11 - VREF Settings for Range[0] and Range[1]

Function	Operand	Range[0] Values (% of VDDQ)		Range[1] Values (% of VDDQ)		Notes
VREF Settings for MR14	OP[5:0]	000000 <sub>b</sub> : 15.0%	011010 <sub>b</sub> : 30.5%	000000 <sub>b</sub> : 32.9%	011010 <sub>b</sub> : 48.5%	1, 2, 3
		000001 <sub>b</sub> : 15.6%	011011 <sub>b</sub> : 31.1%	000001 <sub>b</sub> : 33.5%	011011 <sub>b</sub> : 49.1%	
		000010 <sub>b</sub> : 16.2%	011100 <sub>b</sub> : 31.7%	000010 <sub>b</sub> : 34.1%	011100 <sub>b</sub> : 49.7%	
		000011 <sub>b</sub> : 16.8%	011101 <sub>b</sub> : 32.3%	000011 <sub>b</sub> : 34.7%	011101 <sub>b</sub> : 50.3% (Default)	
		000100 <sub>b</sub> : 17.4%	011110 <sub>b</sub> : 32.9%	000100 <sub>b</sub> : 35.3%	011110 <sub>b</sub> : 50.9%	
		000101 <sub>b</sub> : 18.0%	011111 <sub>b</sub> : 33.5%	000101 <sub>b</sub> : 35.9%	011111 <sub>b</sub> : 51.5%	
		000110 <sub>b</sub> : 18.6%	100000 <sub>b</sub> : 34.1%	000110 <sub>b</sub> : 36.5%	100000 <sub>b</sub> : 52.1%	
		000111 <sub>b</sub> : 19.2%	100001 <sub>b</sub> : 34.7%	000111 <sub>b</sub> : 37.1%	100001 <sub>b</sub> : 52.7%	
		001000 <sub>b</sub> : 19.8%	100010 <sub>b</sub> : 35.3%	001000 <sub>b</sub> : 37.7%	100010 <sub>b</sub> : 53.3%	
		001001 <sub>b</sub> : 20.4%	100011 <sub>b</sub> : 35.9%	001001 <sub>b</sub> : 38.3%	100011 <sub>b</sub> : 53.9%	
		001010 <sub>b</sub> : 21.0%	100100 <sub>b</sub> : 36.5%	001010 <sub>b</sub> : 38.9%	100100 <sub>b</sub> : 54.5%	
		001011 <sub>b</sub> : 21.6%	100101 <sub>b</sub> : 37.1%	001011 <sub>b</sub> : 39.5%	100101 <sub>b</sub> : 55.1%	
		001100 <sub>b</sub> : 22.2%	100110 <sub>b</sub> : 37.7%	001100 <sub>b</sub> : 40.1%	100110 <sub>b</sub> : 55.7%	
		001101 <sub>b</sub> : 22.8%	100111 <sub>b</sub> : 38.3%	001101 <sub>b</sub> : 40.7%	100111 <sub>b</sub> : 56.3%	
		001110 <sub>b</sub> : 23.4%	101000 <sub>b</sub> : 38.9%	001110 <sub>b</sub> : 41.3%	101000 <sub>b</sub> : 56.9%	
		001111 <sub>b</sub> : 24.0%	101001 <sub>b</sub> : 39.5%	001111 <sub>b</sub> : 41.9%	101001 <sub>b</sub> : 57.5%	
		010000 <sub>b</sub> : 24.6%	101010 <sub>b</sub> : 40.1%	010000 <sub>b</sub> : 42.5%	101010 <sub>b</sub> : 58.1%	
		010001 <sub>b</sub> : 25.1%	101011 <sub>b</sub> : 40.7%	010001 <sub>b</sub> : 43.1%	101011 <sub>b</sub> : 58.7%	
		010010 <sub>b</sub> : 25.7%	101100 <sub>b</sub> : 41.3%	010010 <sub>b</sub> : 43.7%	101100 <sub>b</sub> : 59.3%	
		010011 <sub>b</sub> : 26.3%	101101 <sub>b</sub> : 41.9%	010011 <sub>b</sub> : 44.3%	101101 <sub>b</sub> : 59.9%	
		010100 <sub>b</sub> : 26.9%	101110 <sub>b</sub> : 42.5%	010100 <sub>b</sub> : 44.9%	101110 <sub>b</sub> : 60.5%	
		010101 <sub>b</sub> : 27.5%	101111 <sub>b</sub> : 43.1%	010101 <sub>b</sub> : 45.5%	101111 <sub>b</sub> : 61.1%	
		010110 <sub>b</sub> : 28.1%	110000 <sub>b</sub> : 43.7%	010110 <sub>b</sub> : 46.1%	110000 <sub>b</sub> : 61.7%	
		010111 <sub>b</sub> : 28.7%	110001 <sub>b</sub> : 44.3%	010111 <sub>b</sub> : 46.7%	110001 <sub>b</sub> : 62.3%	
011000 <sub>b</sub> : 29.3%	110010 <sub>b</sub> : 44.9%	011000 <sub>b</sub> : 47.3%	110010 <sub>b</sub> : 62.9%			
011001 <sub>b</sub> : 29.9%	All Others: Reserved	011001 <sub>b</sub> : 47.9%	All Others: Reserved			

**Notes:**

1. These values may be used for MR14 OP[5:0] to set the VREF(DQ) levels in the LPDDR4X-SDRAM.
2. The range may be selected in the MR14 register by setting OP[6] appropriately.
3. The MR14 registers represents either FSP[0] or FSP[1]. Two frequency-set-points each for CA and DQ are provided to allow for faster switching between terminated and un-terminated operation, or between different high frequency setting which may use different terminations values.



### 7.3.16 MR15 Register Information (MA[5:0] = 0FH)

OP[7]	OP[6]	OP[5]	OP[4]	OP[3]	OP[2]	OP[1]	OP[0]
Lower-Byte Invert Register for DQ Calibration							

Function	Type	Operand	Data	Notes
Lower-Byte Invert for DQ Calibration	Write-only	OP[7:0]	<p>The following values may be written for any operand OP[7:0], and will be applied to the corresponding DQ locations DQ[7:0] within a byte lane:</p> <p><b>0<sub>b</sub></b>: Do not invert</p> <p><b>1<sub>b</sub></b>: Invert the DQ Calibration patterns in MR32 and MR40</p> <p>Default value for OP[7:0]=55H</p>	1, 2, 3

**Notes:**

1. This register will invert the DQ Calibration pattern found in MR32 and MR40 for any single DQ, or any combination of DQ's. Example: If MR15 OP[7:0]=00010101<sub>b</sub>, then the DQ Calibration patterns transmitted on DQ[7,6,5,3,1] will not be inverted, but the DQ Calibration patterns transmitted on DQ[4,2,0] will be inverted.
2. DMI[0] is not inverted, and always transmits the "true" data contained in MR32/MR40.
3. No Data Bus Inversion (DBI) function is enacted during DQ Read Calibration, even if DBI is enabled in MR3-OP[6].

**Table 12 - MR15 Invert Register Pin Mapping**

PIN	DQ[7]	DQ [6]	DQ [5]	DQ [4]	DMI0	DQ [3]	DQ [2]	DQ [1]	DQ [0]
MR15	OP[7]	OP[6]	OP[5]	OP[4]	Non-inverted	OP[3]	OP[2]	OP[1]	OP[0]





## 7.3.17 MR16 Register Information (MA[5:0] = 10H)

OP[7]	OP[6]	OP[5]	OP[4]	OP[3]	OP[2]	OP[1]	OP[0]
PASR Bank Mask							

Function	Type	Operand	Data	Notes
Bank[7:0] Mask	Write-only	OP[7:0]	<b>0b</b> : Bank Refresh enabled (default) : Unmasked <b>1b</b> : Bank Refresh disabled : Masked	1

OP[n]	Bank Mask	8-Bank SDRAM
0	XXXXXXXX1	Bank 0
1	XXXXXXXX1X	Bank 1
2	XXXXX1XX	Bank 2
3	XXXX1XXX	Bank 3
4	XXX1XXXX	Bank 4
5	XX1XXXXX	Bank 5
6	X1XXXXXX	Bank 6
7	1XXXXXXX	Bank 7

**Notes:**

- When a mask bit is asserted (OP[n]=1), refresh to that bank is disabled.
- PASR bank-masking is on a per-channel basis. The two channels on the die may have different bank masking in dual channel devices.

## 7.3.18 MR17 Register Information (MA[5:0] = 11H)

OP[7]	OP[6]	OP[5]	OP[4]	OP[3]	OP[2]	OP[1]	OP[0]
PASR Segment Mask							

Function	Type	Operand	Data	Notes
PASR Segment Mask	Write-only	OP[7:0]	<b>0b</b> : Segment Refresh enabled (default) <b>1b</b> : Segment Refresh disabled	

Segment	OP[n]	Segment Mask	Per Channel
			R[13:11]
0	0	XXXXXXXX1	000b
1	1	XXXXXXXX1X	001b
2	2	XXXXX1XX	010b
3	3	XXXX1XXX	011b
4	4	XXX1XXXX	100b
5	5	XX1XXXXX	101b
6	6	X1XXXXXX	110b
7	7	1XXXXXXX	111b

**Notes:**

- This table indicates the range of row addresses in each masked segment. "X" is don't care for a particular segment.
- PASR segment-masking is on a per-channel basis. The two channels on the die may have different segment masking in dual channel devices.



### 7.3.19 MR18 Register Information (MA[5:0] = 12H)

OP[7]	OP[6]	OP[5]	OP[4]	OP[3]	OP[2]	OP[1]	OP[0]
DQS Oscillator Count - LSB							

Function	Type	Operand	Data	Notes
DQS Oscillator (WR Training DQS Oscillator)	Read-only	OP[7:0]	0-255 LSB DRAM DQS Oscillator Count	1, 2, 3

#### Notes:

- MR18 reports the LSB bits of the DRAM DQS Oscillator count. The DRAM DQS Oscillator count value is used to train DQS to the DQ data valid window. The value reported by the DRAM in this mode register can be used by the memory controller to periodically adjust the phase of DQS relative to DQ.
- Both MR18 and MR19 must be read (MRR) and combined to get the value of the DQS Oscillator count.
- A new MPC [Start DQS Oscillator] should be issued to reset the contents of MR18/MR19.

### 7.3.20 MR19 Register Information (MA[5:0] = 13H)

OP[7]	OP[6]	OP[5]	OP[4]	OP[3]	OP[2]	OP[1]	OP[0]
DQS Oscillator Count - MSB							

Function	Type	Operand	Data	Notes
DQS Oscillator (WR Training DQS Oscillator)	Read-only	OP[7:0]	0-255 MSB DRAM DQS Oscillator Count	1, 2, 3

#### Notes:

- MR19 reports the MSB bits of the DRAM DQS Oscillator count. The DRAM DQS Oscillator count value is used to train DQS to the DQ data valid window. The value reported by the DRAM in this mode register can be used by the memory controller to periodically adjust the phase of DQS relative to DQ.
- Both MR18 and MR19 must be read (MRR) and combined to get the value of the DQS Oscillator count.
- A new MPC [Start DQS Oscillator] should be issued to reset the contents of MR18/MR19.

### 7.3.21 MR20 Register Information (MA[5:0] = 14H)

OP[7]	OP[6]	OP[5]	OP[4]	OP[3]	OP[2]	OP[1]	OP[0]
Upper-Byte Invert Register for DQ Calibration							

Function	Type	Operand	Data	Notes
Upper-Byte Invert for DQ Calibration	Write-only	OP[7:0]	The following values may be written for any operand OP[7:0], and will be applied to the corresponding DQ locations DQ[15:8] within a byte lane: <b>0b</b> : Do not invert <b>1b</b> : Invert the DQ Calibration patterns in MR32 and MR40 Default value for OP[7:0] = 55H	1, 2

#### Notes:

- This register will invert the DQ Calibration pattern found in MR32 and MR40 for any single DQ, or any combination of DQ's. Example: If MR20 OP[7:0]=00010101<sub>b</sub>, then the DQ Calibration patterns transmitted on DQ[15,14,13,11,9] will not be inverted, but the DQ Calibration patterns transmitted on DQ[12,10,8] will be inverted.
- DMI[1] is not inverted, and always transmits the "true" data contained in MR32/MR40.
- No Data Bus Inversion (DBI) function is enacted during DQ Read Calibration, even if DBI is enabled in MR3-OP[6].

**Table 13 - MR20 Invert Register Pin Mapping**

PIN	DQ[15]	DQ [14]	DQ [13]	DQ [12]	DMI1	DQ [11]	DQ [10]	DQ [9]	DQ [8]
MR20	OP[7]	OP[6]	OP[5]	OP[4]	Non-inverted	OP[3]	OP[2]	OP[1]	OP[0]

### 7.3.22 MR21 Register (Reserved) (MA[5:0] = 15H)



## 7.3.23 MR22 Register Information (MA[5:0] = 16H)

OP[7]	OP[6]	OP[5]	OP[4]	OP[3]	OP[2]	OP[1]	OP[0]
Reserved		ODTD-CA	ODTE-CS	ODTE-CK	SOC ODT		

Function	Type	Operand	Data	Notes
SoC ODT (Controller ODT Value for VOH calibration)	Write-only	OP[2:0]	<b>000<sub>b</sub></b> : Disable (Default) <b>001<sub>b</sub></b> : RZQ/1 (illegal if MR3 OP[0] = 0 <sub>b</sub> ) <b>010<sub>b</sub></b> : RZQ/2 <b>011<sub>b</sub></b> : RZQ/3 (illegal if MR3 OP[0] = 0 <sub>b</sub> ) <b>100<sub>b</sub></b> : RZQ/4 <b>101<sub>b</sub></b> : RZQ/5 (illegal if MR3 OP[0] = 0 <sub>b</sub> ) <b>110<sub>b</sub></b> : RZQ/6 (illegal if MR3 OP[0] = 0 <sub>b</sub> ) <b>111<sub>b</sub></b> : Reserved	1, 2, 3
ODTE-CK (CK ODT enabled for nonterminating rank)		OP[3]	ODT bond PAD is ignored <b>0<sub>b</sub></b> : ODT-CK Enabled (Default) <b>1<sub>b</sub></b> : ODT-CK Disabled	2, 3, 4
ODTE-CS (CS ODT enable for nonterminating rank)		OP[4]	ODT bond PAD is ignored <b>0<sub>b</sub></b> : ODT-CS Enabled (Default) <b>1<sub>b</sub></b> : ODT-CS Disabled	2, 3, 4
ODTD-CA (CA ODT termination disable)		OP[5]	ODT bond PAD is ignored <b>0<sub>b</sub></b> : ODT-CA Enabled (Default) <b>1<sub>b</sub></b> : ODT-CA Disabled	2, 3, 4

**Notes:**

- All values are "typical".
- There are two physical registers assigned to each bit of this MR parameter, designated set point 0 and set point 1. Only the registers for the set point determined by the state of the FSP-WR bit (MR13 OP[6]) will be written to with an MRW command to this MR address, or read from with an MRR command to this address.
- There are two physical registers assigned to each bit of this MR parameter, designated set point 0 and set point 1. The device will operate only according to the values stored in the registers for the active set point, i.e., the set point determined by the state of the FSP-OP bit (MR13 OP[7]). The values in the registers for the inactive set point will be ignored by the device, and may be changed without affecting device operation.
- The ODT\_CA pad is ignored by LPDDR4X devices. The ODT\_CA pad shall be connected to either VDD2 or VSS. CA/ CS/ CK ODT is fully controlled through MR11 and MR22. Before enabling CA termination via MR11, all ranks should have appropriate MR22 termination settings programmed.



### 7.3.24 MR23 Register Information (MA[5:0] = 17H)

OP[7]	OP[6]	OP[5]	OP[4]	OP[3]	OP[2]	OP[1]	OP[0]
DQS interval timer run time setting							

Function	Type	Operand	Data	Notes
DQS interval timer run time	Write-only	OP[7:0]	<b>00000000<sub>b</sub></b> : DQS interval timer stop via MPC Command (Default) <b>00000001<sub>b</sub></b> : DQS timer stops automatically at 16th clocks after timer start <b>00000010<sub>b</sub></b> : DQS timer stops automatically at 32nd clocks after timer start <b>00000011<sub>b</sub></b> : DQS timer stops automatically at 48th clocks after timer start <b>00000100<sub>b</sub></b> : DQS timer stops automatically at 64th clocks after timer start ----- Thru ----- <b>00111111<sub>b</sub></b> : DQS timer stops automatically at (63x16)th clocks after timer start <b>01XXXXXX<sub>b</sub></b> : DQS timer stops automatically at 2048th clocks after timer start <b>10XXXXXX<sub>b</sub></b> : DQS timer stops automatically at 4096th clocks after timer start <b>11XXXXXX<sub>b</sub></b> : DQS timer stops automatically at 8192nd clocks after timer start	1, 2

#### Notes:

- MPC command with OP[6:0]=1001101<sub>b</sub> (Stop DQS Interval Oscillator) stops DQS interval timer in case of MR23 OP[7:0] = 00000000<sub>b</sub>.
- MPC command with OP[6:0]=1001101<sub>b</sub> (Stop DQS Interval Oscillator) is illegal with non-zero values in MR23 OP[7:0].

### 7.3.25 MR24 Register Information (MA[5:0] = 18H)

OP[7]	OP[6]	OP[5]	OP[4]	OP[3]	OP[2]	OP[1]	OP[0]
TRR Mode	TRR Mode BAn			Unlimited MAC	MAC Value		

Function	Type	Operand	Data	Notes
MAC Value	Read-only	OP[2:0]	<b>000<sub>b</sub></b> : Unknown when bit OP3=0 (Note 1) Unlimited when bit OP3=1 (Note 2) <b>001<sub>b</sub></b> : 700K <b>010<sub>b</sub></b> : 600K <b>011<sub>b</sub></b> : 500K <b>100<sub>b</sub></b> : 400K <b>101<sub>b</sub></b> : 300K <b>110<sub>b</sub></b> : 200K <b>111<sub>b</sub></b> : Reserved	
Unlimited MAC	Read-only	OP[3]	<b>0<sub>b</sub></b> : OP[2:0] define MAC value <b>1<sub>b</sub></b> : Unlimited MAC value (Note 2, Note 3)	
TRR Mode BAn	Write-only	OP[6:4]	<b>000<sub>b</sub></b> : Bank 0 <b>001<sub>b</sub></b> : Bank 1 <b>010<sub>b</sub></b> : Bank 2 <b>011<sub>b</sub></b> : Bank 3 <b>100<sub>b</sub></b> : Bank 4 <b>101<sub>b</sub></b> : Bank 5 <b>110<sub>b</sub></b> : Bank 6 <b>111<sub>b</sub></b> : Bank 7	
TRR Mode	Write-only	OP[7]	<b>0<sub>b</sub></b> : Disabled (default) <b>1<sub>b</sub></b> : Enabled	

#### Notes:

- Unknown means that the device is not tested for tMAC and pass/fail value in unknown.
- There is no restriction to number of activates.
- MR24 OP [2:0] is set to zero.



### 7.3.26 MR25 Register Information (MA[5:0] = 19H)

Mode Register 25 contains one bit of readout per bank indicating that at least one resource is available for Post Package Repair programming.

OP[7]	OP[6]	OP[5]	OP[4]	OP[3]	OP[2]	OP[1]	OP[0]
Bank 7	Bank 6	Bank 5	Bank 4	Bank 3	Bank 2	Bank 1	Bank 0

Function	Type	Operand	Data	Note
PPR Resource	Read-only	OP[7:0]	<b>0<sub>b</sub></b> : PPR Resource is not available <b>1<sub>b</sub></b> : PPR Resource is available	

### 7.3.27 MR26~29 (Reserved) (MA[5:0] = 1AH-1DH)

### 7.3.28 MR30 Register Information (MA[5:0] = 1EH)

OP[7]	OP[6]	OP[5]	OP[4]	OP[3]	OP[2]	OP[1]	OP[0]
Valid 0 or 1							

Function	Type	Operand	Data	Note
SDRAM will ignore	Write-only	OP[7:0]	Don't care	1

**Note:**

- This register is reserved for testing purposes. The logical data values written to OP[7:0] shall have no effect on SDRAM operation, however timings need to be observed as for any other MR access command.

### 7.3.29 MR31 (Reserved) (MA[5:0] = 1FH)

### 7.3.30 MR32 Register Information (MA[5:0] = 20H)

OP[7]	OP[6]	OP[5]	OP[4]	OP[3]	OP[2]	OP[1]	OP[0]
DQ Calibration Pattern "A" (default = 5AH)							

Function	Type	Operand	Data	Note
Return DQ Calibration Pattern MR32 + MR40	Write-only	OP[7:0]	<b>X<sub>b</sub></b> : An MPC command with OP[6:0]= 100011 <sub>b</sub> causes the device to return the DQ Calibration Pattern contained in this register and (followed by) the contents of MR40. A default pattern "5AH" is loaded at power-up or RESET, or the pattern may be overwritten with a MRW to this register. The contents of MR15 and MR20 will invert the data pattern for a given DQ (See MR15 for more information)	

### 7.3.31 MR33~38 (Reserved) (MA[5:0] = 21H-26H)



### 7.3.32 MR39 Register Information (MA[5:0] = 27H)

OP[7]	OP[6]	OP[5]	OP[4]	OP[3]	OP[2]	OP[1]	OP[0]
Valid 0 or 1							

Function	Type	Operand	Data	Note
SDRAM will ignore	Write-only	OP[7:0]	Don't care	1

**Note:**

1. This register is reserved for testing purposes. The logical data values written to OP[7:0] shall have no effect on SDRAM operation, however timings need to be observed as for any other MR access command.

### 7.3.33 MR40 Register Information (MA[5:0] = 28H)

OP[7]	OP[6]	OP[5]	OP[4]	OP[3]	OP[2]	OP[1]	OP[0]
DQ Calibration Pattern "B" (default = 3CH)							

Function	Type	Operand	Data	Notes
Return DQ Calibration Pattern MR32 + MR40	Write-only	OP[7:0]	<b>Xb:</b> A default pattern "3CH" is loaded at power up or RESET, or the pattern may be overwritten with a MRW to this register. See MR32 for more information	1, 2, 3

**Notes:**

1. The pattern contained in MR40 is concatenated to the end of MR32 and transmitted on DQ[15:0] and DMI[1:0] when DQ Read Calibration is initiated via a MPC command. The pattern transmitted serially on each data lane, organized "little endian" such that the low-order bit in a byte is transmitted first. If the data pattern in MR40 is 27H, then the first bit transmitted will be a '1', followed by '1', '1', '0', '0', '1', '0', and '0'. The bit stream will be 00100111<sub>b</sub>.
2. MR15 and MR20 may be used to invert the MR32/MR40 data patterns on the DQ pins. See MR15 and MR20 for more information. Data is never inverted on the DMI[1:0] pins.
3. The data pattern is not transmitted on the DMI[1:0] pins if DBI-RD is disabled via MR3-OP[6].
4. No Data Bus Inversion (DBI) function is enacted during DQ Read Calibration, even if DBI is enabled in MR3-OP[6].



## 7.4 Command Definitions and Timing Diagrams

### 7.4.1 Activate Command

The Activate command is composed of two consecutive commands, Activate-1 command and Activate-2. Activate-1 command is issued by holding CS HIGH, CA0 HIGH and CA1 LOW at the first rising edge of the clock and Activate-2 command issued by holding CS HIGH, CA0 HIGH and CA1 HIGH at the first rising edge of the clock. The bank addresses BA0, BA1 and BA2 are used to select desired bank. Row addresses are used to determine which row to activate in the selected bank. The ACTIVATE command must be applied before any READ or WRITE operation can be executed. The device can accept a READ or WRITE command at tRCD after the Activate command is issued. After a bank has been activated it must be precharged before another Activate E command can be applied to the same bank. The bank active and precharge times are defined as tRAS and tRP respectively. The minimum time interval between Activate commands to the same bank is determined by the RAS cycle time of the device (tRC). The minimum time interval between Activate commands to different banks is tRRD.

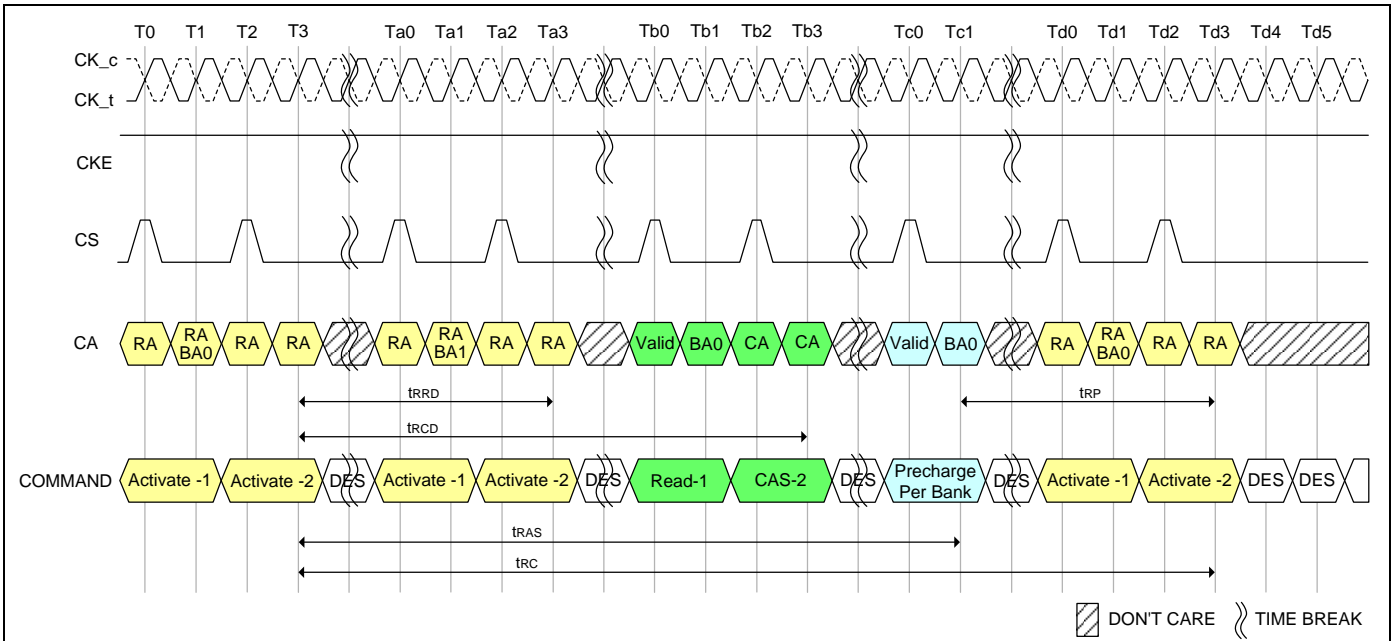

**Note:**

1. A PRECHARGE command uses tRPab timing for all bank PRECHARGE and tRPpb timing for single-bank PRECHARGE. In this figure, tRP is used to denote either all bank PRECHARGE or a single-bank PRECHARGE.

**Figure 4 - Activate Command**

#### 7.4.1.1 8-Bank Device Operation

Certain restrictions on operation of the 8-bank LPDDR4X devices must be observed. There are two rules. One rule restricts the number of sequential Activate commands that can be issued; the other provides more time for RAS precharge for a Precharge All command. The rules are as follows:

**8-bank device Sequential Bank Activation Restriction:**

No more than 4 banks may be activated (or refreshed, in the case of REFpb) in a rolling tFAW window. The number of clocks in a tFAW period is dependent upon the clock frequency, which may vary. If the clock frequency is not changed over this period, converting clocks is done by dividing tFAW [ns] by tCK [ns], and rounding up to the next integer value. As an example of the rolling window, if RU (tFAW/tCK) is 10 clocks, and an Activate command is issued in clock n, no more than three further Activate commands can be issued at or between clock n + 1 and n + 9. REFpb also counts as bank activation for purposes of tFAW. If the clock frequency is changed during the tFAW period, the rolling tFAW window may be calculated in clock cycles by adding up the time spent in each clock period. The tFAW requirement is met when the previous n clock cycles exceeds the tFAW time.

**The 8-bank device Precharge-All Allowance:**

tRP for a Precharge All command must equal tRPab, which is greater than tRPpb.



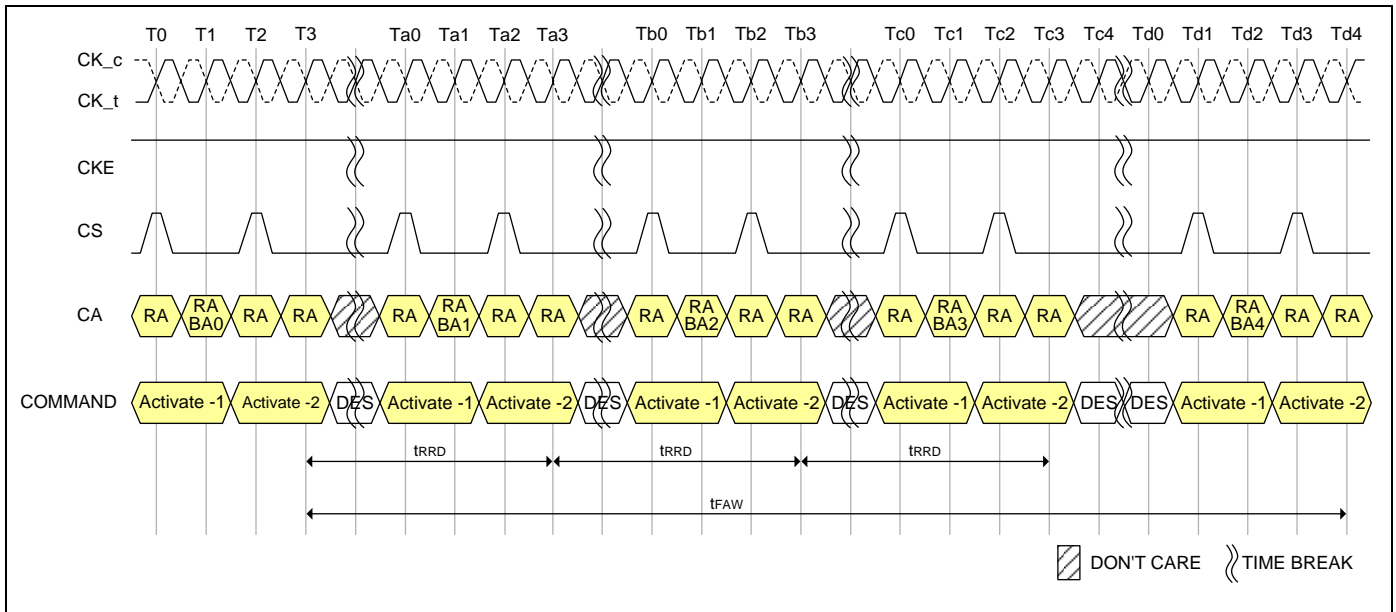

Figure 5 - tFAW Timing

7.4.2 Core Timing

Table 14 - Core AC Timing

Parameter	Symbol	Min/Max	Data Rate							Unit	
			533	1066	1600	2133	2667	3200	3733		4267
Core Parameters			533	1066	1600	2133	2667	3200	3733	4267	
ACTIVATE-to-ACTIVATE command period (same bank)	tRC	MIN	tRAS + tRPab (with all bank precharge) tRAS + tRPpb (with per bank precharge)							nS	
Minimum Self Refresh Time (Entry to Exit)	tSR	MIN	max(15nS, 3nCK)							nS	
Self Refresh exit to next valid command delay	tXSR	MIN	max(tRFCab + 7.5nS, 2nCK)							nS	
Exit Power-Down to next valid command delay	tXP	MIN	max(7.5nS, 5nCK)							nS	
CAS-to-CAS delay	tCCD	MIN	8							tCK(avg)	
Internal READ to PRECHARGE command delay	tRTP	MIN	max(7.5nS, 8nCK)							nS	
RAS-to-CAS delay	tRCD	MIN	max(18nS, 4nCK)							nS	
Row precharge time (single bank)	tRPpb	MIN	max(18nS, 4nCK)							nS	
Row precharge time (all banks)	tRPab	MIN	max(21nS, 4nCK)							nS	
Row active time	tRAS	MIN	max(42nS, 3nCK)							-	
		MAX	Min(9 * tREFI * Refresh Rate, 70.2) μS (Refresh Rate is specified by MR4, OP[2:0])								
WRITE recovery time	tWR	MIN	max(18nS, 6nCK)							nS	
WRITE-to-READ delay	tWTR	MIN	max(10nS, 8nCK)							nS	
Active bank-A to active bank-B	tRRD	MIN	Max(10nS, 4nCK)							Max(7.5ns, 4nCK)*2	nS
Precharge to Precharge Delay*1	tPPD	MIN	4							tCK	
Four-bank ACTIVATE window	tFAW	MIN	40							30*2	nS

Notes:

1. Precharge to precharge timing restriction does not apply to Auto-Precharge commands.
2. Devices supporting 4267 Mbps specification shall support these timings at lower data rates.



### 7.4.3 Read and Write Access Operations

After a bank has been activated, a read or write command can be executed. This is accomplished by asserting CKE asynchronously, with CS and CA[5:0] set to the proper state (see Command Truth Table) at a rising edge of CK.

The LPDDR4X-SDRAM provides a fast column access operation. A single Read or Write command will initiate a burst read or write operation, where data is transferred to/from the DRAM on successive clock cycles. Burst interrupts are not allowed, but the optimal burst length may be set on the fly (see command truth table).

### 7.4.4 Read Preamble and Postamble

The DQS strobe for the LPDDR4X-SDRAM requires a pre-amble prior to the first latching edge (the rising edge of DQS\_t with DATA “valid”), and it requires a post-amble after the last latching edge. The pre-amble and post-amble lengths are set via mode register writes (MRW).

For READ operations the pre-amble is 2\*tCK, but the pre-amble is static (no-toggle) or toggling, selectable via mode register.

LPDDR4X will have a DQS Read post-ample of 0.5\*tCK (or extended to 1.5\*tCK). Standard DQS postamble will be 0.5\*tCK driven by the DRAM for Reads. A mode register setting instructs the DRAM to drive an additional (extended) one cycle DQS Read post-ample. The drawings below show examples of DQS Read post-ample for both standard (tRPST) and extended (tRPSTE) post-ample operation.

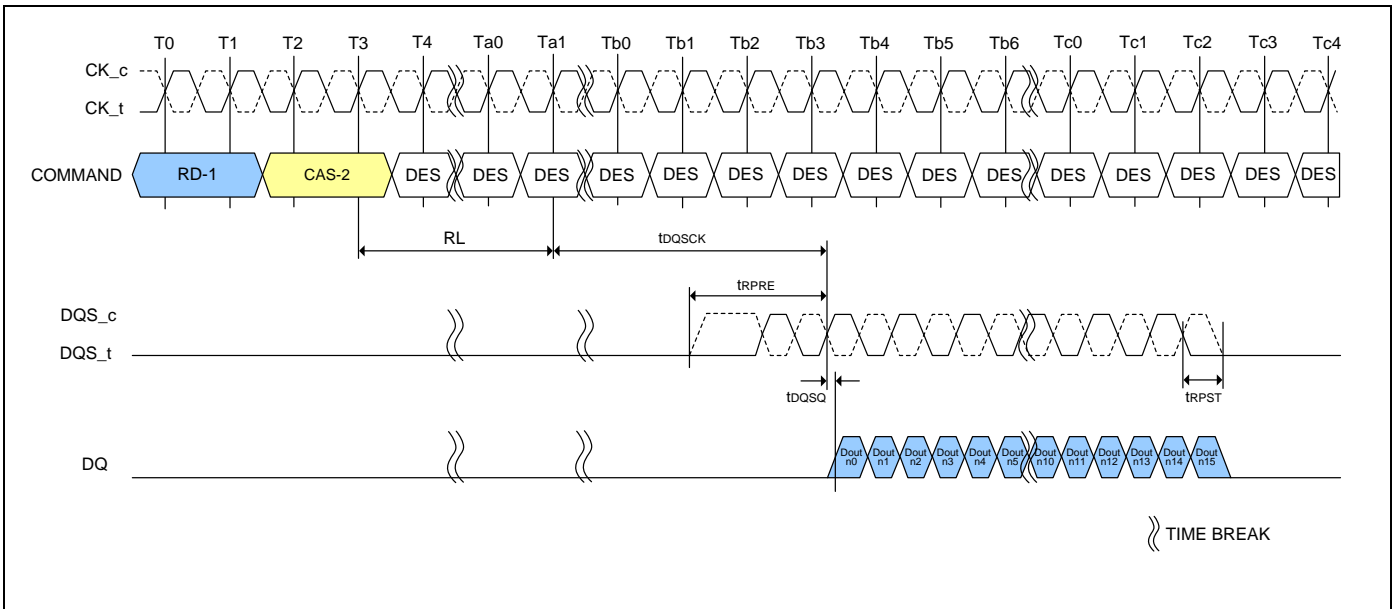

**Notes:**

1. BL = 16, Preamble = Toggling, Postamble = 0.5nCK.
2. DQS and DQ terminated VSSQ.
3. DQS\_t/DQS\_c is “don't care” prior to the start of tRPRE.

No transition of DQS is implied, as DQS\_t/DQS\_c can be HIGH, LOW, or HI-Z prior to tRPRE.

**Figure 6 - DQS Read Preamble and Postamble: Toggling Preamble and 0.5nCK Postamble**

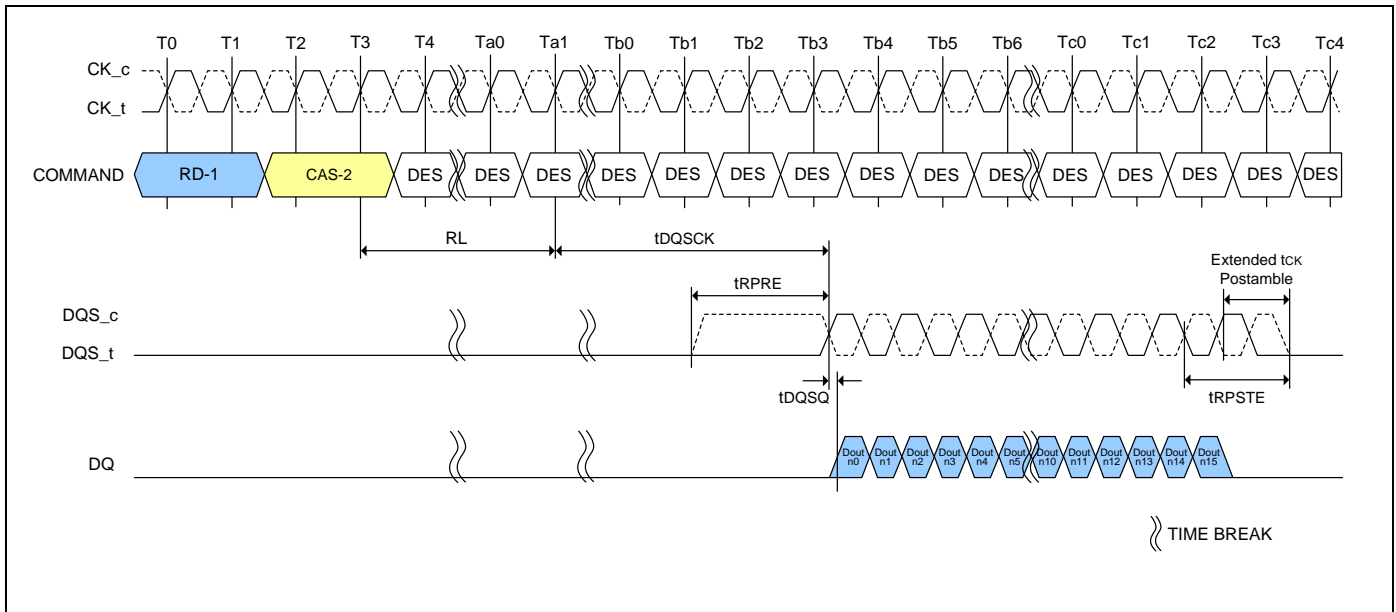

**Notes:**

1. BL = 16, Preamble = Static, Postamble = 1.5nCK (Extended).
2. DQS and DQ terminated VSSQ.
3. DQS\_t/DQS\_c is "don't care" prior to the start of tRPRE.  
No transition of DQS is implied, as DQS\_t/DQS\_c can be HIGH, LOW, or HI-Z prior to tRPRE.

**Figure 7 - DQS Read Preamble and Postamble: Static Preamble and 1.5nCK Postamble**

**7.4.5 Burst Read Operation**

A burst Read command is initiated with CS, and CA[5:0] asserted to the proper state at the rising edge of CK, as defined by the Command Truth Table. The command address bus inputs determine the starting column address for the burst. The two low-order address bits are not transmitted on the CA bus and are implied to be "0", so that the starting burst address is always a multiple of four (ex. 0x0, 0x4, 0x8, 0xC). The read latency (RL) is defined from the last rising edge of the clock that completes a read command (Ex: the second rising edge of the CAS-2 command) to the rising edge of the clock from which the tDQSCK delay is measured. The first valid data is available  $RL * tCK + tDQSCK + tDQSQ$  after the rising edge of Clock that completes a read command. The data strobe output is driven tRPRE before the first valid rising strobe edge. The first data-bit of the burst is synchronized with the first valid (i.e. post-preamble) rising edge of the data strobe. Each subsequent data out appears on each DQ pin, edge-aligned with the data strobe. At the end of a burst the DQS signals are driven for another half cycle post-amble, or for a 1.5-cycle postamble if the programmable post-amble bit is set in the mode register. The RL is programmed in the mode registers. Pin timings for the data strobe are measured relative to the cross-point of DQS\_t and DQS\_c.

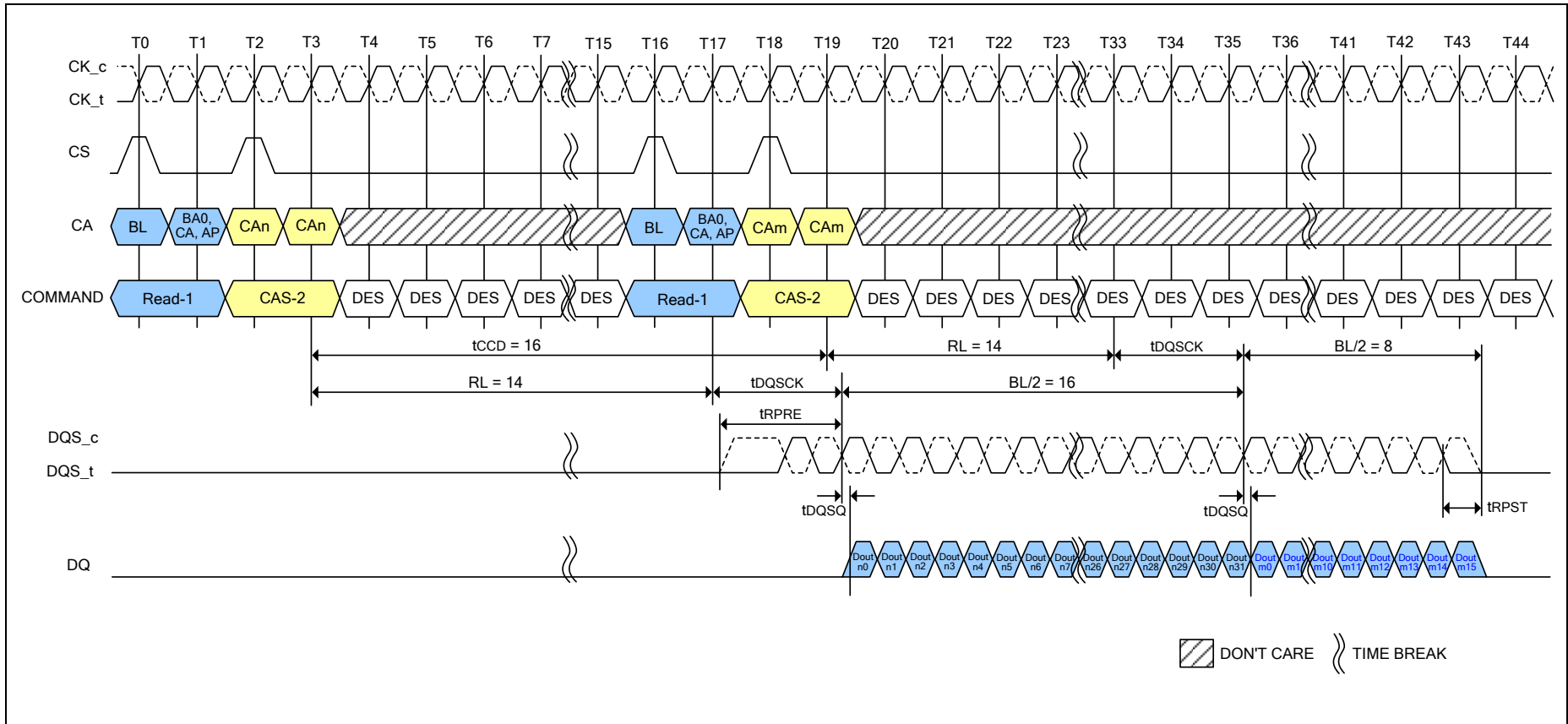

**Notes:**

1. BL = 32 for column n, BL = 16 for column m, RL = 14, Preamble = Toggle, Postamble = 0.5nCK, DQ/DQS: VSSQ termination.
2. Dout n/m = data-out from column n and column m.
3. DES commands are shown for ease of illustration; other commands may be valid at these times.

**Figure 8 - Burst Read Timing**

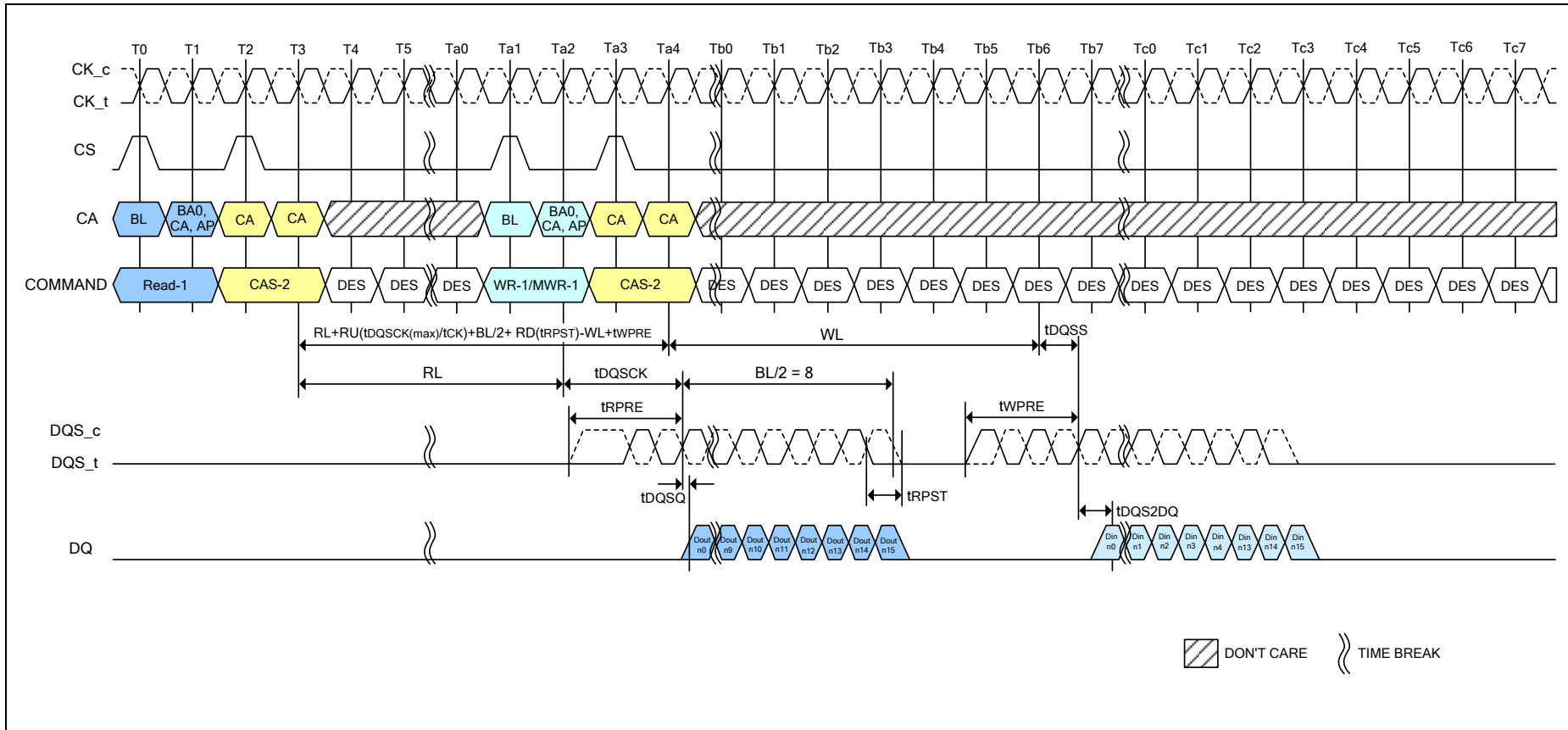

- Notes:**
1. BL=16, Read Preamble = Toggle, Read Postamble = 0.5nCK, Write Preamble = 2nCK, Write Postamble = 0.5nCK, DQ/DQS: VSSQ termination.
  2. Dout n = data-out from column n and Din n = data-in to column n.
  3. DES commands are shown for ease of illustration; other commands may be valid at these times.

**Figure 9 - Burst Read followed by Burst Write or Burst Mask Write**

The minimum time from a Burst Read command to a Write or MASK WRITE command is defined by the read latency (RL) and the burst length (BL). Minimum READ-to-WRITE or MASK WRITE latency is  $RL+RU(tDQSK(max)/tCK)+BL/2+ RD(trPST)-WL+tWPRE$ .

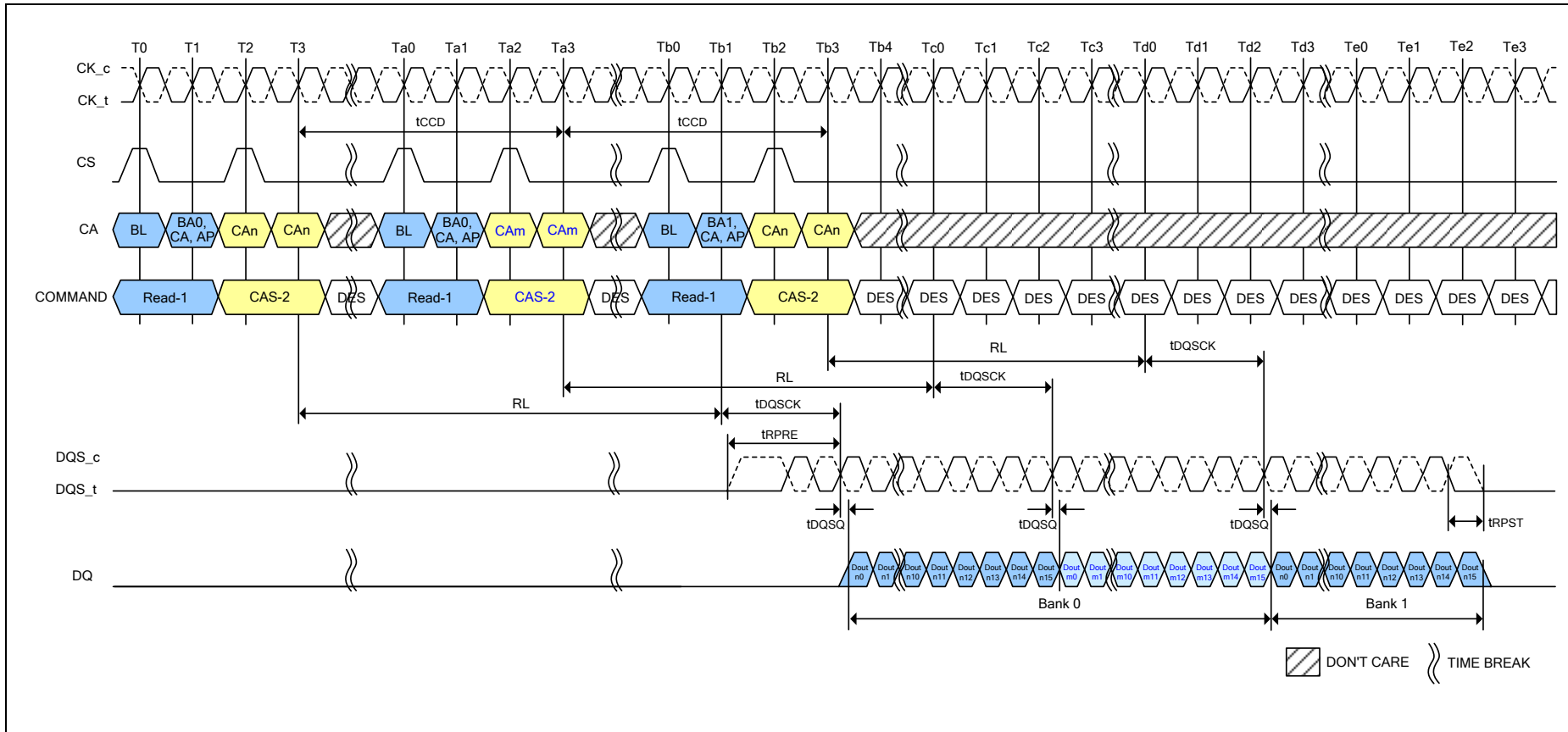

**Notes:**

1. BL = 16, tCCD = 8, Preamble = Toggle, Postamble = 0.5nCK, DQ/DQS: VSSQ termination.
2. Dout n/m = data-out from column n and column m.
3. DES commands are shown for ease of illustration; other commands may be valid at these times.

**Figure 10 - Seamless Burst Read**

The seamless Burst READ operation is supported by placing a READ command at every tCCD(Min) interval for BL16 (or every 2 x tCCD(Min) for BL32). The seamless Burst READ can access any open bank.



### 7.4.6 Read Timing

The read timing is shown in the figure below.

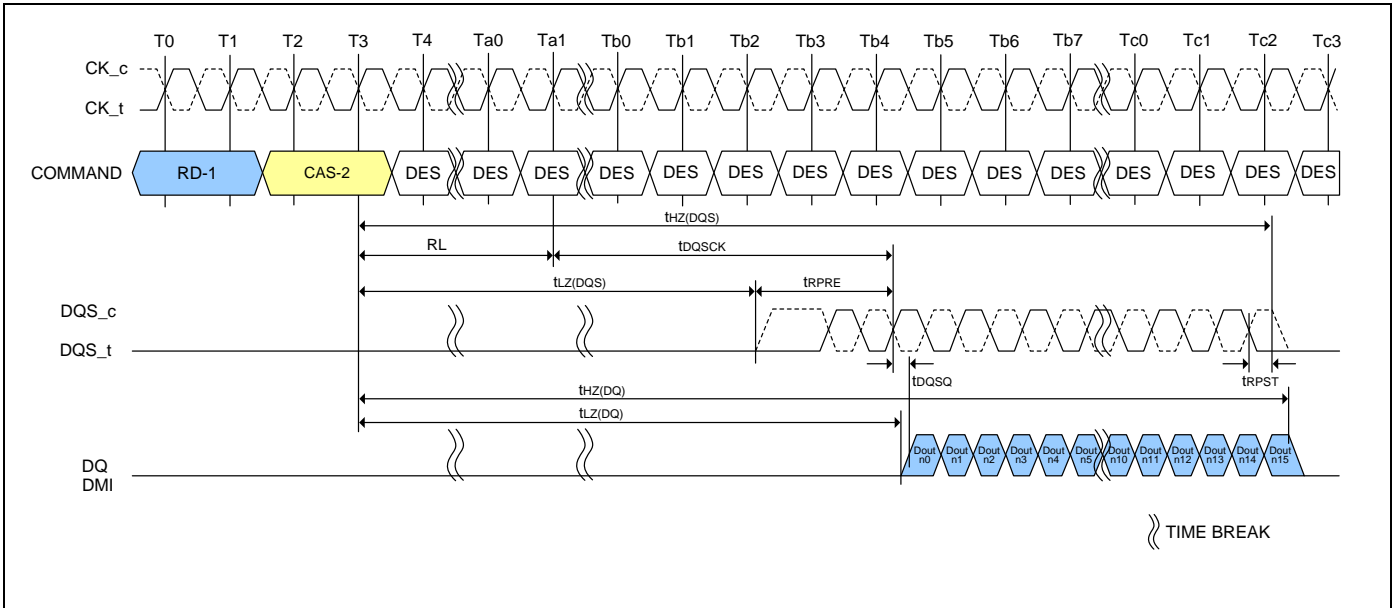

**Notes:**

1. BL = 16, Preamble = Toggling, Postamble = 0.5nCK.
2. DQS, DQ and DMI terminated VSSQ.
3. Output driver does not turn on before an end point of tLZ(DQS) and tLZ(DQ).
4. Output driver does not turn off before an end point of tHZ(DQS) and tHZ(DQ).

**Figure 11 - Read Timing**

### 7.4.7 tLZ(DQS), tLZ(DQ), tHZ(DQS), tHZ(DQ) Calculation

tHZ and tLZ transitions occur in the same time window as valid data transitions. These parameters are referenced to a specific voltage level that specifies when the device output is no longer driving tHZ(DQS) and tHZ(DQ), or begins driving tLZ(DQS), tLZ(DQ).

This section shows a method to calculate the point when the device is no longer driving tHZ(DQS) and tHZ(DQ), or begins driving tLZ(DQS), tLZ(DQ), by measuring the signal at two different voltages. The actual voltage measurement points are not critical as long as the calculation is consistent. The parameters tLZ(DQS), tLZ(DQ), tHZ(DQS), and tHZ(DQ) are defined as single ended.





### 7.4.7.1 tLZ(DQS) and tHZ(DQS) Calculation for ATE (Automatic Test Equipment)

CK\_t - CK\_c crossing at 2nd CAS-2 of Read Command

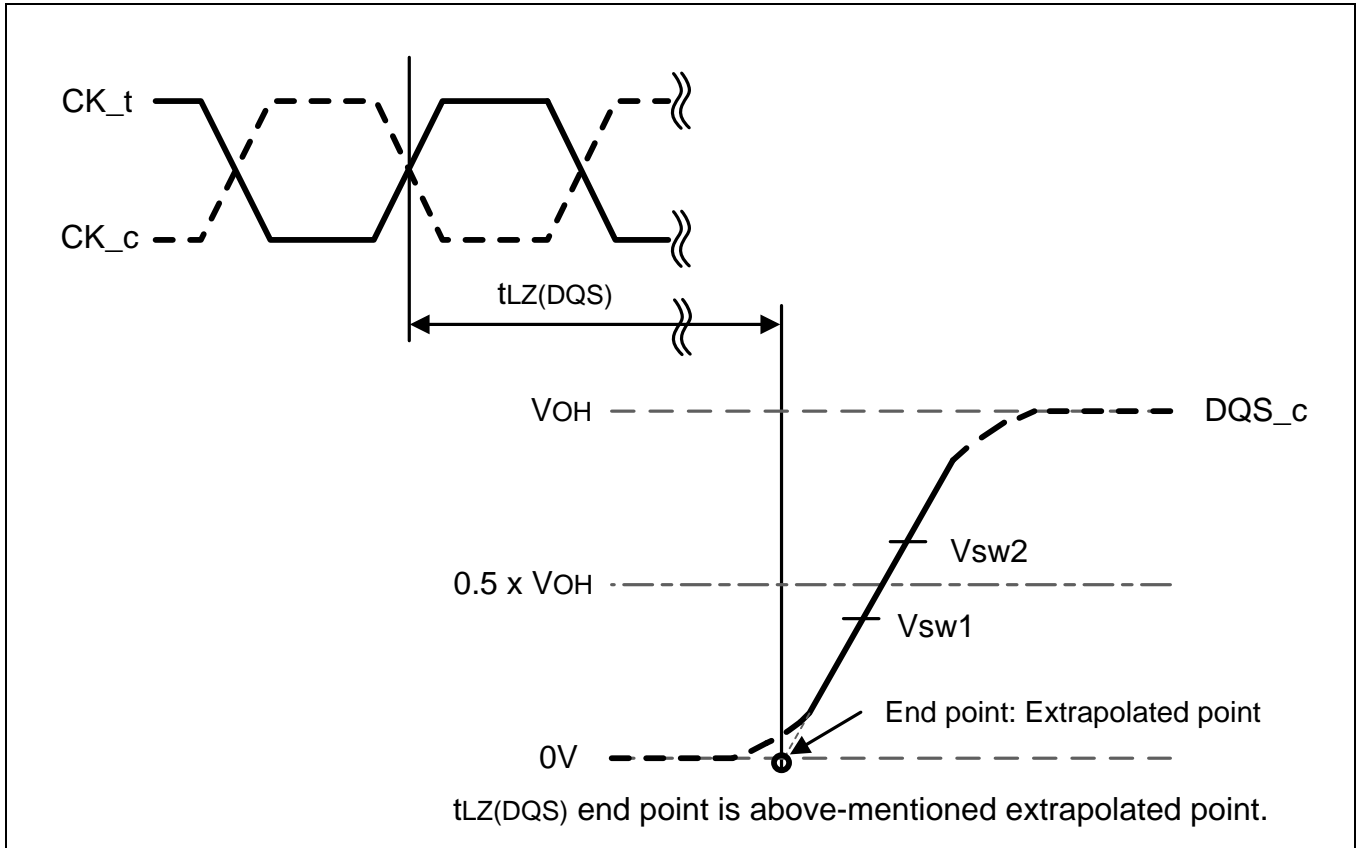

#### Notes:

1. Conditions for Calibration: Pull Down Driver Ron = 40ohm, VOH = VDDQ\*0.5.
2. Termination condition for DQS\_t and DQS\_C = 50ohm to VSSQ.
3. The VOH level depends on MR22 OP[2:0] and MR3 OP[0] settings as well as device tolerances.  
Use the actual VOH value for tHZ and tLZ measurements.

**Figure 12 - tLZ(DQS) method for calculating transitions and end point**



CK\_t - CK\_c crossing at 2nd CAS-2 of Read Command

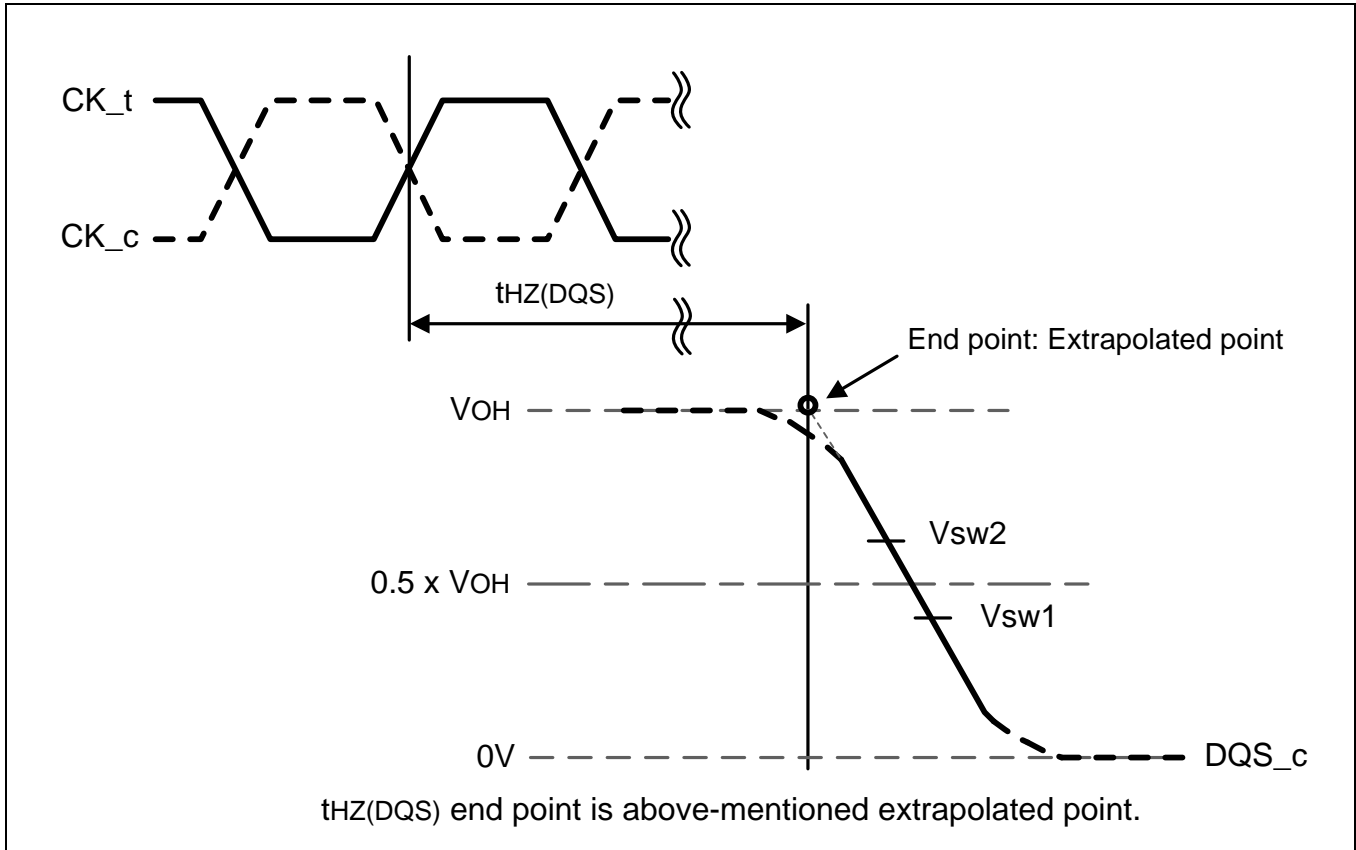

**Notes:**

1. Conditions for Calibration: Pull Down Driver Ron = 40ohm, VOH = VDDQ\*0.5.
2. Termination condition for DQS\_t and DQS\_C = 50ohm to VSSQ.
3. The VOH level depends on MR22 OP[2:0] and MR3 OP[0] settings as well as device tolerances.  
Use the actual VOH value for tHZ and tLZ measurements.

**Figure 13 - tHZ(DQS) method for calculating transitions and end point**

**Table 15 - Reference Voltage for tLZ(DQS), tHZ(DQS) Timing Measurements**

Measured Parameter	Measured Parameter Symbol	Vsw1[V]	Vsw2[V]	Note
DQS_c low-impedance time from CK_t, CK_c	tLZ(DQS)	0.4 x VOH	0.6 x VOH	
DQS_c high impedance time from CK_t, CK_c	tHZ(DQS)	0.4 x VOH	0.6 x VOH	



### 7.4.7.2 tLZ(DQ) and tHZ(DQ) Calculation for ATE (Automatic Test Equipment)

CK\_t - CK\_c crossing at 2nd CAS-2 of Read Command

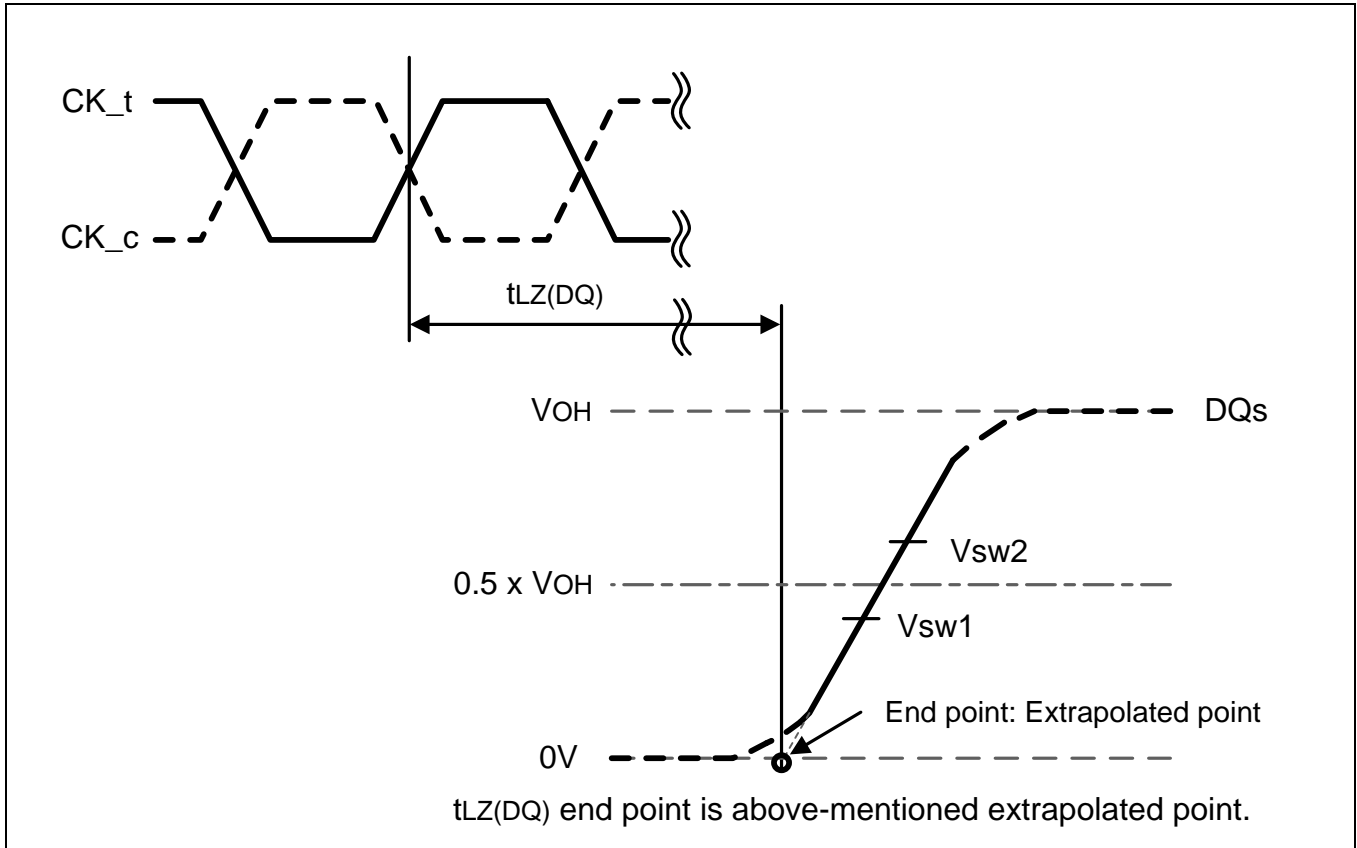

#### Notes:

1. Conditions for Calibration: Pull Down Driver Ron = 40ohm, VOH = VDDQ\*0.5.
2. Termination condition for DQ and DMI = 50ohm to VSSQ.
3. The VOH level depends on MR22 OP[2:0] and MR3 OP[0] settings as well as device tolerances.  
Use the actual VOH value for tHZ and tLZ measurements.

Figure 14 - tLZ(DQ) method for calculating transitions and end point



CK\_t - CK\_c crossing at 2nd CAS-2 of Read Command

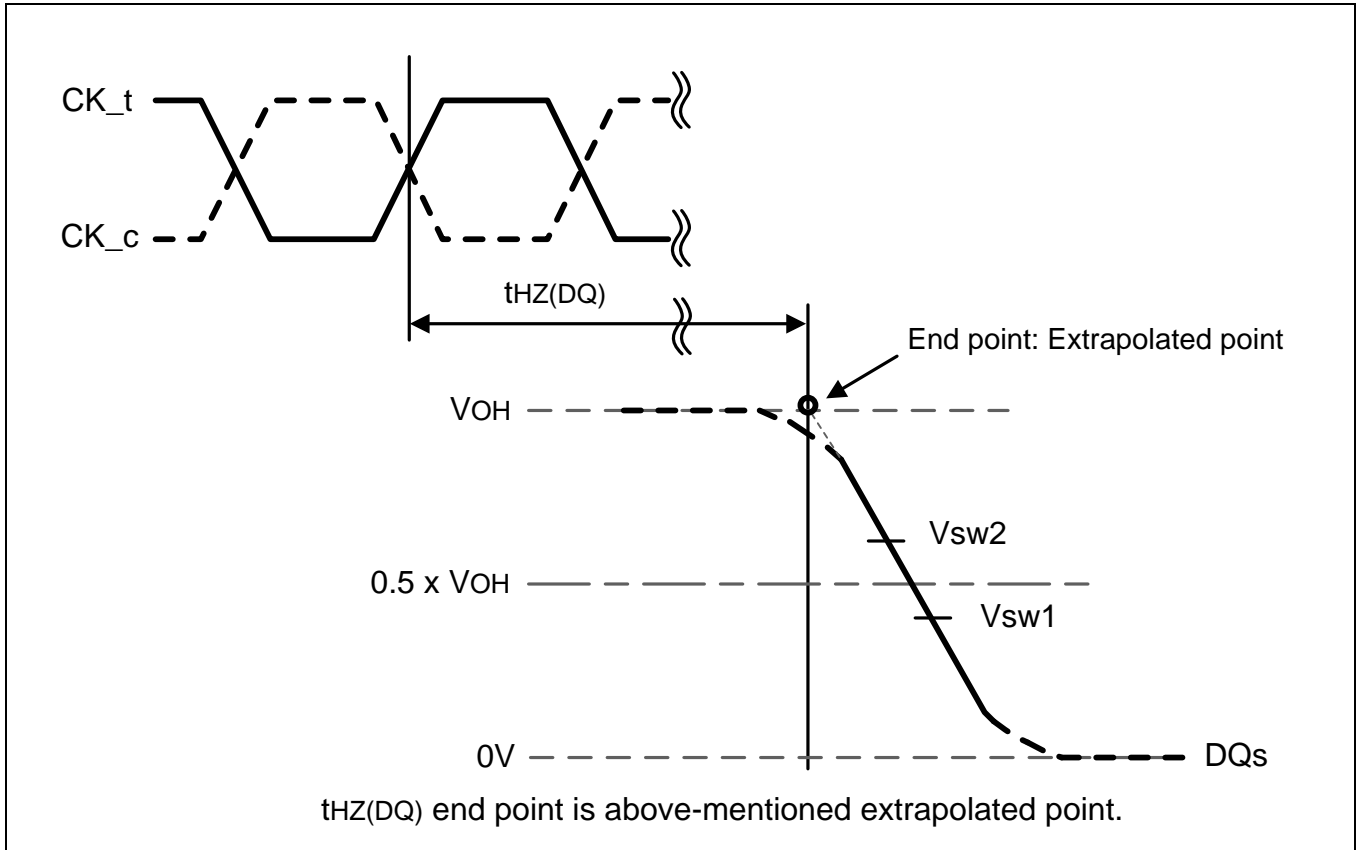

**Notes:**

1. Conditions for Calibration: Pull Down Driver Ron = 40ohm, VOH = VDDQ\*0.5.
2. Termination condition for DQ and DMI = 50ohm to VSSQ.
3. The VOH level depends on MR22 OP[2:0] and MR3 OP[0] settings as well as device tolerances.  
Use the actual VOH value for tHZ and tLZ measurements.

**Figure 15 - tHZ(DQ) method for calculating transitions and end point**

**Table 16 - Reference Voltage for tLZ(DQ), tHZ(DQ) Timing Measurements**

Measured Parameter	Measured Parameter Symbol	Vsw1[V]	Vsw2[V]	Note
DQ low-impedance time from CK_t, CK_c	tLZ(DQ)	0.4 x VOH	0.6 x VOH	
DQ high impedance time from CK_t, CK_c	tHZ(DQ)	0.4 x VOH	0.6 x VOH	



7.4.7.3 tRPRE Calculation for ATE (Automatic Test Equipment)

The method for calculating differential pulse widths for tRPRE is shown in Figure 16 and Figure 17.

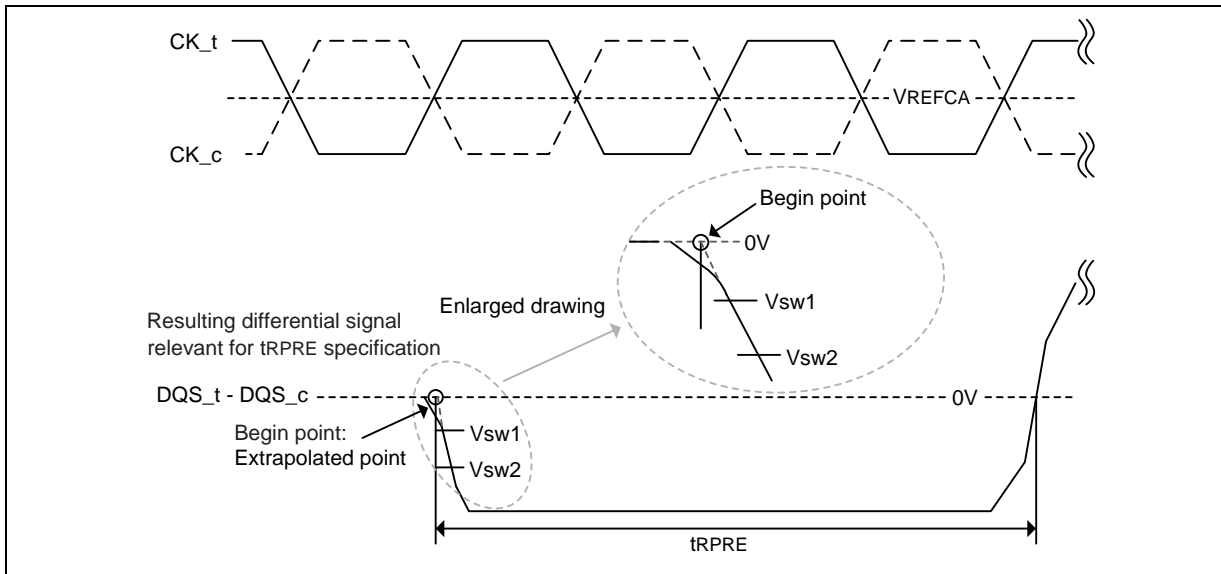

Notes:

1. Conditions for Calibration: Pull Down Driver Ron = 40ohm, VOH = VDDQ\*0.5.
2. Termination condition for DQS\_t, DQS\_c, DQ and DMI = 50ohm to VSSQ.
3. Preamble = Static.

Figure 16 - Method for calculating tRPRE transitions and endpoints

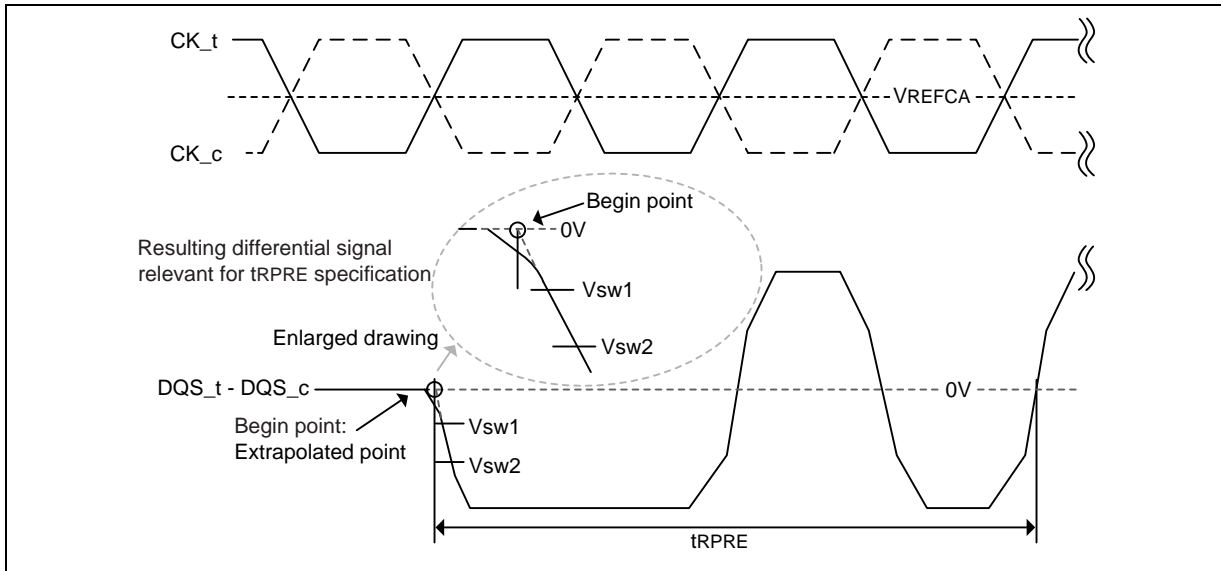

Notes:

1. Conditions for Calibration: Pull Down Driver Ron = 40ohm, VOH = VDDQ\*0.5.
2. Termination condition for DQS\_t, DQS\_c, DQ and DMI = 50ohm to VSSQ.
3. Preamble = Toggle.

Figure 17 - Method for calculating tRPRE transitions and endpoints

Table 17 - Reference Voltage for tRPRE Timing Measurements

Measured Parameter	Measured Parameter Symbol	Vsw1[V]	Vsw2[V]	Note
DQS_t, DQS_c differential Read Preamble	tRPRE	-(0.3 x VOH)	-(0.7 x VOH)	



7.4.7.4 tRPST Calculation for ATE (Automatic Test Equipment)

The method for calculating differential pulse widths for tRPST is shown in Figure 18.

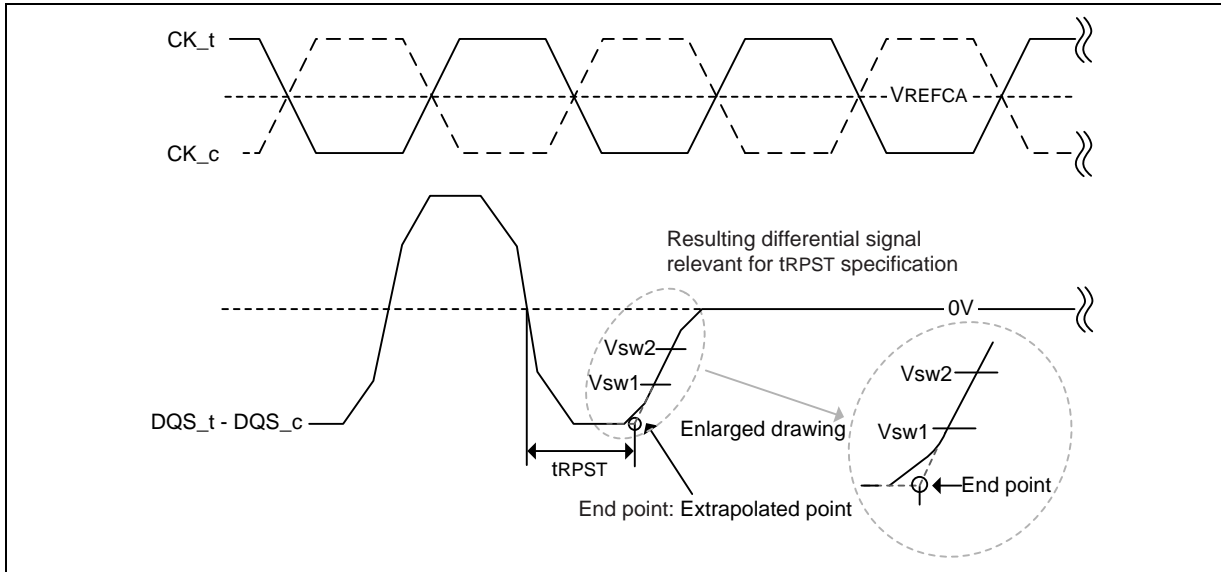

Notes:

1. Conditions for Calibration: Pull Down Driver Ron = 40ohm, VOH = VDDQ\*0.5.
2. Termination condition for DQS\_t, DQS\_c, DQ and DMI = 50ohm to VSSQ.
3. Read Postamble: 0.5tCK.
4. The method for calculating differential pulse widths for 1.5 tCK Postamble is same as 0.5 tCK Postamble.

Figure 18 - Method for calculating tRPST transitions and endpoints

Table 18 - Reference Voltage for tRPST Timing Measurements

Measured Parameter	Measured Parameter Symbol	Vsw1[V]	Vsw2[V]	Note
DQS_t, DQS_c differential Read Postamble	tRPST	-(0.7 x VOH)	-(0.3 x VOH)	

Table 19 - Read AC Timing

Parameter	Symbol	Min/Max	Data Rate							Unit	
			533	1066	1600	2133	2667	3200	3733		4267
Read Timing			533	1066	1600	2133	2667	3200	3733	4267	
READ preamble	tRPRE	Min	1.8							tCK(avg)	
0.5 tCK READ postamble	tRPST	Min	0.4							tCK(avg)	
1.5 tCK READ postamble	tRPST	Min	1.4							tCK(avg)	
DQ low-impedance time from CK_t, CK_c	tLZ(DQ)	Min	(RL x tCK) + tDQSCK(Min) - 200pS							pS	
DQ high impedance time from CK_t, CK_c	tHZ(DQ)	Max	(RL x tCK) + tDQSCK(Max) + tDQSQ(Max) + (BL/2 x tCK) - 100pS							pS	
DQS_c low-impedance time from CK_t, CK_c	tLZ(DQS)	Min	(RL x tCK) + tDQSCK(Min) - (tRPRE(Max) x tCK) - 200pS							pS	
DQS_c high impedance time from CK_t, CK_c	tHZ(DQS)	Max	(RL x tCK) + tDQSCK(Max) + (BL/2 x tCK) + (tRPST(Max) x tCK) - 100pS							pS	
DQS-DQ skew	tDQSQ	Max	0.18							UI	



## 7.4.8 tDQSCK Timing Table

Table 20 - tDQSCK Timing Table

Parameter	Symbol	Min	Max	Unit	Notes
DQS Output Access Time from CK_t/CK_c	tDQSCK	1.5	3.5	nS	1
DQS Output Access Time from CK_t/CK_c - Temperature Variation	tDQSCK_temp	-	4	pS/°C	2
DQS Output Access Time from CK_t/CK_c - Voltage Variation	tDQSCK_volt	-	7	pS/mV	3

**Notes:**

1. Includes DRAM process, voltage and temperature variation. It includes the AC noise impact for frequencies > 20 MHz and max voltage of 45 mV pk-pk from DC-20 MHz at a fixed temperature on the package. The voltage supply noise must comply with the component Min-Max DC Operating conditions.
2. tDQSCK\_temp max delay variation as a function of Temperature.
3. tDQSCK\_volt max delay variation as a function of DC voltage variation for VDDQ and VDD2. tDQSCK\_volt should be used to calculate timing variation due to VDDQ and VDD2 noise < 20 MHz. Host controller do not need to account for any variation due to VDDQ and VDD2 noise > 20 MHz. The voltage supply noise must comply with the component Min-Max DC Operating conditions.

The voltage variation is defined as the

$$\text{Max}[\text{abs}\{\text{tDQSCKmin@V1} - \text{tDQSCKmax@V2}\}, \text{abs}\{\text{tDQSCKmax@V1} - \text{tDQSCKmin@V2}\}] / \text{abs}\{V1 - V2\}.$$

For tester measurement VDDQ = VDD2 is assumed.

## 7.4.8.1 CK to DQS Rank to Rank variation

Table 21 - tDQSCK\_rank2rank Timing Table

Parameter	Symbol	Min/Max	Data Rate						Unit	Notes
			1600	1866	2133	2400	3200	3733		
Read Timing										
CK to DQS Rank to Rank variation	tDQSCK_rank2rank	Max	1.0						nS	1, 2

**Notes:**

1. The same voltage and temperature are applied to tDQS2CK\_rank2rank.
2. tDQSCK\_rank2rank parameter is applied to multi-ranks per byte lane within a package consisting of the same design dies.





**7.4.9 Write Preamble and Postamble**

The DQS strobe for the LPDDR4X-SDRAM requires a pre-amble prior to the first latching edge (the rising edge of DQS<sub>t</sub> with DATA “valid”), and it requires a post-amble after the last latching edge. The preamble and postamble lengths are set via mode register writes (MRW).

For WRITE operations, a 2\*tCK preamble is required at all operating frequencies.

LPDDR4X will have a DQS Write post-amble of 0.5\*tCK or extended to 1.5\*tCK. Standard DQS postamble will be 0.5\*tCK driven by the memory controller for Writes. A mode register setting instructs the DRAM to drive an additional (extended) one cycle DQS Write postamble. The drawings below show examples of DQS Write postamble for both standard (tWPST) and extended (tWPSTE) postamble operation.

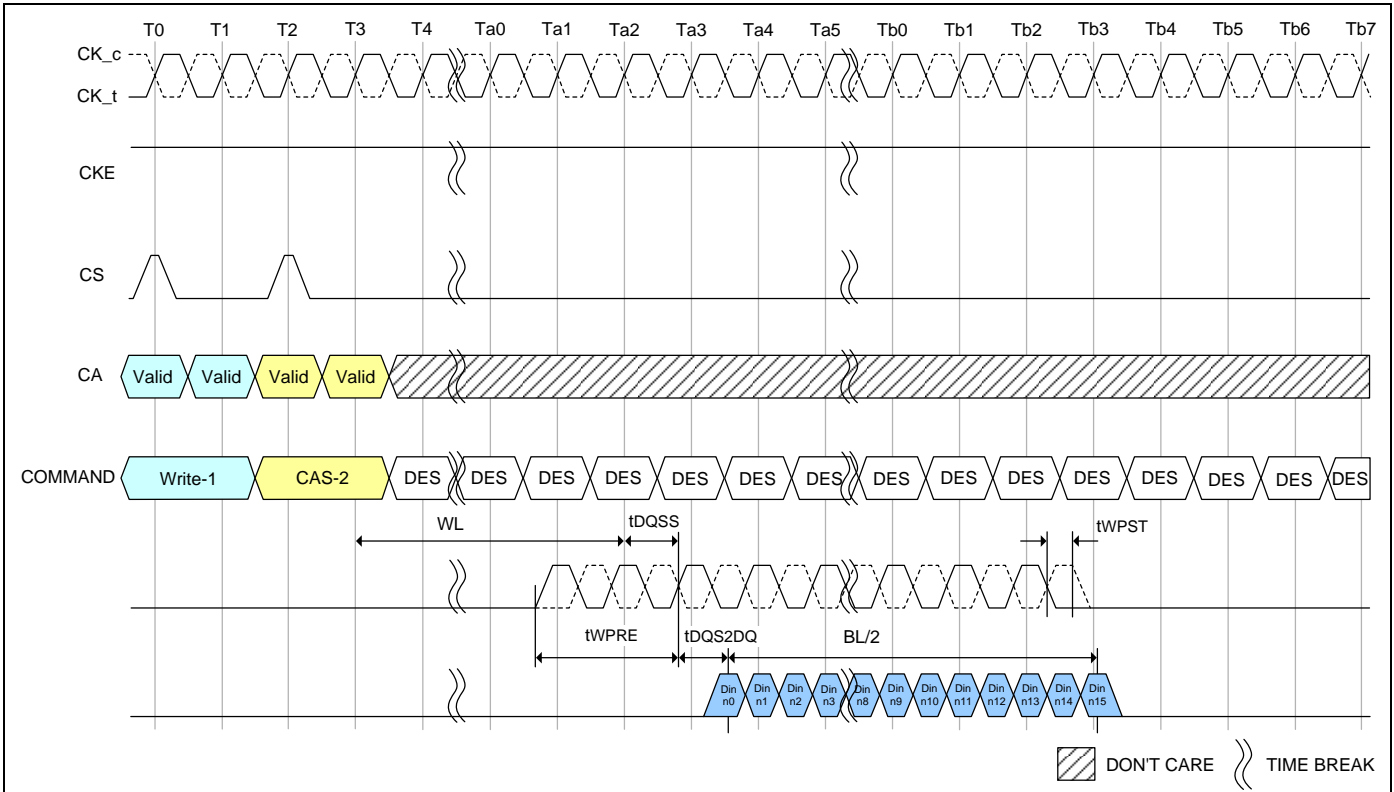

**Notes:**

1. BL = 16, Postamble = 0.5nCK.
2. DQS and DQ terminated VSSQ.
3. DQS<sub>t</sub>/DQS<sub>c</sub> is “don’t care” prior to the start of tWPRE.  
No transition of DQS is implied, as DQS<sub>t</sub>/DQS<sub>c</sub> can be HIGH, LOW, or HI-Z prior to tWPRE.

**Figure 19 - DQS Write Preamble and Postamble: 0.5nCK Postamble**

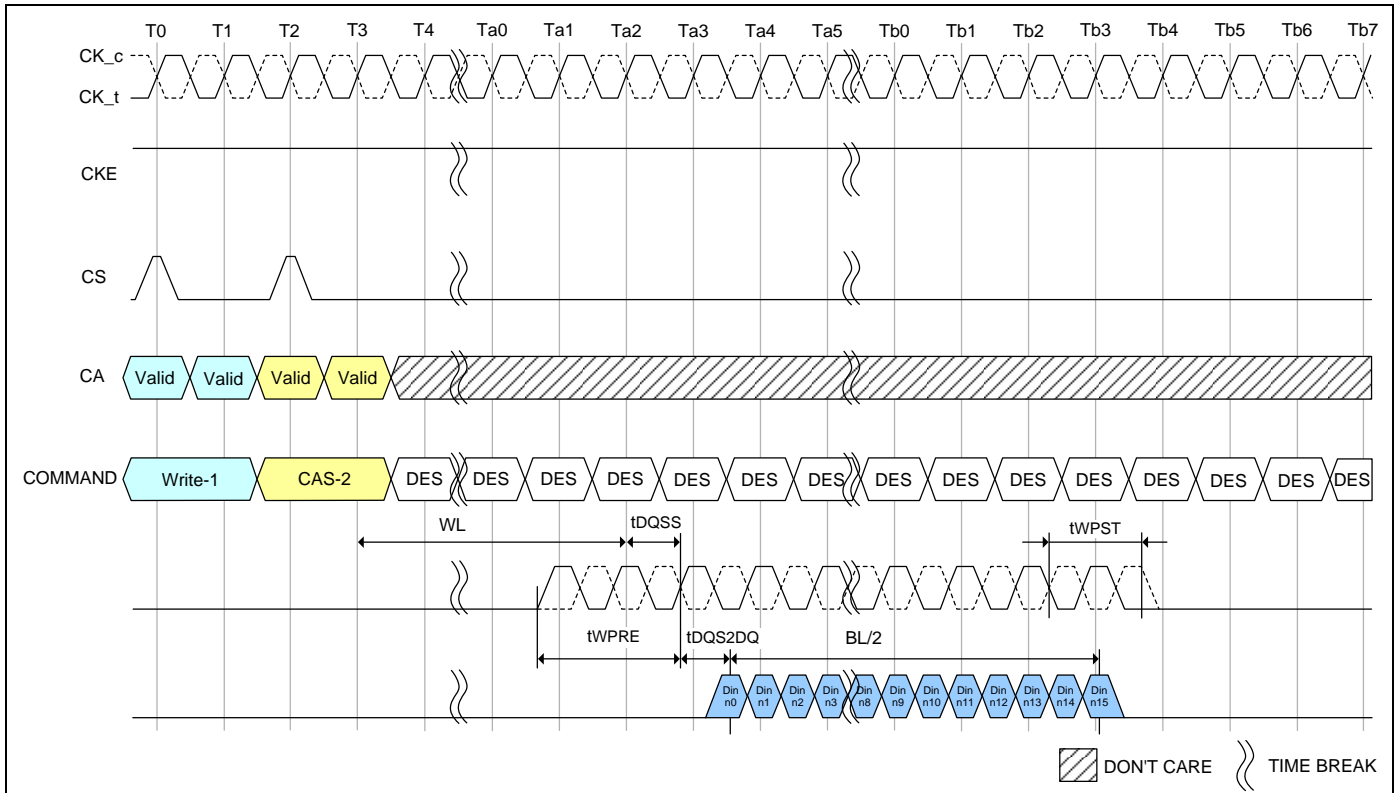

**Notes:**

1. BL = 16, Postamble = 1.5nCK.
2. DQS and DQ terminated VSSQ.
3. DQS<sub>t</sub>/DQS<sub>c</sub> is "don't care" prior to the start of tWPST.  
No transition of DQS is implied, as DQS<sub>t</sub>/DQS<sub>c</sub> can be HIGH, LOW, or HI-Z prior to tWPST.

**Figure 20 - DQS Write Preamble and Postamble: 1.5nCK Postamble**

**7.4.10 Burst Write Operation**

A burst WRITE command is initiated with CS, and CA[5:0] asserted to the proper state at the rising edge of CK, as defined by the Command Truth Table. Column addresses C[3:2] should be driven LOW for Burst WRITE commands, and column addresses C[1:0] are not transmitted on the CA bus (and are assumed to be zero), so that the starting column burst address is always aligned with a 32B boundary. The write latency (WL) is defined from the last rising edge of the clock that completes a write command (Ex: the second rising edge of the CAS-2 command) to the rising edge of the clock from which tDQSS is measured. The first valid "latching" edge of DQS must be driven WL \* tCK + tDQSS after the rising edge of Clock that completes a write command.

The LPDDR4X-SDRAM uses an un-matched DQS-DQ path for lower power, so the DQS-strobe must arrive at the SDRAM ball prior to the DQ signal by the amount of tDQS2DQ. The DQS-strobe output is driven tWPST before the first valid rising strobe edge. The tWPST pre-amble is required to be 2 x tCK. The DQS strobe must be trained to arrive at the DQ pad center-aligned with the DQ-data. The DQ-data must be held for tDIVW (data input valid window) and the DQS must be periodically trained to stay centered in the tDIVW window to compensate for timing changes due to temperature and voltage variation. Burst data is captured by the SDRAM on successive edges of DQS until the 16 or 32 bit data burst is complete. The DQS-strobe must remain active (toggling) for tWPST (WRITE post-amble) after the completion of the burst WRITE. After a burst WRITE operation, tWR must be satisfied before a PRECHARGE command to the same bank can be issued. Pin input timings are measured relative to the cross point of DQS<sub>t</sub> and DQS<sub>c</sub>.

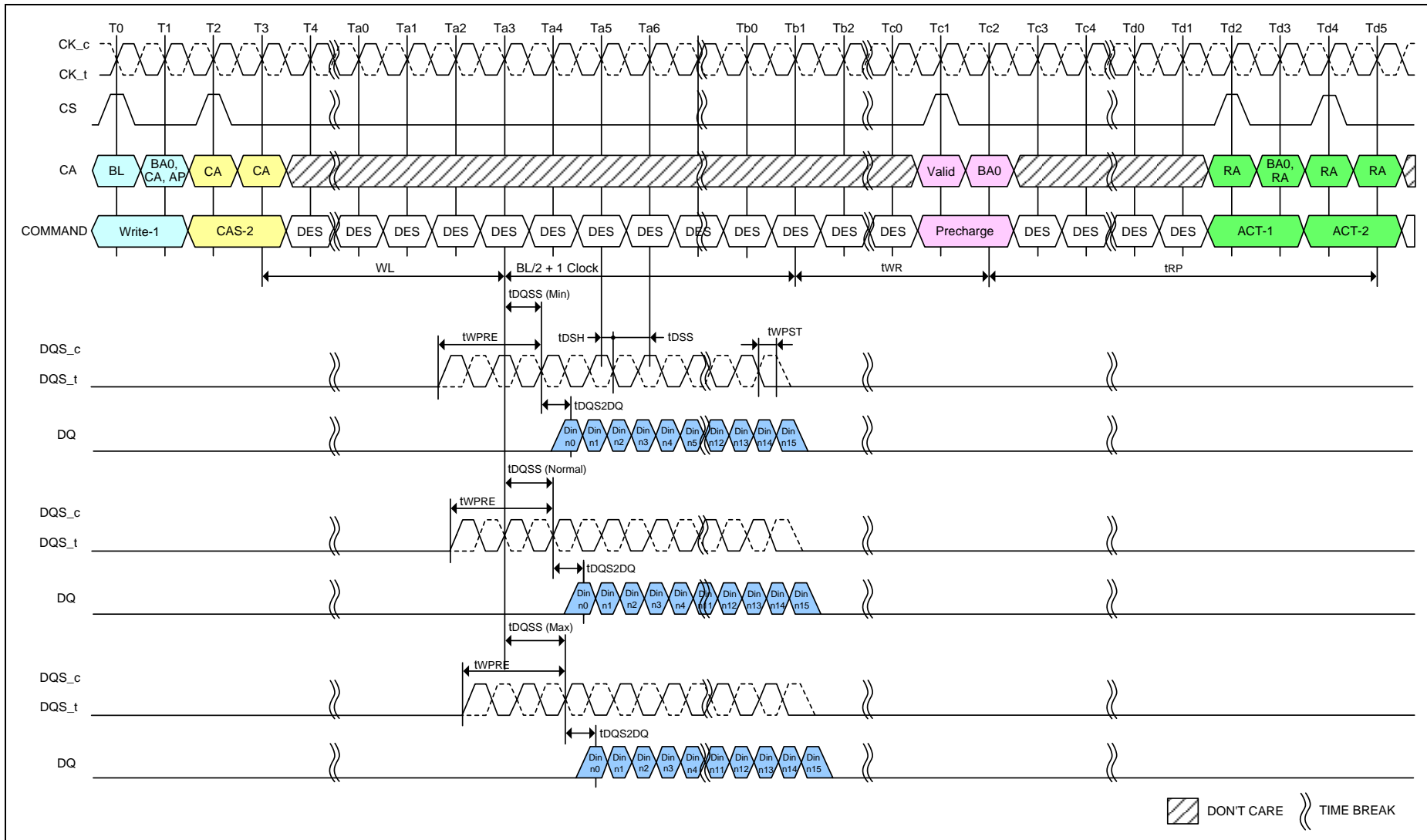

**Notes:**

1. BL=16, Write Postamble = 0.5nCK, DQ/DQS: VSSQ termination.
2. Din n = data-in to column n.
3. The minimum number of clock cycles from the burst write command to the precharge command for same bank is  $[WL + 1 + BL/2 + RU(tWR/tCK)]$ .
4. tWR starts at the rising edge of CK after the last latching edge of DQS.
5. DES commands are shown for ease of illustration; other commands may be valid at these times.

**Figure 21 - Burst Write Operation**

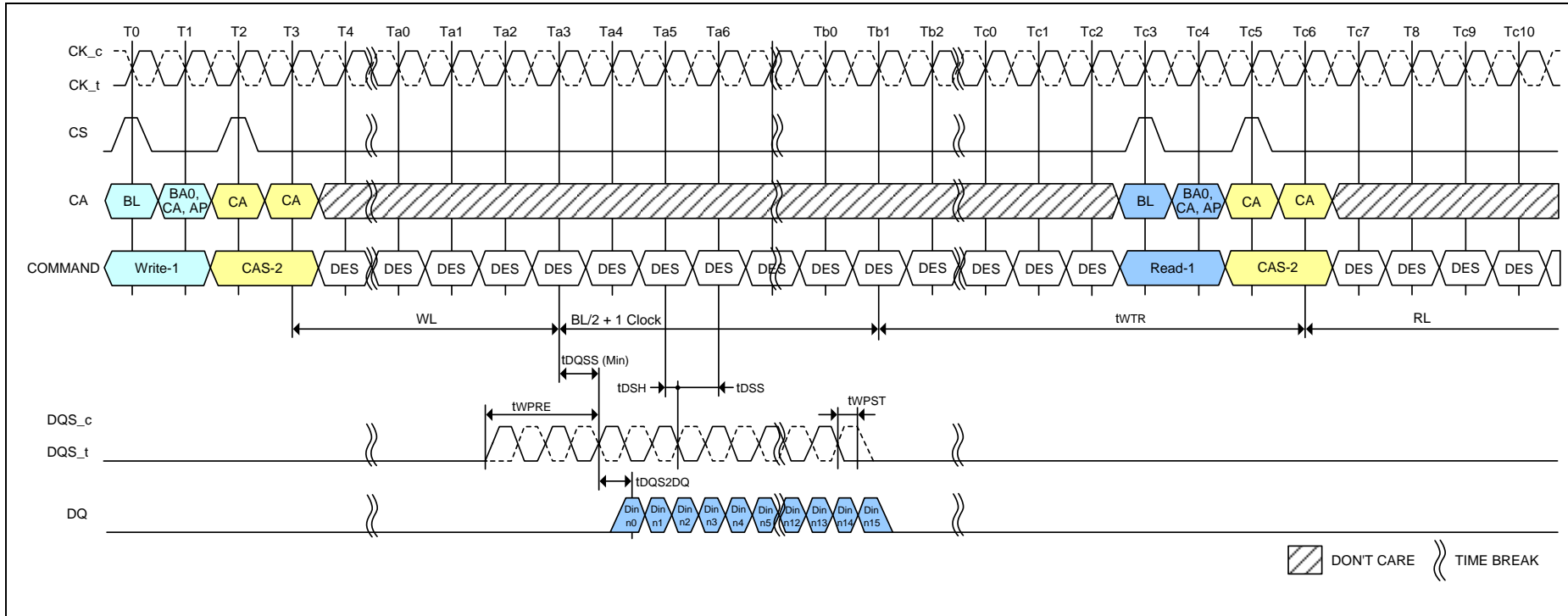

**Notes:**

1. BL=16, Write Postamble = 0.5nCK, DQ/DQS: VSSQ termination.
2. Din n = data-in to column n.
3. The minimum number of clock cycles from the burst write command to the burst read command for any bank is  $\lceil WL + 1 + BL/2 + RU(twTR/tCK) \rceil$ .
4. twTR starts at the rising edge of CK after the last latching edge of DQS.
5. DES commands are shown for ease of illustration; other commands may be valid at these times.

**Figure 22 - Burst Write Followed by Burst Read**



7.4.11 Write Timing

The write timing is shown in Figure 23.

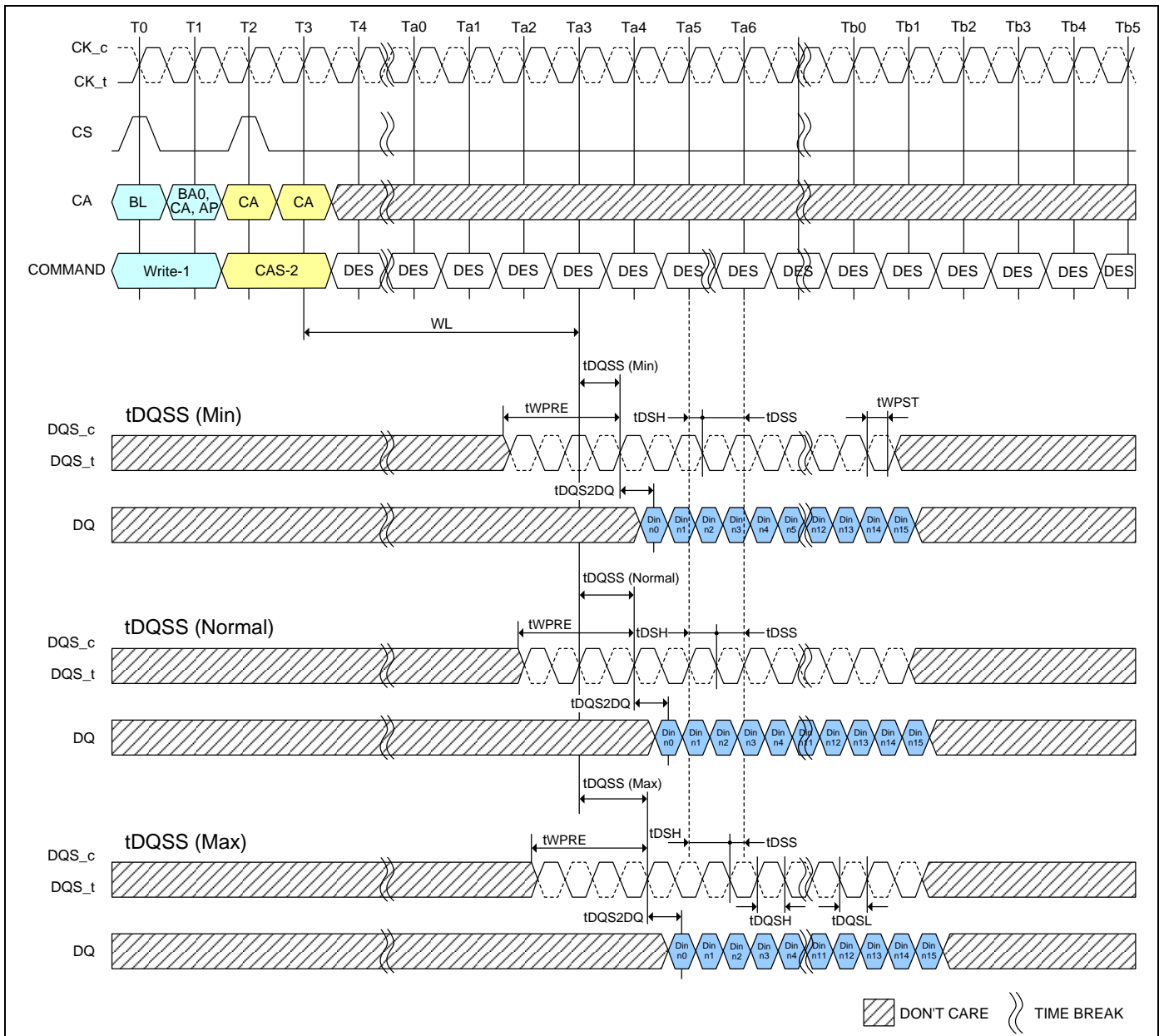

Notes:

1. BL=16, Write Postamble = 0.5nCK.
2. Din n = data-in to column n.
3. DES commands are shown for ease of illustration; other commands may be valid at these times.

Figure 23 - Write Timing



7.4.11.1 tWPRE Calculation for ATE (Automatic Test Equipment)

The method for calculating differential pulse widths for tWPRE is shown in Figure 24.

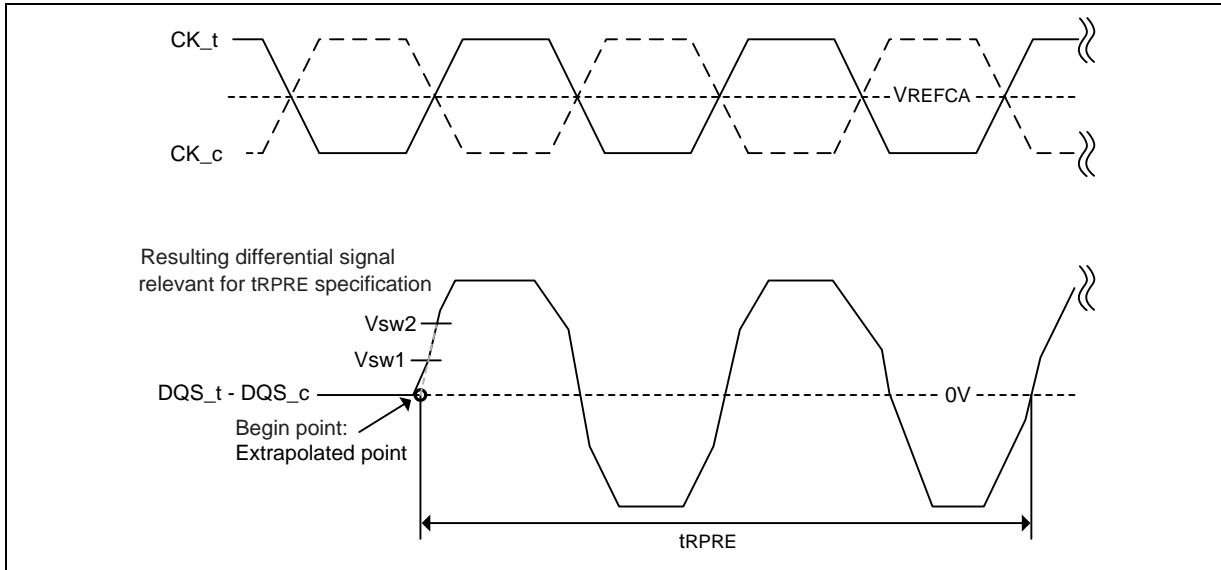

**Note:**

1. Termination condition for DQS\_t, DQS\_c, DQ and DMI = 50ohm to VSSQ.

**Figure 24 - Method for calculating tWPRE transitions and endpoints**

**Table 22 - Reference Voltage for tWPRE Timing Measurements**

Measured Parameter	Measured Parameter Symbol	Vsw1[V]	Vsw2[V]	Note
DQS_t, DQS_c differential WRITE Preamble	tWPRE	VIHL_AC x 0.3	VIHL_AC x 0.7	



7.4.11.2 tWPST Calculation for ATE (Automatic Test Equipment)

The method for calculating differential pulse widths for tWPST is shown in Figure 25.

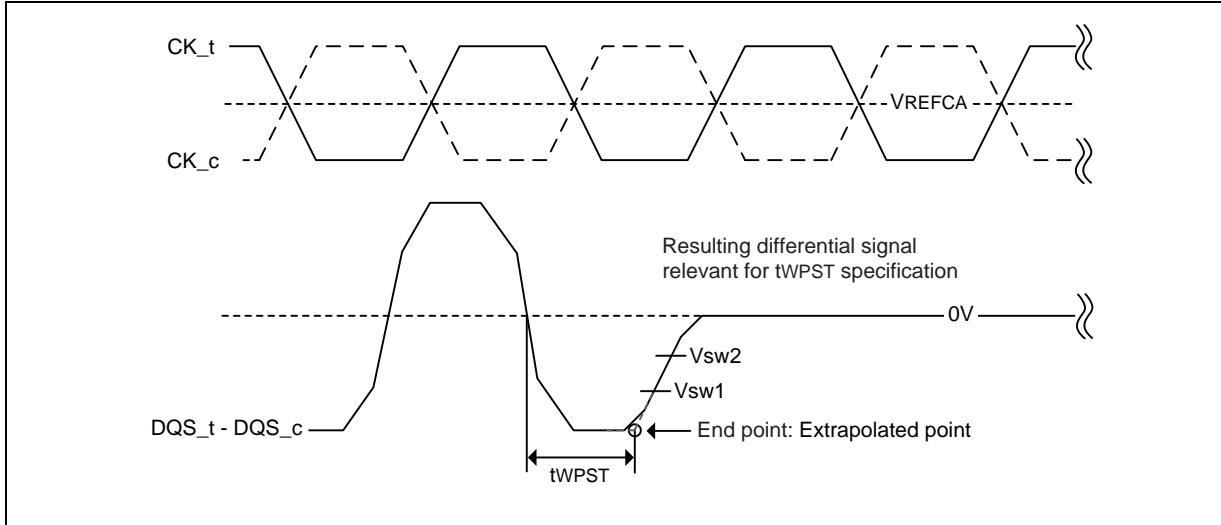

**Note:**

1. Termination condition for DQS\_t, DQS\_c, DQ and DMI = 50ohm to VSSQ.
2. Write Postamble: 0.5tCK.
3. The method for calculating differential pulse widths for 1.5 tCK Postamble is same as 0.5 tCK Postamble.

**Figure 25 - Method for calculating tWPST transitions and endpoints**

**Table 23 - Reference Voltage for tWPST Timing Measurements**

Measured Parameter	Measured Parameter Symbol	Vsw1[V]	Vsw2[V]	Note
DQS_t, DQS_c differential WRITE Postamble	tWPST	- (VIHL_AC x 0.7)	- (VIHL_AC x 0.3)	

**Table 24 - Write AC Timing**

Parameter	Symbol	Min/Max	Data Rate							Unit	Note
			533	1066	1600	2133	2667	3200	3733		
<b>Write Timing</b>											
Write command to 1st DQS latching	tDQSS	Min	0.75							tCK(avg)	
		Max	1.25								
DQS input high-level	tDQSH	Min	0.4							tCK(avg)	
DQS input low-level width	tDQSL	Min	0.4							tCK(avg)	
DQS falling edge to CK setup time	tDSS	Min	0.2							tCK(avg)	
DQS falling edge hold time from CK	tDSH	Min	0.2							tCK(avg)	
Write preamble	tWPRE	Min	1.8							tCK(avg)	
0.5 tCK Write postamble	tWPST	Min	0.4							tCK(avg)	1
1.5 tCK Write postamble	tWPST	Min	1.4							tCK(avg)	1

**Note:**

1. The length of Write Postamble depends on MR3 OP1 setting.





### 7.4.12 Read and Write Latencies

Table 25 - Read and Write Latencies

Read Latency		Write Latency		nWR	nRTP	Lower Clock Frequency Limit [MHz] (>)	Upper Clock Frequency Limit [MHz] (≤)	Notes
No DBI	w/ DBI	Set A	Set B					
6	6	4	4	6	8	10	266	1, 2, 3, 4, 5, 6
10	12	6	8	10	8	266	533	
14	16	8	12	16	8	533	800	
20	22	10	18	20	8	800	1066	
24	28	12	22	24	10	1066	1333	
28	32	14	26	30	12	1333	1600	
32	36	16	30	34	14	1600	1866	
36	40	18	34	40	16	1866	2133	

#### Notes:

1. The LPDDR4X SDRAM device should not be operated at a frequency above the Upper Frequency Limit, or below the Lower Frequency Limit, shown for each RL, WL, nRTP, or nWR value.
2. DBI for Read operations is enabled in MR3 OP[6]. When MR3 OP[6]=0, then the "No DBI" column should be used for Read Latency. When MR3 OP[6]=1, then the "w/DBI" column should be used for Read Latency.
3. Write Latency Set "A" and Set "B" is determined by MR2 OP[6]. When MR2 OP[6]=0, then Write Latency Set "A" should be used. When MR2 OP[6]=1, then Write Latency Set "B" should be used.
4. The programmed value of nWR is the number of clock cycles the LPDDR4X SDRAM device uses to determine the starting point of an internal Precharge operation after a Write burst with AP (Auto Precharge). It is determined by RU(tWR/tCK).
5. The programmed value of nRTP is the number of clock cycles the LPDDR4X SDRAM device uses to determine the starting point of an internal Precharge operation after a Read burst with AP (Auto Precharge). It is determined by RU(tRTP/tCK).
6. nRTP shown in this table is valid for BL16 only. For BL32, the SDRAM will add 8 clocks to the nRTP value before starting a precharge.

### 7.4.13 Write and Masked Write operation DQS controls (WDQS Control)

LPDDR4X-SDRAMs support write and masked write operations with the following DQS controls. Before and after Write and Masked Write operations are issued, DQS<sub>t</sub>/DQS<sub>c</sub> is required to have a sufficient voltage gap to make sure the write buffers operating normally without any risk of metastability.

The LPDDR4X-SDRAM is supported by either of two WDQS control modes below.

Mode 1: Read Based Control

Mode 2: WDQS<sub>on</sub> / WDQS<sub>off</sub> definition based control

Regardless of ODT enable/disable, WDQS related timing described here does not allow any change of existing command timing constraints for all read/write operation. In case of any conflict or ambiguity on the command timing constraints caused by the spec here, the spec defined in section 7.4.35, table 70 (or below) should have higher priority than WDQS control requirements.



#### 7.4.13.1 WDQS Control Mode 1 - Read Based Control

The LPDDR4X-SDRAM needs to be guaranteed the differential WDQS, but the differential WDQS can be controlled as described below. WDQS control requirements here can be ignored while differential read DQS is operated or while DQS hands over from Read to Write and vice versa.

1. At the time a write / masked write command is issued, SoC makes the transition from driving DQS\_c high to driving differential DQS\_t/DQS\_c, followed by normal differential burst on DQS pins.
2. At the end of postamble of write /masked write burst, SoC resumes driving DQS\_c high through the subsequent states except for DQS toggling and DQS turnaround time of WT-RD and RD-WT as long as CKE is high.
3. When CKE is low, the state of DQS\_t and DQS\_c is allowed to be "Don't Care".

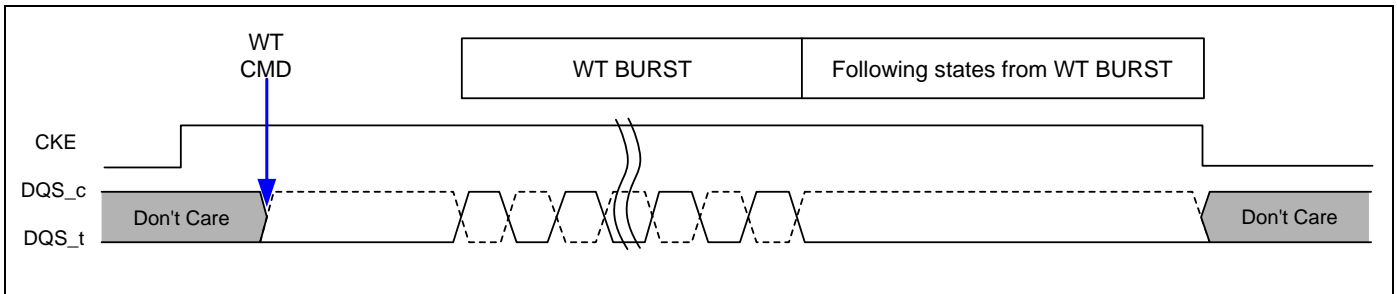

#### 7.4.13.2 WDQS Control Mode 2 - WDQS\_on/off

After write / masked write command is issued, DQS\_t and DQS\_c required to be differential from WDQS\_on, and DQS\_t and DQS\_c can be "Don't Care" status from WDQS\_off of write / masked write command. When ODT is enabled, WDQS\_on and WDQS\_off timing is located in the middle of the operations. When host disables ODT, WDQS\_on and WDQS\_off constraints conflict with tRTW. The timing does not conflict when ODT is enabled because WDQS\_on and WDQS\_off timing is covered in ODTLon and ODTLoff. However, regardless of ODT on/off, WDQS\_on/off timing below does not change any command timing constraints for all read and write operations. In order to prevent the conflict, WDQS\_on/off requirement can be ignored when WDQS\_on/off timing is overlapped with read operation period including Read burst period and tRPST or overlapped with turn-around time (RD-WT or WT-RD). In addition, the period during DQS toggling caused by Read and Write can be counted as WDQS\_on/off.

#### Parameters

- WDQS\_on: the max delay from write / masked write command to differential DQS\_t and DQS\_c.
- WDQS\_off: the min delay for DQS\_t and DQS\_c differential input after the last write / masked write command.
- WDQS\_Exception: the period where WDQS\_on and WDQS\_off timing is overlapped with read operation or with DQS turn around (RD-WT, WT-RD).
  - WDQS\_Exception @ ODT disable =  $\max(WL - WDQS\_on + tDQSTA - tWPRE - n \cdot tCK, 0 \cdot tCK)$   
where RD to WT command gap =  $tRTW(\min)@ODT \text{ disable} + n \cdot tCK$
  - WDQS\_Exception @ ODT enable = tDQSTA



Table 26 - WDQS\_on / WDQS\_off Definition

WL		nWR	nRTP	WDQS_on (max)		WDQS_off (min)		Lower Clock Frequency Limit (>)	Upper Clock Frequency Limit (≤)
Set A	Set B			Set A	Set B	Set A	Set B		
4	4	6	8	0	0	15	15	10	266
6	8	10	8	0	0	18	20	266	533
8	12	16	8	0	6	21	25	533	800
10	18	20	8	4	12	24	32	800	1066
12	22	24	10	4	14	27	37	1066	1333
14	26	30	12	6	18	30	42	1333	1600
16	30	34	14	6	20	33	47	1600	1866
18	34	40	16	8	24	36	52	1866	2133
nCK	nCK	nCK	nCK	nCK	nCK	nCK	nCK	MHz	MHz

**Notes:**

1. WDQS\_on/off requirement can be ignored when WDQS\_on/off timing is overlapped with read operation period including Read burst period and tRPST or overlapped with turn-around time (RD-WT or WT-RD).
2. The period during which DQS is toggling because of a Read or Write can be counted as part of the WDQS\_on/off requirement.

Table 27 - WDQS\_on / WDQS\_off Allowable Variation Range

	Min	Max	Unit
WDQS_On	-0.25	0.25	tCK(avg)
WDQS_Off	-0.25	0.25	tCK(avg)

Table 28 - DQS turn around parameter

Parameter	Description	Value	Unit	Note
tDQSTA	Turn-around time RDQS to WDQS for WDQS control case	TBD	-	1

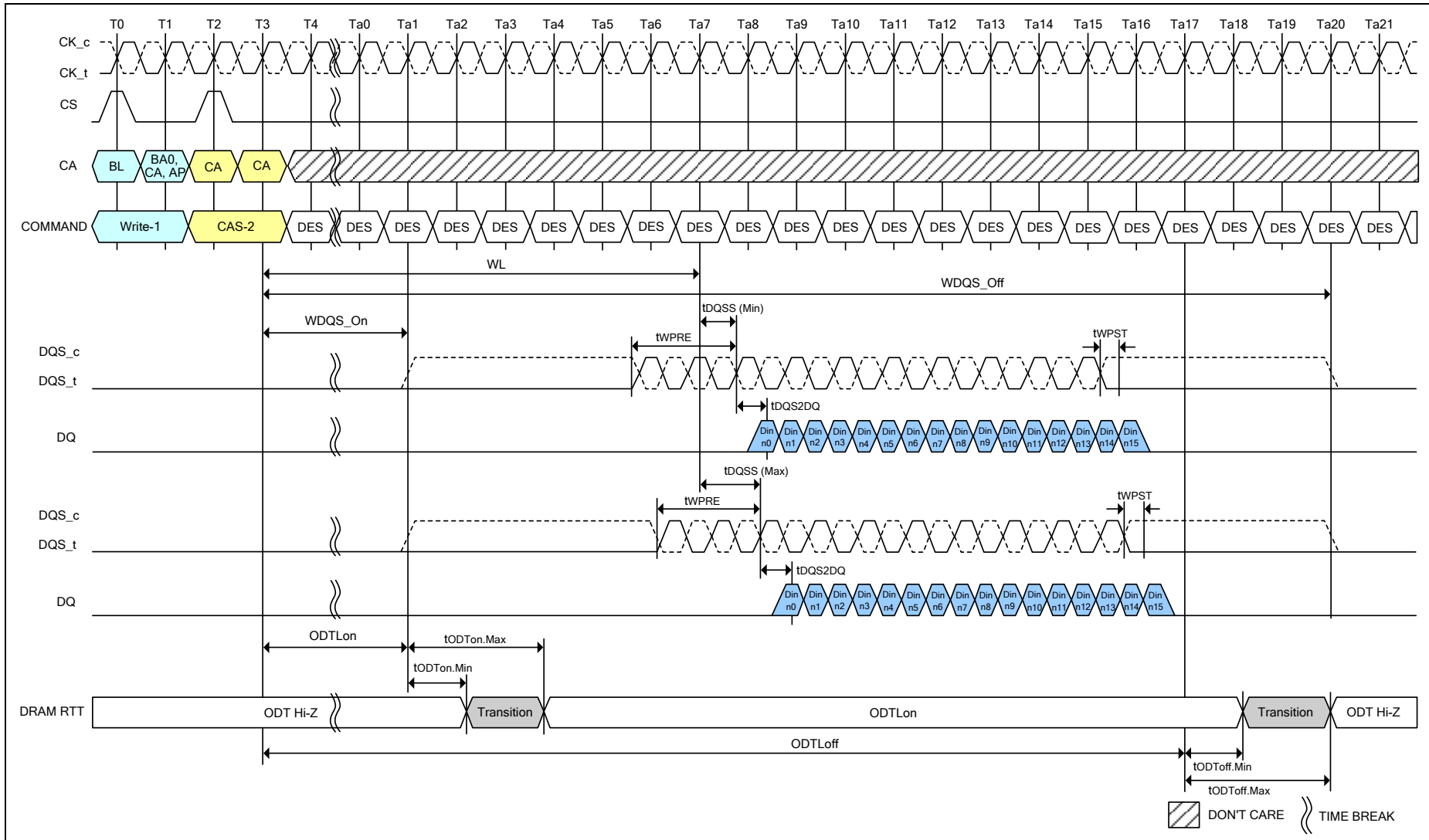

**Notes:**

1. BL=16, Write Postamble = 0.5nCK, DQ/DQS: VSSQ termination.
2. Din n = data-in to column n.
3. DES commands are shown for ease of illustration; other commands may be valid at these times.
4. DRAM RTT is only applied when ODT is enabled (MR11 OP[2:0] is not 000<sub>b</sub>).

**Figure 26 - Burst Write Operation**

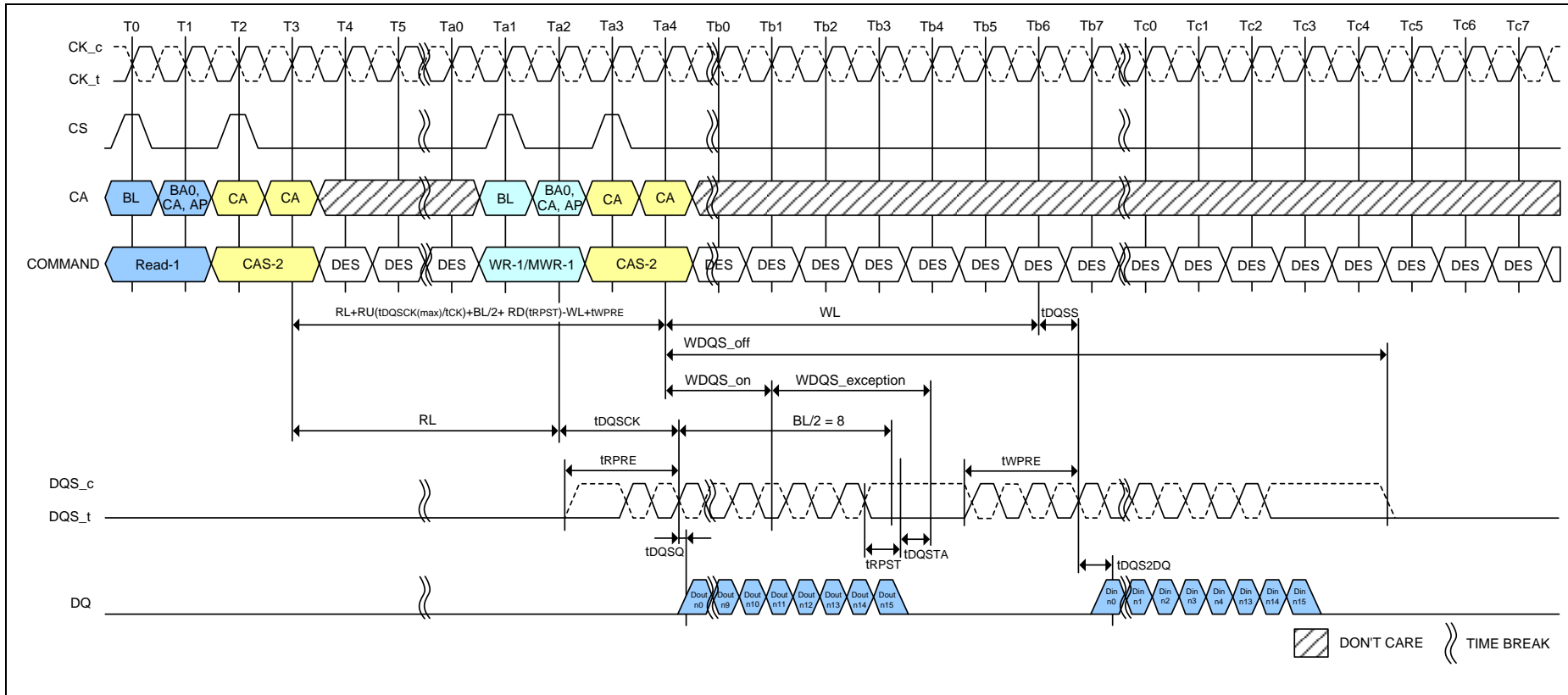

**Notes:**

1. BL=16, Read Preamble = Toggle, Read Postamble = 0.5nCK, Write Preamble = 2nCK, Write Postamble = 0.5nCK.
2. Dout n = data-out from column n and Din n = data-in to column n.
3. DES commands are shown for ease of illustration; other commands may be valid at these times.
4. WDQS\_on and WDQS\_off requirement can be ignored where WDQS\_on/off timing is overlapped with read operation period including Read burst period and tRPST or overlapped with turn-around time (RD-WT or WT-RD).

**Figure 27 - Burst Read followed by Burst Write or Burst Mask Write (ODT Disable)**

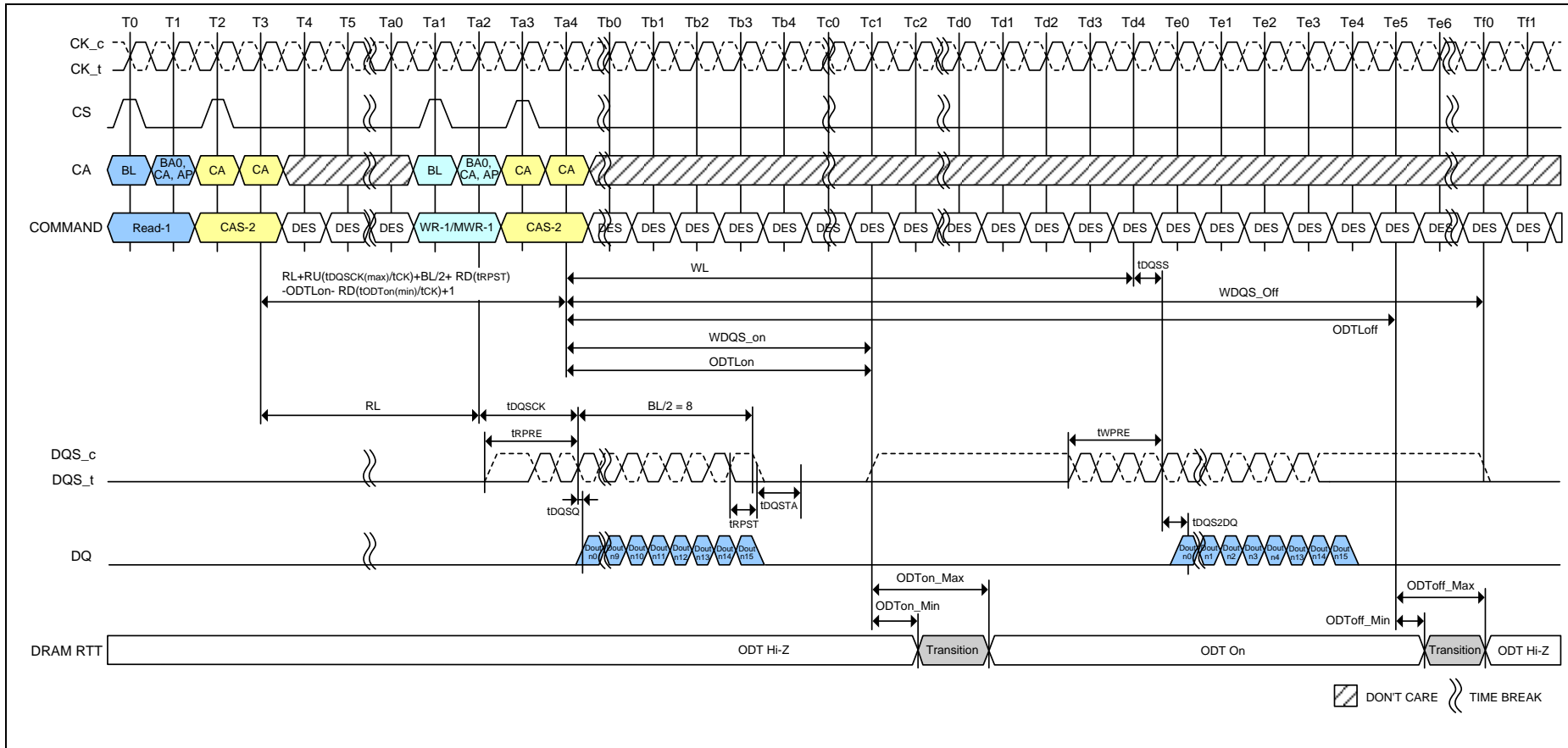

**Notes:**

1. BL=16, Read Preamble = Toggle, Read Postamble = 0.5nCK, Write Preamble = 2nCK, Write Postamble = 0.5nCK, DQ/DQS: VSSQ termination.
2. Dout n = data-out from column n and Din n = data-in to column n.
3. DES commands are shown for ease of illustration; other commands may be valid at these times.
4. WDQS\_on and WDQS\_off requirement can be ignored where WDQS\_on/off timing is overlapped with read operation period including Read burst period and tRPST or overlapped with turn-around time (RD-WT or WT-RD).

**Figure 28 - Burst Read followed by Burst Write or Burst Mask Write (ODT Enable)**



**7.4.14 Postamble and Preamble merging behavior**

The DQS strobe for the device requires a preamble prior to the first latching edge (the rising edge of DQS<sub>t</sub> with data valid), and it requires a postamble after the last latching edge. The preamble and postamble options are set via Mode Register Write commands.

In Read to Read or Write to Write operations with  $t_{CCD}=BL/2$ , postamble for 1st command and preamble for 2nd command will disappear to create consecutive DQS latching edge for seamless burst operations. But in the case of Read to Read or Write to Write operations with command interval of  $t_{CCD}+1, t_{CCD}+2$ , etc., they will not completely disappear because it's not seamless burst operations.

Timing diagrams in this material describe Postamble and Preamble merging behavior in Read to Read or Write to Write operations with  $t_{CCD}+n$ .

**7.4.14.1 Read to Read Operation**

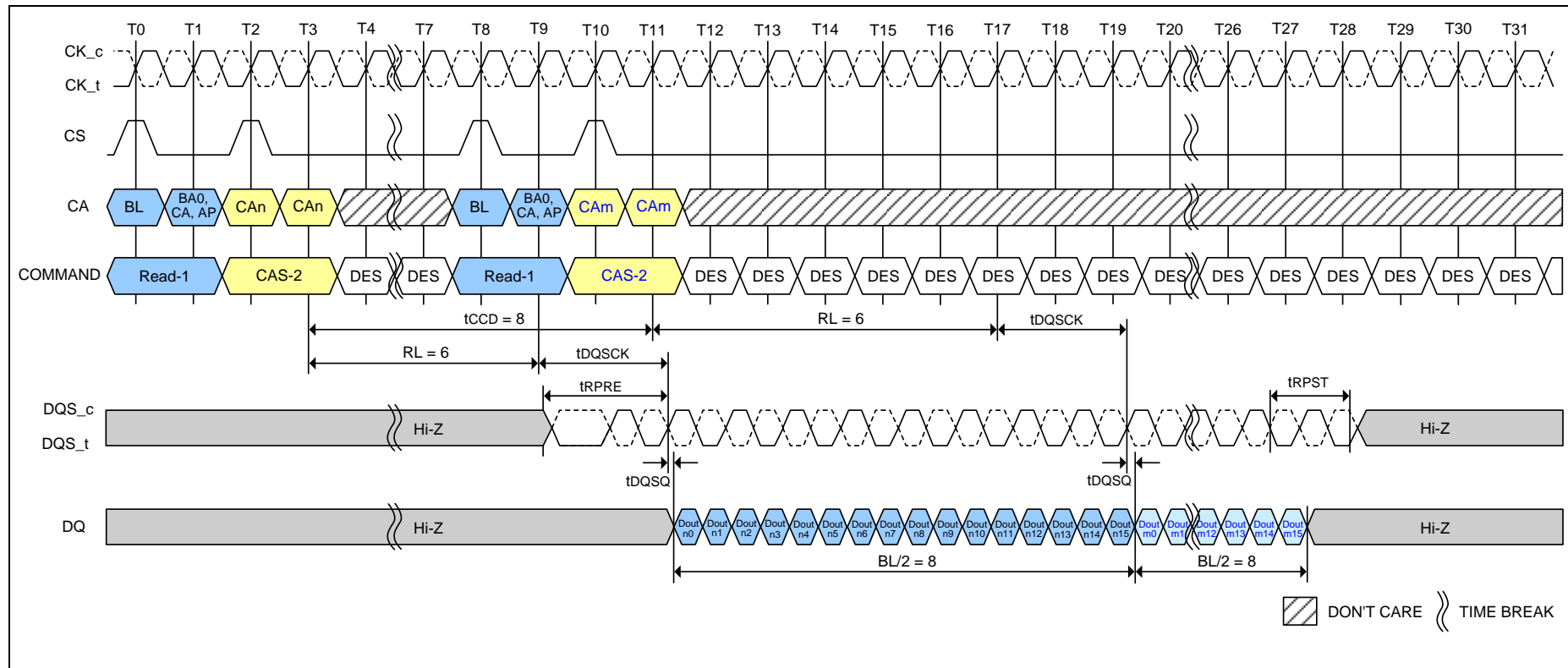

- Notes:**
1.  $BL = 16$  for column  $n$  and column  $m$ ,  $RL = 6$ , Preamble = Toggle, Postamble =  $1.5nCK$ .
  2.  $Dout\ n/m$  = data-out from column  $n$  and column  $m$ .
  3. DES commands are shown for ease of illustration; other commands may be valid at these times.

**Figure 29 - Seamless Reads Operation:  $t_{CCD} = \text{Min}$ , Preamble = Toggle,  $1.5nCK$  Postamble**

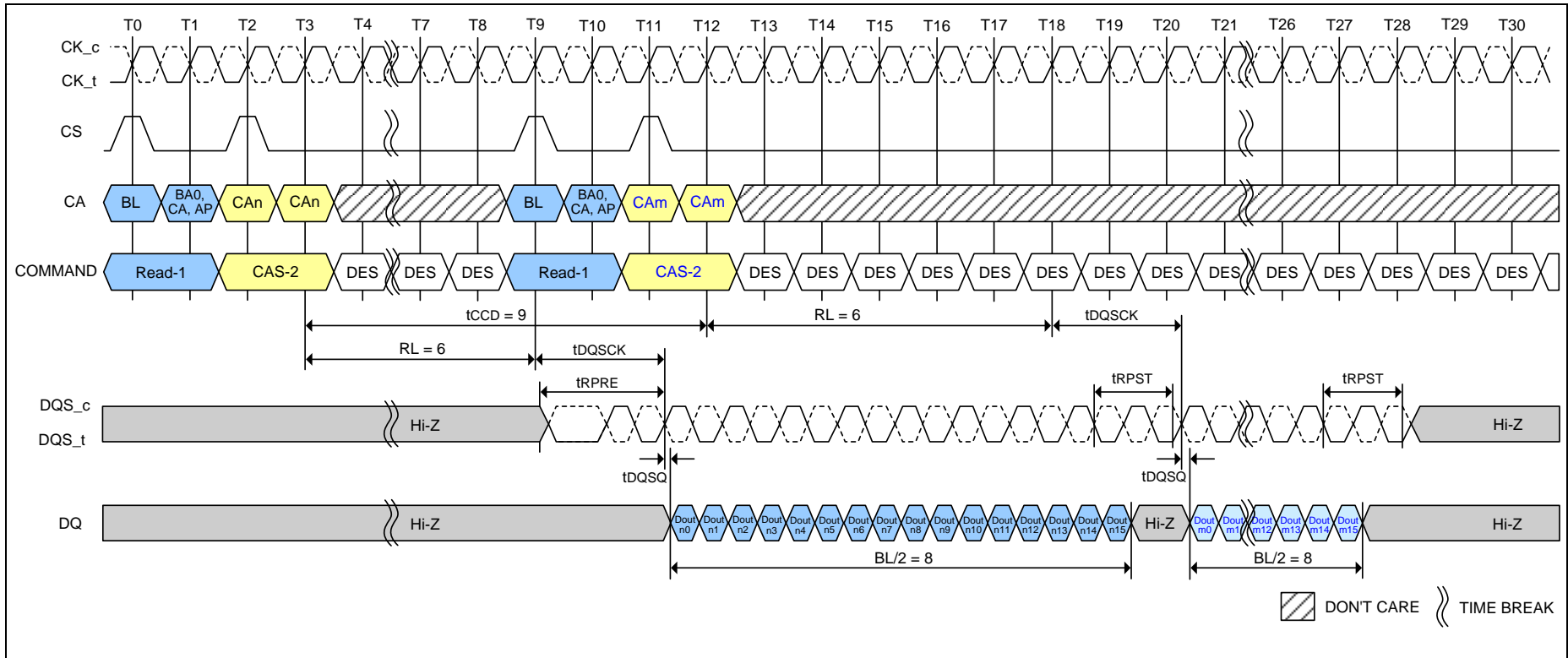

**Notes:**

1. BL = 16 for column n and column m, RL = 6, Preamble = Toggle, Postamble = 1.5nCK.
2. Dout n/m = data-out from column n and column m.
3. DES commands are shown for ease of illustration; other commands may be valid at these times.

**Figure 30 - Consecutive Reads Operation: tCCD = Min +1, Preamble = Toggle, 1.5nCK Postamble**



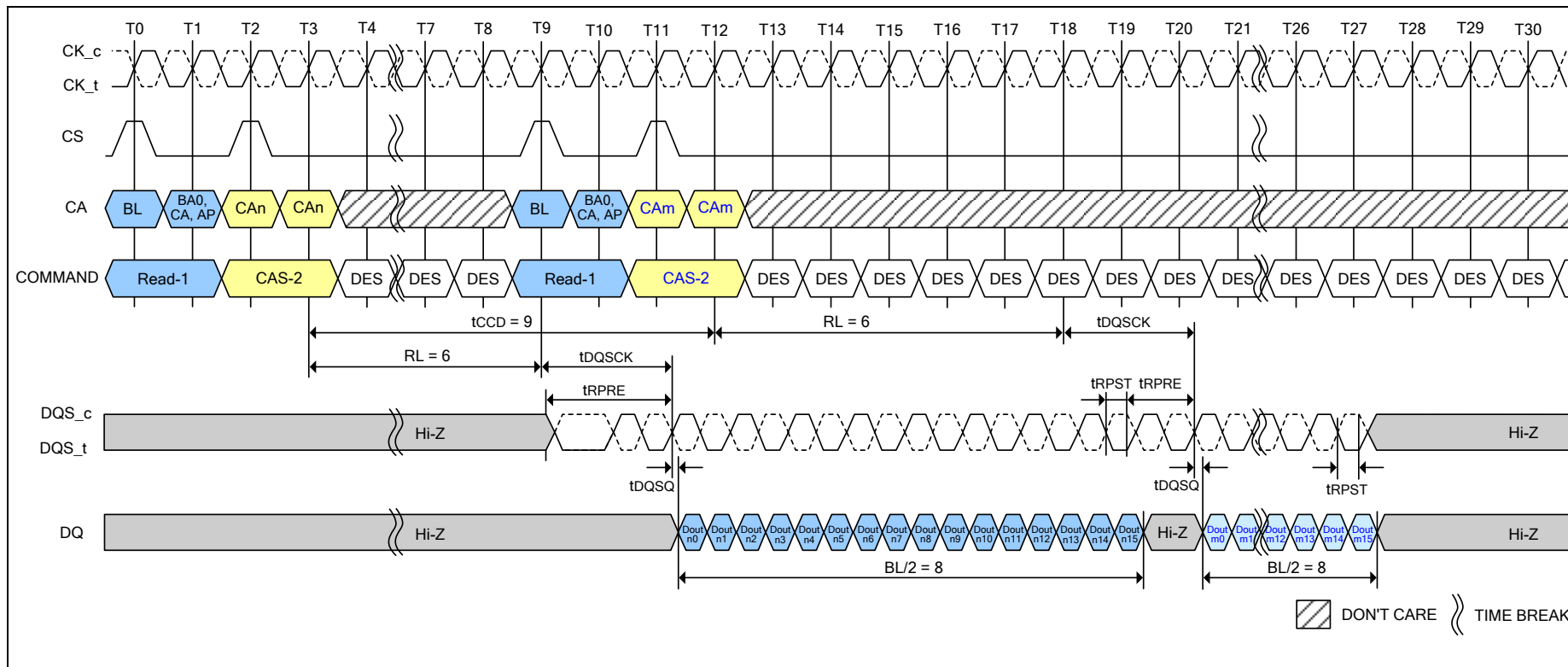

**Notes:**

1. BL = 16 for column n and column m, RL = 6, Preamble = Toggle, Postamble = 0.5nCK.
2. Dout n/m = data-out from column n and column m.
3. DES commands are shown for ease of illustration; other commands may be valid at these times.

**Figure 31 - Consecutive Reads Operation:  $t_{CCD} = \text{Min} + 1$ , Preamble = Toggle, 0.5nCK Postamble**

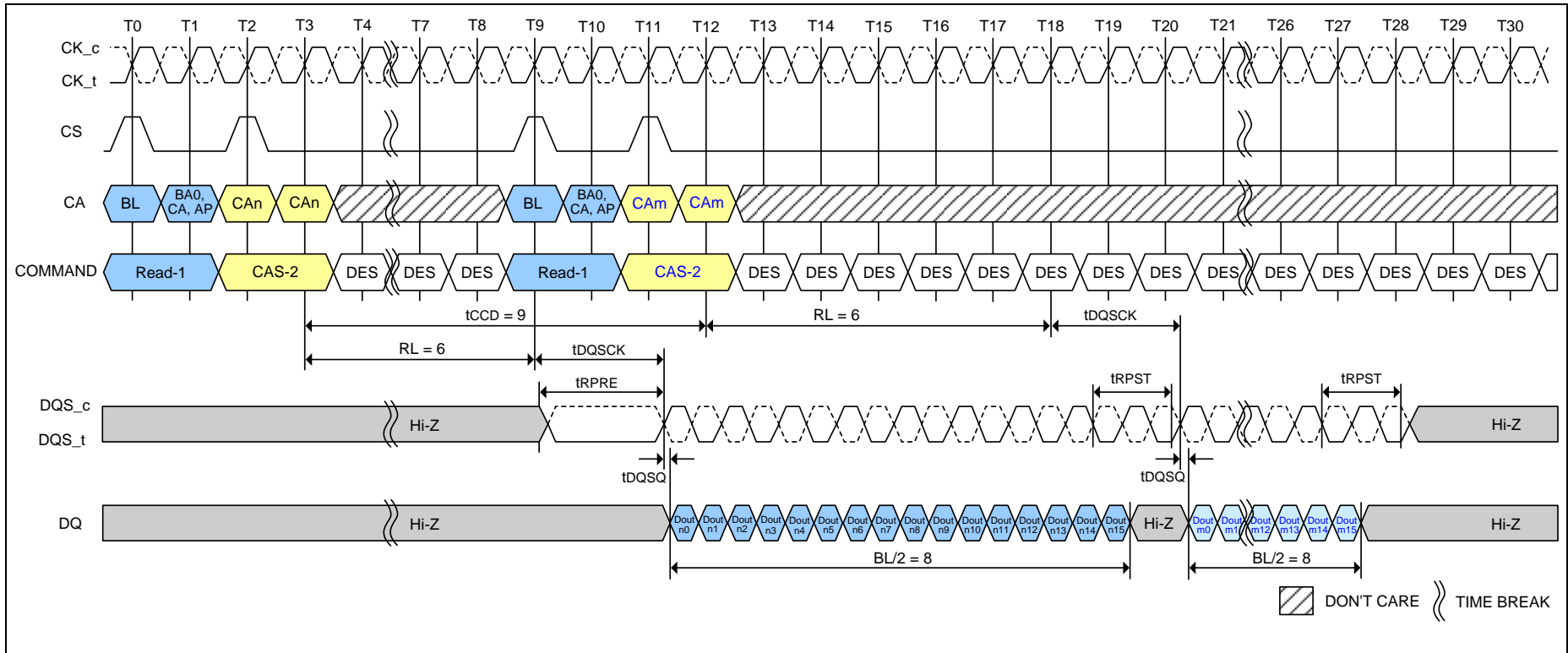

**Notes:**

1. BL = 16 for column n and column m, RL = 6, Preamble = Static, Postamble = 1.5nCK.
2. Dout n/m = data-out from column n and column m.
3. DES commands are shown for ease of illustration; other commands may be valid at these times.

**Figure 32 - Consecutive Reads Operation:  $t_{CCD} = \text{Min} + 1$ , Preamble = Static, 1.5nCK Postamble**

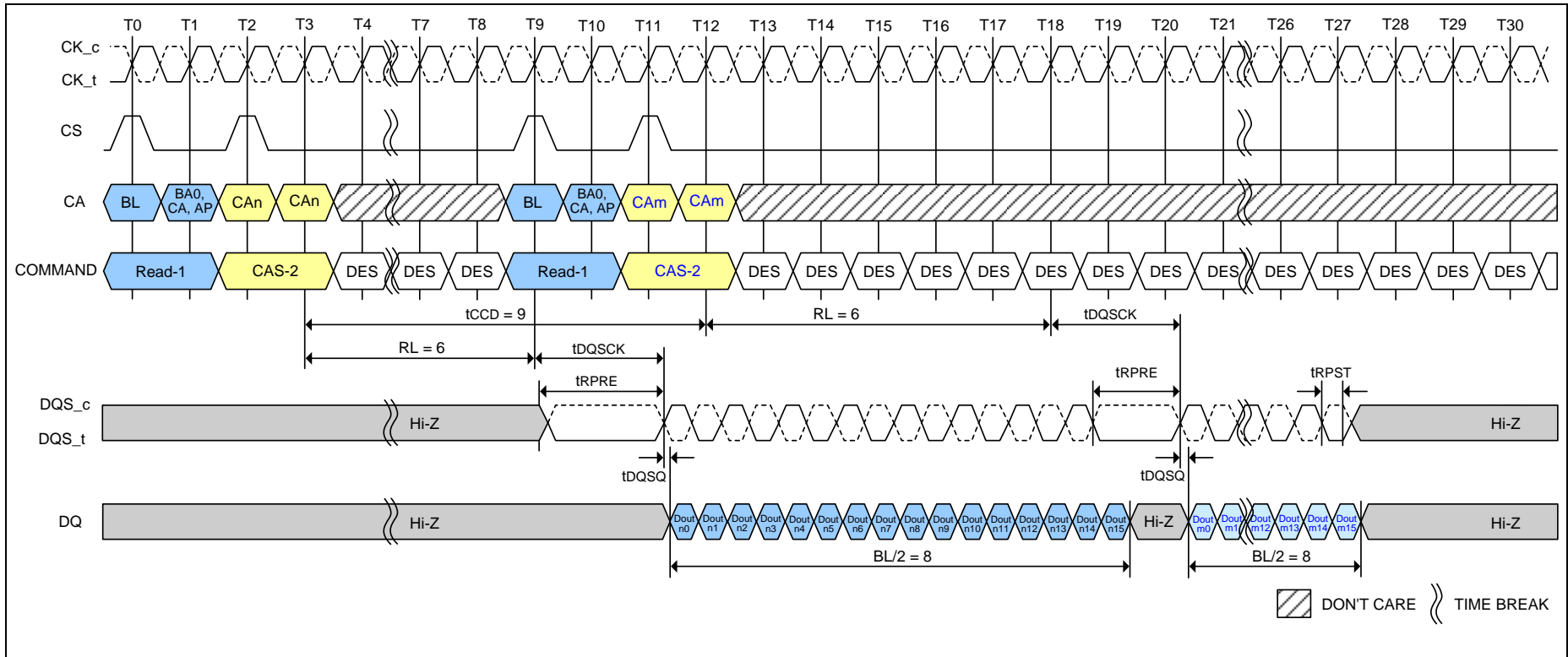

**Notes:**

1. BL = 16 for column n and column m, RL = 6, Preamble = Static, Postamble = 0.5nCK.
2. Dout n/m = data-out from column n and column m.
3. DES commands are shown for ease of illustration; other commands may be valid at these times.

**Figure 33 - Consecutive Reads Operation:  $t_{CCD} = \text{Min} + 1$ , Preamble = Static, 0.5nCK Postamble**

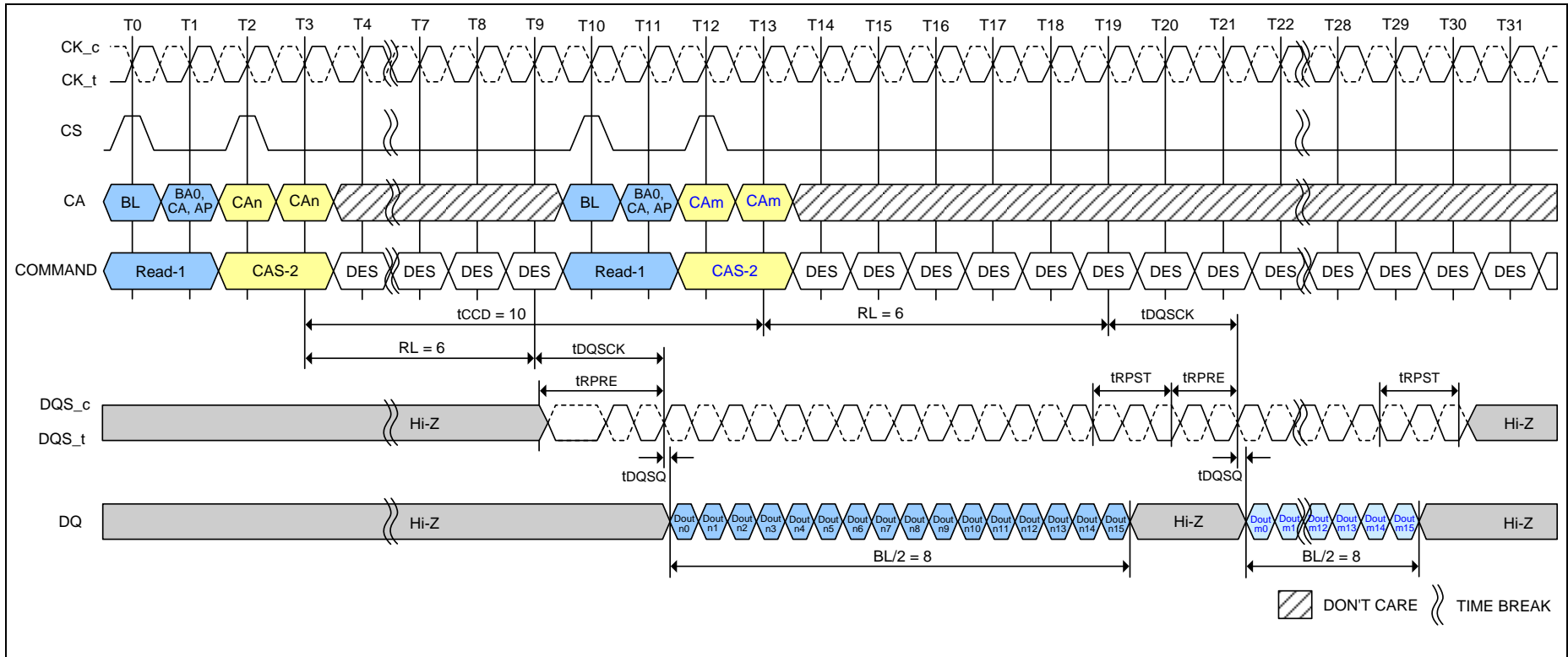

**Notes:**

1. BL = 16 for column n and column m, RL = 6, Preamble = Toggle, Postamble = 1.5nCK.
2. Dout n/m = data-out from column n and column m.
3. DES commands are shown for ease of illustration; other commands may be valid at these times.

**Figure 34 - Consecutive Reads Operation: tCCD = Min +2, Preamble = Toggle, 1.5nCK Postamble**

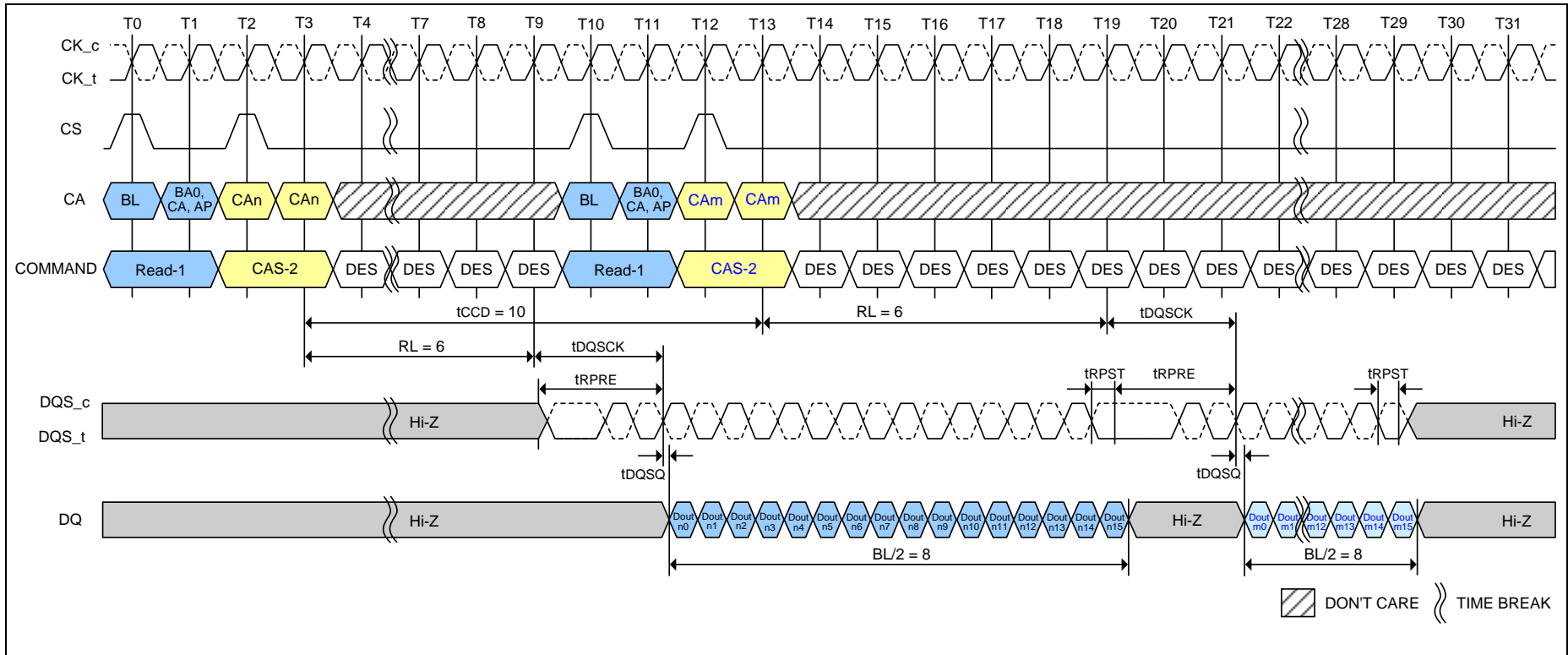

**Notes:**

1. BL = 16 for column n and column m, RL = 6, Preamble = Toggle, Postamble = 0.5nCK.
2. Dout n/m = data-out from column n and column m.
3. DES commands are shown for ease of illustration; other commands may be valid at these times.

**Figure 35 - Consecutive Reads Operation: tCCD = Min +2, Preamble = Toggle, 0.5nCK Postamble**

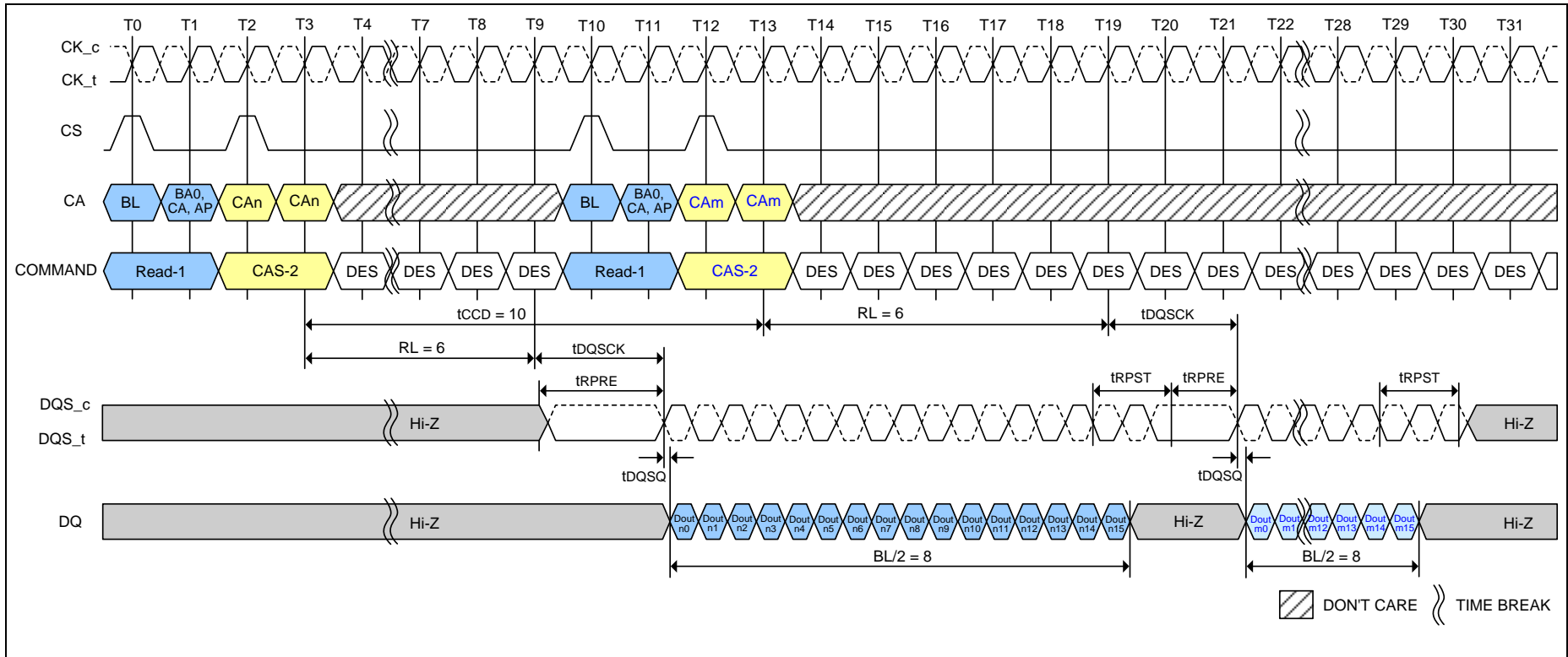

**Notes:**

1. BL = 16 for column n and column m, RL = 6, Preamble = Static, Postamble = 1.5nCK.
2. Dout n/m = data-out from column n and column m.
3. DES commands are shown for ease of illustration; other commands may be valid at these times.

**Figure 36 - Consecutive Reads Operation:  $t_{CCD} = \text{Min} +2$ , Preamble = Static, 1.5nCK Postamble**

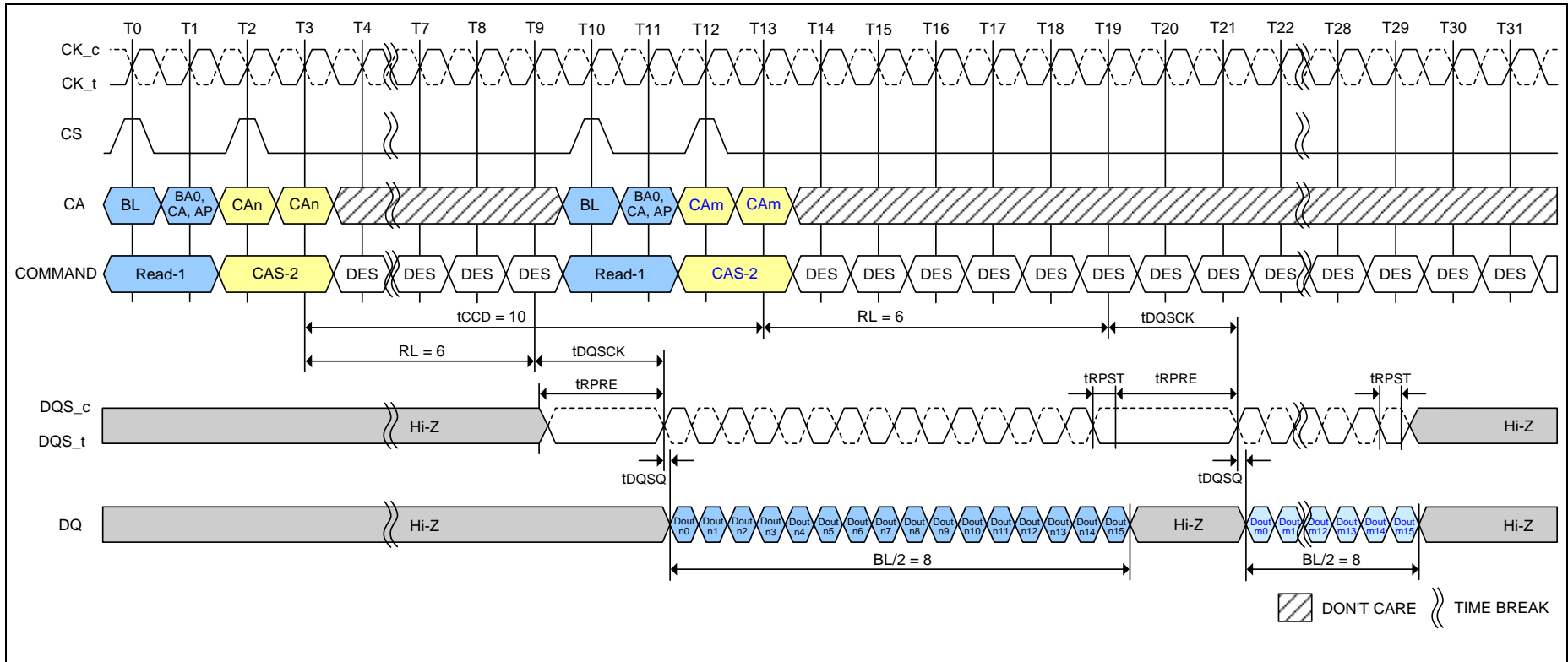

**Notes:**

1. BL = 16 for column n and column m, RL = 6, Preamble = Static, Postamble = 0.5nCK.
2. Dout n/m = data-out from column n and column m.
3. DES commands are shown for ease of illustration; other commands may be valid at these times.

**Figure 37 - Consecutive Reads Operation:  $t_{CCD} = \text{Min} + 2$ , Preamble = Static, 0.5nCK Postamble**

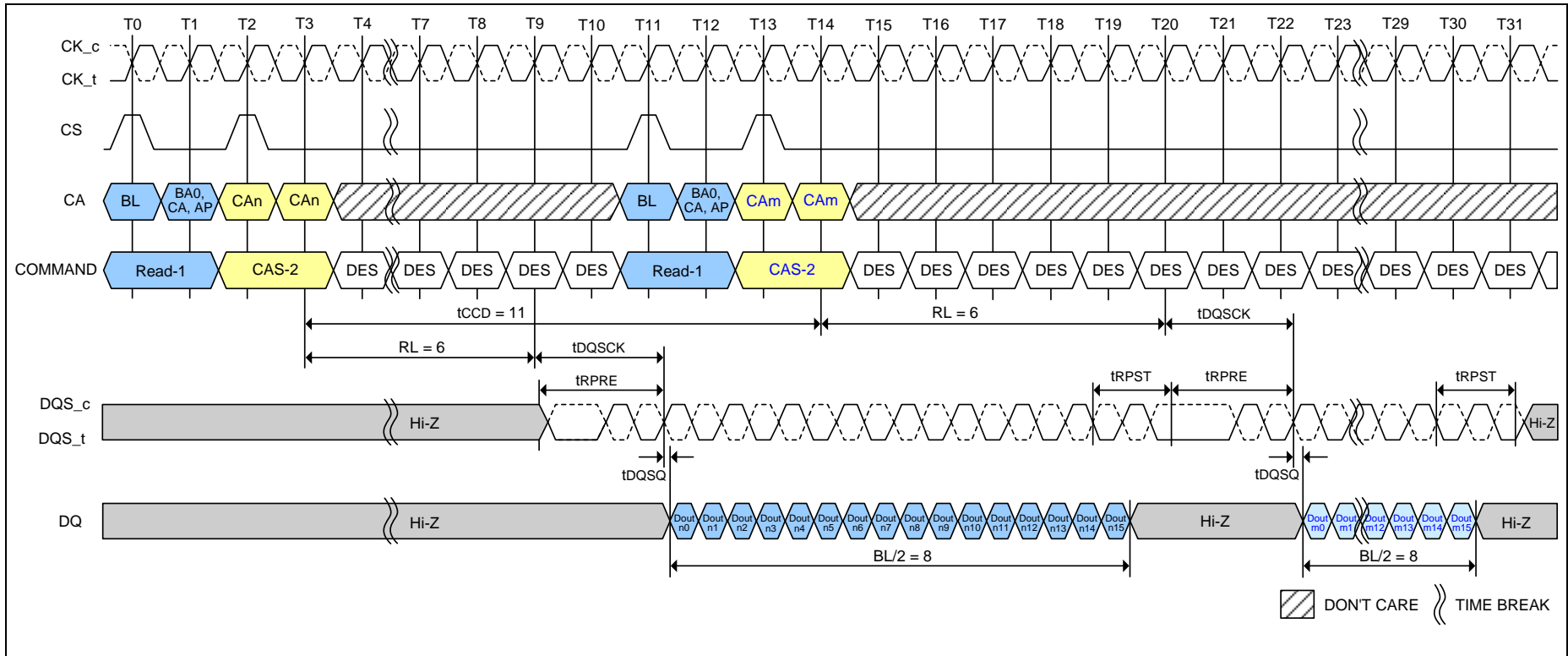

**Notes:**

1. BL = 16 for column n and column m, RL = 6, Preamble = Toggle, Postamble = 1.5nCK.
2. Dout n/m = data-out from column n and column m.
3. DES commands are shown for ease of illustration; other commands may be valid at these times.

**Figure 38 - Consecutive Reads Operation: tCCD = Min +3, Preamble = Toggle, 1.5nCK Postamble**



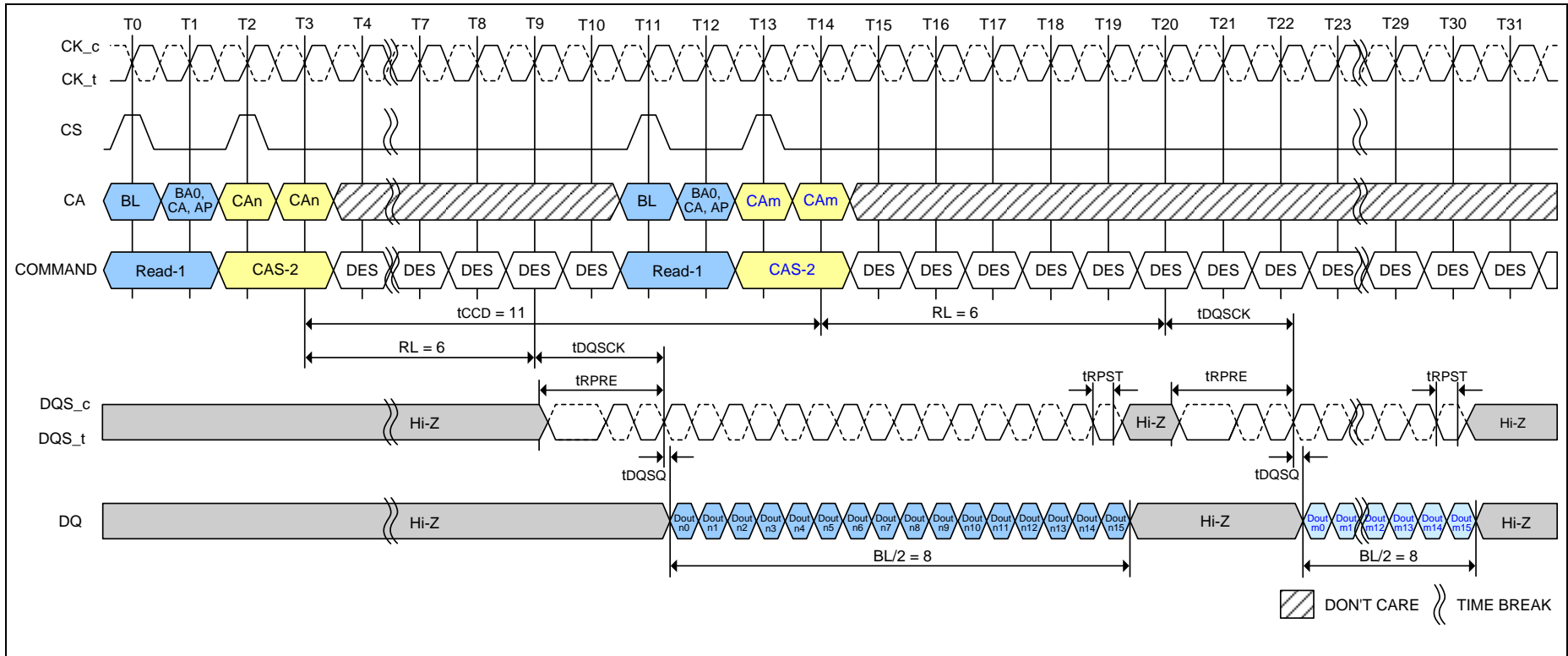

**Notes:**

1. BL = 16 for column n and column m, RL = 6, Preamble = Toggle, Postamble = 0.5nCK.
2. Dout n/m = data-out from column n and column m.
3. DES commands are shown for ease of illustration; other commands may be valid at these times.

**Figure 39 - Consecutive Reads Operation: tCCD = Min +3, Preamble = Toggle, 0.5nCK Postamble**

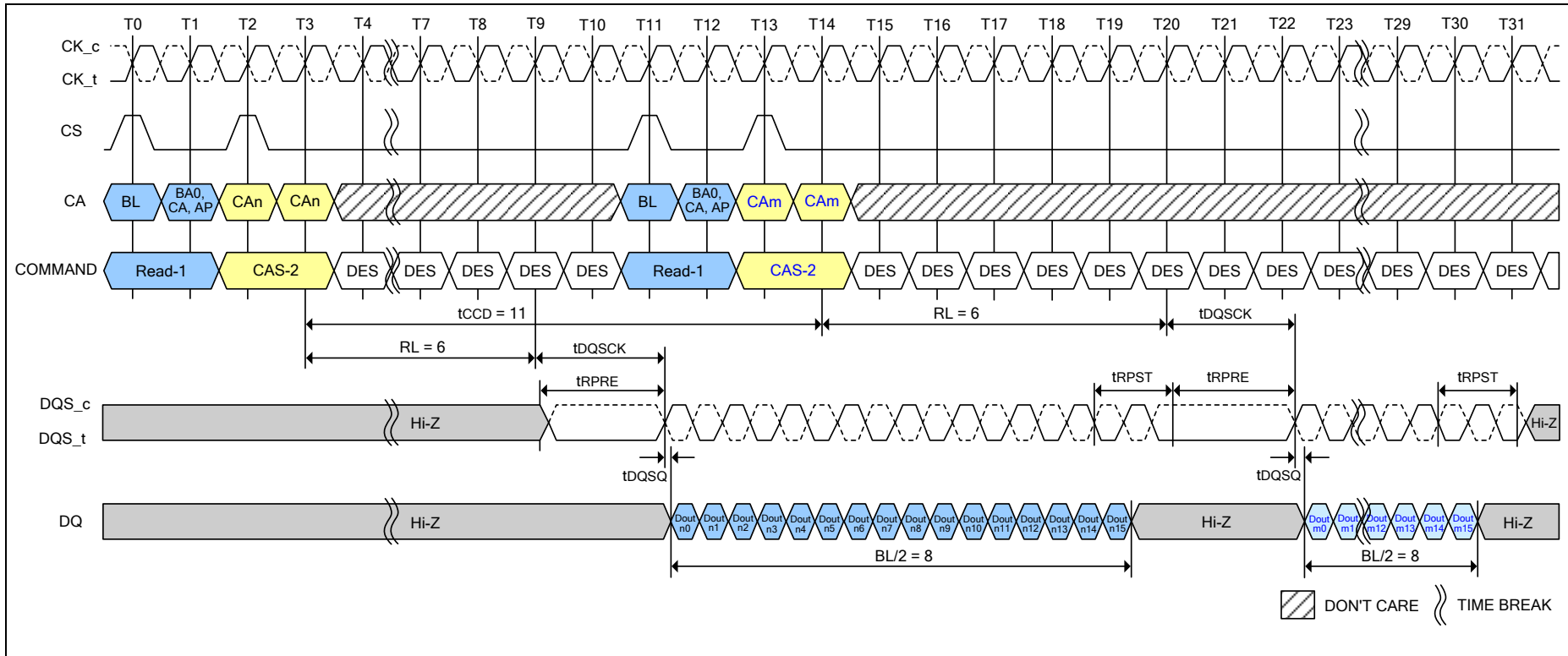

**Notes:**

1. BL = 16 for column n and column m, RL = 6, Preamble = Static, Postamble = 1.5nCK.
2. Dout n/m = data-out from column n and column m.
3. DES commands are shown for ease of illustration; other commands may be valid at these times.

**Figure 40 - Consecutive Reads Operation: tCCD = Min +3, Preamble = Static, 1.5nCK Postamble**

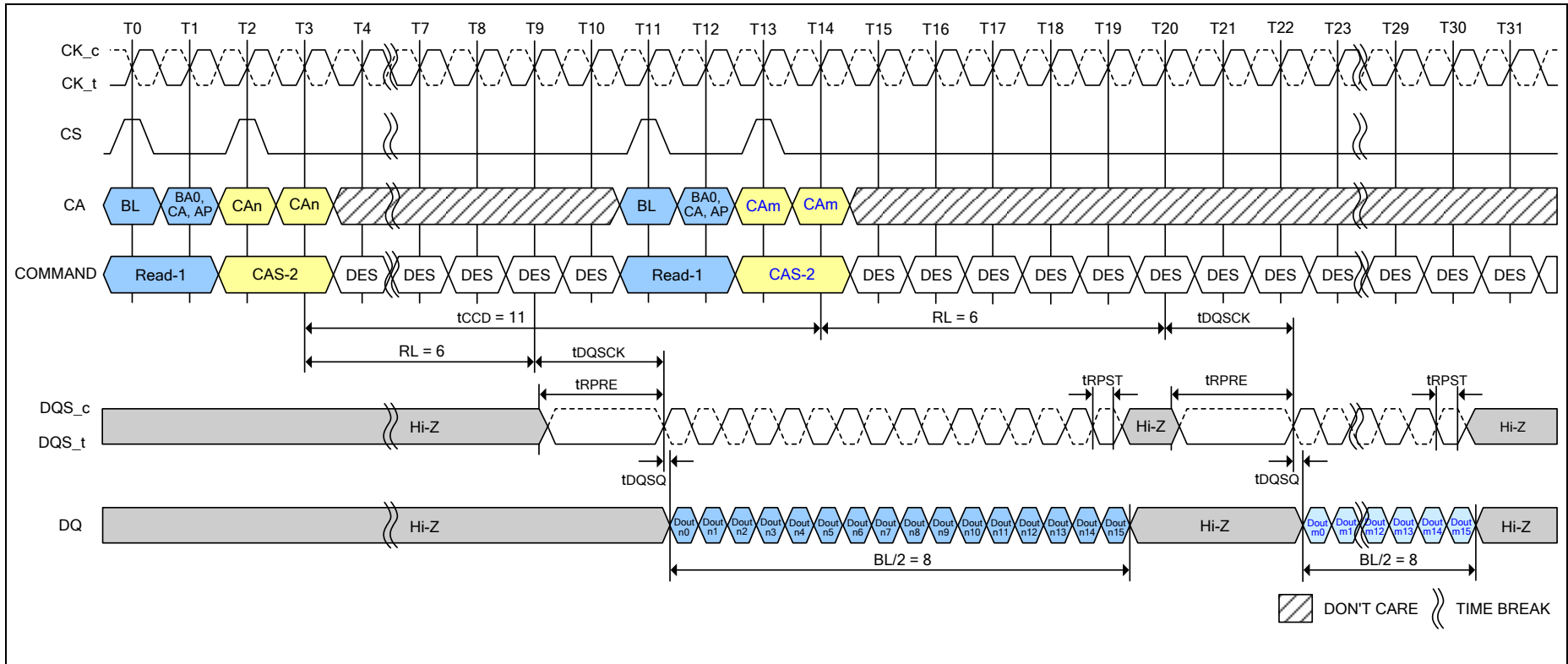

**Notes:**

1. BL = 16 for column n and column m, RL = 6, Preamble = Static, Postamble = 0.5nCK.
2. Dout n/m = data-out from column n and column m.
3. DES commands are shown for ease of illustration; other commands may be valid at these times.

**Figure 41 - Consecutive Reads Operation: tCCD = Min +3, Preamble = Static, 0.5nCK Postamble**



7.4.14.2 Write to Write Operation

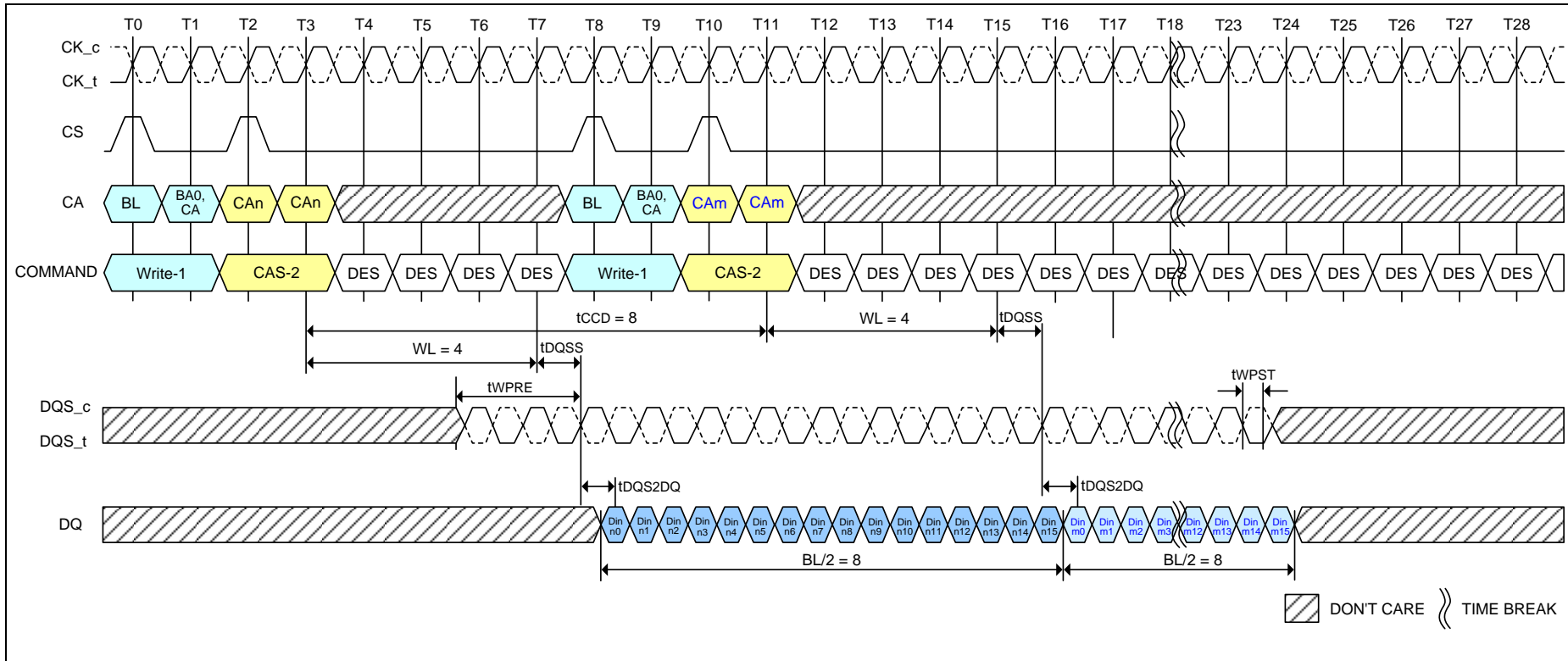

Notes:

1. BL=16, Write Postamble = 0.5nCK.
2. Dout n/m = data-in to column n and column m.
3. The minimum number of clock cycles from the burst write command to the burst write command for any bank is BL/2.
4. DES commands are shown for ease of illustration; other commands may be valid at these times.

Figure 42 - Seamless Writes Operation: tCCD = Min, 0.5nCK Postamble

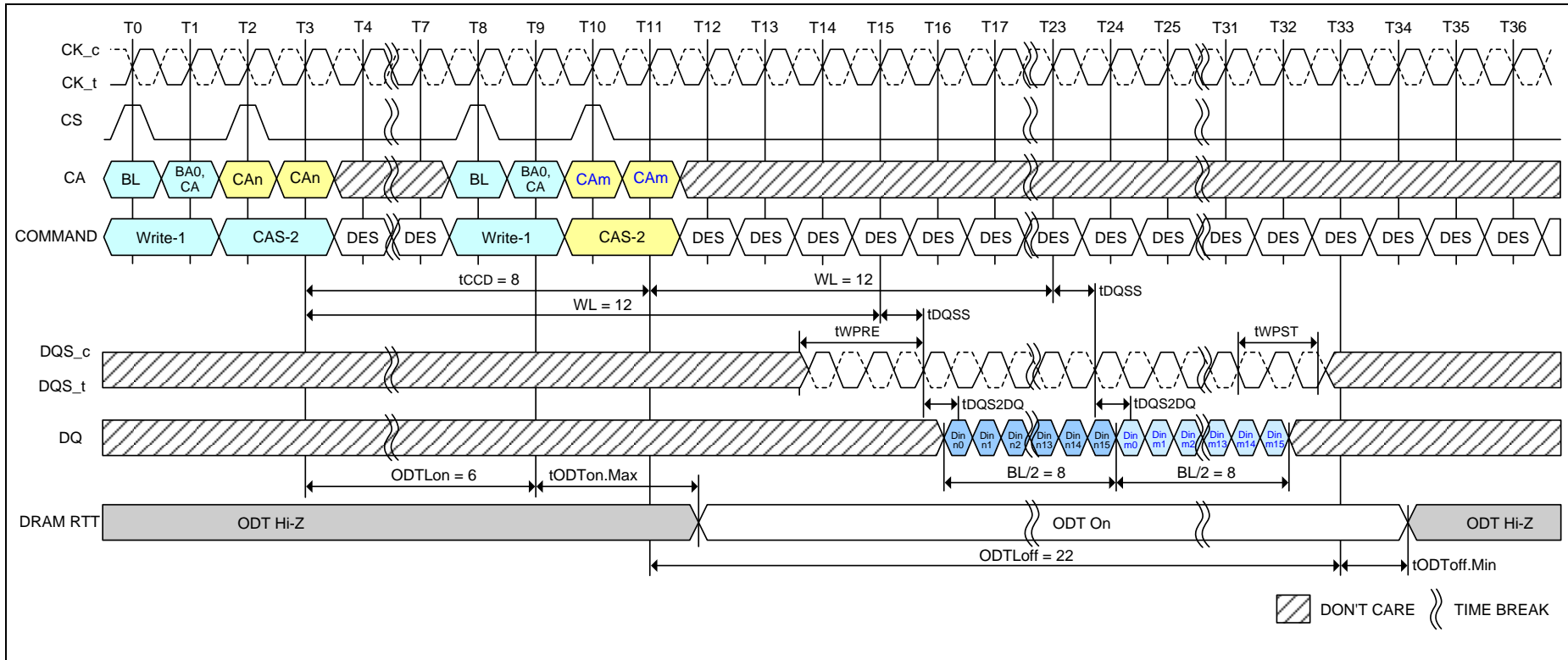

**Notes:**

1. Clock Frequency = 800MHz,  $t_{CK(AVG)} = 1.25nS$ .
2. BL=16, Write Postamble = 1.5nCK.
3. Dout n/m = data-in to column n and column m.
4. The minimum number of clock cycles from the burst write command to the burst write command for any bank is BL/2.
5. DES commands are shown for ease of illustration; other commands may be valid at these times.

**Figure 43 - Seamless Writes Operation:  $t_{CCD} = \text{Min}$ , 1.5nCK Postamble, 533MHz < Clock Freq. ≤ 800MHz, ODT Worst Timing Case**

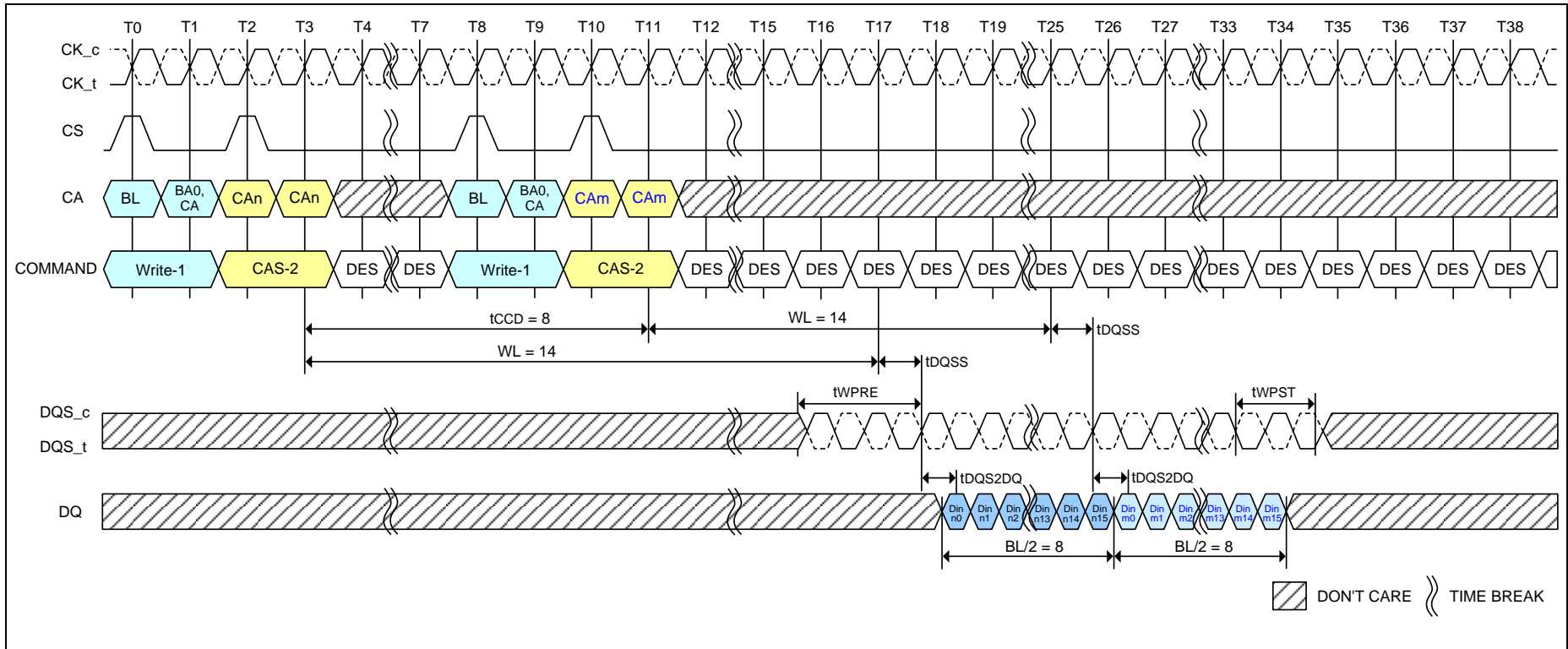

**Notes:**

1. BL=16, Write Postamble = 1.5nCK.
2. Dout n/m = data-in to column n and column m.
3. The minimum number of clock cycles from the burst write command to the burst write command for any bank is BL/2.
4. DES commands are shown for ease of illustration; other commands may be valid at these times.

**Figure 44 - Seamless Writes Operation: tCCD = Min, 1.5nCK Postamble**

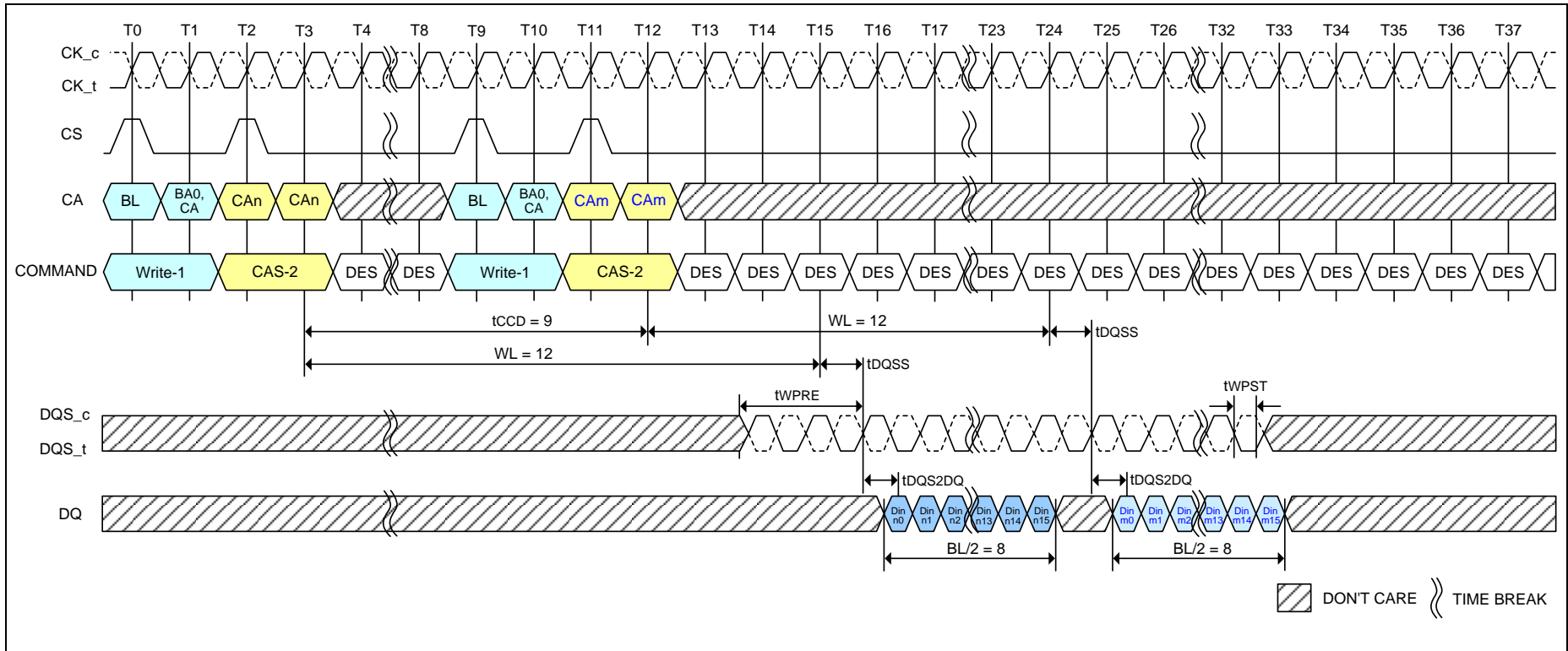

**Notes:**

1. BL=16, Write Postamble = 0.5nCK.
2. Dout n/m = data-in to column n and column m.
3. DES commands are shown for ease of illustration; other commands may be valid at these times.

**Figure 45 - Consecutive Writes Operation: tCCD = Min + 1, 0.5nCK Postamble**

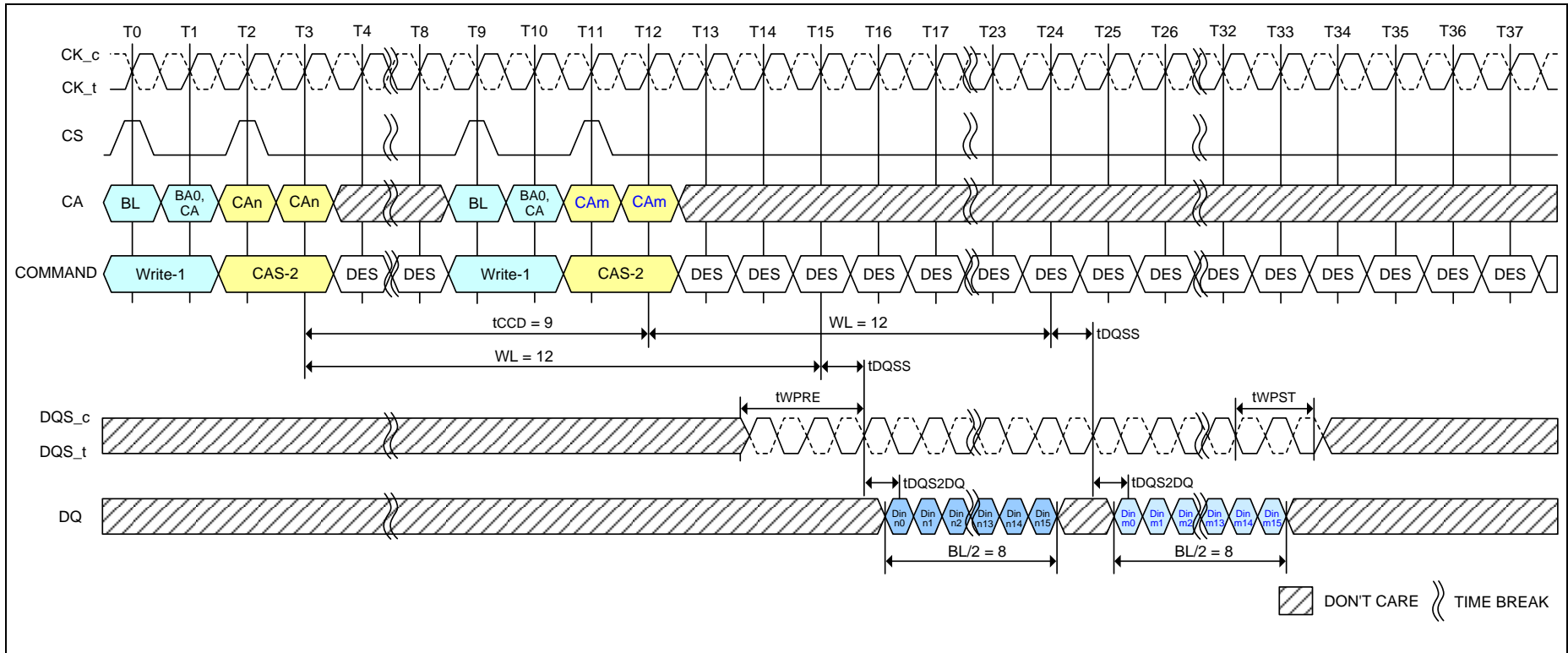

**Notes:**

1. BL=16, Write Postamble = 1.5nCK.
2. Dout n/m = data-in to column n and column m.
3. DES commands are shown for ease of illustration; other commands may be valid at these times.

**Figure 46 - Consecutive Writes Operation: tCCD = Min + 1, 1.5nCK Postamble**



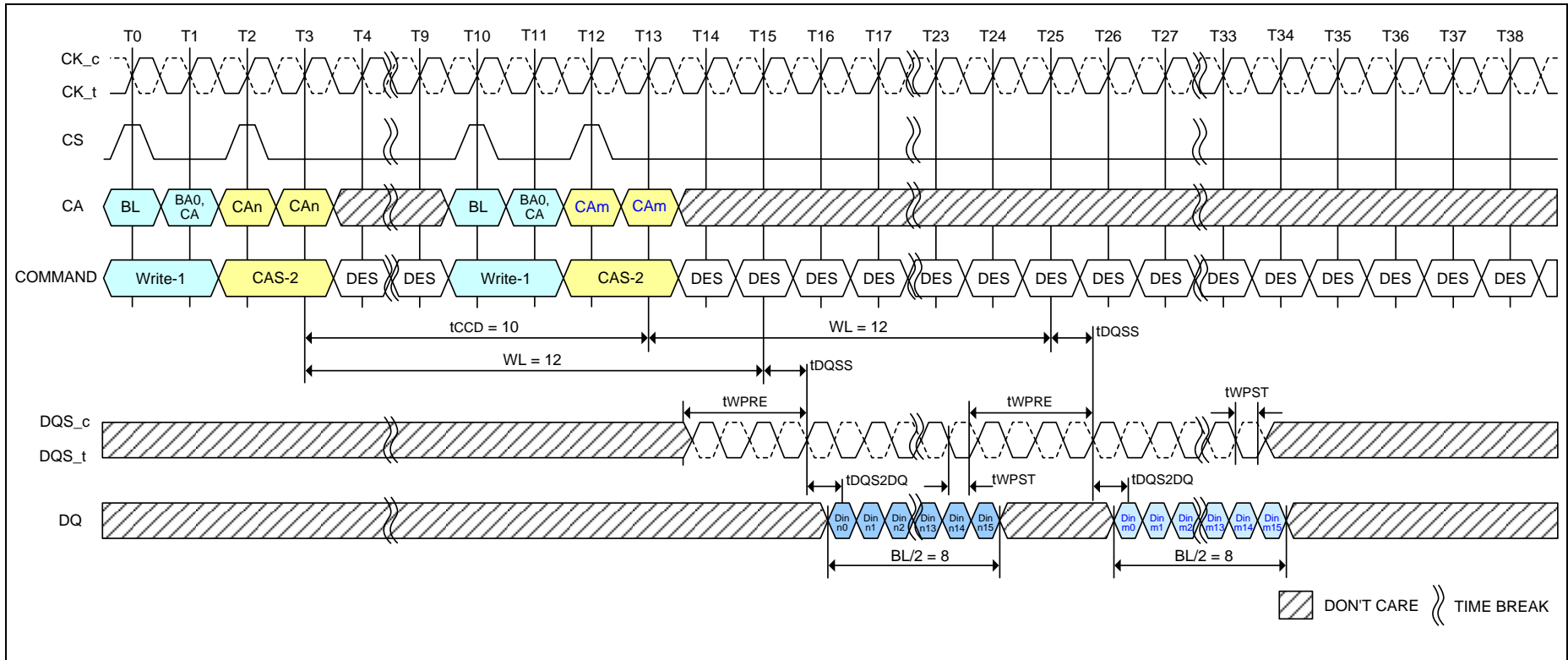

**Notes:**

1. BL=16, Write Postamble = 0.5nCK.
2. Dout n/m = data-in to column n and column m.
3. DES commands are shown for ease of illustration; other commands may be valid at these times.

**Figure 47 - Consecutive Writes Operation: tCCD = Min + 2, 0.5nCK Postamble**

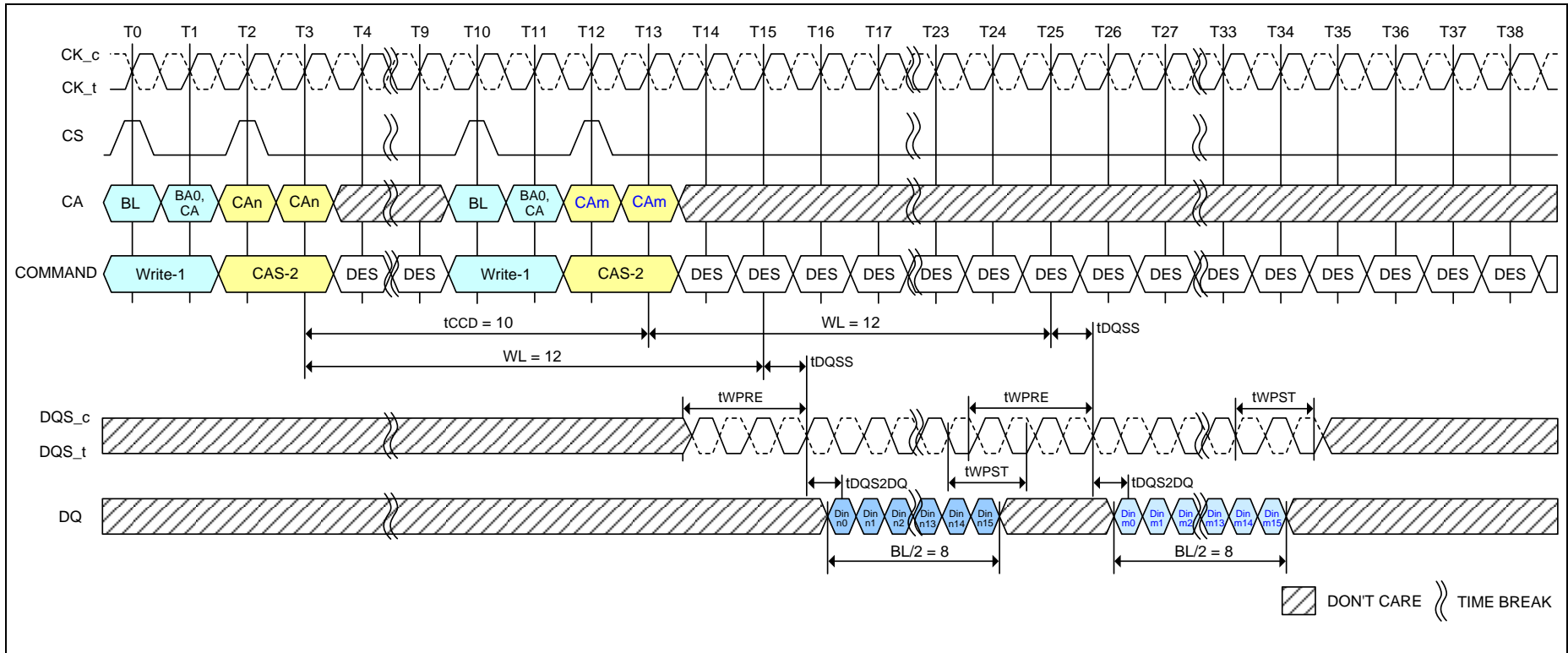

**Notes:**

1.  $BL=16$ , Write Postamble =  $1.5nCK$ .
2. Dout  $n/m$  = data-in to column  $n$  and column  $m$ .
3. DES commands are shown for ease of illustration; other commands may be valid at these times.

**Figure 48 - Consecutive Writes Operation:  $t_{CCD} = \text{Min} + 2, 1.5nCK$  Postamble**

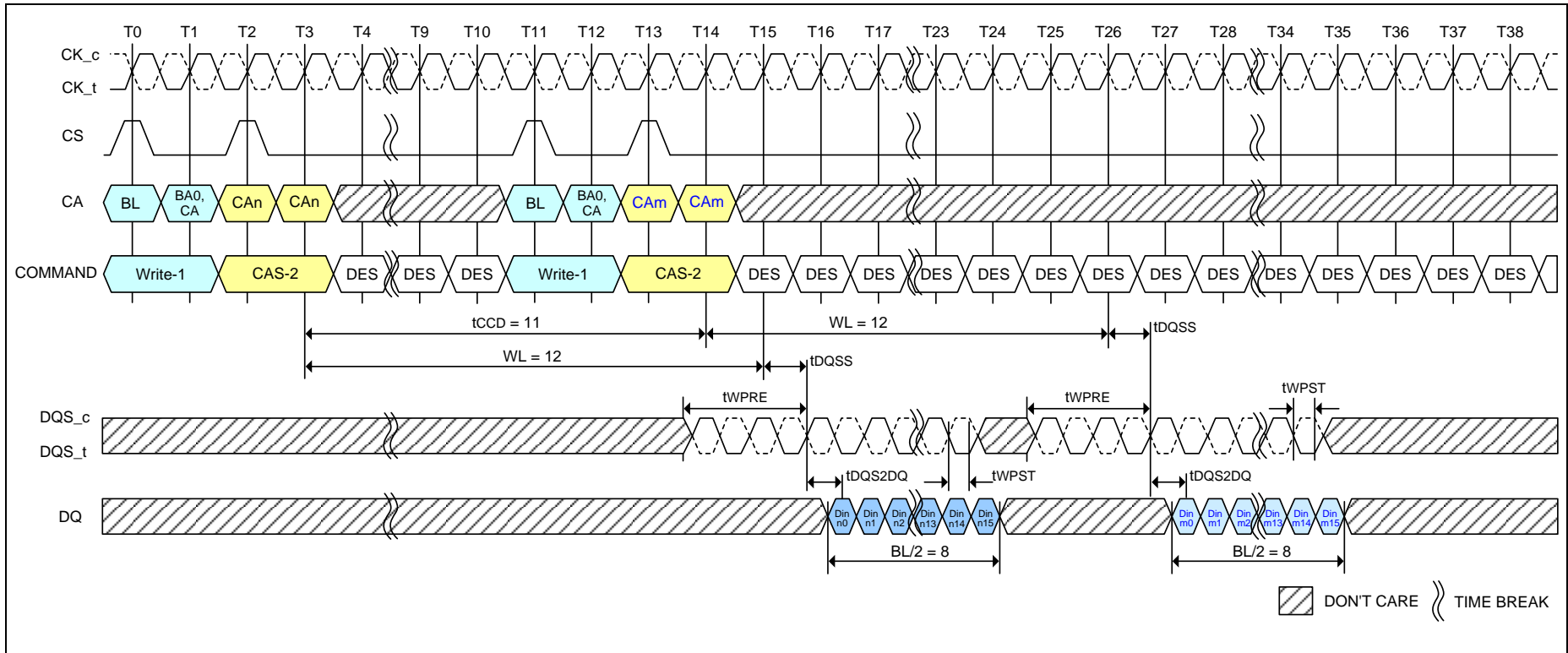

**Notes:**

1. BL=16, Write Postamble = 0.5nCK.
2. Dout n/m = data-in to column n and column m.
3. DES commands are shown for ease of illustration; other commands may be valid at these times.

**Figure 49 - Consecutive Writes Operation: tCCD = Min + 3, 0.5nCK Postamble**

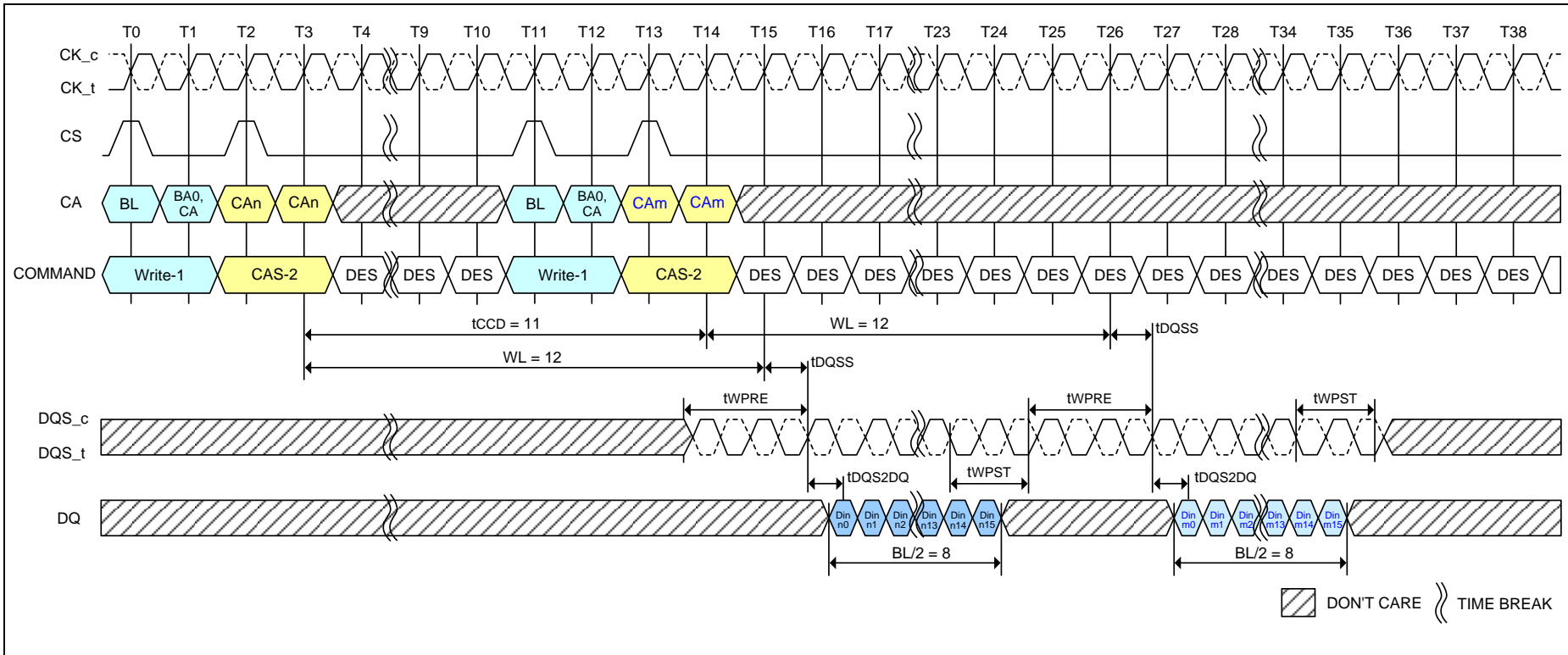

**Notes:**

1.  $BL=16$ , Write Postamble =  $1.5nCK$ .
2. Dout n/m = data-in to column n and column m.
3. DES commands are shown for ease of illustration; other commands may be valid at these times.

**Figure 50 - Consecutive Writes Operation:  $t_{CCD} = \text{Min} + 3, 1.5nCK$  Postamble**

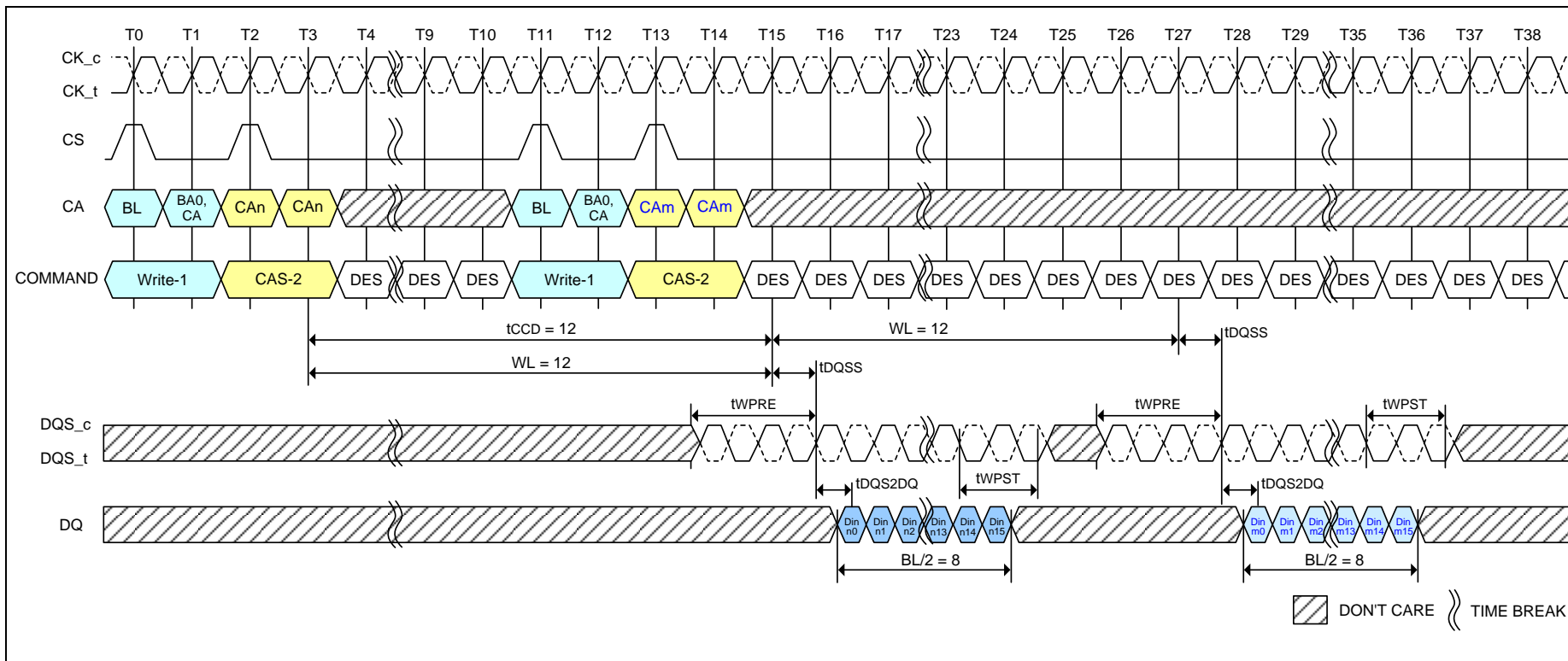

**Notes:**

1. BL=16, Write Postamble = 1.5nCK.
2. Dout n/m = data-in to column n and column m.
3. DES commands are shown for ease of illustration; other commands may be valid at these times.

**Figure 51 - Consecutive Writes Operation: tCCD = Min + 4, 1.5nCK Postamble**



**7.4.15 Masked Write Operation**

The LPDDR4X-SDRAM requires that Write operations which include a byte mask anywhere in the burst sequence must use the Masked Write command. This allows the DRAM to implement efficient data protection schemes based on larger data blocks. The Masked Write-1 command is used to begin the operation, followed by a CAS-2 command.

A Masked Write command to the same bank cannot be issued until  $t_{CCDMW}$  later, to allow the LPDDR4X-SDRAM to finish the internal Read-Modify-Write. One Data Mask-Invert (DMI) pin is provided per byte lane, and the Data Mask-Invert timings match data bit (DQ) timing. See the section on “Data Mask Invert” for more information on the use of the DMI signal.

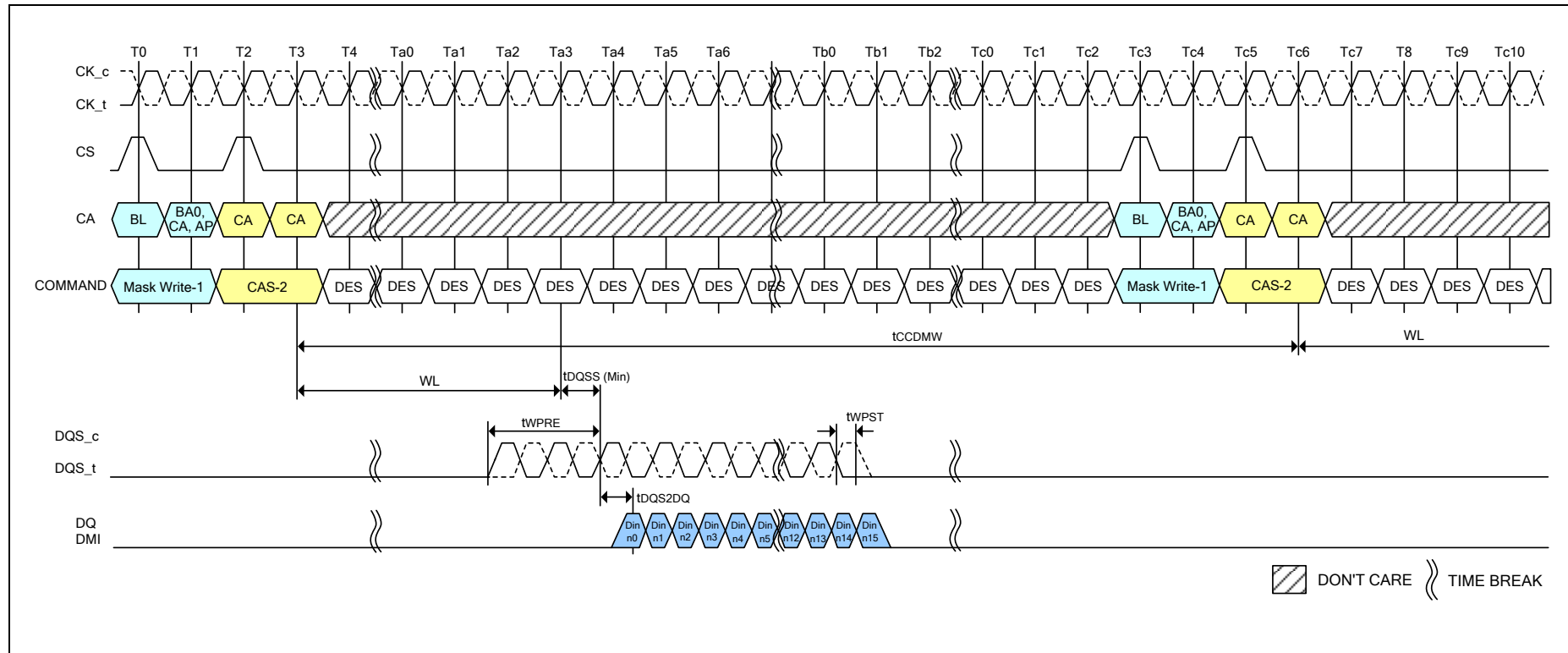

**Notes:**

1. BL=16, Write Postamble = 0.5nCK, DQ/DQS: VSSQ termination.
2. Din n = data-in to column n.
3. Mask-Write supports only BL16 operations. For BL32 configuration, the system needs to insert only 16 bit wide data for masked write operation.
4. DES commands are shown for ease of illustration; other commands may be valid at these times.

**Figure 52 - Masked Write Command - Same Bank**

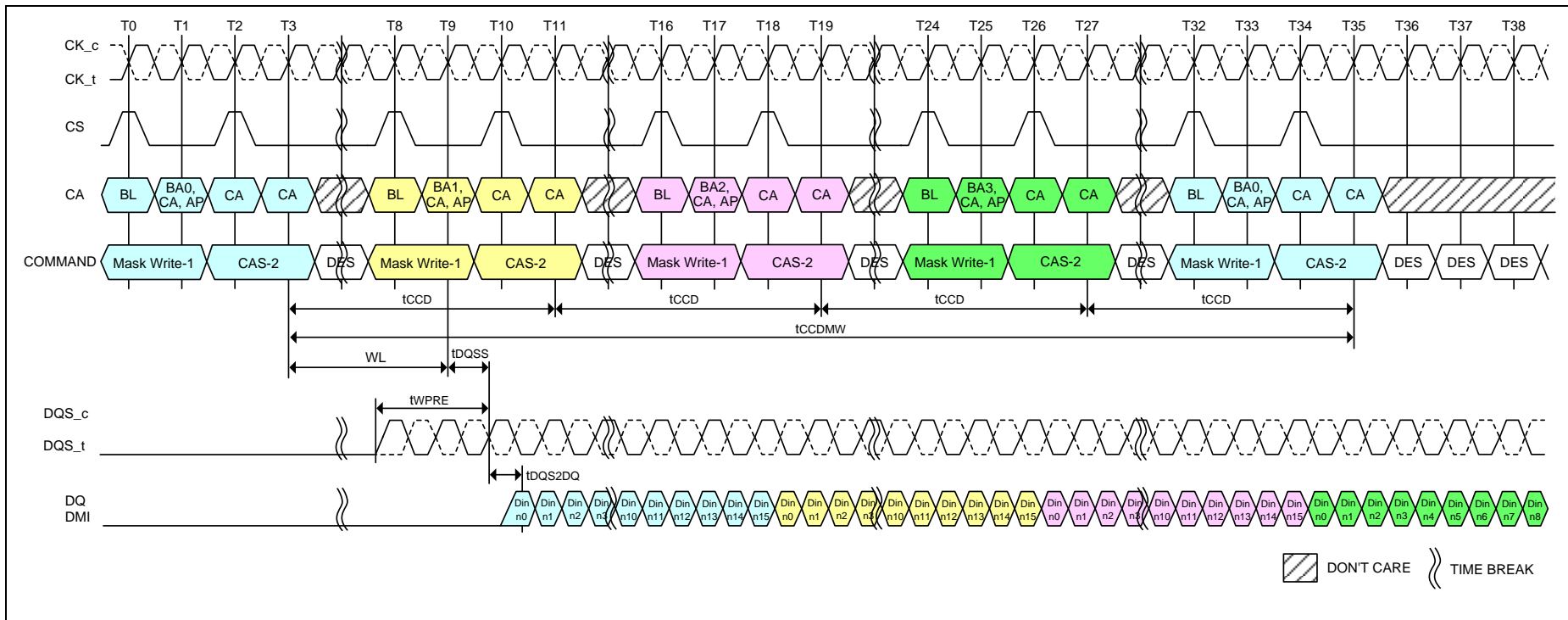

- Notes:**
1. BL=16, DQ/DQS/DMI: VSSQ termination.
  2. Din n = data-in to column n.
  3. Mask-Write supports only BL16 operations. For BL32 configuration, the system needs to insert only 16 bit wide data for masked write operation.
  4. DES commands are shown for ease of illustration; other commands may be valid at these times.

**Figure 53 - Masked Write Command - Different Bank**



## 7.4.15.1 Masked Write Timing constraints for BL16

Table 29 - Timing constraints for same bank: DQ ODT is Disabled

Next CMD Current CMD	Active	Read (BL=16 or 32)	Write (BL=16 or 32)	Masked Write	Precharge
Active	illegal	RU(tRCD/tCK)	RU(tRCD/tCK)	RU(tRCD/tCK)	RU(tRAS/tCK)
Read with BL = 16	illegal	8* <sup>1</sup>	RL+RU(tDQSK(max)/tCK) + BL/2-WL+tWPRE+RD(tRPST)	RL+RU(tDQSK(max)/tCK) + BL/2-WL+tWPRE+RD(tRPST)	BL/2+max{(8,RU(tRTP/tCK))-8}
Read with BL = 32	illegal	16* <sup>2</sup>	RL+RU(tDQSK(max)/tCK) + BL/2-WL+tWPRE+RD(tRPST)	RL+RU(tDQSK(max)/tCK) + BL/2-WL+tWPRE+RD(tRPST)	BL/2+max{(8,RU(tRTP/tCK))-8}
Write with BL = 16	illegal	WL+1+BL/2 +RU(tWTR/tCK)	8* <sup>1</sup>	tCCDMW* <sup>3</sup>	WL+ 1 + BL/2+RU(tWR/tCK)
Write with BL = 32	illegal	WL+1+BL/2 +RU(tWTR/tCK)	16* <sup>2</sup>	tCCDMW +8* <sup>4</sup>	WL+ 1 + BL/2+RU(tWR/tCK)
Masked Write	illegal	WL+1+BL/2 +RU(tWTR/tCK)	tCCD	tCCDMW* <sup>3</sup>	WL+ 1 + BL/2+RU(tWR/tCK)
Precharge	RU(tRP/tCK), RU(tRPab/tCK)	illegal	illegal	illegal	4

**Notes:**

1. In the case of BL = 16, tCCD is 8\*tCK.
2. In the case of BL = 32, tCCD is 16\*tCK.
3. tCCDMW = 32\*tCK (4\*tCCD at BL=16)
4. Write with BL=32 operation has 8\*tCK longer than BL =16.
5. tRPST values depend on MR1-OP[7] respectively.

Table 30 - Timing constraints for same bank: DQ ODT is Enabled

Next CMD Current CMD	Active	Read (BL=16 or 32)	Write (BL=16 or 32)	Masked Write	Precharge
Read with BL = 16	illegal	8* <sup>1</sup>	RL+RU(tDQSK(max)/ tCK)+BL/2+RD(tRPST)- ODTLon-RD(tODTon,min/tCK)+1	RL+RU(tDQSK(max)/ tCK)+BL/2+RD(tRPST)- ODTLon-RD(tODTon,min/tCK)+1	BL/2+max{(8,RU(tRTP/tCK))-8}
Read with BL = 32	illegal	16* <sup>2</sup>	RL+RU(tDQSK(max)/ tCK)+BL/2+RD(tRPST)- ODTLon-RD(tODTon,min/tCK)+1	RL+RU(tDQSK(max)/ tCK)+BL/2+RD(tRPST)- ODTLon-RD(tODTon,min/tCK)+1	BL/2+max{(8,RU(tRTP/tCK))-8}

**Notes:**

1. In the case of BL = 16, tCCD is 8\*tCK.
2. In the case of BL = 32, tCCD is 16\*tCK.
3. The rest of the timing is same as DQ ODT is Disable case.
4. tRPST values depend on MR1-OP[7] respectively.





Table 31 - Timing constraints for Different bank: DQ ODT is Disabled

Next CMD Current CMD	Active	Read (BL=16 or 32)	Write (BL=16 or 32)	Masked Write	Precharge
Active	RU(tRRD/tCK)	4	4	4	2
Read with BL = 16	4	8* <sup>1</sup>	RL+RU(tDQSK(max)/tCK) + BL/2-WL+tWPRE+RD(tRPST)	RL+RU(tDQSK(max)/tCK) + BL/2-WL+tWPRE+RD(tRPST)	2
Read with BL = 32	4	16* <sup>2</sup>	RL+RU(tDQSK(max)/tCK) + BL/2-WL+tWPRE+RD(tRPST)	RL+RU(tDQSK(max)/tCK) + BL/2-WL+tWPRE+RD(tRPST)	2
Write with BL = 16	4	WL+1+BL/2 +RU(tWTR/tCK)	8* <sup>1</sup>	8* <sup>1</sup>	2
Write with BL = 32	4	WL+1+BL/2 +RU(tWTR/tCK)	16* <sup>2</sup>	16* <sup>2</sup>	2
Masked Write	4	WL+1+BL/2 +RU(tWTR/tCK)	8* <sup>1</sup>	8* <sup>1</sup>	2
Precharge	4	4	4	4	4

**Notes:**

1. In the case of BL = 16, tCCD is 8\*tCK.
2. In the case of BL = 32, tCCD is 16\*tCK.
3. tRPST values depend on MR1-OP[7] respectively.

Table 32 - Timing constraints for Different bank: DQ ODT is Enabled

Next CMD Current CMD	Active	Read (BL=16 or 32)	Write (BL=16 or 32)	Masked Write	Precharge
Read with BL = 16	4	8* <sup>1</sup>	RL+RU(tDQSK(max)/ tCK)+BL/2+RD(tRPST)- ODTLon-RD(tODTon,min/tCK)+1	RL+RU(tDQSK(max)/ tCK)+BL/2+RD(tRPST)- ODTLon-RD(tODTon,min/tCK)+1	2
Read with BL = 32	4	16* <sup>2</sup>	RL+RU(tDQSK(max)/ tCK)+BL/2+RD(tRPST)- ODTLon-RD(tODTon,min/tCK)+1	RL+RU(tDQSK(max)/ tCK)+BL/2+RD(tRPST)- ODTLon-RD(tODTon,min/tCK)+1	2

**Notes:**

1. In the case of BL = 16, tCCD is 8\*tCK.
2. In the case of BL = 32, tCCD is 16\*tCK.
3. The rest of the timing is same as DQ ODT is Disable case.
4. tRPST values depend on MR1-OP[7] respectively.



#### 7.4.16 LPDDR4X Data Mask (DM) and Data Bus Inversion (DBI<sub>dc</sub>) Function

LPDDR4X SDRAM supports the function of Data Mask and Data Bus inversion. Its details are shown below.

- LPDDR4X device supports Data Mask (DM) function for Write operation.
- LPDDR4X device supports Data Bus Inversion (DBI<sub>dc</sub>) function for Write and Read operation.
- LPDDR4X supports DM and DBI<sub>dc</sub> function with a byte granularity.
- DBI<sub>dc</sub> function during Write or Masked Write can be enabled or disabled through MR3 OP[7].
- DBI<sub>dc</sub> function during Read can be enabled or disabled through MR3 OP[6].
- DM function during Masked Write can be enabled or disabled through MR13 OP[5].
- LPDDR4X device has one Data Mask Inversion (DMI) signal pin per byte; total of 2 DMI signals per channel.
- DMI signal is a bi-directional DDR signal and is sampled along with the DQ signals for Read and Write or Masked Write operation.

There are eight possible combinations for LPDDR4X device with DM and DBI<sub>dc</sub> function. The table below describes the functional behavior for all combinations.

**Table 33 - Function Behavior of DMI Signal during Write, Masked Write and Read Operation**

DM Function	Write DBI <sub>dc</sub> Function	Read DBI <sub>dc</sub> Function	DMI Signal during Write Command	DMI Signal during Masked Write Command	DMI Signal During Read	DMI Signal during MPC WR FIFO	DMI Signal during MPC RD FIFO	DMI Signal during MPC DQ Read Training	DMI Signal During MRR
Disable	Disable	Disable	Note 1	Note 1, 3	Note 2	Note 1	Note 2	Note 2	Note 2
Disable	Enable	Disable	Note 4	Note 3	Note 2	Note 9	Note 10	Note 11	Note 2
Disable	Disable	Enable	Note 1	Note 3	Note 5	Note 9	Note 10	Note 11	Note 12
Disable	Enable	Enable	Note 4	Note 3	Note 5	Note 9	Note 10	Note 11	Note 12
Enable	Disable	Disable	Note 6	Note 7	Note 2	Note 9	Note 10	Note 11	Note 2
Enable	Enable	Disable	Note 4	Note 8	Note 2	Note 9	Note 10	Note 11	Note 2
Enable	Disable	Enable	Note 6	Note 7	Note 5	Note 9	Note 10	Note 11	Note 12
Enable	Enable	Enable	Note 4	Note 8	Note 5	Note 9	Note 10	Note 11	Note 12

**Notes:**

1. DMI input signal is don't care. DMI input receivers are turned OFF.
2. DMI output drivers are turned OFF.
3. Masked Write Command is not allowed and is considered an illegal command as DM function is disabled.
4. DMI signal is treated as DBI signal and it indicates whether DRAM needs to invert the Write data received on DQs within a byte. The LPDDR4X device inverts Write data received on the DQ inputs in case DMI was sampled HIGH, or leaves the Write data non-inverted in case DMI was sampled LOW.
5. The LPDDR4X DRAM inverts Read data on its DQ outputs associated within a byte and drives DMI signal HIGH when the number of '1' data bits within a given byte lane is greater than four; otherwise the DRAM does not invert the read data and drives DMI signal LOW.
6. The LPDDR4X DRAM does not perform any mask operation when it receives Write command. During the Write burst associated with Write command, DMI signal must be driven LOW.
7. The LPDDR4X DRAM requires an explicit Masked Write command for all masked write operations. DMI signal is treated as DM signal and it indicates which bit time within the burst is to be masked. When DMI signal is HIGH, DRAM masks that bit time across all DQs associated within a byte. All DQ input signals within a byte are don't care (either HIGH or LOW) when DMI signal is HIGH. When DMI signal is LOW, the LPDDR4X DRAM does not perform mask operation and data received on DQ input is written to the array.
8. The LPDDR4X DRAM requires an explicit Masked Write command for all masked write operations. The LPDDR4X device masks the Write data received on the DQ inputs if the total count of '1' data bits on DQ[2:7] or DQ[10:15] (for Lower Byte or Upper Byte respectively) is equal to or greater than five and DMI signal is LOW. Otherwise the LPDDR4X DRAM does not perform mask operation and treats it as a legal DBI pattern; DMI signal is treated as DBI signal and data received on DQ input is written to the array.
9. DMI signal is treated as a training pattern. The LPDDR4X DRAM does not perform any mask operation and does not invert Write data received on the DQ inputs.
10. DMI signal is treated as a training pattern. The LPDDR4X DRAM returns DMI pattern written in WR FIFO.
11. DMI signal is treated as a training pattern. For more details, see 7.4.31, RD DQ Calibration.
12. DBI not apply during normal MRR. If read DBI is enable with MRS, DBI pin status should be low.

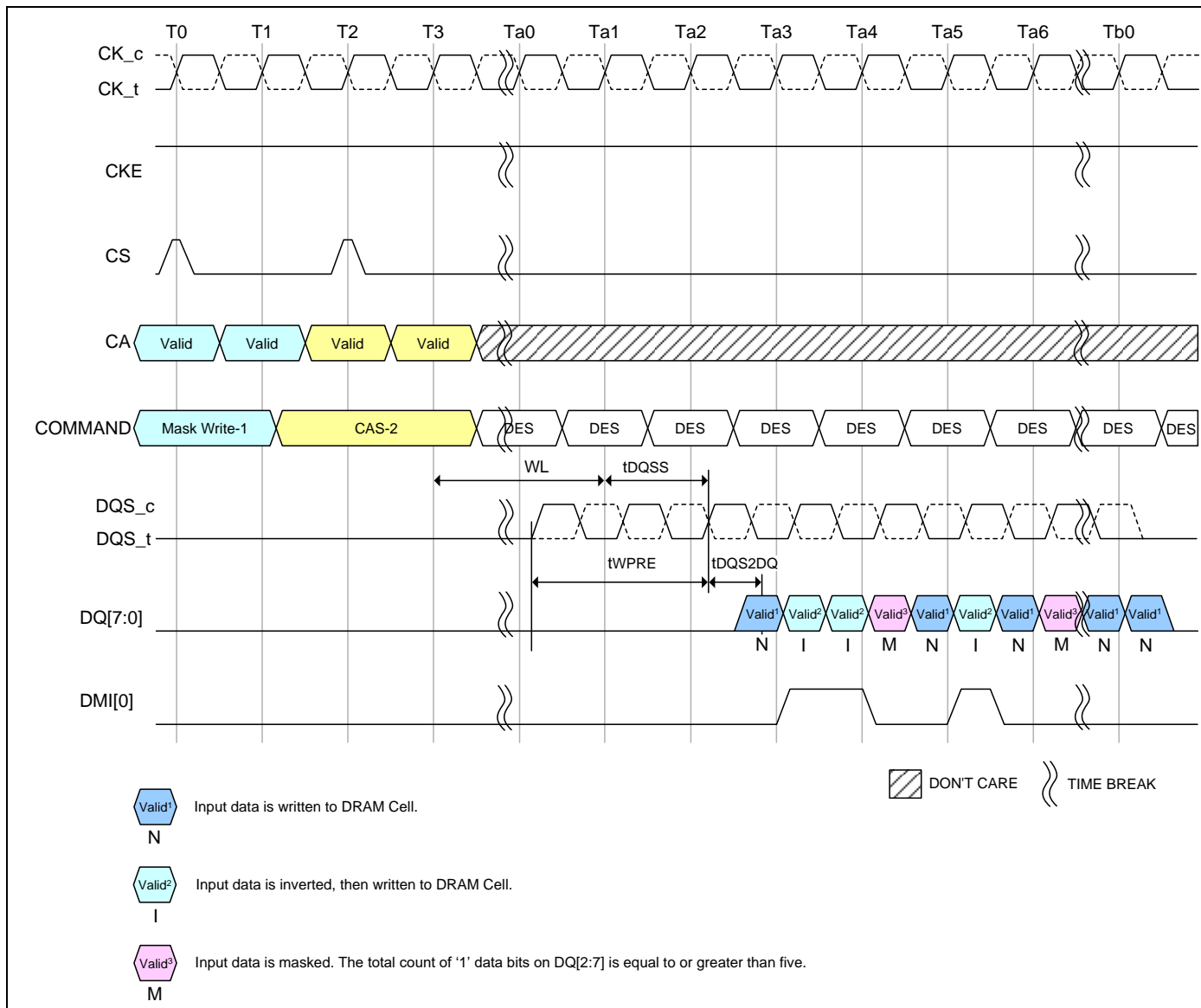

Note: 1. Data Mask (DM) is Enable: MR13 OP [5] = 0, Data Bus Inversion (DBI) Write is Enable: MR3 OP[7] = 1.

Figure 54 - Masked Write Command w/ Write DBI Enabled; DM Enabled

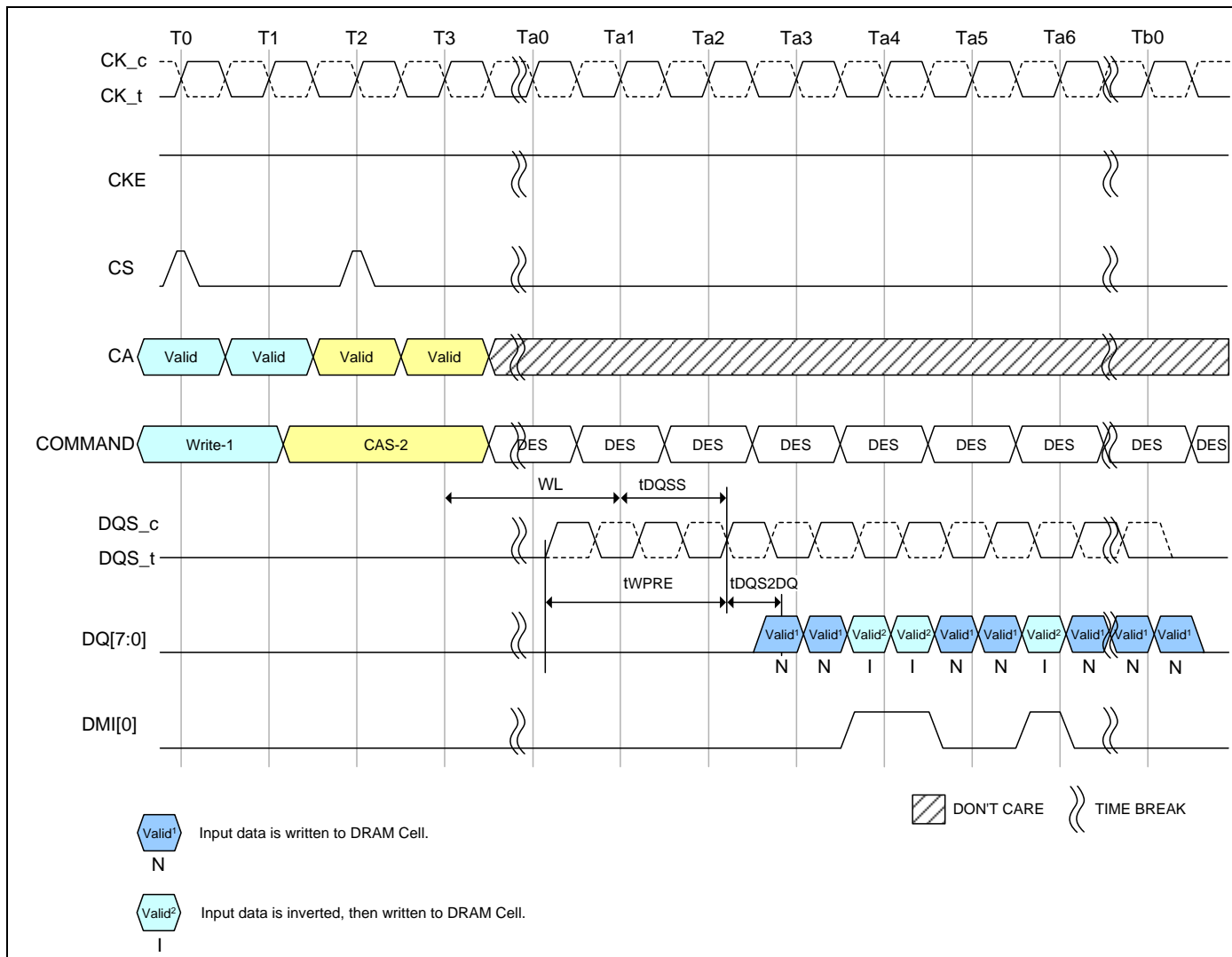

**Note:** 1. Data Mask (DM) is Disable: MR13 OP [5] = 1, Data Bus Inversion (DBI) Write is Enable: MR3 OP[7] = 1.

**Figure 55 - Write Command w/ Write DBI Enabled; DM Disabled**



#### 7.4.17 Precharge Operation

The PRECHARGE command is used to precharge or close a bank that has been activated. The PRECHARGE command is initiated with CS, and CA[5:0] in the proper state as defined by the Command Truth Table. The PRECHARGE command can be used to precharge each bank independently or all banks simultaneously. The AB flag and the bank address bit are used to determine which bank(s) to precharge. The precharged bank(s) will be available for subsequent row access tRPab after an all bank PRECHARGE command is issued, or tRPpb after a single-bank PRECHARGE command is issued.

To ensure that LPDDR4X devices can meet the instantaneous current demands, the row-precharge time for an all bank PRECHARGE (tRPab) is longer than the per bank precharge time (tRPpb).

**Table 34 - Precharge Bank Selection**

AB (CA[5], R1)	BA2 (CA[2], R2)	BA1 (CA[1], R2)	BA0 (CA[0], R2)	Precharged Bank(s)
0	0	0	0	Bank 0 only
0	0	0	1	Bank 1 only
0	0	1	0	Bank 2 only
0	0	1	1	Bank 3 only
0	1	0	0	Bank 4 only
0	1	0	1	Bank 5 only
0	1	1	0	Bank 6 only
0	1	1	1	Bank 7 only
1	Valid	Valid	Valid	All Banks



7.4.17.1 Burst Read Operation Followed by a Precharge

The PRECHARGE command can be issued as early as BL/2 clock cycles after a READ command, but PRECHARGE cannot be issued until after tRAS is satisfied. A new bank ACTIVATE command can be issued to the same bank after the row PRECHARGE time (tRP) has elapsed. The minimum READ-to-PRECHARGE time must also satisfy a minimum analog time from the 2nd rising clock edge of the CAS-2 command. tRTP begins BL/2 - 8 clock cycles after the READ command. For LPDDR4X READ-to-PRECHARGE timings see Table 35.

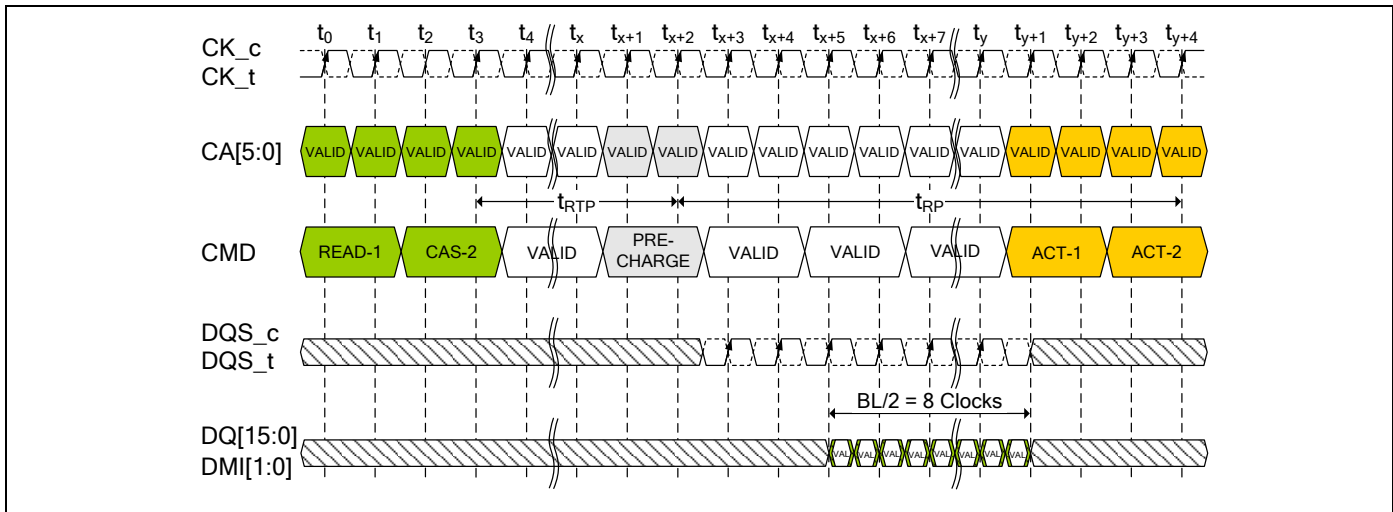

Figure 56 - Burst READ followed by PRECHARGE  
(Shown with BL16, 2tCK pre-ample)

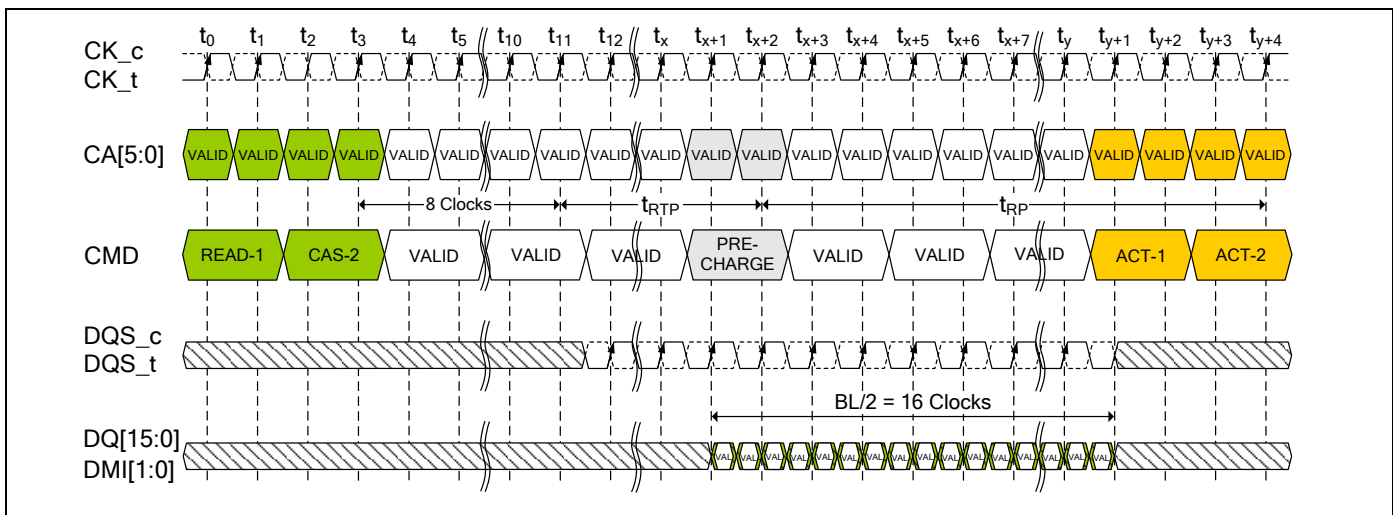

Figure 57 - Burst READ followed by PRECHARGE  
(Shown with BL32, 2tCK pre-ample)



**7.4.17.2 Burst Write Operation Followed by a Precharge**

A Write Recovery time ( $t_{WR}$ ) must be provided before a PRECHARGE command may be issued. This delay is referenced from the next rising edge of  $CK\_t$  after the last latching DQS clock of the burst.

LPDDR4X-SDRAM devices write data to the memory array in prefetch multiples (prefetch=16). An internal WRITE operation can only begin after a prefetch group has been clocked, so  $t_{WR}$  starts at the prefetch boundaries. The minimum WRITE-to-PRECHARGE time for commands to the same bank is  $WL + BL/2 + 1 + RU(t_{WR}/t_{CK})$  clock cycles.

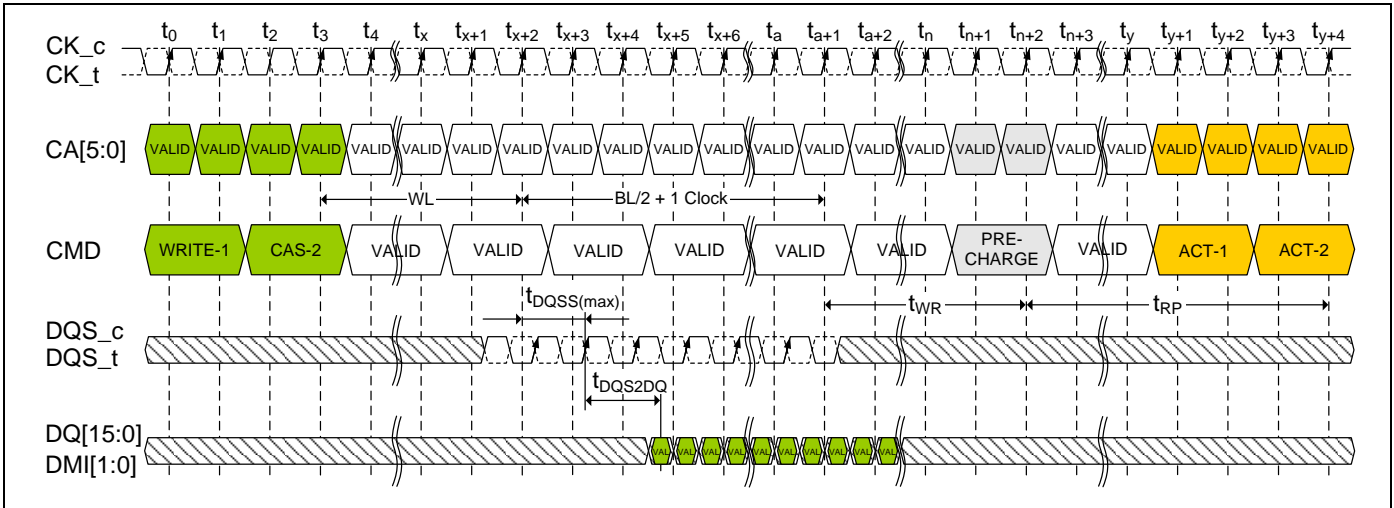

**Figure 58 - Burst WRITE Followed by PRECHARGE**  
(Shown with BL16, 2tCK pre-amble)

**7.4.17.3 Auto-Precharge Operation**

Before a new row can be opened in an active bank, the active bank must be precharged using either the PRECHARGE command or the Auto-Precharge function. When a READ, a WRITE or Masked Write command is issued to the device, the AP bit (CA5) can be set to enable the active bank to automatically begin precharge at the earliest possible moment during the burst READ, WRITE or Masked Write cycle.

If AP is LOW when the READ or WRITE command is issued, then the normal READ, WRITE or Masked Write burst operation is executed and the bank remains active at the completion of the burst.

If AP is HIGH when the READ, WRITE or Masked Write command is issued, the Auto-Precharge function is engaged. This feature enables the PRECHARGE operation to be partially or completely hidden during burst READ cycles (dependent upon READ or WRITE latency), thus improving system performance for random data access.





**7.4.17.4 Burst Read with Auto-Precharge**

If AP is HIGH when a READ command is issued, the READ with Auto-Precharge function is engaged. An internal precharge procedure starts a following delay time after the READ command. And this delay time depends on BL setting.

BL = 16: nRTP

BL = 32: 8nCK + nRTP

For LPDDR4X Auto-Precharge calculations, see Table 35. Following an Auto-Precharge operation, an ACTIVATE command can be issued to the same bank if the following two conditions are both satisfied:

- a. The RAS precharge time (t<sub>RP</sub>) has been satisfied from the clock at which the Auto-Precharge began, or
- b. The RAS cycle time (t<sub>RC</sub>) from the previous bank activation has been satisfied.

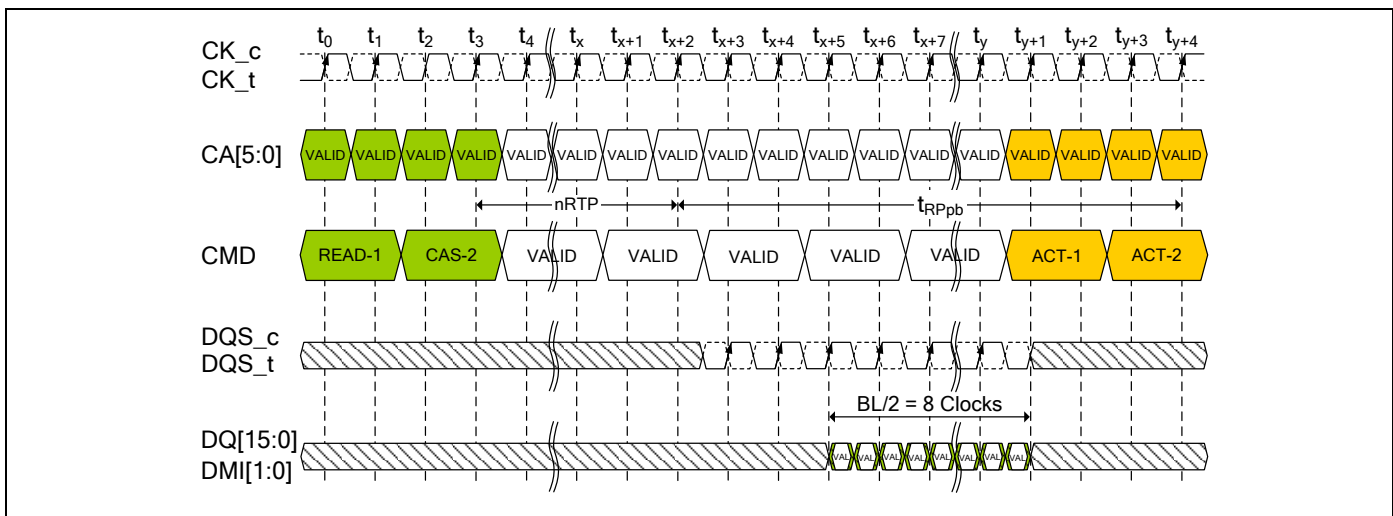

**Figure 59 - Burst READ with Auto-Precharge  
(Shown with BL16, 2tCK pre-amble)**

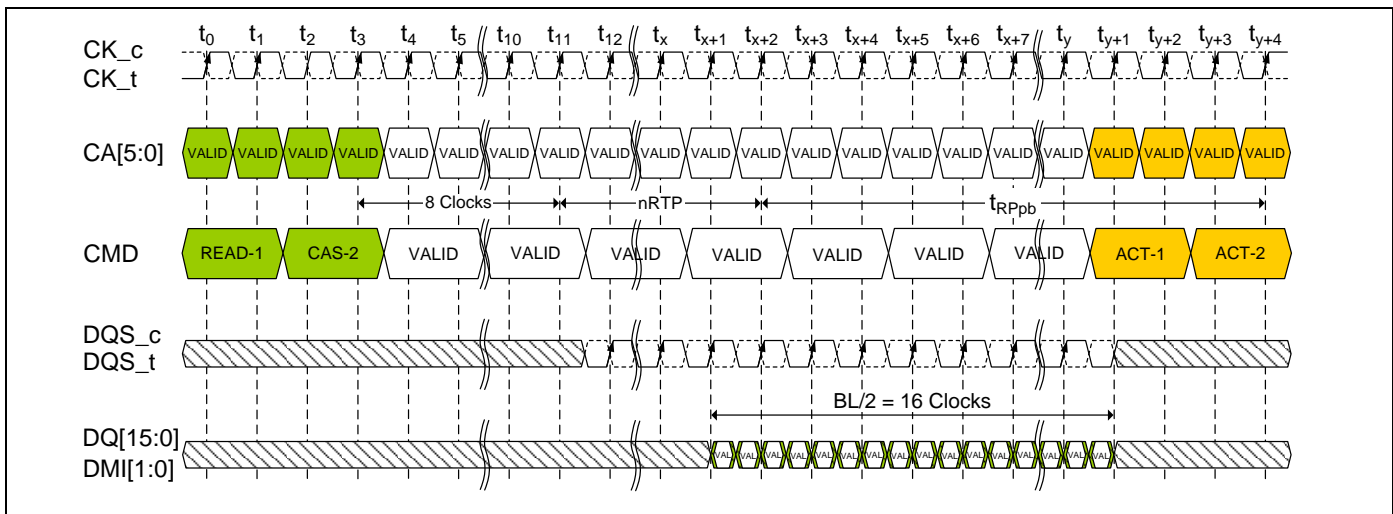

**Figure 60 - Burst READ with Auto-Precharge  
(Shown with BL32, 2tCK pre-amble)**





**7.4.17.5 Burst Write with Auto-Precharge**

If AP is HIGH when a WRITE command is issued, the WRITE with Auto-Precharge function is engaged. The device starts an Auto-Precharge on the rising edge  $t_{WR}$  cycles after the completion of the Burst WRITE.

Following a WRITE with Auto-Precharge, an ACTIVATE command can be issued to the same bank if the following conditions are met:

- a. The RAS precharge time ( $t_{RP}$ ) has been satisfied from the clock at which the Auto-Precharge began, and
- b. The RAS cycle time ( $t_{RC}$ ) from the previous bank activation has been satisfied.

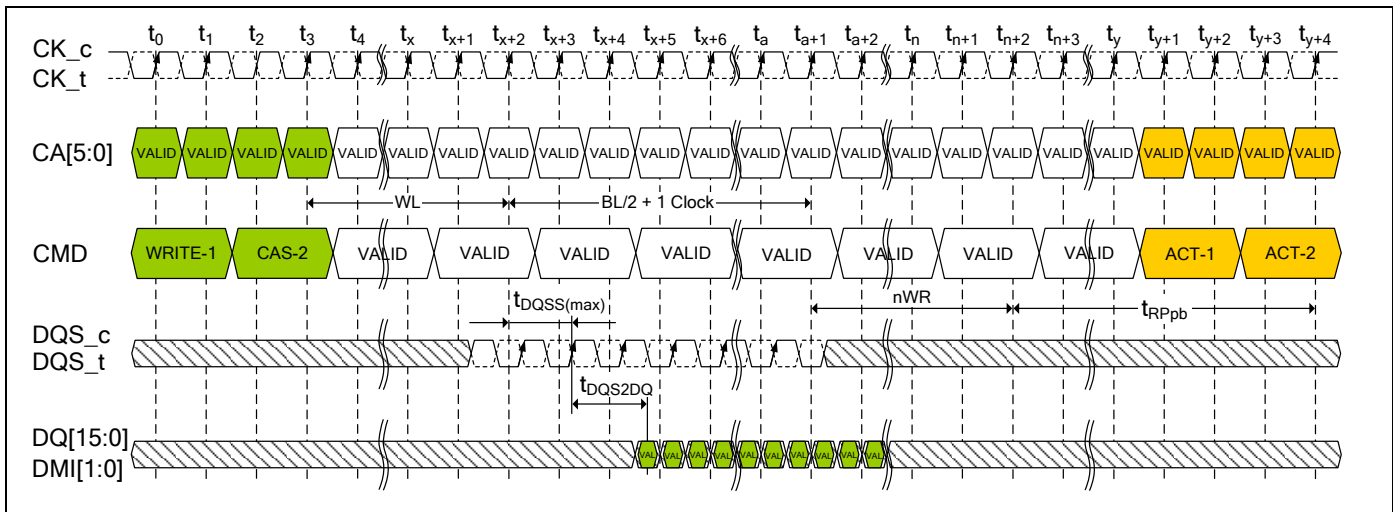

**Figure 61 - Burst WRITE with Auto-Precharge (Shown with BL16, 2tCK pre-ample)**



**7.4.18 Auto-Precharge Operation**

Before a new row can be opened in an active bank, the active bank must be precharged using either the PRECHARGE command or the Auto-Precharge function. When a READ, a WRITE or Masked Write command is issued to the device, the AP bit (CA5) can be set to enable the active bank to automatically begin precharge at the earliest possible moment during the burst READ, WRITE or Masked Write cycle.

If AP is LOW when the READ or WRITE command is issued, then the normal READ, WRITE or Masked Write burst operation is executed and the bank remains active at the completion of the burst.

If AP is HIGH when the READ, WRITE or Masked Write command is issued, the Auto-Precharge function is engaged. This feature enables the PRECHARGE operation to be partially or completely hidden during burst READ cycles (dependent upon READ or WRITE latency), thus improving system performance for random data access.

Read with Auto-Precharge or Write/Mask Write with Auto-Precharge commands may be issued after tRCD has been satisfied. The LPDDR4X SDRAM RAS Lockout feature will schedule the internal precharge to assure that tRAS is satisfied.

tRC needs to be satisfied prior to issuing subsequent Activate commands to the same bank. The figure below shows example of RAS lock function.

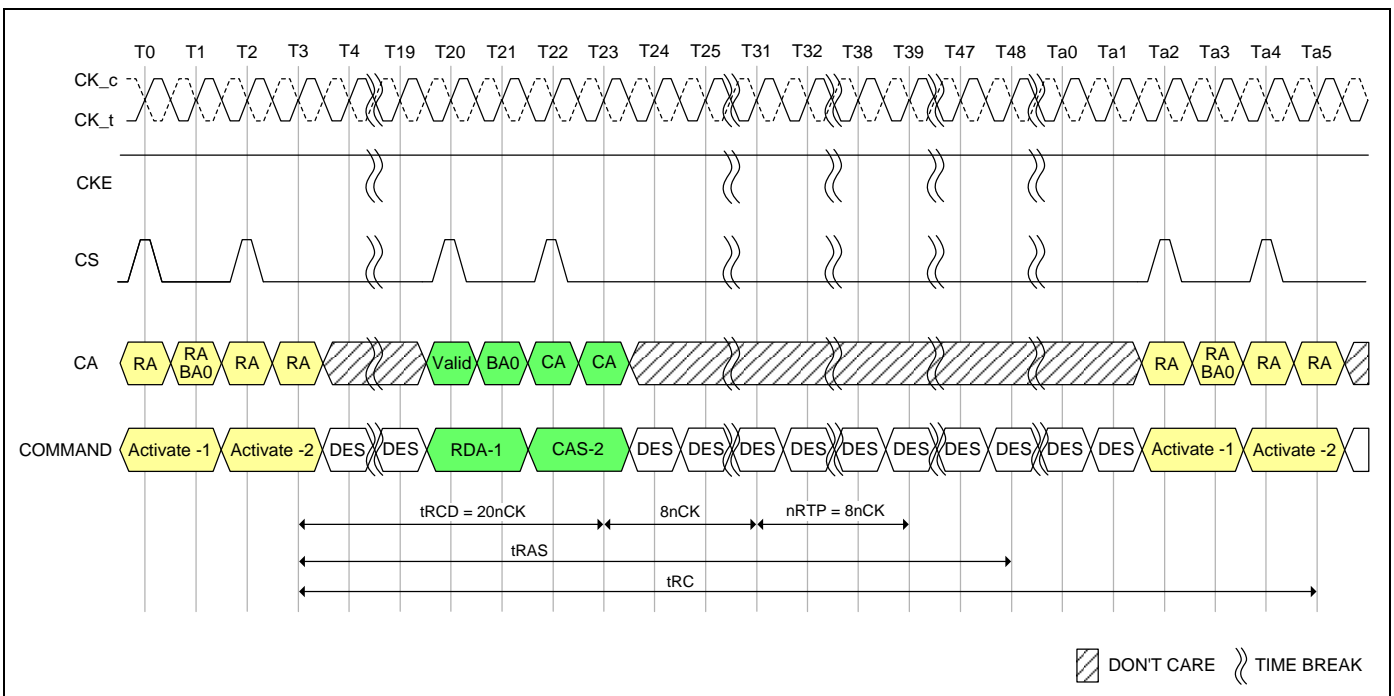

**Notes:**

1. tCK(AVG) = 0.938nS, Data Rate = 2133Mbps, tRCD(Min) = Max(18nS, 4nCK), tRAS(Min) = Max(42nS, 3nCK), nRTP = 8nCK, BL = 32.
2. tRCD = 20nCK comes from Roundup(18nS/0.938nS).
3. DES commands are shown for ease of illustration; other commands may be valid at these times.

**Figure 62 - Command Input Timing with RAS lock**



**7.4.18.1 Delay time from Write to Read with Auto-Precharge**

In the case of write command followed by read with Auto-Precharge, controller must satisfy  $tWR$  for the write command before initiating the DRAM internal Auto-Precharge. It means that  $(tWTR + nRTP)$  should be equal or longer than  $(tWR)$  when BL setting is 16, as well as  $(tWTR + nRTP + 8nCK)$  should be equal or longer than  $(tWR)$  when BL setting is 32. Refer to the following figure for details.

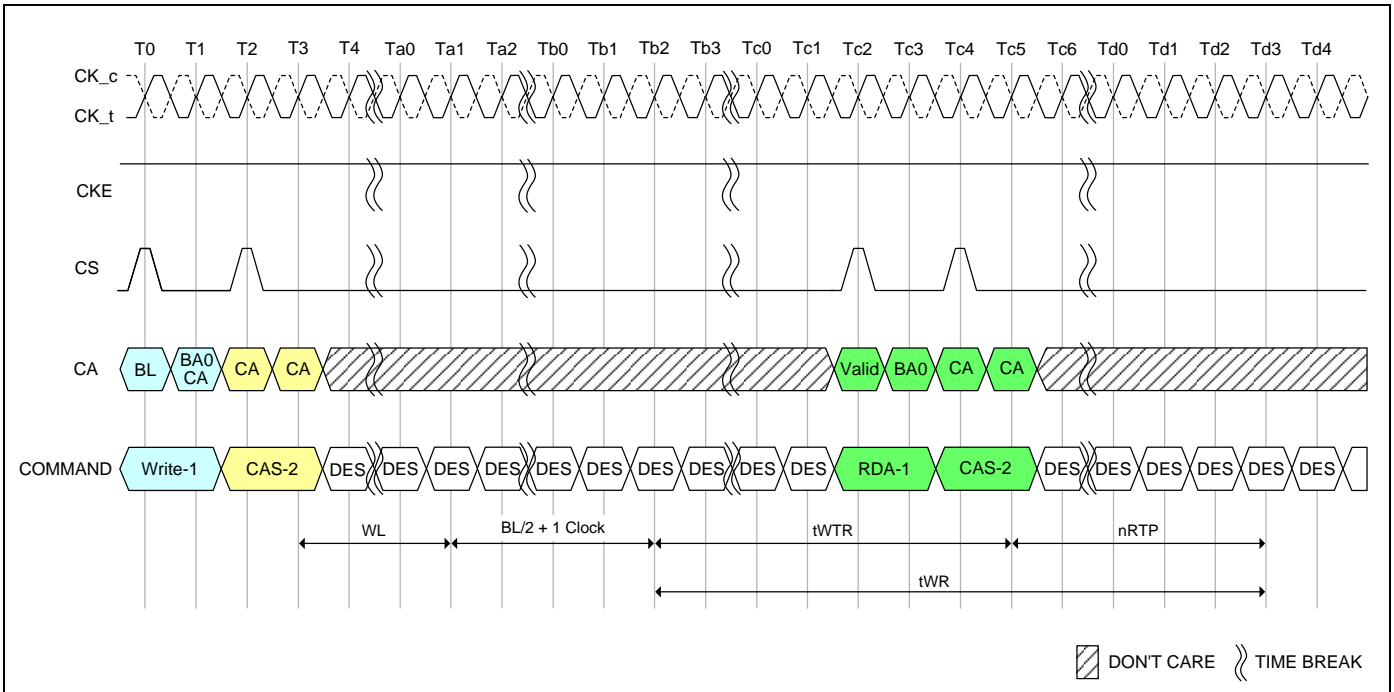

**Notes:**

1. Burst Length at Read = 16.
2. DES commands are shown for ease of illustration; other commands may be valid at these times.

**Figure 63 - Delay time from Write to Read with Auto-Precharge**



Table 35 - Timing between Commands (PRECHARGE and Auto-Precharge): DQ ODT is Disable

From Command	To Command	Minimum Delay between "From Command" and "To Command"	Unit	Notes
READ BL=16	PRECHARGE (to same bank as Read)	tRTP	tCK	1,6
	PRECHARGE All	tRTP	tCK	1,6
READ BL=32	PRECHARGE (to same bank as Read)	8tCK + tRTP	tCK	1,6
	PRECHARGE All	8tCK + tRTP	tCK	1,6
READ w/AP BL=16	PRECHARGE (to same bank as READ w/AP)	nRTP	tCK	1,10
	PRECHARGE All	nRTP	tCK	1,10
	Activate (to same bank as READ w/AP)	nRTP + tRPpb	tCK	1,8,10
	WRITE or WRITE w/AP (same bank)	Illegal	-	
	MASK-WR or MASK-WR w/AP (same bank)	Illegal	-	
	WRITE or WRITE w/AP (different bank)	RL+RU(tDQSCK(max)/tCK)+BL/2+RD(tRPST)-WL+tWPRE	tCK	3,4,5
	MASK-WR or MASK-WR w/AP (different bank)	RL+RU(tDQSCK(max)/tCK)+BL/2+RD(tRPST)-WL+tWPRE	tCK	3,4,5
	READ or READ w/AP (same bank)	Illegal	-	
	READ or READ w/AP (different bank)	BL/2	tCK	3
READ w/AP BL=32	PRECHARGE (to same bank as READ w/AP)	8tCK + nRTP	tCK	1,10
	PRECHARGE All	8tCK + nRTP	tCK	1,10
	Activate (to same bank as READ w/AP)	8tCK + nRTP + tRPpb	tCK	1,8,10
	WRITE or WRITE w/AP (same bank)	Illegal	-	
	MASK-WR or MASK-WR w/AP (same bank)	Illegal	-	
	WRITE or WRITE w/AP (different bank)	RL+RU(tDQSCK(max)/tCK)+BL/2+RD(tRPST)-WL+tWPRE	tCK	3,4,5
	MASK-WR or MASK-WR w/AP (different bank)	RL+RU(tDQSCK(max)/tCK)+BL/2+RD(tRPST)-WL+tWPRE	tCK	3,4,5
	READ or READ w/AP (same bank)	Illegal	-	
	READ or READ w/AP (different bank)	BL/2	tCK	3



Table 35 - Timing between Commands (PRECHARGE and Auto-Precharge): DQ ODT is Disable (cont'd)

From Command	To Command	Minimum Delay between "From Command" and "To Command"	Unit	Notes
WRITE BL=16 & 32	PRECHARGE (to same bank as WRITE)	$WL + BL/2 + tWR + 1$	tCK	1,7
	PRECHARGE All	$WL + BL/2 + tWR + 1$	tCK	1,7
MASK-WR BL=16	PRECHARGE (to same bank as MASK-WR)	$WL + BL/2 + tWR + 1$	tCK	1,7
	PRECHARGE All	$WL + BL/2 + tWR + 1$	tCK	1,7
WRITE w/AP BL=16 & 32	PRECHARGE (to same bank as WRITE w/AP)	$WL + BL/2 + nWR + 1$	tCK	1,11
	PRECHARGE All	$WL + BL/2 + nWR + 1$	tCK	1,11
	ACTIVATE (to same bank as WRITE w/AP)	$WL + BL/2 + nWR + 1 + tRPpb$	tCK	1,8,11
	WRITE or WRITE w/AP (same bank)	Illegal	-	
	READ or READ w/AP (same bank)	Illegal	-	
	WRITE or WRITE w/AP (different bank)	BL/2	tCK	3
	MASK-WR or MASK-WR w/AP (different bank)	BL/2	tCK	3
	READ or READ w/AP (different bank)	$WL + BL/2 + tWTR + 1$	tCK	3,9
MASK-WR w/AP BL=16	PRECHARGE (to same bank as MASK-WR w/AP)	$WL + BL/2 + nWR + 1$	tCK	1,11
	PRECHARGE All	$WL + BL/2 + nWR + 1$	tCK	1,11
	ACTIVATE (to same bank as MASK-WR w/AP)	$WL + BL/2 + nWR + 1 + tRPpb$	tCK	1,8,11
	WRITE or WRITE w/AP (same bank)	Illegal	-	3
	MASK-WR or MASK-WR w/AP (same bank)	Illegal	-	3
	WRITE or WRITE w/AP (different bank)	BL/2	tCK	3
	MASK-WR or MASK-WR w/AP (different bank)	BL/2	tCK	3
	READ or READ w/AP (same bank)	Illegal	-	3
	READ or READ w/AP (different bank)	$WL + BL/2 + tWTR + 1$	tCK	3,9



Table 35 - Timing between Commands (PRECHARGE and Auto-Precharge): DQ ODT is Disable (cont'd)

From Command	To Command	Minimum Delay between "From Command" and "To Command"	Unit	Notes
PRECHARGE	PRECHARGE (to same bank as PRECHARGE)	4	tCK	1
	PRECHARGE All	4	tCK	1
PRECHARGE All	PRECHARGE	4	tCK	1
	PRECHARGE All	4	tCK	1

**Notes:**

- For a given bank, the precharge period should be counted from the latest precharge command, whether per bank or all bank, issued to that bank. The precharge period is satisfied tRP after that latest precharge command.
- Any command issued during the minimum delay time as specified in the table above is illegal.
- After READ w/AP, seamless read operations to different banks are supported. After WRITE w/AP or MASK-WR w/AP, seamless write operations to different banks are supported. READ, WRITE, and MASK-WR operations may not be truncated or interrupted.
- tRPST values depend on MR1-OP[7] respectively.
- tWPRE values depend on MR1-OP[2] respectively.
- Minimum Delay between "From Command" and "To Command" in clock cycle is calculated by dividing tRTP(in nS) by tCK(in nS) and rounding up to the next integer: Minimum Delay[cycles] = Roundup(tRTP[nS] / tCK[nS]).
- Minimum Delay between "From Command" and "To Command" in clock cycle is calculated by dividing tWR(in nS) by tCK(in nS) and rounding up to the next integer: Minimum Delay[cycles] = Roundup(tWR[nS] / tCK[nS]).
- Minimum Delay between "From Command" and "To Command" in clock cycle is calculated by dividing tRPpb(in nS) by tCK(in nS) and rounding up to the next integer: Minimum Delay[cycles] = Roundup(tRPpb[nS] / tCK[nS]).
- Minimum Delay between "From Command" and "To Command" in clock cycle is calculated by dividing tWTR(in nS) by tCK(in nS) and rounding up to the next integer: Minimum Delay[cycles] = Roundup(tWTR[nS] / tCK[nS]).
- For Read w/AP the value is nRTP which is defined in Mode Register 2.
- For Write w/AP the value is nWR which is defined in Mode Register 1.

Table 36 - Timing between Commands (read w/ AP and write command): DQ ODT is Enabled

From Command	To Command	Minimum Delay between "From Command" and "To Command"	Unit	Notes
READ w/AP BL=16	WRITE or WRITE w/AP (different bank)	$RL + RU(tDQSK(max)/tCK) + BL/2 + RD(tRPST) - ODTLon - RD(tODTon,min/tCK) + 1$	tCK	2,3
	MASK-WR or MASK-WR w/AP (different bank)	$RL + RU(tDQSK(max)/tCK) + BL/2 + RD(tRPST) - ODTLon - RD(tODTon,min/tCK) + 1$	tCK	2,3
READ w/AP BL=32	WRITE or WRITE w/AP (different bank)	$RL + RU(tDQSK(max)/tCK) + BL/2 + RD(tRPST) - ODTLon - RD(tODTon,min/tCK) + 1$	tCK	2,3
	MASK-WR or MASK-WR w/AP (different bank)	$RL + RU(tDQSK(max)/tCK) + BL/2 + RD(tRPST) - ODTLon - RD(tODTon,min/tCK) + 1$	tCK	2,3

**Notes:**

- The rest of the timing about precharge and Auto-Precharge is same as DQ ODT is Disable case.
- After READ w/AP, seamless read operations to different banks are supported. READ, WRITE, and MASK-WR operations may not be truncated or interrupted.
- tRPST values depend on MR1-OP[7] respectively.



**7.4.19 Refresh command**

The REFRESH command is initiated with CS HIGH, CA0 LOW, CA1 LOW, CA2 LOW, CA3 HIGH and CA4 LOW at the first rising edge of the clock. Per bank REFRESH is initiated with CA5 LOW at the first rising edge of the clock. All bank REFRESH is initiated with CA5 HIGH at the first rising edge of the clock.

A per bank REFRESH command (REFpb) is performed to the bank address as transferred on CA0, CA1 and CA2 at the second rising edge of the clock. Bank address BA0 is transferred on CA0, bank address BA1 is transferred on CA1 and bank address BA2 is transferred on CA2. A per bank REFRESH command (REFpb) to the eight banks can be issued in any order. e.g. REFpb commands are issued in the following order: 1-3-0-2-4-7-5-6. After the eight banks have been refreshed using the per bank REFRESH command the controller can send another set of per bank REFRESH commands in the same order or a different order. e.g. REFpb commands are issued in the following order that is different from the previous order: 7-1-3-5-0-4-2-6. One of the possible order can also be a sequential round robin: 0-1-2-3-4-5-6-7. It is illegal to send a per-bank REFRESH command to the same bank unless all eight banks have been refreshed using the per bank REFRESH command. The count of eight REFpb commands starts with the first REFpb command after a synchronization event.

The bank count is synchronized between the controller and the SDRAM by resetting the bank count to zero. Synchronization can occur upon asserting RESET\_n or at every exit from Self Refresh. REFab command also synchronizes the counter between the controller and SDRAM to zero. The SDRAM device can be placed in Self Refresh or a REFab command can be issued at any time without cycling through all eight banks using per bank REFRESH command. After the bank count is synchronized to zero the controller can issue per bank REFRESH commands in any order as described in the previous paragraph.

A REFab command issued when the bank counter is not zero will reset the bank counter to zero and the DRAM will perform refreshes to all banks as indicated by the row counter. If another refresh command (REFpb or REFpb) is issued after the REFab command then it uses an incremented value of the row counter. The table below shows examples of both bank and refresh counter increment behavior.

**Table 37 - Bank and Refresh counter increment behavior**

#	Command	BA2	BA1	BA0	Refresh Bank #	Bank Counter #	Ref Counter # (Row Address #)
0	Reset, SRX or REFab					To 0	-
1	REFpb	0	0	0	0	0 to 1	n
2	REFpb	0	0	1	1	1 to 2	
3	REFpb	0	1	0	2	2 to 3	
4	REFpb	0	1	1	3	3 to 4	
5	REFpb	1	0	0	4	4 to 5	
6	REFpb	1	0	1	5	5 to 6	
7	REFpb	1	1	0	6	6 to 7	
8	REFpb	1	1	1	7	7 to 0	
9	REFpb	1	1	0	6	0 to 1	n + 1
10	REFpb	1	1	1	7	1 to 2	
11	REFpb	0	0	1	1	2 to 3	
12	REFpb	0	1	1	3	3 to 4	
13	REFpb	1	0	1	5	4 to 5	
14	REFpb	0	1	0	2	5 to 6	
15	REFpb	0	0	0	0	6 to 7	
16	REFpb	1	0	0	4	7 to 0	
17	REFpb	0	0	0	0	0 to 1	n + 2
18	REFpb	0	0	1	1	1 to 2	
19	REFpb	0	1	0	2	2 to 3	
20	<b>REFab</b>	<b>V</b>	<b>V</b>	<b>V</b>	<b>0~7</b>	<b>To 0</b>	<b>n + 2</b>
21	REFpb	1	1	0	6	0 to 1	n + 3
22	REFpb	1	1	1	7	1 to 2	

Snip





A bank must be idle before it can be refreshed. The controller must track the bank being refreshed by the per bank REFRESH command.

The REFpb command must not be issued to the device until the following conditions are met:

- tRFCab has been satisfied after the prior REFab command.
- tRFCpb has been satisfied after the prior REFpb command.
- tRP has been satisfied after the prior PRECHARGE command to the same bank.
- tpbR2pbR has been satisfied after the prior REFpb command to different bank.
- tRRD has been satisfied after the prior ACTIVATE command (if applicable, for example after activating a row in a different bank than the one affected by the REFpb command).

The target bank is inaccessible during per bank REFRESH cycle time (tRFCpb) or Per-bank Refresh to Per-bank Refresh different bank Time (tpbR2pbR), however, other banks within the device are accessible and can be addressed during the cycle. During the REFpb operation, any of the banks other than the one being refreshed can be maintained in an active state or accessed by a READ or a WRITE command. When the per-bank REFRESH cycle has completed, the affected bank will be in the idle state.

After issuing REFpb, these conditions must be met:

- tRFCpb must be satisfied before issuing a REFab command.
- tRFCpb must be satisfied before issuing an ACTIVATE command to the same bank.
- tRRD must be satisfied before issuing an ACTIVATE command to a different bank.
- tRFCpb must be satisfied before issuing another REFpb command to the same bank.
- tpbR2pbR must be satisfied before issuing another REFpb command to a different bank.

An all bank REFRESH command (REFab) issues a REFRESH command to all banks. All banks must be idle when REFab is issued (for instance, by issuing a PRECHARGE-all command prior to issuing an all bank REFRESH command). REFab also synchronizes the bank count between the controller and the SDRAM to zero. The REFab command must not be issued to the device until the following conditions have been met:

- tRFCab has been satisfied following the prior REFab command.
- tRFCpb has been satisfied following the prior REFpb command.
- tRP has been satisfied following the prior PRECHARGE commands.

When an all bank refresh cycle has completed, all banks will be idle. After issuing REFab:

- tRFCab latency must be satisfied before issuing an ACTIVATE command.
- tRFCab latency must be satisfied before issuing a REFab or REFpb command.

**Table 38 - REFRESH Command Scheduling Separation requirements**

Symbol	Minimum Delay From	To	Notes
tRFCab	REFab	REFab	
		Activate command to any bank	
		REFpb	
tRFCpb	REFpb	REFab	
		Activate command to same bank as REFpb	
		REFpb to the same bank	
tpbR2pbR	REFpb	REFpb to a different bank	
tRRD	REFpb	Activate command to different bank than REFpb	
	Activate	REFpb	1
		Activate command to different bank than prior Activate command	

**Note:**

1. A bank must be in the idle state before it is refreshed, so following an ACTIVATE command REFab is prohibited; REFpb is supported only if it affects a bank that is in the idle state.



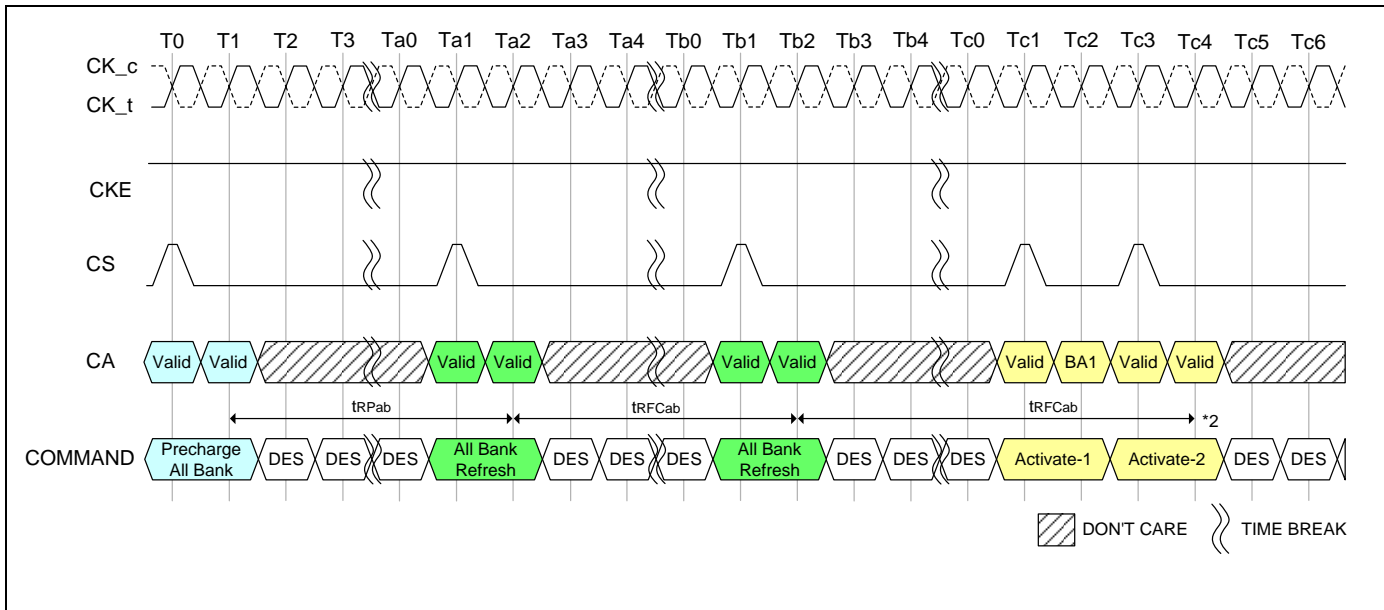

**Notes:**

1. DES commands are shown for ease of illustration; other commands may be valid at these times.
2. Activate Command is shown as an example. Other commands may be valid provided the timing specification is satisfied.

**Figure 64 - All Bank Refresh Operation**

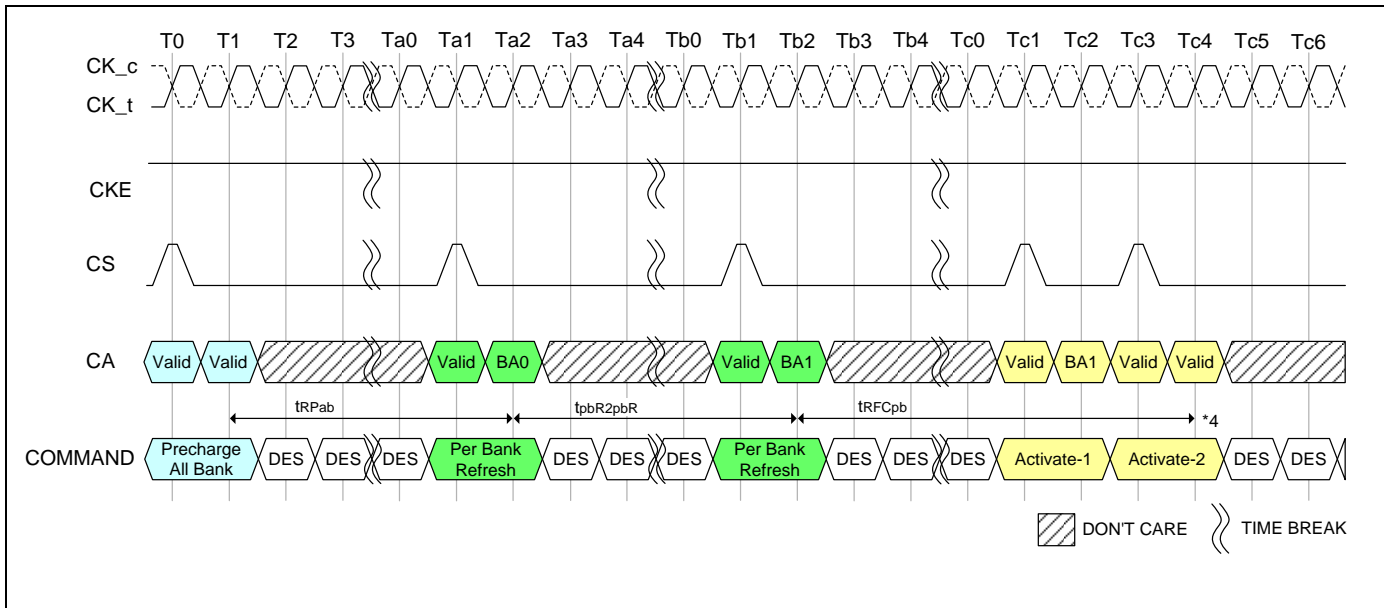

**Notes:**

1. DES commands are shown for ease of illustration; other commands may be valid at these times.
2. In the beginning of this example, the REFpb bank is pointing to bank 0.
3. Operations to banks other than the bank being refreshed are supported during the tpbR2pbR period.
4. Activate Command is shown as an example. Other commands may be valid provided the timing specification is satisfied.

**Figure 65 - Per Bank Refresh to a different bank Operation**

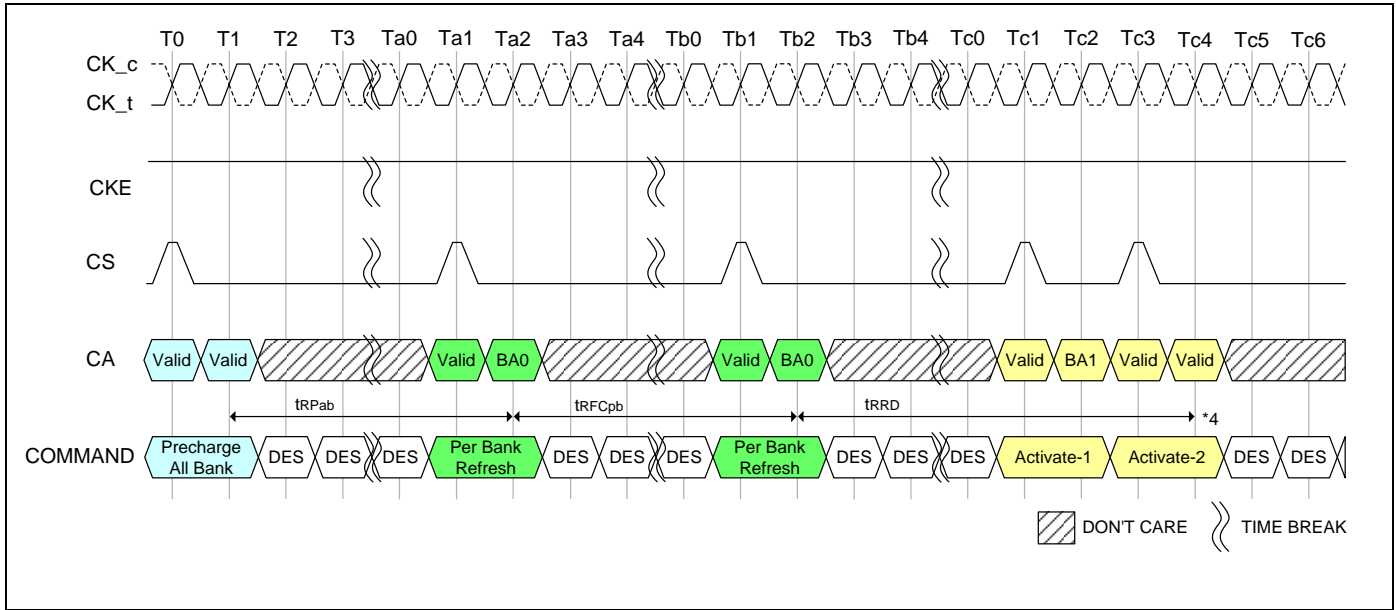

**Notes:**

1. DES commands are shown for ease of illustration; other commands may be valid at these times.
2. In the beginning of this example, the REFpb bank is pointing to bank 0.
3. Operations to banks other than the bank being refreshed are supported during the tRFCpb period.
4. Activate Command is shown as an example. Other commands may be valid provided the timing specification is satisfied.

**Figure 66 - Per Bank Refresh to the same bank Operation**

In general, a Refresh command needs to be issued to the LPDDR4X SDRAM regularly every tREFI interval. To allow for improved efficiency in scheduling and switching between tasks, some flexibility in the absolute refresh interval is provided. A maximum of 8 Refresh commands can be postponed during operation of the LPDDR4X SDRAM, meaning that at no point in time more than a total of 8 Refresh commands are allowed to be postponed and maximum number of pulled-in or postponed REF command is dependent on refresh rate. It is described in the table below. In case that 8 Refresh commands are postponed in a row, the resulting maximum interval between the surrounding Refresh commands is limited to  $9 \times tREFI$ . A maximum of 8 additional Refresh commands can be issued in advance ("pulled in"), with each one reducing the number of regular Refresh commands required later by one. Note that pulling in more than 8 Refresh commands in advance does not further reduce the number of regular Refresh commands required later, so that the resulting maximum interval between two surrounding Refresh commands is limited to  $9 \times tREFI$ .



At any given time, a maximum of 16 REF commands can be issued within  $2 \times t_{REFI}$ . Self Refresh Mode may be entered with a maximum of eight Refresh commands being postponed. After exiting Self Refresh Mode with one or more Refresh commands postponed, additional Refresh commands may be postponed to the extent that the total number of postponed Refresh commands (before and after the Self Refresh) will never exceed eight. During Self Refresh Mode, the number of postponed or pulled-in REF commands does not change.

And for per bank refresh, a maximum 8 x 8 per bank refresh commands can be postponed or pulled in for scheduling efficiency. At any given time, a maximum of  $2 \times 8 \times 8$  per bank refresh commands can be issued within  $2 \times t_{REFI}$ .

**Table 39 - Legacy Refresh Command Timing Constraints**

MR4 OP[2:0]	Refresh rate	Max. No. of pulled-in or postponed REFAb	Max. Interval between two REFAb	Max. No. of REFAb within $\max(2 \times t_{REFI} \times \text{refresh rate multiplier}, 16 \times t_{RFC})$	Per bank Refresh
000 <sub>b</sub>	Low Temp. Limit	N/A	N/A	N/A	N/A
001 <sub>b</sub>	4x tREFI	8	$9 \times 4 \times t_{REFI}$	16	1/8 of REFAb
010 <sub>b</sub>	2x tREFI	8	$9 \times 2 \times t_{REFI}$	16	1/8 of REFAb
011 <sub>b</sub>	1x tREFI	8	$9 \times t_{REFI}$	16	1/8 of REFAb
100 <sub>b</sub>	0.5x tREFI	8	$9 \times 0.5 \times t_{REFI}$	16	1/8 of REFAb
101 <sub>b</sub>	0.25x tREFI	8	$9 \times 0.25 \times t_{REFI}$	16	1/8 of REFAb
110 <sub>b</sub>	0.25x tREFI	8	$9 \times 0.25 \times t_{REFI}$	16	1/8 of REFAb
111 <sub>b</sub>	High Temp. Limit	N/A	N/A	N/A	N/A

**Table 40 - Modified REFRESH Command Timing Constraints**

MR4 OP[2:0]	Refresh rate	Max. No. of pulled-in or postponed REFAb	Max. Interval between two REFAb	Max. No. of REFAb within $\max(2 \times t_{REFI} \times \text{refresh rate multiplier}, 16 \times t_{RFC})$	Per bank Refresh
000 <sub>b</sub>	Low Temp. Limit	N/A	N/A	N/A	N/A
001 <sub>b</sub>	4x tREFI	2	$3 \times 4 \times t_{REFI}$	4	1/8 of REFAb
010 <sub>b</sub>	2x tREFI	4	$5 \times 2 \times t_{REFI}$	8	1/8 of REFAb
011 <sub>b</sub>	1x tREFI	8	$9 \times t_{REFI}$	16	1/8 of REFAb
100 <sub>b</sub>	0.5x tREFI	8	$9 \times 0.5 \times t_{REFI}$	16	1/8 of REFAb
101 <sub>b</sub>	0.25x tREFI	8	$9 \times 0.25 \times t_{REFI}$	16	1/8 of REFAb
110 <sub>b</sub>	0.25x tREFI	8	$9 \times 0.25 \times t_{REFI}$	16	1/8 of REFAb
111 <sub>b</sub>	High Temp. Limit	N/A	N/A	N/A	N/A

**Notes:**

- For any thermal transition phase where Refresh mode is transitioned to either  $2 \times t_{REFI}$  or  $4 \times t_{REFI}$ , DRAM will support the previous postponed refresh requirement provided the number of postponed refreshes is monotonically reduced to meet the new requirement. However, the pulled-in refresh commands in previous thermal phase are not applied in new thermal phase. Entering new thermal phase the controller must count the number of pulled-in refresh commands as zero, regardless of remaining pulled-in refresh commands in previous thermal phase.
- LPDDR4X devices are refreshed properly if memory controller issues refresh commands with same or shorter refresh period than reported by MR4 OP[2:0]. If shorter refresh period is applied, the corresponding requirements from Table apply. For example, when MR4 OP[2:0]=001<sub>B</sub>, controller can be in any refresh rate from  $4 \times t_{REFI}$  to  $0.25 \times t_{REFI}$ . When MR4 OP[2:0]=010<sub>B</sub>, the only prohibited refresh rate is  $4 \times t_{REFI}$ .

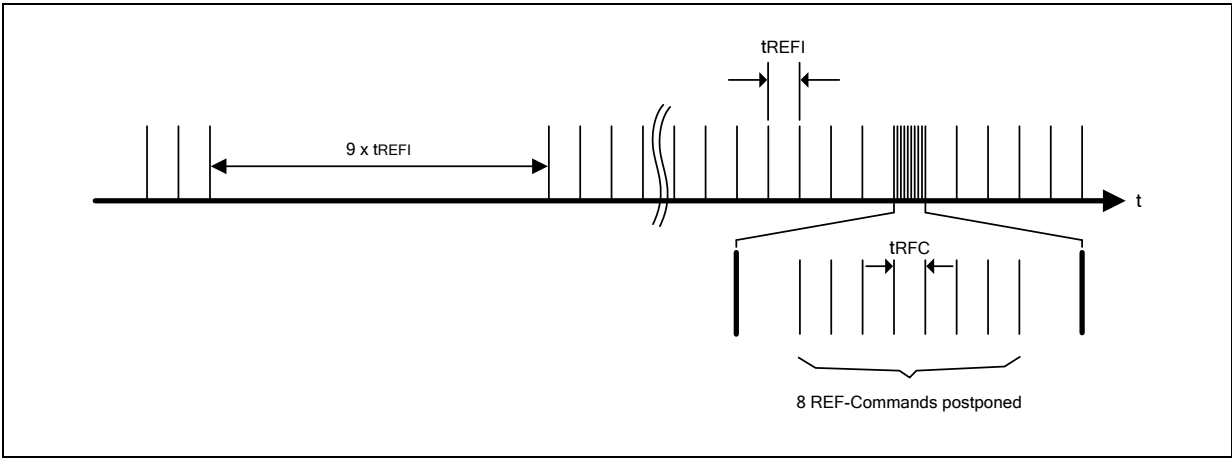

Figure 67 - Postponing Refresh Commands (Example)

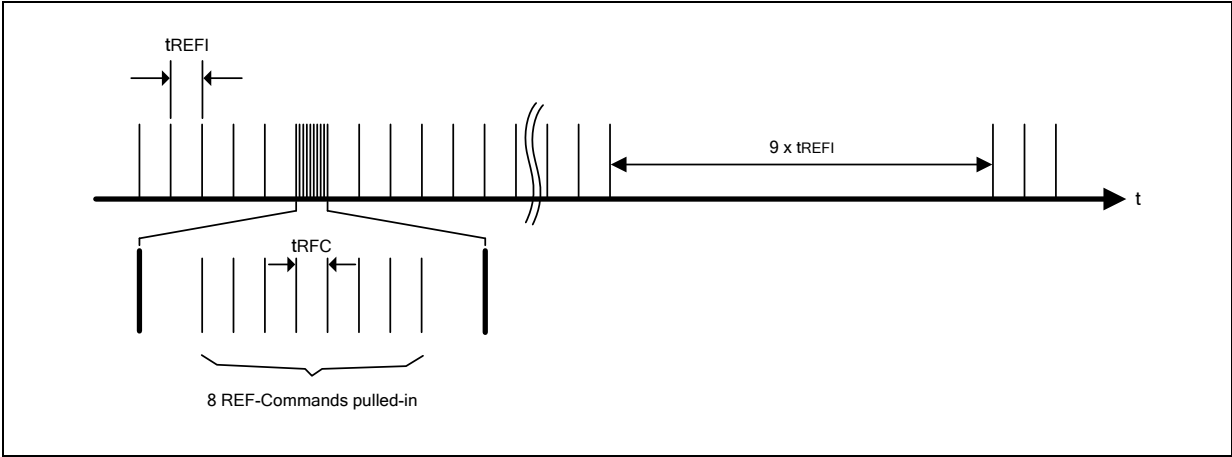
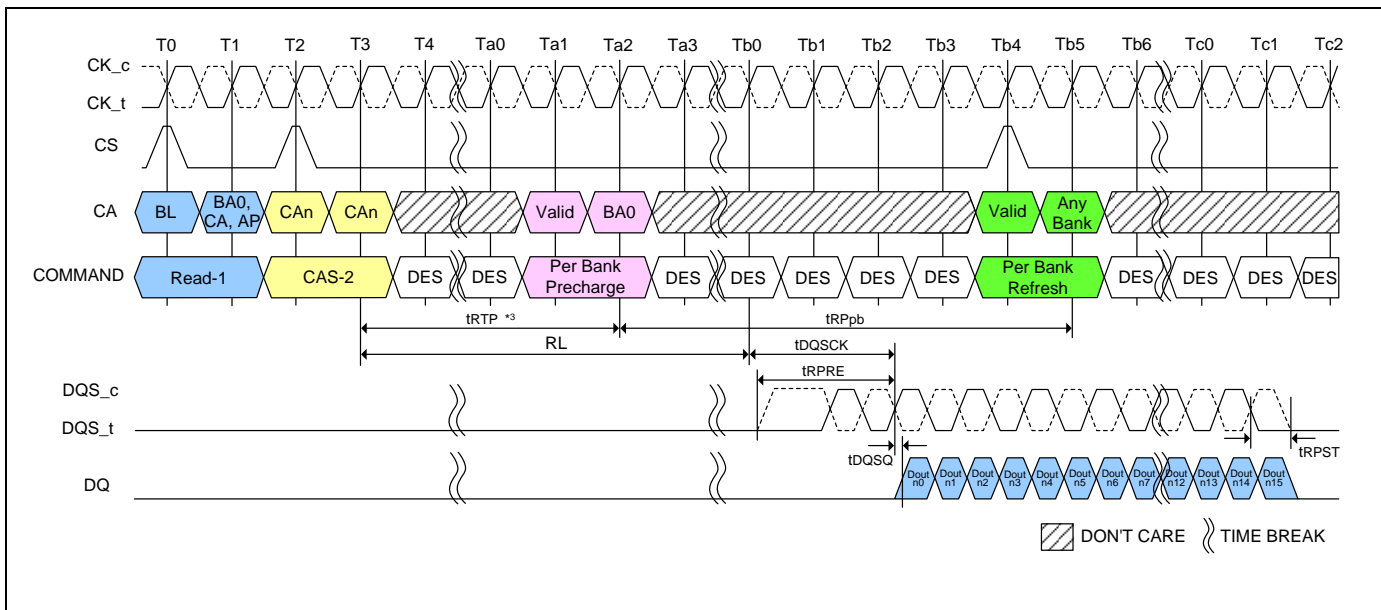

Figure 68 - Pulling-in Refresh Commands (Example)



**7.4.19.1 Burst Read operation followed by Per Bank Refresh**

The Per Bank Refresh command can be issued after  $t_{RTP} + t_{RPpb}$  from Read command.



**Notes:**

1. BL = 16, Preamble = Toggle, Postamble = 0.5nCK, DQ/DQS: VSSQ termination.
2. Dout n = data-out from column n.
3. In case of BL = 32, Delay time from Read to Per Bank Precharge is  $8nCK + t_{RTP}$ .
4. DES commands are shown for ease of illustration; other commands may be valid at these times.

**Figure 69 - Burst Read operation followed by Per Bank Refresh**

The Per Bank Refresh command can be issued after  $t_{RTP} + t_{RPpb}$  from Read command.

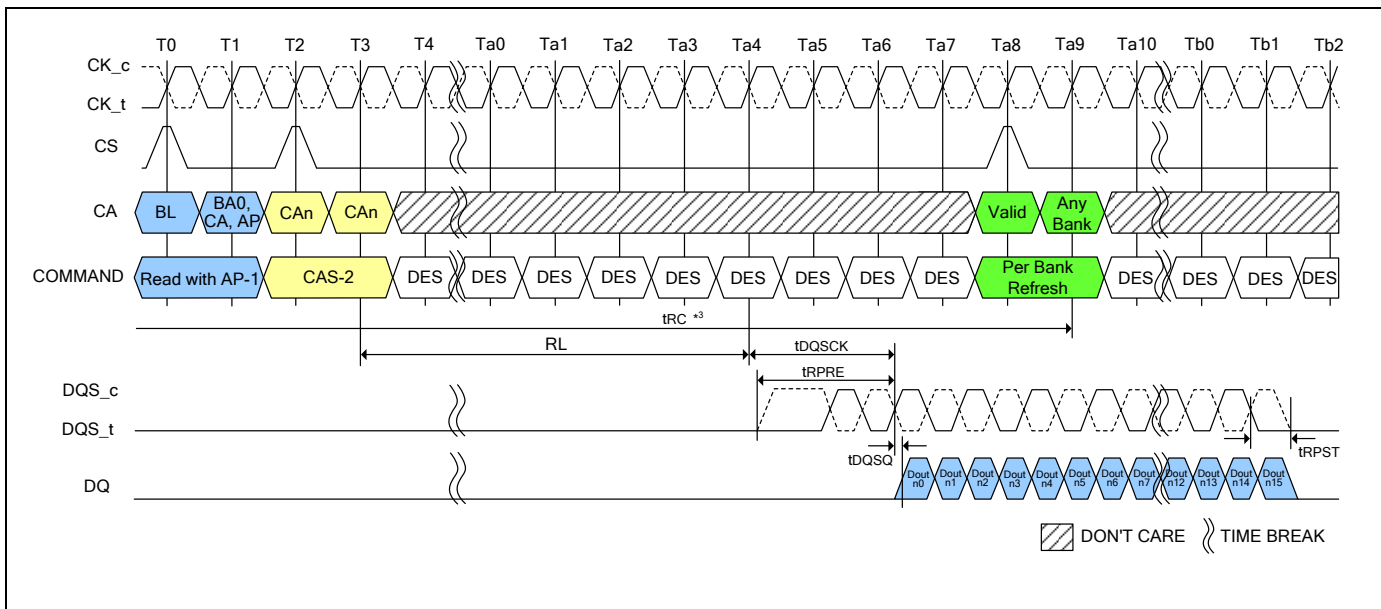

**Notes:**

1. BL = 16, Preamble = Toggle, Postamble = 0.5nCK, DQ/DQS: VSSQ termination.
2. Dout n = data-out from column n.
3.  $t_{RC}$  needs to be satisfied prior to issuing subsequent Per Bank Refresh command.
4. DES commands are shown for ease of illustration; other commands may be valid at these times.

**Figure 70 - Burst Read with Auto-Precharge operation followed by Per Bank Refresh**



## 7.4.20 Refresh Requirement

Table 41 - Refresh Requirement Parameters per die for single Channel SDRAM devices

Refresh Requirements		Symbol	2Gb	Units
Density per Channel			2Gb	
Number of banks per channel			8	
Refresh Window (tREFW) (TCASE ≤ 85°C)		tREFW	32	mS
Refresh Window (tREFW) (1/2 Rate Refresh)		tREFW	16	mS
Refresh Window (tREFW) (1/4 Rate Refresh)		tREFW	8	mS
Required Number of REFRESH Commands in a tREFW window		R	8192	-
Average Refresh Interval	REFAB	tREFI	3.904	μS
	REFPB	tREFIpb	488	nS
Refresh Cycle Time (All Banks)		tRFCab	130	nS
Refresh Cycle Time (Per Bank)		tRFCpb	60	nS
Per-bank Refresh to Per-bank Refresh different bank Time		tpbR2pbR	60	

**Note:**

- Refresh for each channel is independent of the other channel on the die, or other channels in a package. Power delivery in the user's system should be verified to make sure the DC operating conditions are maintained when multiple channels are refreshed simultaneously.



**7.4.21 Self Refresh Operation**

**7.4.21.1 Self Refresh Entry and Exit**

The Self Refresh command can be used to retain data in the LPDDR4X SDRAM; the SDRAM retains data without external Refresh command. The device has a built-in timer to accommodate Self Refresh operation. The Self Refresh is entered by Self Refresh Entry Command defined by having CS High, CA0 Low, CA1 Low, CA2 Low; CA3 High; CA4 High, CA5 Valid (Valid that means it is Logic Level, High or Low) for the first rising edge and CS Low, CA0 Valid, CA1 Valid, CA2 Valid, CA3 Valid, CA4 Valid, CA5 Valid at the second rising edge of the clock. Self Refresh command is only allowed when read data burst is completed and SDRAM is idle state.

During Self Refresh mode, external clock input is needed and all input pin of SDRAM are activated. SDRAM can accept the following commands, MRR-1, CAS-2, DES, SRX, MPC, MRW-1, and MRW-2 except PASR Bank/Segment setting.

LPDDR4X SDRAM can operate in Self Refresh in both the standard or elevated temperature ranges. SDRAM will also manage Self Refresh power consumption when the operating temperature changes, lower at low temperature and higher at high temperatures.

For proper Self Refresh operation, power supply pins (VDD1, VDD2 and VDDQ) must be at valid levels. However VDDQ may be turned off during Self Refresh with Power Down after tCKELCK (Max(5ns,5nCK)) is satisfied (Refresh to figure 72 about tCKELCK).

Prior to exiting Self Refresh with Power Down, VDDQ must be within specified limits. The minimum time that the SDRAM must remain in Self Refresh model is tSRmin. Once Self Refresh Exit is registered, only MRR-1, CAS-2, DES, MPC, MRW-1 and MRW-2 except PASR Bank/Segment setting are allowed until tXSR is satisfied.

The use of Self Refresh mode introduces the possibility that an internally timed refresh event can be missed when Self Refresh Exit is registered. Upon exit from Self Refresh, it is required that at least one REFRESH command (8 per bank or 1 all bank) is issued before entry into a subsequent Self Refresh.

This REFRESH command is not included in the count of regular refresh commands required by the tREFI interval, and does not modify the postponed or pulled-in refresh counts; the REFRESH command does count toward the maximum refreshes permitted within 2 x tREFI.

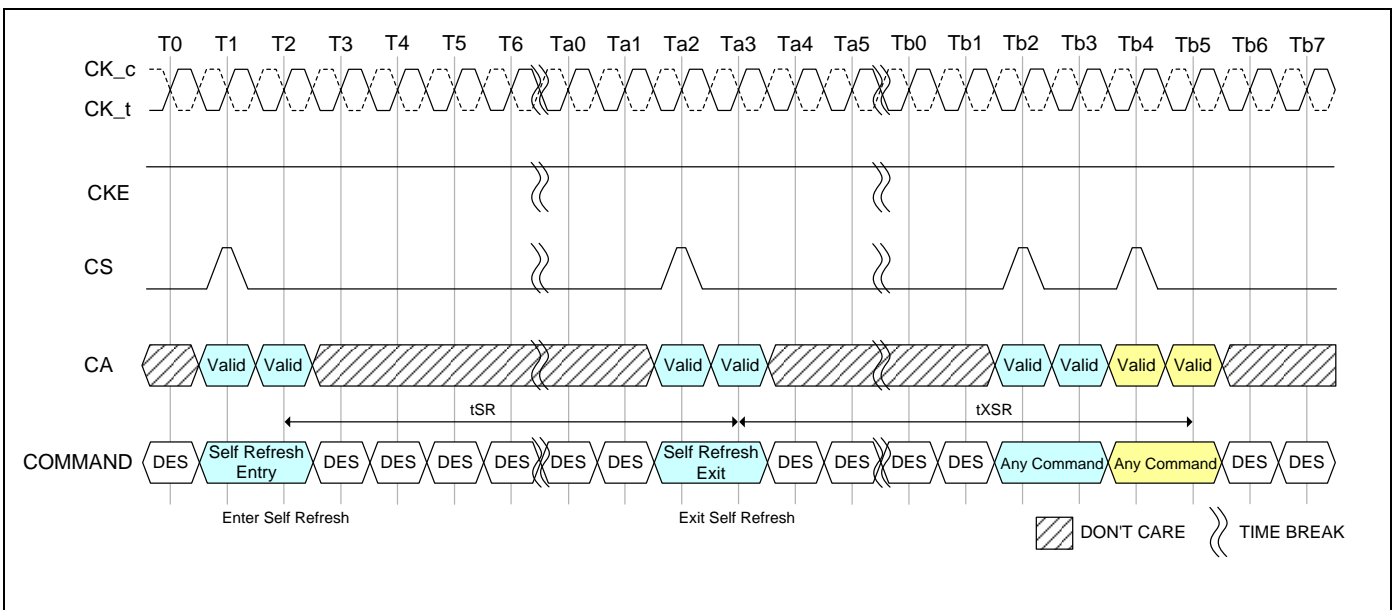

**Notes:**

1. MRR-1, CAS-2, DES, SRX, MPC, MRW-1 and MRW-2 except PASR Bank/Segment setting is allowed during Self Refresh.
2. DES commands are shown for ease of illustration; other commands may be valid at these times.

**Figure 71 - Self Refresh Entry/Exit Timing**





7.4.21.2 Power Down Entry and Exit during Self Refresh

Entering/Exiting Power Down Mode is allowed during Self Refresh mode in SDRAM. The related timing parameters between Self Refresh Entry/Exit and Power Down Entry/Exit are shown in Figure 72.

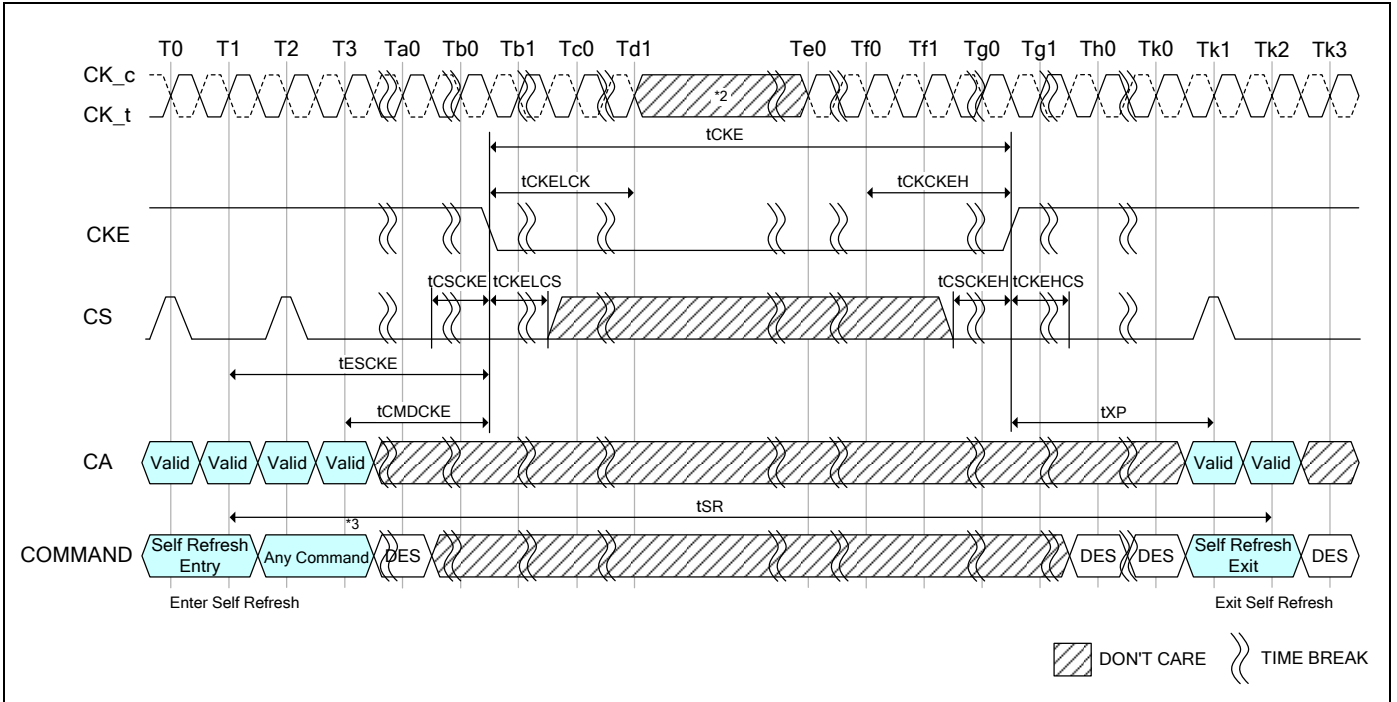

Notes:

1. MRR-1, CAS-2, DES, SRX, MPC, MRW-1 and MRW-2 except PASR Bank/Segment setting is allowed during Self Refresh.
2. Input clock frequency can be changed or the input clock can be stopped or floated after tCKELCK satisfied and during power-down, provided that upon exiting power-down, the clock is stable and within specified limits for a minimum of tCKCKEH of stable clock prior to power-down exit and the clock frequency is between the minimum and maximum specified frequency for the speed grade in use.
3. 2 Clock command for example.

Figure 72 - Self Refresh Entry/Exit Timing with Power Down Entry/Exit





7.4.21.3 Command input Timing after Power Down Exit

Command input timings after Power Down Exit during Self Refresh mode are shown in Figure 73.

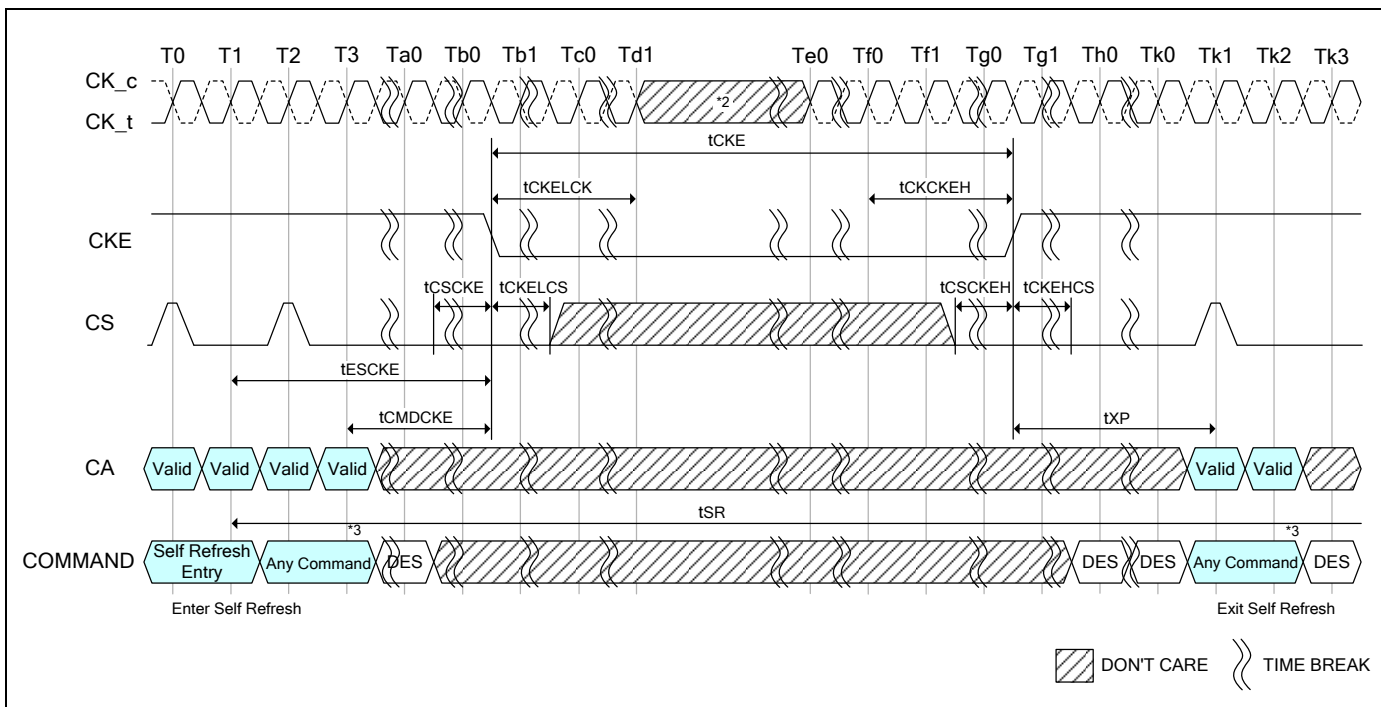

Notes:

1. MRR-1, CAS-2, DES, SRX, MPC, MRW-1 and MRW-2 except PASR Bank/Segment setting is allowed during Self Refresh.
2. Input clock frequency can be changed or the input clock can be stopped or floated after  $t_{CCKELCK}$  satisfied and during power-down, provided that upon exiting power-down, the clock is stable and within specified limits for a minimum of  $t_{CCKCKEH}$  of stable clock prior to power-down exit and the clock frequency is between the minimum and maximum specified frequency for the speed grade in use.
3. 2 Clock command for example.

Figure 73 - Command input timings after Power Down Exit during Self Refresh



7.4.21.4 AC Timing Table

Table 42 - AC Timing Table

Parameter	Symbol	Min/Max	Data Rate	Unit	Note
<b>Self Refresh Timing</b>					
Delay from SRE command to CKE Input low	tESCKE	Min	Max(1.75nS, 3tCK)	nS	1
Minimum Self Refresh Time	tSR	Min	Max(15nS, 3tCK)	nS	1
Exit Self Refresh to Valid commands	tXSR	Min	Max(tRFCab + 7.5nS, 2tCK)	nS	1, 2

Notes:

- Delay time has to satisfy both analog time (nS) and clock count (tCK). It means that tESCKE will not expire until CK has toggled through at least 3 full cycles (3 \* tCK) and 1.75nS has transpired. The case which 3tCK is applied to is shown in Figure 74.

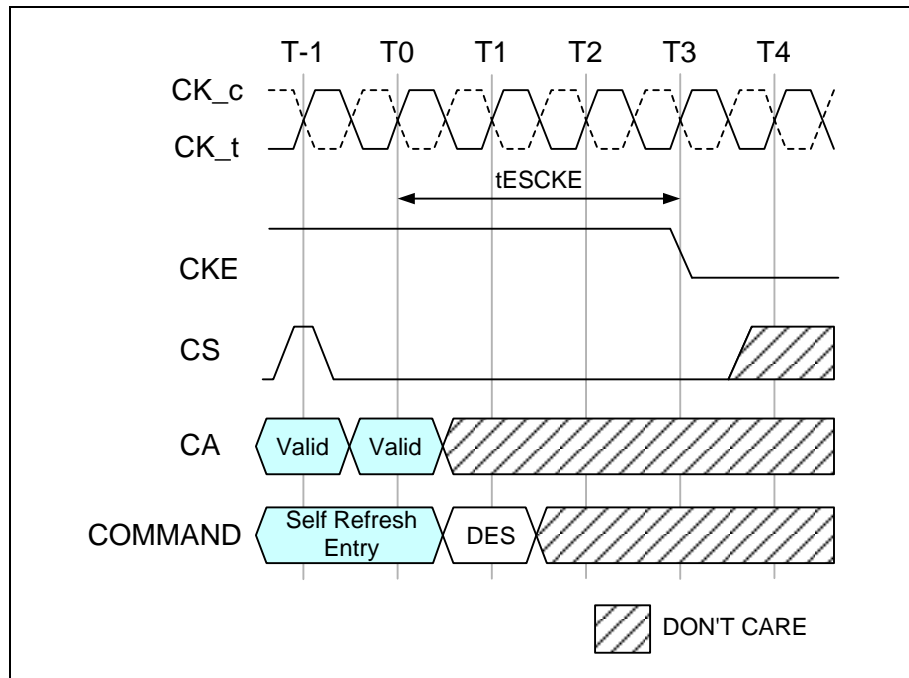

Figure 74 - tESCKE Timing

- MRR-1, CAS-2, DES, MPC, MRW-1 and MRW-2 except PASR Bank/Segment setting are only allowed during this period.



7.4.22 MRR, MRW, MPC Command during tXSR, tRFC

Mode Register Read (MRR), Multi-Purpose (MPC) and Mode Register Write (MRW) command except PASR Bank/Segment setting can be issued during tXSR period.

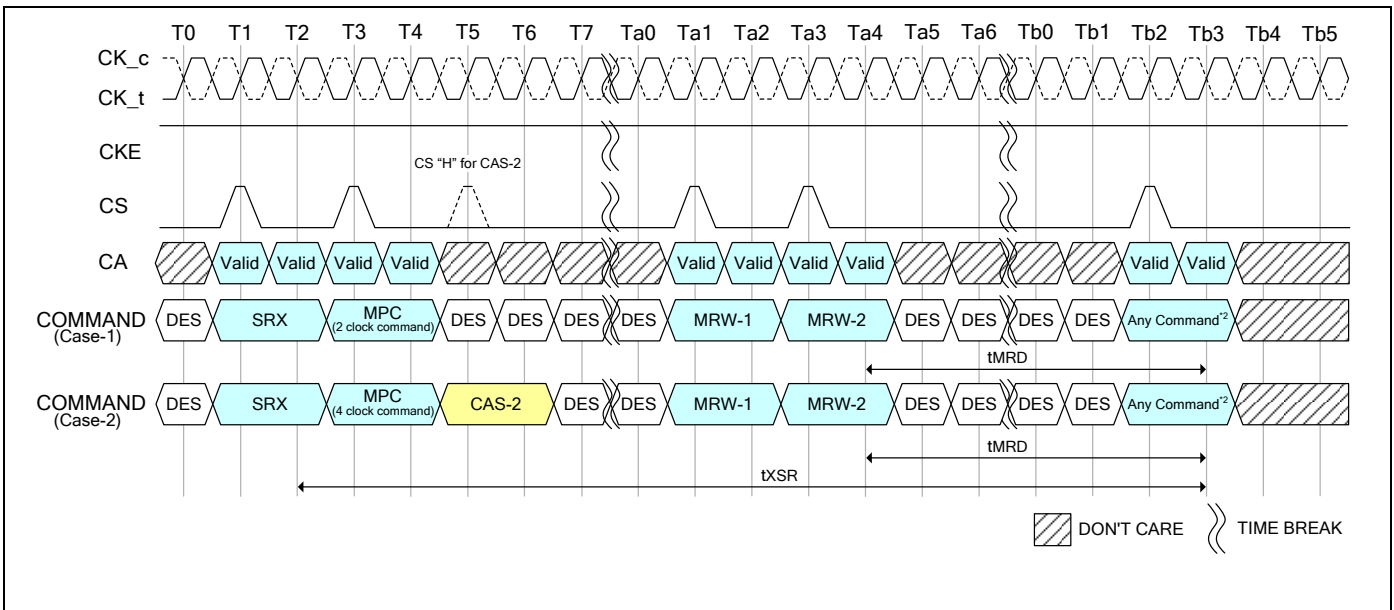

Notes:

1. MPC and MRW command are shown in figure at this time, any combination of MRR, MRW and MPC is allowed during tXSR period.
2. Any command also includes MRR, MRW and all MPC command.

Figure 75 - MRR, MRW and MPC Commands Issuing Timing during tXSR

Mode Register Read (MRR), Mode Register Write (MRW) and Multi-Purpose Command (MPC) can be issued during tRFC period.

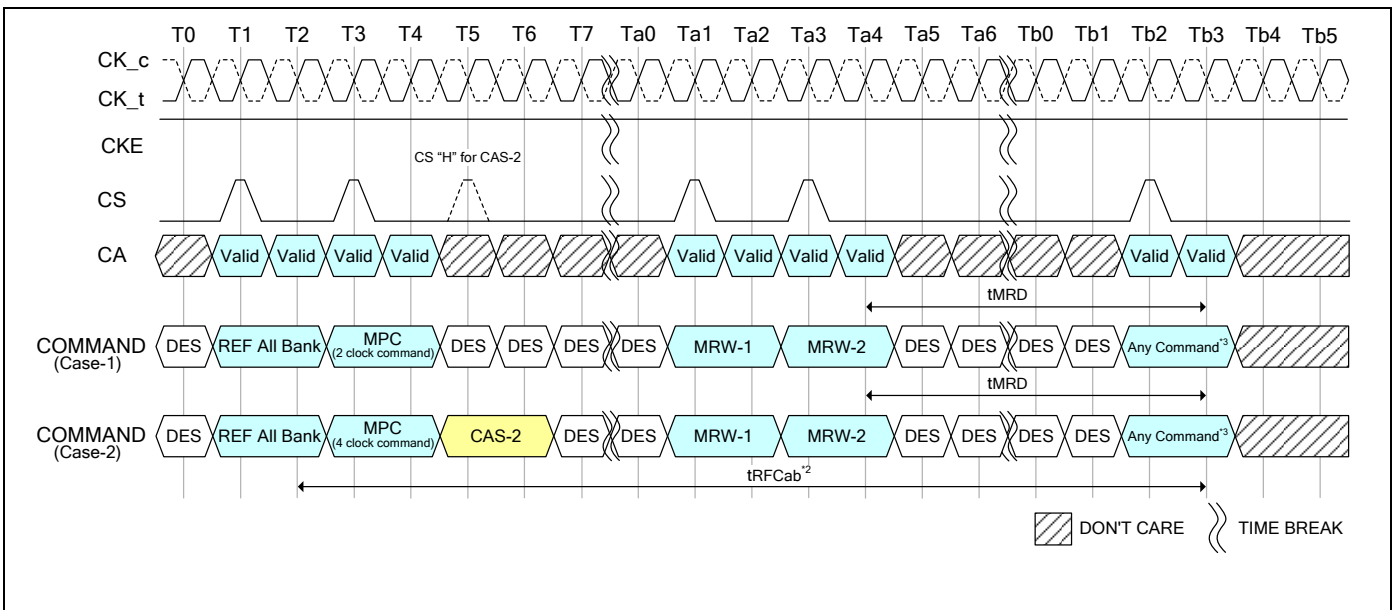

Notes:

1. MPC and MRW command are shown in figure at this time, any combination of MRR, MRW and MPC is allowed during tRFCab or tRFCpb period.
2. Refresh cycle time depends on Refresh command. In case of REF per Bank command issued, Refresh cycle time will be tRFCpb.
3. Any command also includes MRR, MRW and all MPC command.

Figure 76 - MRR, MRW and MPC Commands Issuing Timing during tRFC



### 7.4.23 MODE REGISTER READ (MRR)

The Mode Register Read (MRR) command is used to read configuration and status data from the LPDDR4X-SDRAM registers. The MRR command is initiated with CS and CA[5:0] in the proper state as defined by the Command Truth Table. The mode register address operands (MA[5:0]) allow the user to select one of 64 registers. The mode register contents are available on the first 4UI's data bits of DQ[7:0] after  $RL \times t_{CK} + t_{DQSCK} + t_{DQSQ}$  following the MRR command. Subsequent data bits contain valid but undefined content. DQS is toggled for the duration of the Mode Register READ burst. The MRR has a command burst length 16.

MRR operation must not be interrupted.

**Table 43 - DQ output mapping**

UI	0	1	2	3	4	5	6	7	8	9	10	11	12	13	14	15
DQ0	OP0			V												
DQ1	OP1			V												
DQ2	OP2			V												
DQ3	OP3			V												
DQ4	OP4			V												
DQ5	OP5			V												
DQ6	OP6			V												
DQ7	OP7			V												
DQ8-15	V								V							
DMI0-1	V								V							

**Notes:**

1. MRR data are extended to first 4 UI's for DRAM controller to sample data easily.
2. The read pre-amble and post-amble of MRR are same as normal read.

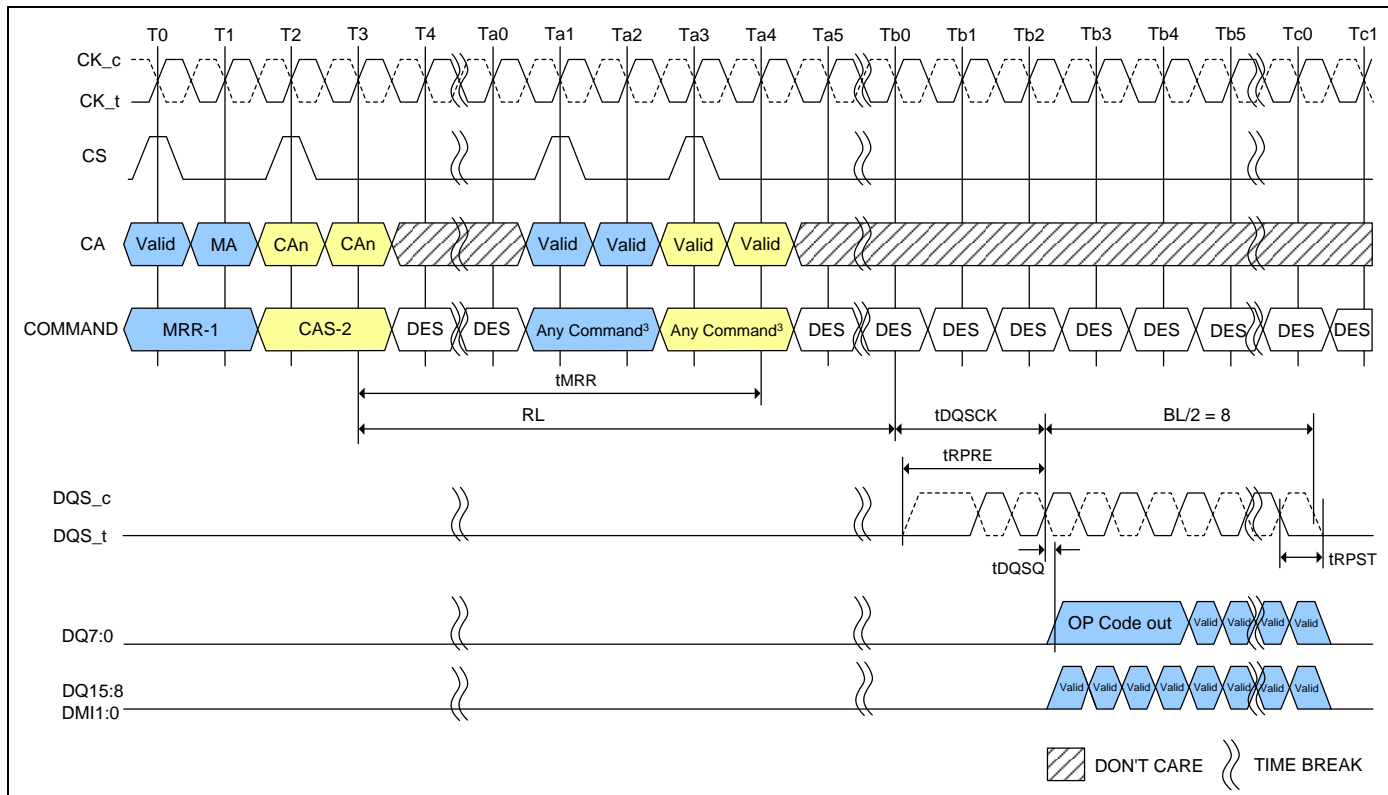

**Notes:**

1. Only BL=16 is supported.
2. Only DES is allowed during tMRR period.
3. There are some exceptions about issuing commands after tMRR. Refer to MRR/MRW Timing Constraints Table for detail.
4. DBI is Disable mode.
5. DES commands except tMRR period are shown for ease of illustration; other commands may be valid at these times.
6. DQ/DQS: VSSQ termination.

**Figure 77 - Mode Register Read Operation**



**7.4.23.1 MRR after Read and Write command**

After a prior READ command, the MRR command must not be issued earlier than BL/2 clock cycles, in a similar way WL + BL/2 + 1 + RU(tWTR/tCK) clock cycles after a prior Write, Write with AP, Mask Write, Mask Write with AP and MPC Write FIFO command in order to avoid the collision of Read and Write burst data on SDRAM's internal Data bus.

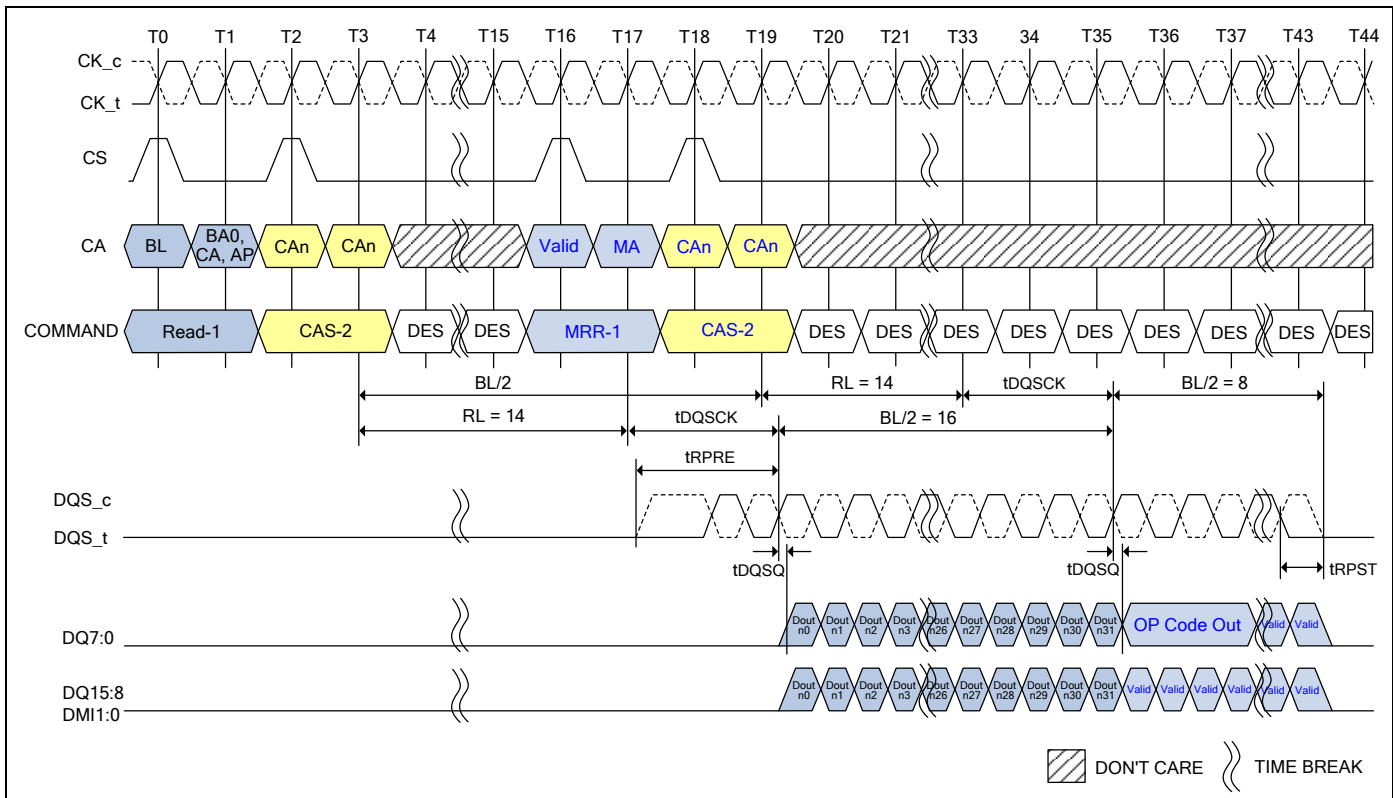

**Notes:**

1. The minimum number of clock cycles from the burst READ command to the MRR command is BL/2.
2. Read BL = 32, MRR BL = 16, RL = 14, Preamble = Toggle, Postamble = 0.5nCK, DBI = Disable, DQ/DQS: VSSQ termination.
3. DES commands except tMRR period are shown for ease of illustration; other commands may be valid at these times.

**Figure 78 - READ to MRR Timing**

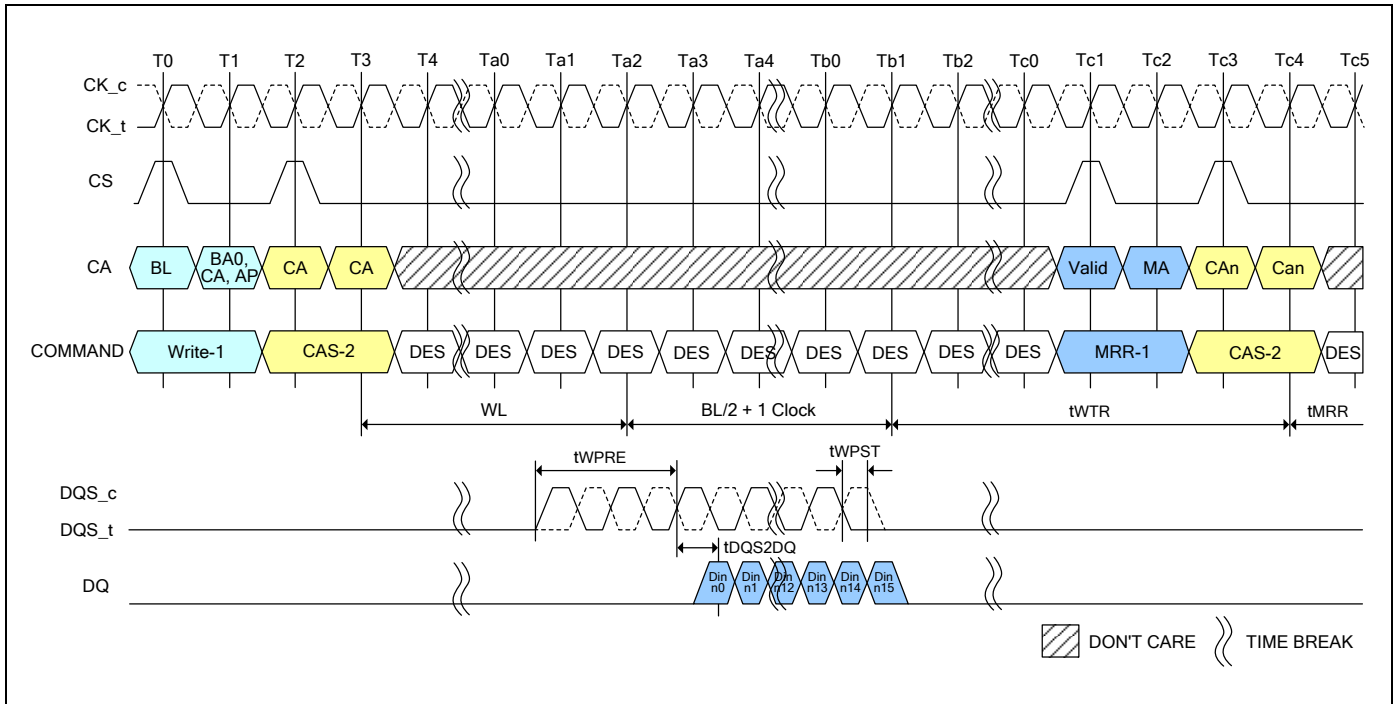

**Notes:**

1. Write BL=16, Write Postamble = 0.5nCK, DQ/DQS: VSSQ termination.
2. Only DES is allowed during tMRR period.
3. Din n = data-in to column n.
4. The minimum number of clock cycles from the burst write command to MRR command is  $WL + BL/2 + 1 + RU(tWTR/tCK)$ .
5. tWTR starts at the rising edge of CK after the last latching edge of DQS.
6. DES commands except tMRR period are shown for ease of illustration; other commands may be valid at these times.

**Figure 79 - Write to MRR Timing**



7.4.23.2 MRR after Power-Down Exit

Following the power-down state, an additional time, tMRRI, is required prior to issuing the mode register read (MRR) command. This additional time (equivalent to tRCD) is required in order to be able to maximize power-down current savings by allowing more power-up time for the MRR data path after exit from power down mode.

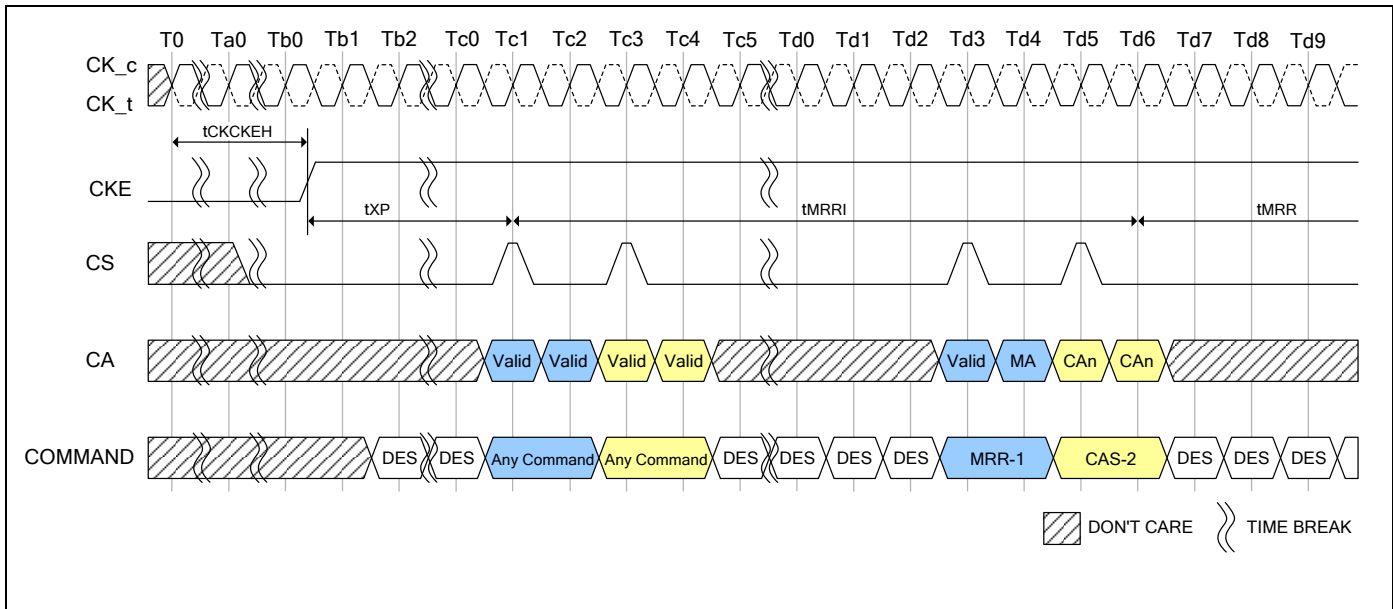

Notes:

1. Only DES is allowed during tMRR period.
2. DES commands except tMRR period are shown for ease of illustration; other commands may be valid at these times.

Figure 80 - MRR Following Power-Down

Table 44 - Mode Register Read/Write AC timing

Parameter	Symbol	Min/Max	Data Rate	Unit	Note
<b>Mode Register Read/Write Timing</b>					
Additional time after tXP has expired until MRR command may be issued	tMRRI	Min	tRCD + 3nCK	-	
MODE REGISTER READ command period	tMRR	Min	8	nCK	
MODE REGISTER WRITE command period	tMRW	Min	Max(10nS, 10nCK)	-	
Mode register set command delay	tMRD	Min	Max(14nS, 10nCK)	-	





**7.4.24 Mode Register Write (MRW) Operation**

The Mode Register Write (MRW) command is used to write configuration data to the mode registers. The MRW command is initiated by setting CKE, CS, and CA[5:0] to valid levels at a rising edge of the clock (see Command Truth Table). The mode register address and the data written to the mode registers is contained in CA[5:0] according to the Command Truth Table. The MRW command period is defined by tMRW. Mode register write to read-only registers have no impact on the functionality of the device.

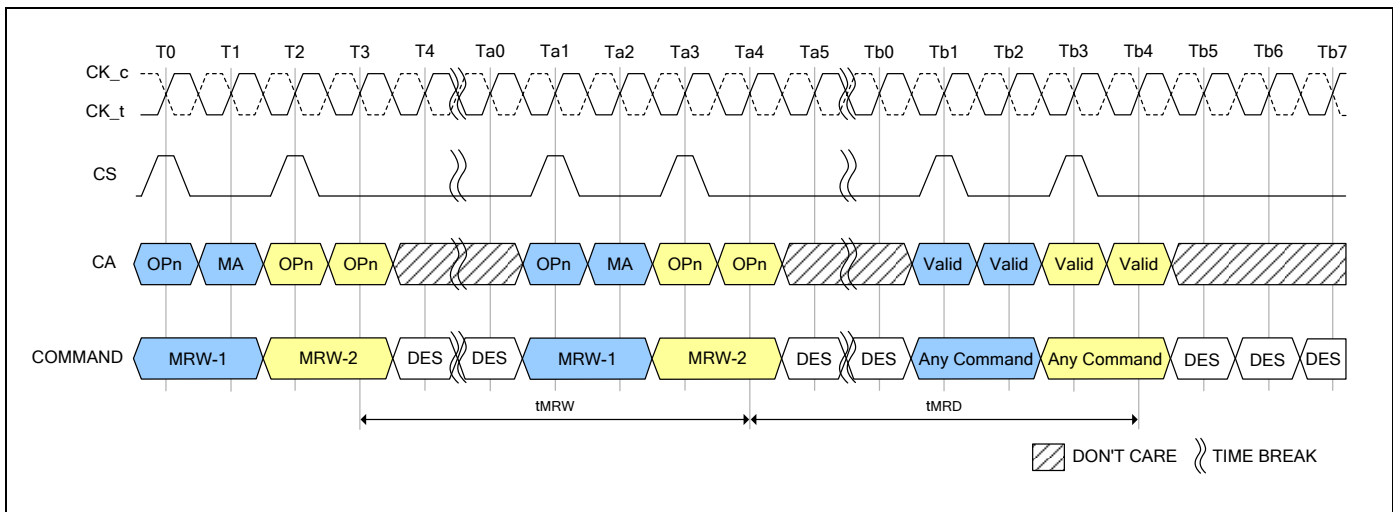

**Note:**

- 1. Only Deselect command is allowed during tMRW and tMRD periods.

**Figure 81 - Mode Register Write Timing**

**7.4.24.1 Mode Register Write**

MRW can be issued from either a Bank-Idle or Bank-Active state. Certain restrictions may apply for MRW from an Active state.

**Table 45 - Truth Table for Mode Register Read (MRR) and Mode Register Write (MRW)**

Current State	Command	Intermediate State	Next State
SDRAM		SDRAM	SDRAM
All Banks Idle	MRR	Mode Register Reading (All Banks Idle)	All Banks Idle
	MRW	Mode Register Writing (All Banks Idle)	All Banks Idle
Bank(s) Active	MRR	Mode Register Reading	Bank(s) Active
	MRW	Mode Register Writing	Bank(s) Active



Table 46 - MRR/MRW Timing Constraints: DQ ODT is Disable

From Command	To Command	Minimum Delay between "From Command" and "To Command"	Unit	Notes
MRR	MRR	tMRR	-	
	RD/RDA	tMRR	-	
	WR/WRA/MWR/MWRA	$RL+RU(tDQSCK(max)/tCK)+BL/2-WL+tWPRE+RD(tRPST)$	nCK	
	MRW	$RL+RU(tDQSCK(max)/tCK)+BL/2+3$	nCK	
RD/RDA	MRR	BL/2	nCK	
WR/WRA/MWR/MWRA		$WL+1+BL/2+RU(tWTR/tCK)$	nCK	
MRW		tMRD	-	
Power Down Exit		tXP+tMRRI	-	
MRW	RD/RDA	tMRD	-	
	WR/WRA/MWR/MWRA	tMRD	-	
	MRW	tMRW	-	
RD/RD FIFO/RD DQ CAL	MRW	$RL+BL/2+RU(tDQSCK_{max}/tCK) +RD(tRPST) +\max(RU(7.5nS/tCK),8nCK)$	nCK	
RD with Auto-Precharge		$RL+BL/2+RU(tDQSCK_{max}/tCK) +RD(tRPST) +\max(RU(7.5nS/tCK),8nCK)+nRTP-8$	nCK	
WR/MWR/WR FIFO		$WL+1+BL/2+\max(RU(7.5nS/tCK),8nCK)$	nCK	
WR/MWR with Auto-Precharge		$WL+1+BL/2+\max(RU(7.5nS/tCK),8nCK)+nWR$	nCK	

Table 47 - MRR/MRW Timing Constraints: DQ ODT is Enable

From Command	To Command	Minimum Delay between "From Command" and "To Command"	Unit	Notes
MRR	MRR	Same as ODT Disable Case	-	
	RD/RDA			
	WR/WRA/MWR/MWRA	$RL+RU(tDQSCK(max)/tCK)+BL/2-ODTLon-RD(tODTon(min)/tCK)+RD(tRPST)+1$	nCK	
	MRW	Same as ODT Disable Case	-	
RD/RDA	MRR	Same as ODT Disable Case	-	
WR/WRA/MWR/MWRA				
MRW				
Power Down Exit				
MRW	RD/RDA	Same as ODT Disable Case	-	
	WR/WRA/MWR/MWRA			
	MRW			
RD/RD FIFO/RD DQ CAL	MRW	Same as ODT Disable Case	-	
RD with Auto-Precharge				
WR/MWR/WR FIFO				
WR/MWR with Auto-Precharge				



**7.4.25 VREF Current Generator (VRCG)**

LPDDR4X SDRAM VREF current generators (VRCG) incorporate a high current mode to reduce the settling time of the internal VREF(DQ) and VREF(CA) levels during training and when changing frequency set points during operation. The high current mode is enabled by setting MR13[OP3] = 1. Only Deselect commands may be issued until tVRCG\_ENABLE is satisfied. tVRCG\_ENABLE timing is shown in Figure 82.

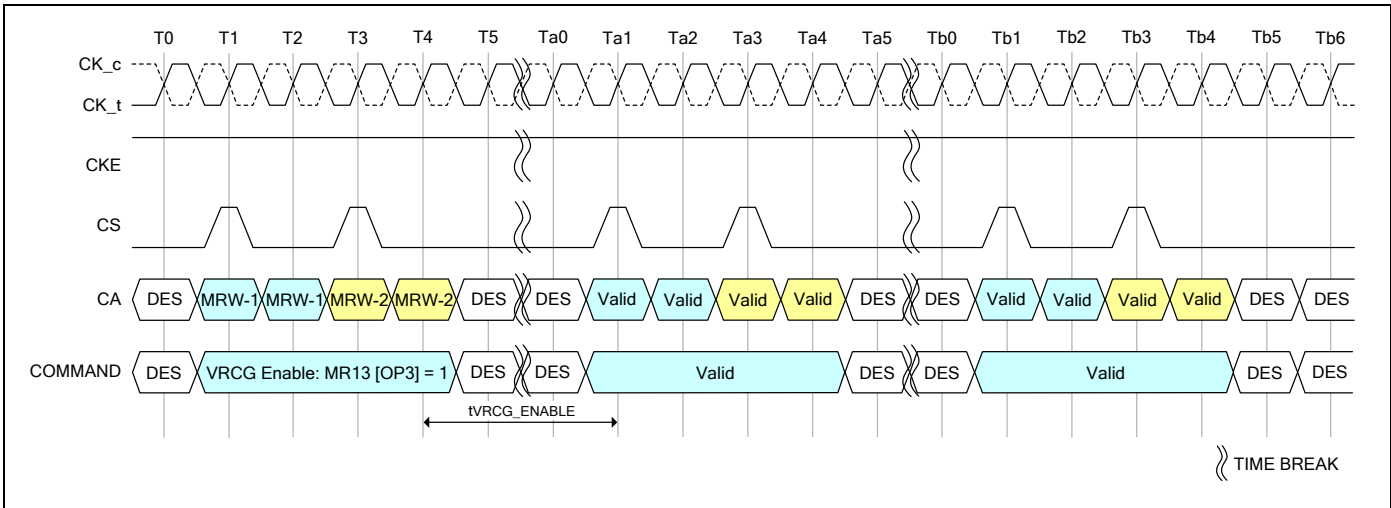

**Figure 82 - VRCG Enable timing**

VRCG high current mode is disabled by setting MR13[OP3] = 0. Only Deselect commands may be issued until tVRCG\_DISABLE is satisfied. tVRCG\_DISABLE timing is shown in Figure 83.

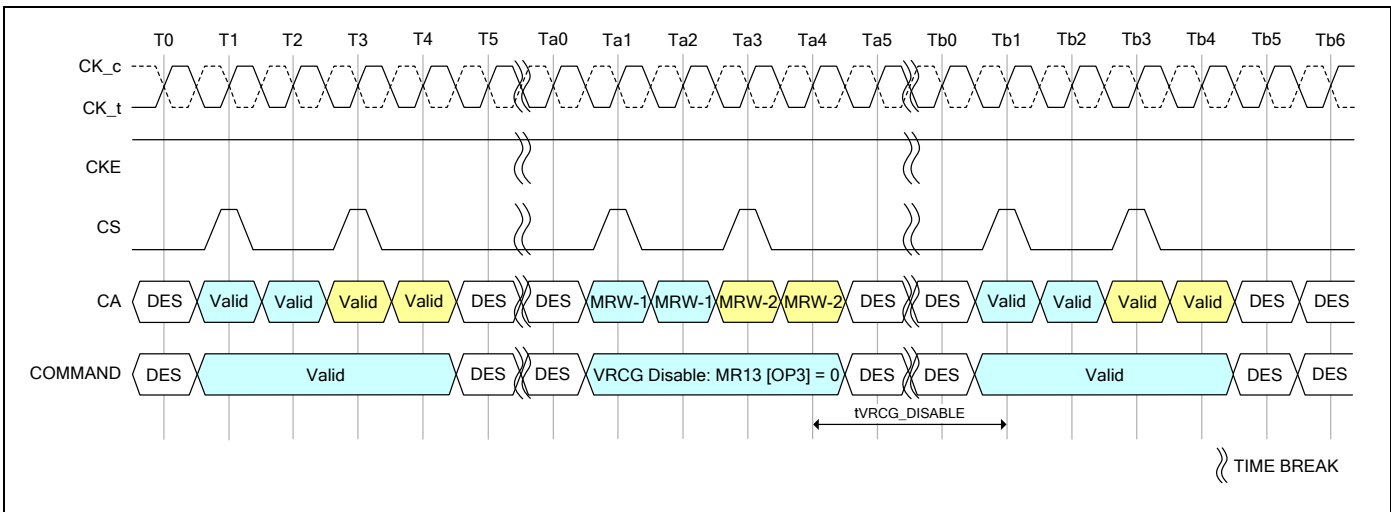

**Figure 83 - VRCG Disable timing**

Note that LPDDR4X SDRAM devices support VREF(CA) and VREF(DQ) range and value changes without enabling VRCG high current mode.

**Table 48 - VRCG Enable/Disable Timing**

Speed		533, 1066, 1600, 2133, 2667, 3200, 3733, 4267 Mbps		Units	Note
Parameter	Symbol	MIN	MAX		
VREF high current mode enable time	tVRCG_ENABLE	-	200	nS	
VREF high current mode disable time	tVRCG_DISABLE	-	100	nS	



**7.4.26 CA VREF Training**

The DRAM internal CA VREF specification parameters are voltage operating range, step size, VREF set tolerance, VREF step time and VREF valid level.

The voltage operating range specifies the minimum required VREF setting range for LPDDR4X DRAM devices. The minimum range is defined by VREFmax and VREFmin as depicted in Figure 84.

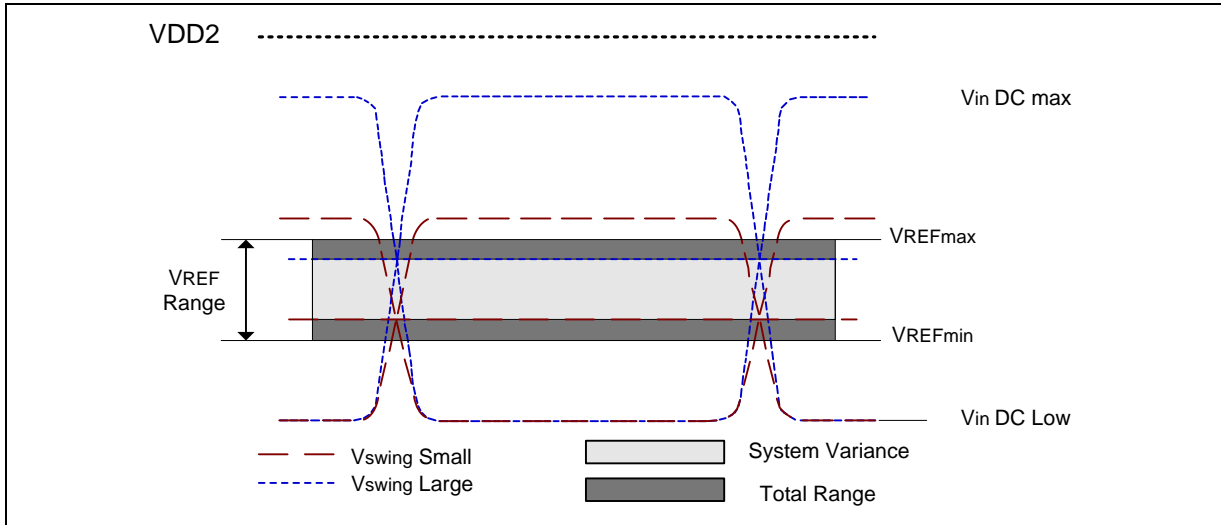
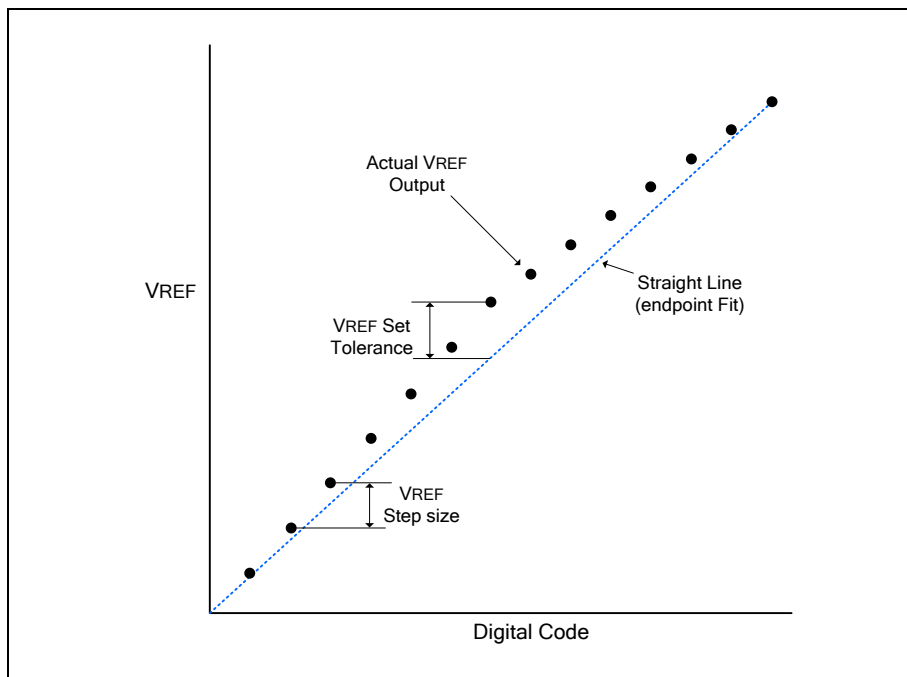

**Figure 84 - VREF operating range (VREFmin, VREFmax)**

The VREF step size is defined as the step size between adjacent steps. However, for a given design, DRAM has one value for VREF step size that falls within the range.

The VREF set tolerance is the variation in the VREF voltage from the ideal setting. This accounts for accumulated error over multiple steps. There are two ranges for VREF set tolerance uncertainty. The range of VREF set tolerance uncertainty is a function of number of steps n.

The VREF set tolerance is measured with respect to the ideal line which is based on the two endpoints. Where the endpoints are at the min and max VREF values for a specified range. An example of the step size and VREF set tolerance is shown in Figure 85.



**Figure 85 - Example of VREF set tolerance (max case only shown) and step size**



The VREF increment/decrement step times are define by VREF\_time-short, Middle and long. The VREF\_time-short, VREF\_time-Middle and VREF\_time-long is defined from TS to TE as shown in Figure 86 where TE is referenced to when the VREF voltage is at the final DC level within the VREF valid tolerance(VREF\_val\_tol).

The VREF valid level is defined by VREF\_val tolerance to qualify the step time TE as shown in Figure 86.

This parameter is used to insure an adequate RC time constant behavior of the voltage level change after any VREF increment/decrement adjustment. This parameter is only applicable for DRAM component level validation/characterization.

VREF\_time-Short is for a single step size increment/decrement change in VREF voltage.

VREF\_time-Middle is at least 2 step sizes increment/decrement change within the same VREFCA range in VREF voltage.

VREF\_time-Long is the time including up to VREFmin to VREFmax or VREFmax to VREFmin change across the VREFCA Range in VREF voltage.

TS - is referenced to MRS command clock

TE - is referenced to the VREF\_val\_tol

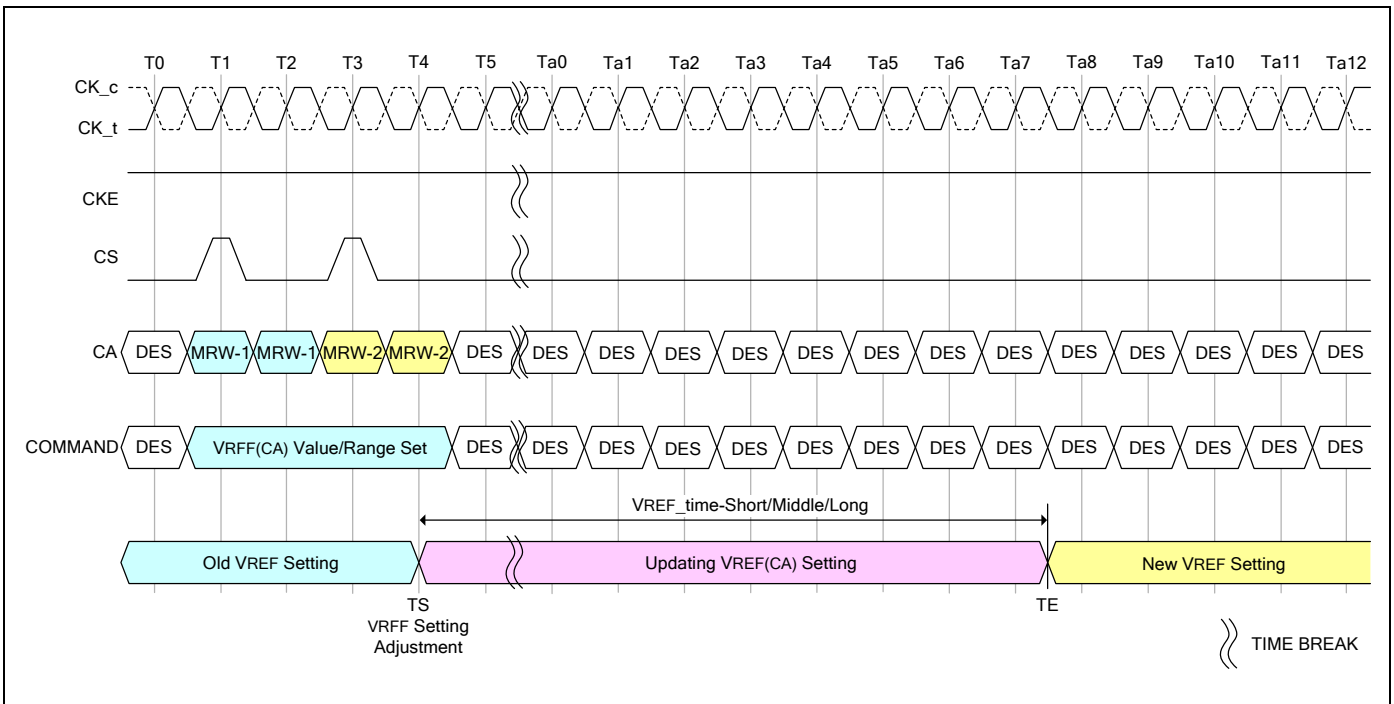

Figure 86 - VREF\_time for Short, Middle and Long Timing Diagram

The MRW command to the mode register bits are as follows.

MR12 OP[5:0]: VREF(CA) Setting

MR12 OP[6]: VREF(CA) Range



The minimum time required between two VREF MRS commands is VREF\_time-short for single step and VREF\_time-Middle for a full voltage range step.

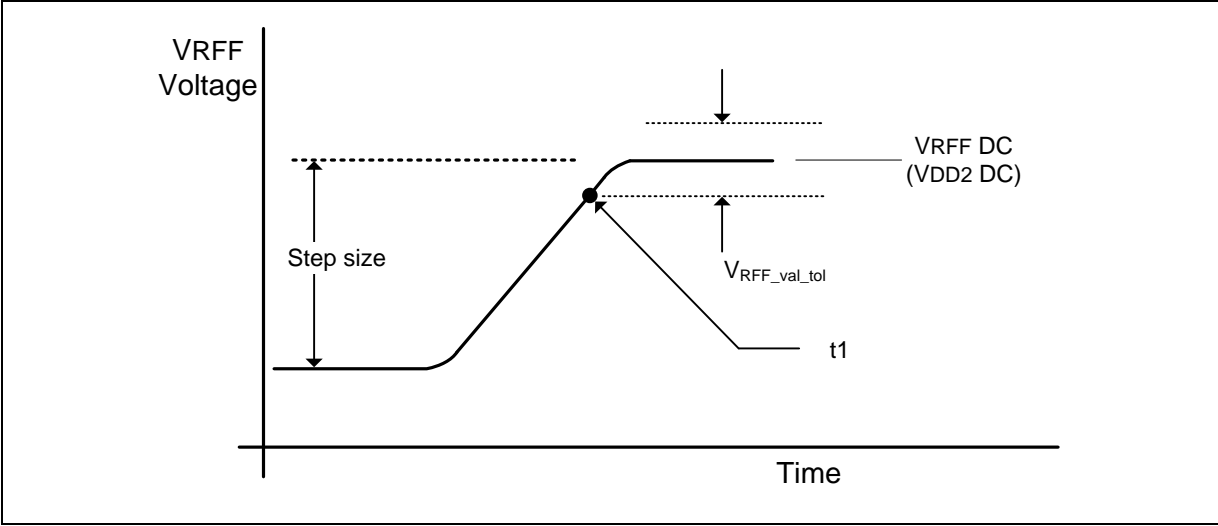

Figure 87 - VREF step single step size increment case

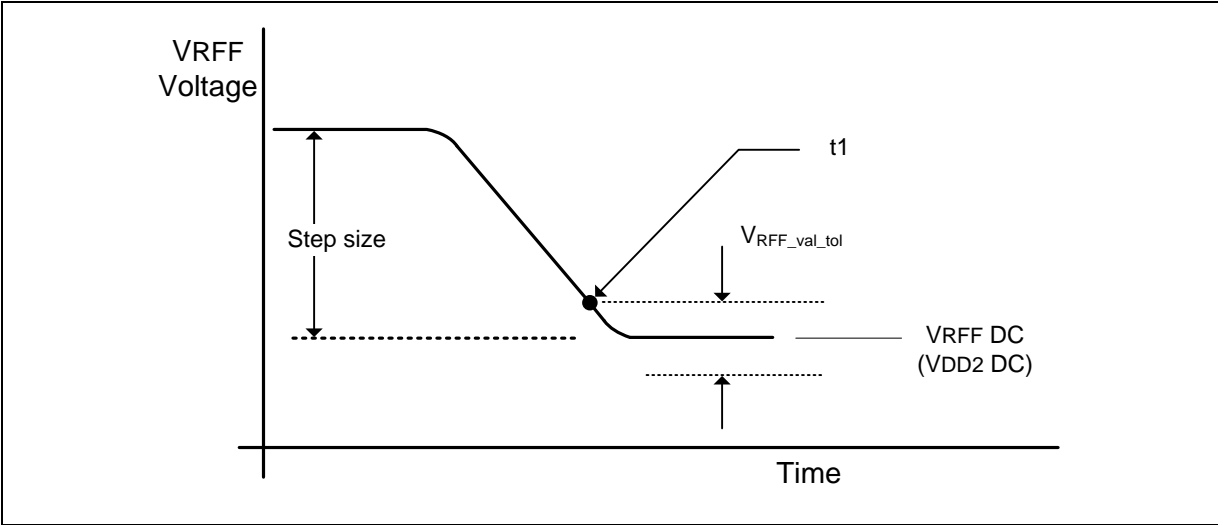

Figure 88 - VREF step single step size decrement case

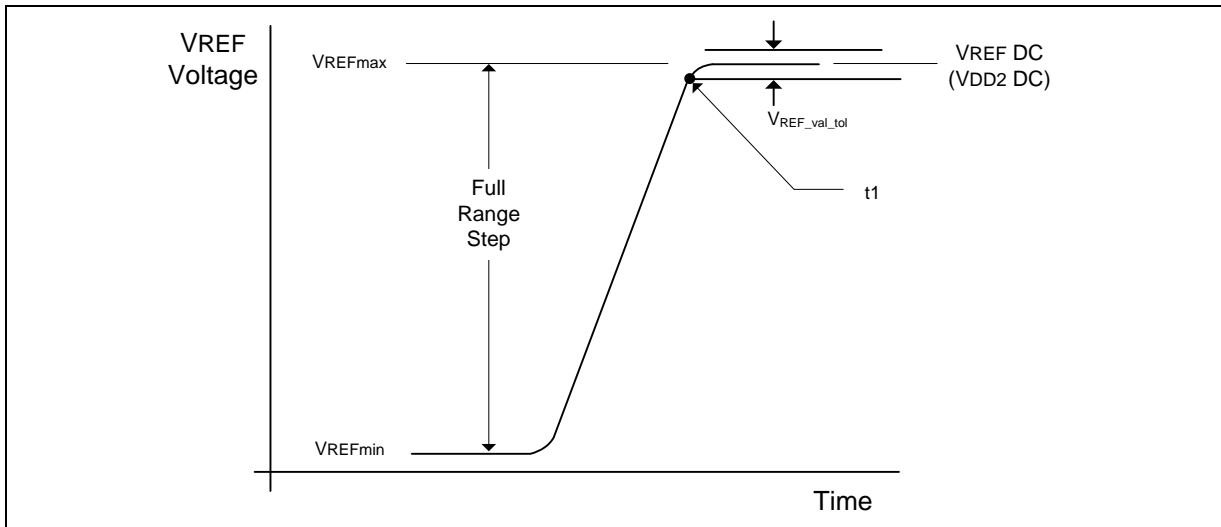

Figure 89 - VREF full step from VREFmin to VREFmax case

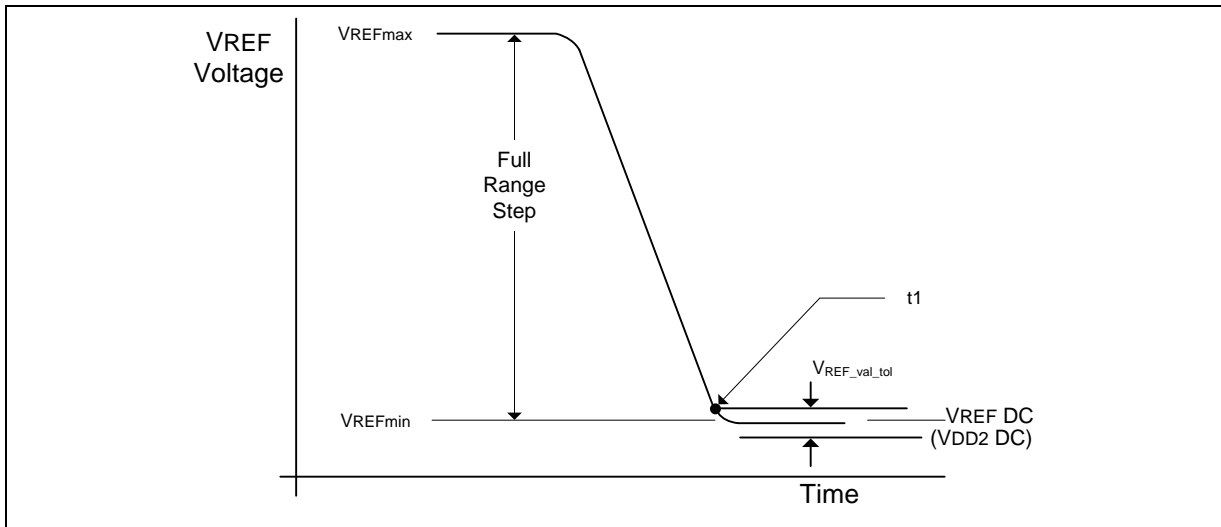

Figure 90 - VREF full step from VREFmax to VREFmin case



Table 49 - CA Internal VREF Specifications

Parameter	Symbol	Min	Typ	Max	Unit	Notes
VREF Max operating point Range0	VREF_max_R0	-	-	44.9%	VDDQ	1,11
VREF Min operating point Range0	VREF_min_R0	15%	-	-	VDDQ	1,11
VREF Max operating point Range1	VREF_max_R1	-	-	62.9%	VDDQ	1,11
VREF Min operating point Range1	VREF_min_R1	32.9%	-	-	VDDQ	1,11
VREF Step size	VREF step	0.50%	0.60%	0.70%	VDDQ	2
VREF Set Tolerance	VREF_set_tol	-11	0	11	mV	3,4,6
		-1.1	0	1.1	mV	3,4,7
VREF Step Time	VREF_time-Short	-	-	100	nS	8
	VREF_time_Middle	-	-	200	nS	12
	VREF_time-Long	-	-	250	nS	9
	VREF_time_weak	-	-	1	mS	13,14
VREF Valid tolerance	VREF_val_tol	-0.10%	0.00%	0.10%	VDDQ	10

**Notes:**

- VREF DC voltage referenced to VDD2\_DC.
- VREF step size increment/decrement range. VREF at DC level.
- $VREF_{new} = VREF_{old} + n * VREF_{step}$ ; n= number of steps; if increment use "+"; If decrement use "-".
- The minimum value of VREF setting tolerance =  $VREF_{new} - 11$  mV. The maximum value of VREF setting tolerance =  $VREF_{new} + 11$  mV. For  $n > 4$ .
- The minimum value of VREF setting tolerance =  $VREF_{new} - 1.1$  mV. The maximum value of VREF setting tolerance =  $VREF_{new} + 1.1$  mV. For  $n \leq 4$ .
- Measured by recording the min and max values of the VREF output over the range, drawing a straight line between those points and comparing all other VREF output settings to that line.
- Measured by recording the min and max values of the VREF output across 4 consecutive steps (n=4), drawing a straight line between those points and comparing all other VREF output settings to that line.
- Time from MRS command to increment or decrement one step size for VREF.
- Time from MRS command to increment or decrement VREFmin to VREFmax or VREFmax to VREFmin change across the VREFCA Range in VREF voltage.
- Only applicable for DRAM component level test/characterization purpose. Not applicable for normal mode of operation. VREF valid is to qualify the step times which will be characterized at the component level.
- DRAM range 0 or 1 set by MR12 OP[6].
- Time from MRS command to increment or decrement more than one step size up to a full range of VREF voltage within the same VREFCA range.
- Applies when VRCG high current mode is not enabled, specified by MR13[OP3] = 0.
- VREF\_time\_weak covers all VREF(CA) Range and Value change conditions are applied to VREF\_time\_Short/Middle/Long.





**7.4.27 DQ VREF Training**

The DRAM internal DQ VREF specification parameters are voltage operating range, step size, VREF set tolerance, VREF step time and VREF valid level.

The voltage operating range specifies the minimum required VREF setting range for LPDDR4X DRAM devices. The minimum range is defined by VREFmax and VREFmin as depicted in Figure 91.

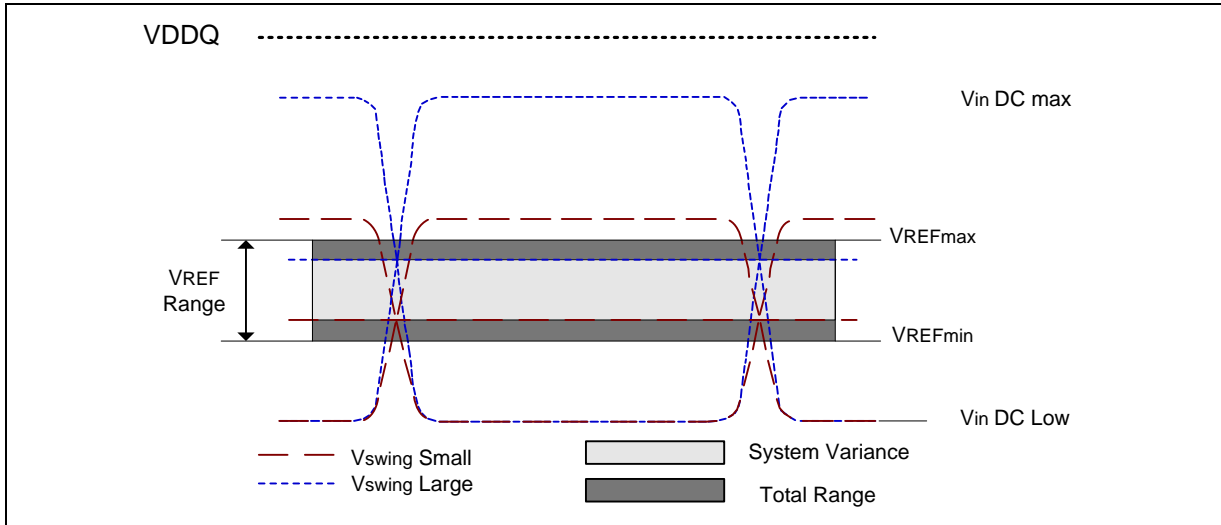
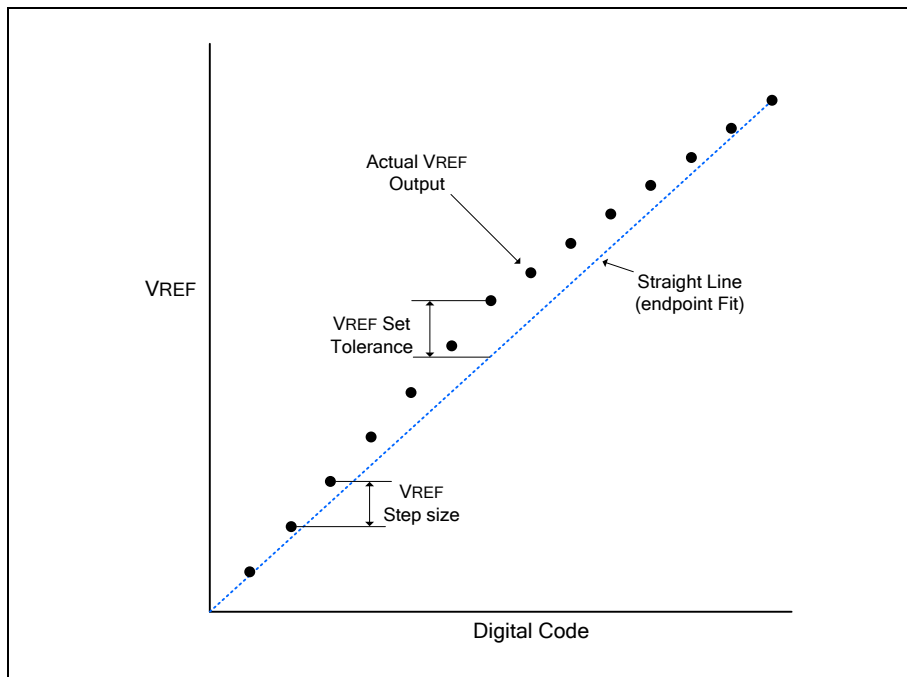

**Figure 91 - VREF operating range (VREFmin, VREFmax)**

The VREF step size is defined as the step size between adjacent steps. However, for a given design, DRAM has one value for VREF step size that falls within the range.

The VREF set tolerance is the variation in the VREF voltage from the ideal setting. This accounts for accumulated error over multiple steps. There are two ranges for VREF set tolerance uncertainty. The range of VREF set tolerance uncertainty is a function of number of steps n.

The VREF set tolerance is measured with respect to the ideal line which is based on the two endpoints. Where the endpoints are at the min and max VREF values for a specified range. An example of the step size and VREF set tolerance is shown in Figure 92.



**Figure 92 - Example of VREF set tolerance (max case only shown) and step size**



The VREF increment/decrement step times are define by VREF\_time-short, Middle and long. The VREF\_time-short, VREF\_time-Middle and VREF\_time-long is defined from TS to TE as shown in Figure 93 where TE is referenced to when the VREF voltage is at the final DC level within the VREF valid tolerance(VREF\_val\_tol).

The VREF valid level is defined by VREF\_val tolerance to qualify the step time TE as shown in Figure 93.

This parameter is used to insure an adequate RC time constant behavior of the voltage level change after any VREF increment/decrement adjustment. This parameter is only applicable for DRAM component level validation/characterization.

VREF\_time-Short is for a single step size increment/decrement change in VREF voltage.

VREF\_time-Middle is at least 2 step sizes increment/decrement change within the same VREFDQ range in VREF voltage.

VREF\_time-Long is the time including up to VREFmin to VREFmax or VREFmax to VREFmin change across the VREFDQ Range in VREF voltage.

TS - is referenced to MRS command clock

TE - is referenced to the VREF\_val\_tol

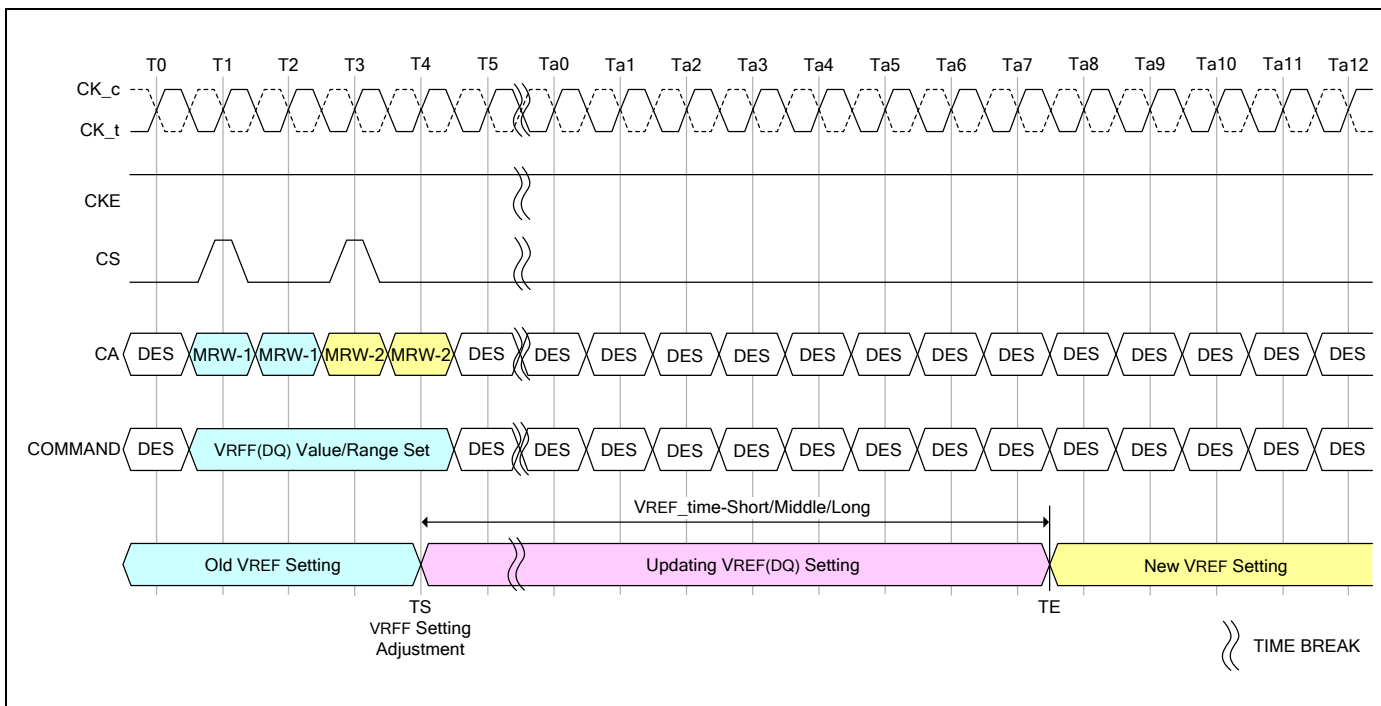

Figure 93 - VREF\_time for Short, Middle and Long Timing Diagram

The MRW command to the mode register bits are as follows.

MR14 OP[5:0]: VREF(DQ) Setting

MR14 OP[6]: VREF(DQ) Range



The minimum time required between two VREF MRS commands is VREF\_time-short for single step and VREF\_time-Middle for a full voltage range step.

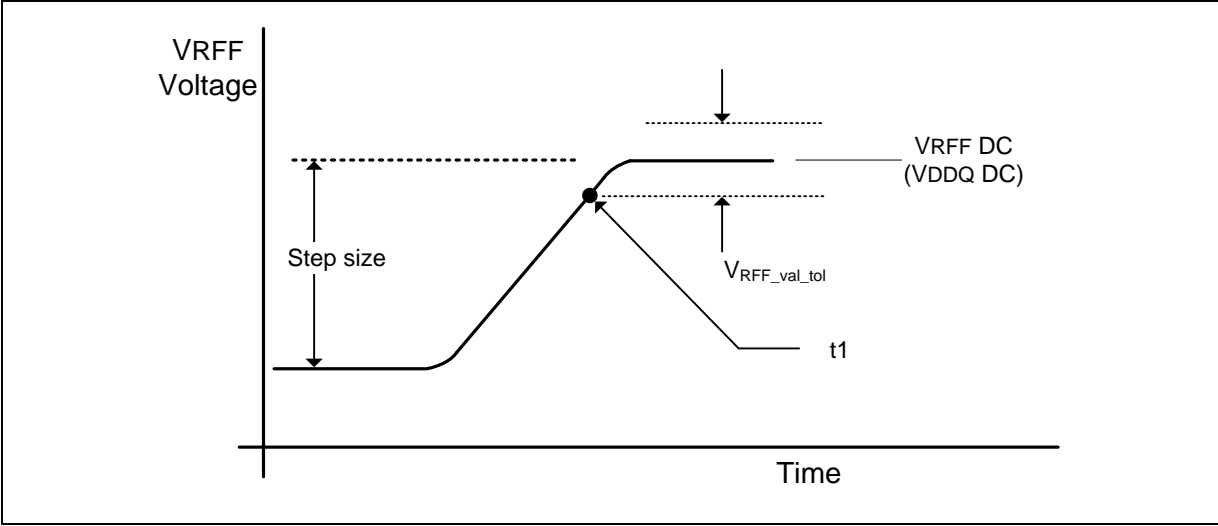

Figure 94 - VREF step single step size increment case

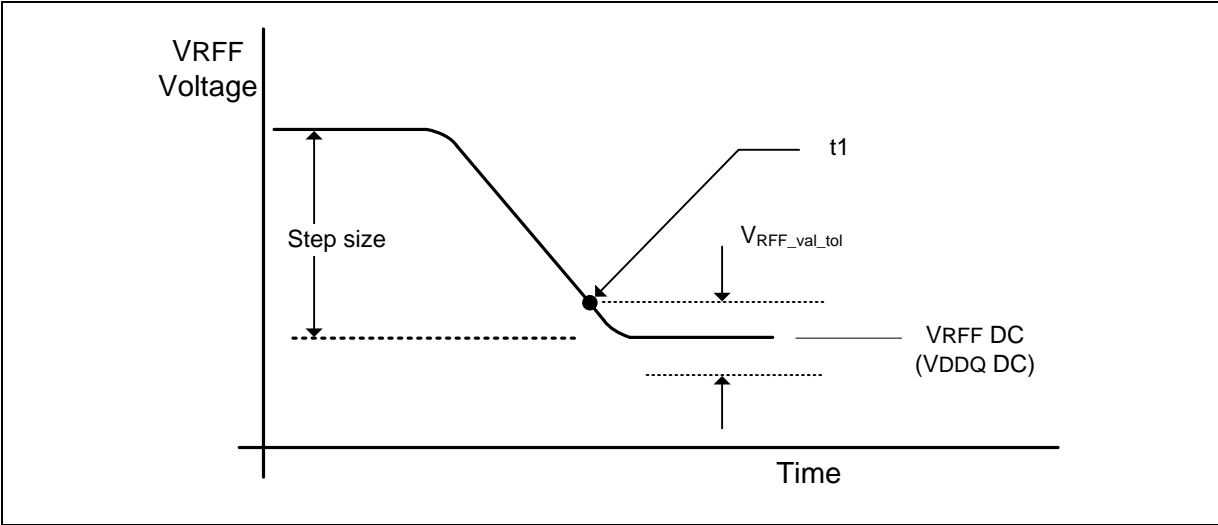

Figure 95 - VREF step single step size decrement case

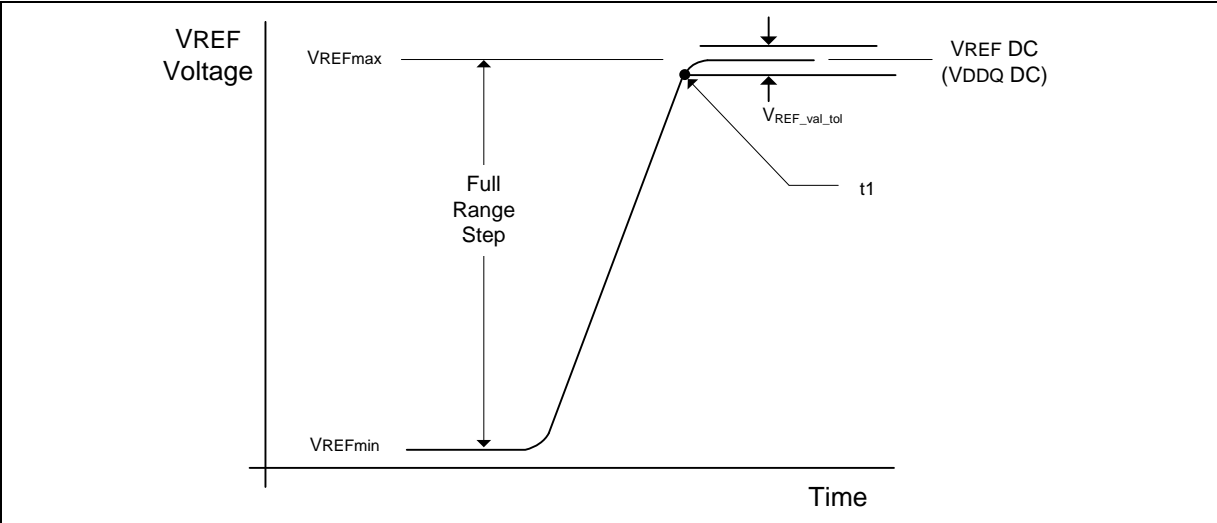

Figure 96 - VREF full step from VREFmin to VREFmax case

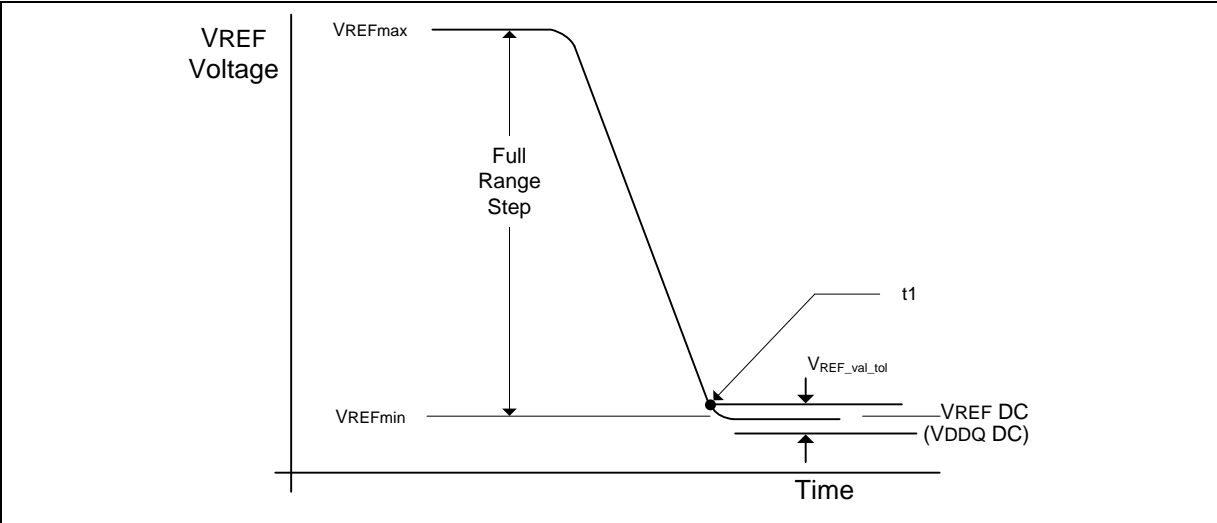

Figure 97 - VREF full step from VREFmax to VREFmin case



Table 50 - DQ Internal VREF Specifications

Parameter	Symbol	Min	Typ	Max	Unit	Notes
VREF Max operating point Range0	VREF_max_R0	-	-	44.9%	VDDQ	1,11
VREF Min operating point Range0	VREF_min_R0	15%	-	-	VDDQ	1,11
VREF Max operating point Range1	VREF_max_R1	-	-	62.9%	VDDQ	1,11
VREF Min operating point Range1	VREF_min_R1	32.9%	-	-	VDDQ	1,11
VREF Step size	VREF Step	0.50%	0.60%	0.70%	VDDQ	2
VREF Set Tolerance	VREF_set_tol	-11	0	11	mV	3,4,6
		-1.1	0	1.1	mV	3,4,7
VREF Step Time	VREF_time-Short	-	-	100	nS	8
	VREF_time_Middle	-	-	200	nS	12
	VREF_time-Long	-	-	250	nS	9
	VREF_time_weak	-	-	1	mS	13,14
VREF Valid tolerance	VREF_val_tol	-0.10%	0.00%	0.10%	VDDQ	10

**Notes:**

- VREF DC voltage referenced to VDDQ\_DC.
- VREF step size increment/decrement range. VREF at DC level.
- $VREF_{new} = VREF_{old} + n * VREF_{step}$ ; n= number of steps; if increment use "+"; If decrement use "-".
- The minimum value of VREF setting tolerance =  $VREF_{new} - 11$  mV. The maximum value of VREF setting tolerance =  $VREF_{new} + 11$  mV. For  $n > 4$ .
- The minimum value of VREF setting tolerance =  $VREF_{new} - 1.1$  mV. The maximum value of VREF setting tolerance =  $VREF_{new} + 1.1$  mV. For  $n \leq 4$ .
- Measured by recording the min and max values of the VREF output over the range, drawing a straight line between those points and comparing all other VREF output settings to that line.
- Measured by recording the min and max values of the VREF output across 4 consecutive steps ( $n=4$ ), drawing a straight line between those points and comparing all other VREF output settings to that line.
- Time from MRS command to increment or decrement one step size for VREF.
- Time from MRS command to increment or decrement VREFmin to VREFmax or VREFmax to VREFmin change across the VREFDQ Range in VREF voltage.
- Only applicable for DRAM component level test/characterization purpose. Not applicable for normal mode of operation. VREF valid is to qualify the step times which will be characterized at the component level.
- DRAM range 0 or 1 set by MR14 OP[6].
- Time from MRS command to increment or decrement more than one step size up to a full range of VREF voltage within the same VREFDQ range.
- Applies when VRCG high current mode is not enabled, specified by MR13[OP3] = 0.
- VREF\_time\_weak covers all VREF(DQ) Range and Value change conditions are applied to VREF\_time\_Short/Middle/Long.



### 7.4.28 Command Bus Training

The LPDDR4X-SDRAM command bus must be trained before enabling termination for high-frequency operation. LPDDR4X provides an internal VREF(CA) that defaults to a level suitable for un-terminated, low frequency operation, but the VREF(CA) must be trained to achieve suitable receiver voltage margin for terminated, high-frequency operation. The training mode described here centers the internal VREF(CA) in the CA data eye and at the same time allows for timing adjustments of the CS and CA signals to meet setup/hold requirements. Because it can be difficult to capture commands prior to training the CA inputs, the training mode described here uses a minimum of external commands to enter, train, and exit the Command Bus Training mode.

**NOTE:** It is up to the system designer to determine what constitutes “low-frequency” and “high-frequency” based on the capabilities of the system. Low-frequency should then be defined as an operating frequency in which the system can reliably communicate with the SDRAM before Command Bus Training is executed.

The LPDDR4X-SDRAM die has a bond pad (ODT\_CA) for multi-rank operation. In a multi-rank system, the terminating rank should be trained first, followed by the non-terminating rank(s). See 7.4.40.1, ODT section for more information.

The LPDDR4X-SDRAM uses Frequency Set-Points to enable multiple operating settings for the die. The LPDDR4X-SDRAM defaults to FSP-OP[0] at power-up, which has the default settings to operate in unterminated, low-frequency environments. Prior to training, the mode register settings should be configured by setting MR13 OP[6]=1B (FSP-WR[1]) and setting all other mode register bits for FSP-OP[1] to the desired settings for high-frequency operation. Prior to entering Command Bus Training, the SDRAM will be operating from FSP-OP[x]. Upon Command Bus Training entry when CKE is driven LOW, the LPDDR4X-SDRAM will automatically switch to the alternate FSP register set (FSP-OP[y]) and use the alternate register settings during training (See note 6 in Figure 99 for more information on FSP-OP register sets). Upon training exit when CKE is driven HIGH, the LPDDR4X-SDRAM will automatically switch back to the original FSP register set (FSP-OP[x]), returning to the “known-good” state that was operating prior to training. The training values for VREF(CA) are not retained by the DRAM in FSP-OP[y] registers, and must be written to the registers after training exit.

1. To enter Command Bus Training mode, issue a MRW-1 command followed by a MRW-2 command to set MR13 OP[0]=1B (Command Bus Training Mode Enabled).
2. After time tMRD, CKE may be set LOW, causing the LPDDR4X-SDRAM to switch from FSP-OP[x] to FSP-OP[y], and completing the entry into Command Bus Training mode.

A status of DQS\_t, DQS\_c, DQ and DMI are as follows, and DQ ODT state will be followed Frequency Set Point function except output pins.

- DQS\_t[0], DQS\_c[0] become input pins for capturing DQ[6:0] levels by its toggling.
  - DQ[5:0] become input pins for setting VREF(CA) Level.
  - DQ[6] becomes input pin for setting VREF(CA) Range.
  - DQ[7] and DMI[0] become input pins and their input level is Valid level or floating, either way is fine.
  - DQ[13:8] become output pins to feedback its capturing value via command bus by CS signal.
  - DQS\_t[1], DQS\_c[1], DMI[1] and DQ[15:14] become output pins or disable, it means that SDRAM may drive to a valid level or left floating.
3. At time tCAENT later, LPDDR4X SDRAM can accept to change its VREF(CA) Range and Value using input signals of DQS\_t[0], DQS\_c[0] and DQ[6:0] from existing value that's setting via MR12 OP[6:0]. The mapping between MR12 OP code and DQs is shown in Table 51. At least one VREFCA setting is required before proceed to next training steps.



Table 51 - Mapping of MR12 OP Code and DQ Numbers

	Mapping						
MR12 OP Code	OP6	OP5	OP4	OP3	OP2	OP1	OP0
DQ Number	DQ6	DQ5	DQ4	DQ3	DQ2	DQ1	DQ0

- The new VREF(CA) value must “settle” for time tVREF\_LONG before attempting to latch CA information.
- To verify that the receiver has the correct VREF(CA) setting and to further train the CA eye relative to clock (CK), values latched at the receiver on the CA bus are asynchronously output to the DQ bus.
- To exit Command Bus Training mode, drive CKE HIGH, and after time tVREF\_LONG issue the MRW-1 command followed by the MRW-2 command to set MR13 OP[0]=0B. After time tMRW the LPDDR4X-SDRAM is ready for normal operation. After training exit the LPDDR4X-SDRAM will automatically switch back to the FSP-OP registers that were in use prior to training.

Command Bus Training may be executed from IDLE or Self Refresh states. When executing CBT within the Self Refresh state, the SDRAM must not be a power down state (i.e., CKE must be HIGH prior to training entry). Command Bus Training entry and exit is the same, regardless of the SDRAM state from which CBT is initiated.

#### 7.4.28.1 Training Sequence for single-rank systems

Note that an example shown here is assuming an initial low-frequency, no-terminating operating point, training a high-frequency, terminating operating point. **The green text is low-frequency, magenta text is high-frequency.** Any operating point may be trained from any known good operating point.

- Set MR13 OP[6]=1B to enable writing to Frequency Set Point 'y' (FSP-WR[y]) (or FSP-OP[x]).
- Write FSP-WR[y] (or FSP-WR[x]) registers for all channels to set up high-frequency operating parameters.
- Issue MRW-1 and MRW-2 commands to enter Command Bus Training mode.
- Drive CKE LOW, and change CK frequency to the high-frequency operating point.
- Perform Command Bus Training (VREFCA, CS, and CA).
- Exit training, a change CK frequency to the low-frequency operating point prior to driving CKE HIGH, then issue MRW-1 and MRW-2 commands. When CKE is driven HIGH, the SDRAM will automatically switch back to the FSP-OP registers that were in use prior to training (i.e., trained values are not retained by the SDRAM).
- Write the trained values to FSP-WR[y] (or FSP-WR[x]) by issuing MRW-1 and MRW-2 commands to the SDRAM and setting all applicable mode register parameters.
- Issue MRW-1 and MRW-2 commands to switch to FSP-OP[y] (or FSP-OP[x]), to turn on termination, and change CK frequency to the high frequency operating point. At this point the Command Bus is trained and you may proceed to other training or normal operation.

#### 7.4.28.2 Training Sequence for multi-rank systems

Note that an example shown here is assuming an initial low-frequency, no-terminating operating point, training a high-frequency, terminating operating point. **The green text is low-frequency, magenta text is high-frequency.** Any operating point may be trained from any known good operating point.

- Set MR13 OP[6]=1B to enable writing to Frequency Set Point 'y' (FSP-WR[y]) (or FSP-WR[x]).
- Write FSP-WR[y] (or FSP-WR[x]) registers for all channels and ranks to set up high frequency operating parameters.
- Read MR0 OP[7] on all channels and ranks to determine which die are terminating, signified by MR0 OP[7]=1B.
- Issue MRW-1 and MRW-2 commands to enter Command Bus Training mode on the terminating rank.





5. Drive CKE LOW on the terminating rank (or all ranks), and change CK frequency to the high-frequency operating point.
6. Perform Command Bus Training on the terminating rank (VREFCA, CS, and CA).
7. Exit training by driving CKE HIGH, change CK frequency to the low-frequency operating point, and issue MRW-1 and MRW-2 commands to write the trained values to FSP-W[y] (or FSP-WR[x]). When CKE is driven HIGH, the SDRAM will automatically switch back to the FSP-OP registers that were in use prior to training (i.e., trained values are not retained by the SDRAM).
8. Issue MRW-1 and MRW-2 command to enter training mode on the non-terminating rank (but keep CKE HIGH)
9. Issue MRW-1 and MRW-2 commands to switch the terminating rank to FSP-OP[y] (or FSP-OP[x]), to turn on termination, and change CK frequency to the high frequency operating point.
10. Drive CKE LOW on the non-terminating (or all) ranks. The non-terminating rank(s) will now be using FSP-OP[y] (or FSP-OP[x]).
11. Perform Command Bus Training on the non-terminating rank (VREFCA, CS, and CA).
12. Issue MRW-1 and MRW-2 commands to switch the terminating rank to FSP-OP[x] (or FSP-OP[y]) to turn off termination.
13. Exit training by driving CKE HIGH on the non-terminating rank, change CK frequency to the low frequency operating point, and issue MRW-1 and MRW-2 commands. When CKE is driven HIGH, the SDRAM will automatically switch back to the FSP-OP registers that were in use prior to training (i.e., trained values are not retained by the SDRAM).
14. Write the trained values to FSP-WR[y] (or FSP-WR[x]) by issuing MRW-1 and MRW-2 commands to the SDRAM and setting all applicable mode register parameters.
15. Issue MRW-1 and MRW-2 commands to switch the terminating rank to FSP-OP[y] (or FSP-OP[x]), to turn on termination, and change CK frequency to the high frequency operating point. At this point the Command Bus is trained for both ranks and you may proceed to other training or normal operation.

#### 7.4.28.3 Relation between CA input pin DQ output pin

The relation between CA input pin DQ output pin is shown in Table 52.

**Table 52 - Mapping of CA Input pin and DQ Output pin**

	Mapping					
CA Number	CA5	CA4	CA3	CA2	CA1	CA0
DQ Number	DQ13	DQ12	DQ11	DQ10	DQ9	DQ8

#### 7.4.28.4 Timing Diagram

The basic Timing diagrams of Command Bus Training are shown in Figure 98, Figure 99, Figure 100, and Figure 101.



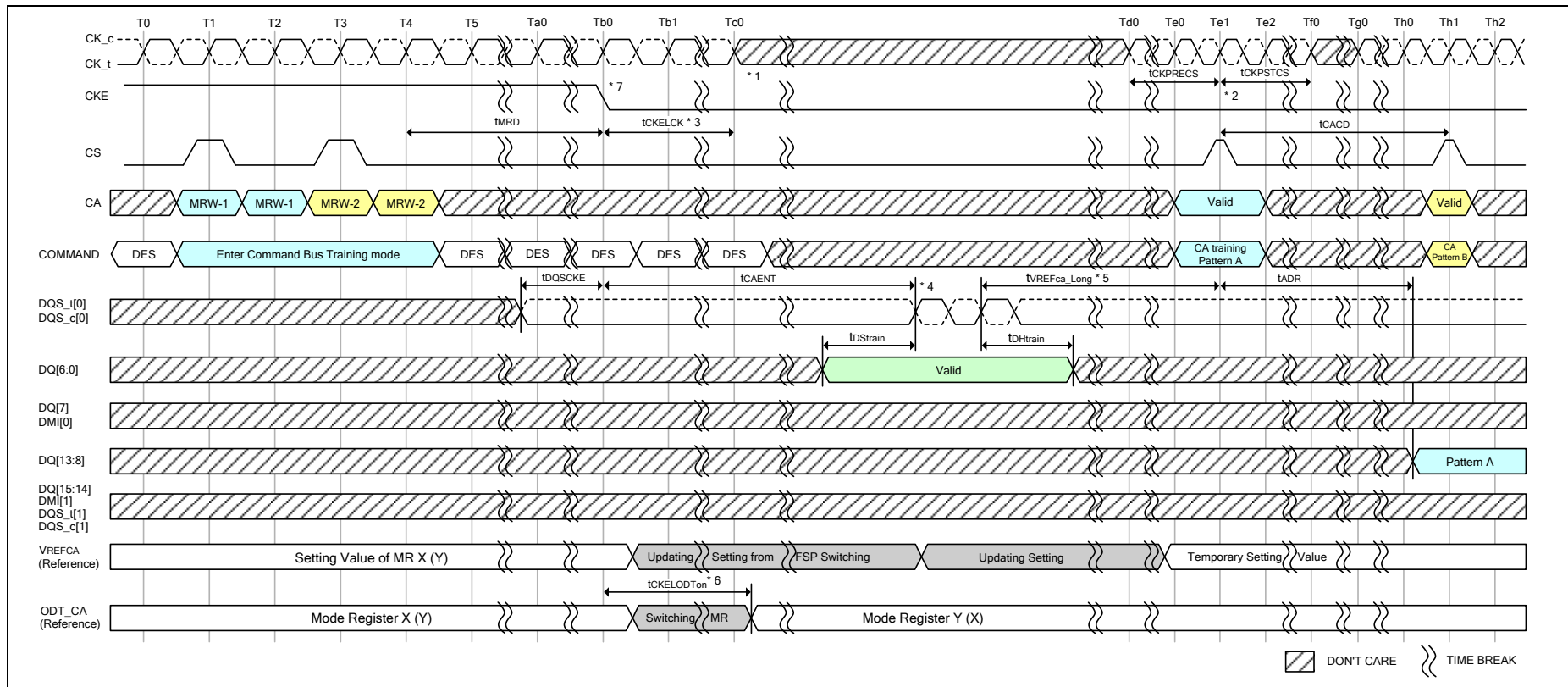

**Notes:**

1. After tCKELCK clock can be stopped or frequency changed any time.
2. The input clock condition should be satisfied tCKPRECS and tCKPSTCS.
3. Continue to Drive CK and Hold CS pins low until tCKELCK after CKE is low (which disables command decoding).
4. DRAM may or may not capture first rising/falling edge of DQS\_t/c due to an unstable first rising edge. Hence provide at least consecutive 2 pulses of DQS signal input is required in every DQS input signal at capturing DQ[6:0] signals. The captured value of DQ[6:0] signal level by each DQS edges are overwritten at any time and the DRAM updates its VREFCA setting of MR12 temporary after time tVREFca\_Long.
5. tVREF\_LONG may be reduced to tVREF\_SHORT if the following conditions are met: 1) The new VREF setting is a single step above or below the old VREF setting, and 2) The DQS pulses a single time, or the new VREF setting value on DQ[6:0] is static and meets tDStrain/tDHtrain for every DQS pulse applied.
6. When CKE is driven low, the SDRAM will switch its FSP-OP registers to use the alternate (i.e. non-active) set. Example: If the SDRAM is currently using FSP-OP[0], then it will switch to FSP-OP[1] when CKE is driven LOW. All operating parameters should be written to the alternate mode registers before entering Command Bus Training to ensure that ODT settings, RL/WL/nWR setting, etc., are set to the correct values. If the alternate FSP-OP has ODT\_CA disabled then termination will not enable in CA Bus Training mode. If the ODT\_CA pad is bonded to VSS, ODT\_CA termination will never enable for that die.
7. When CKE is driven low in Command Bus Training mode, the LPDDR4X SDRAM will change operation to the alternate FSP, i.e. the inverse of the FSP programmed in the FSP-OP mode register.

**Figure 98 - Entering Command Bus Training Mode and CA Training Pattern Input and Output with VREFCA Value Update**

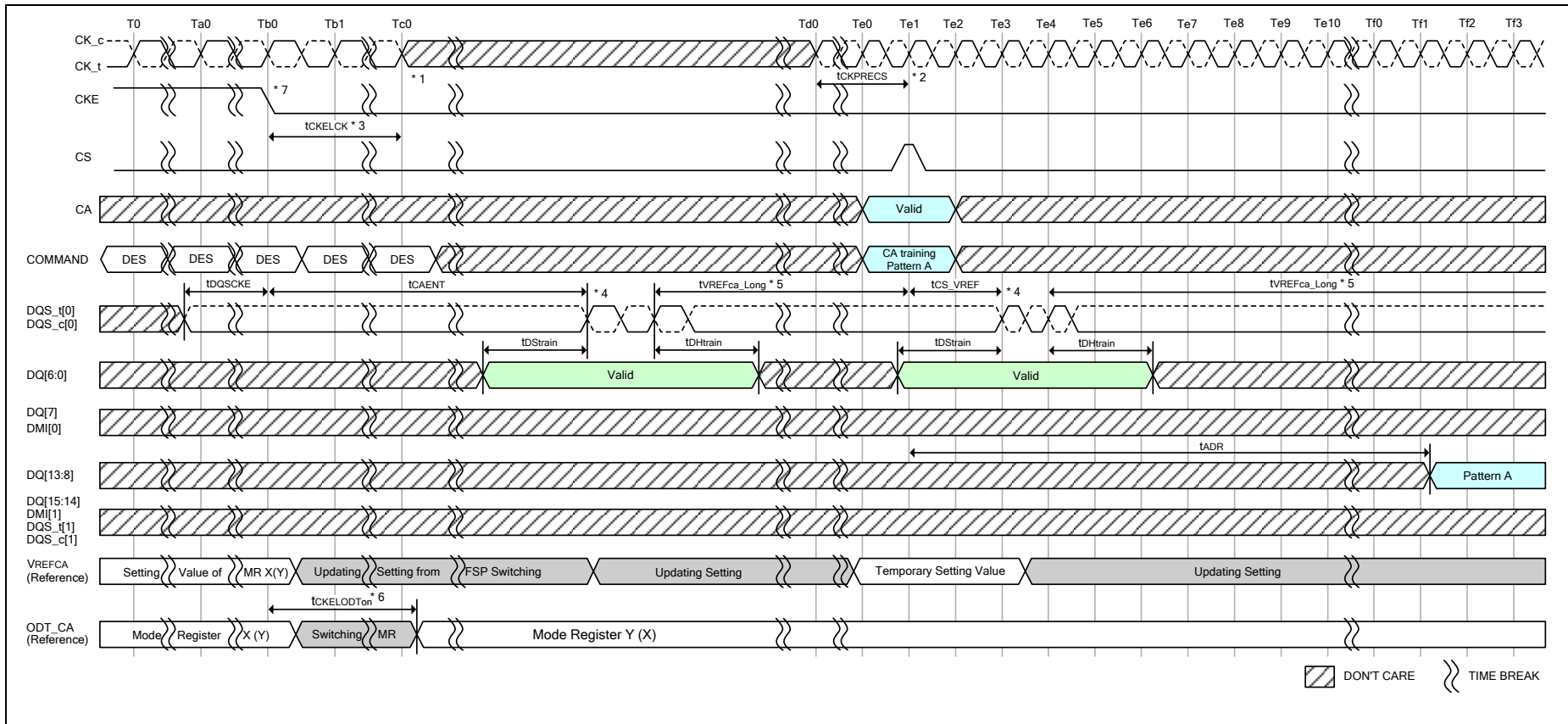

**Notes:**

1. After tCKELCK clock can be stopped or frequency changed any time.
2. The input clock condition should be satisfied tCKPRECIS.
3. Continue to Drive CK and Hold CS pins low until tCKELCK after CKE is low (which disables command decoding).
4. DRAM may or may not capture first rising/falling edge of DQS\_t/c due to an unstable first rising edge. Hence provide at least consecutive 2 pulses of DQS signal input is required in every DQS input signal at capturing DQ[6:0] signals. The captured value of DQ[6:0] signal level by each DQS edges are overwritten at any time and the DRAM updates its VREFCA setting of MR12 temporary after time tVREFca\_Long.
5. tVREF\_LONG may be reduced to tVREF\_SHORT if the following conditions are met: 1) The new VREF setting is a single step above or below the old VREF setting, and 2) The DQS pulses a single time, or the new VREF setting value on DQ[6:0] is static and meets tDStrain/tDHtrain for every DQS pulse applied.
6. When CKE is driven LOW, the SDRAM will switch its FSP-OP registers to use the alternate (i.e. non-active) set. Example: If the SDRAM is currently using FSP-OP[0], then it will switch to FSP-OP[1] when CKE is driven LOW. All operating parameters should be written to the alternate mode registers before entering Command Bus Training to ensure that ODT settings, RL/WL/nWR setting, etc., are set to the correct values. If the alternate FSP-OP has ODT\_CA disabled then termination will not enable in CA Bus Training mode. If the ODT\_CA pad is bonded to VSS, ODT\_CA termination will never enable for that die.
7. When CKE is driven low in Command Bus Training mode, the LPDDR4X SDRAM will change operation to the alternate FSP, i.e. the inverse of the FSP programmed in the FSP-OP mode register.

**Figure 99 - Consecutive VREFCA Value Update**

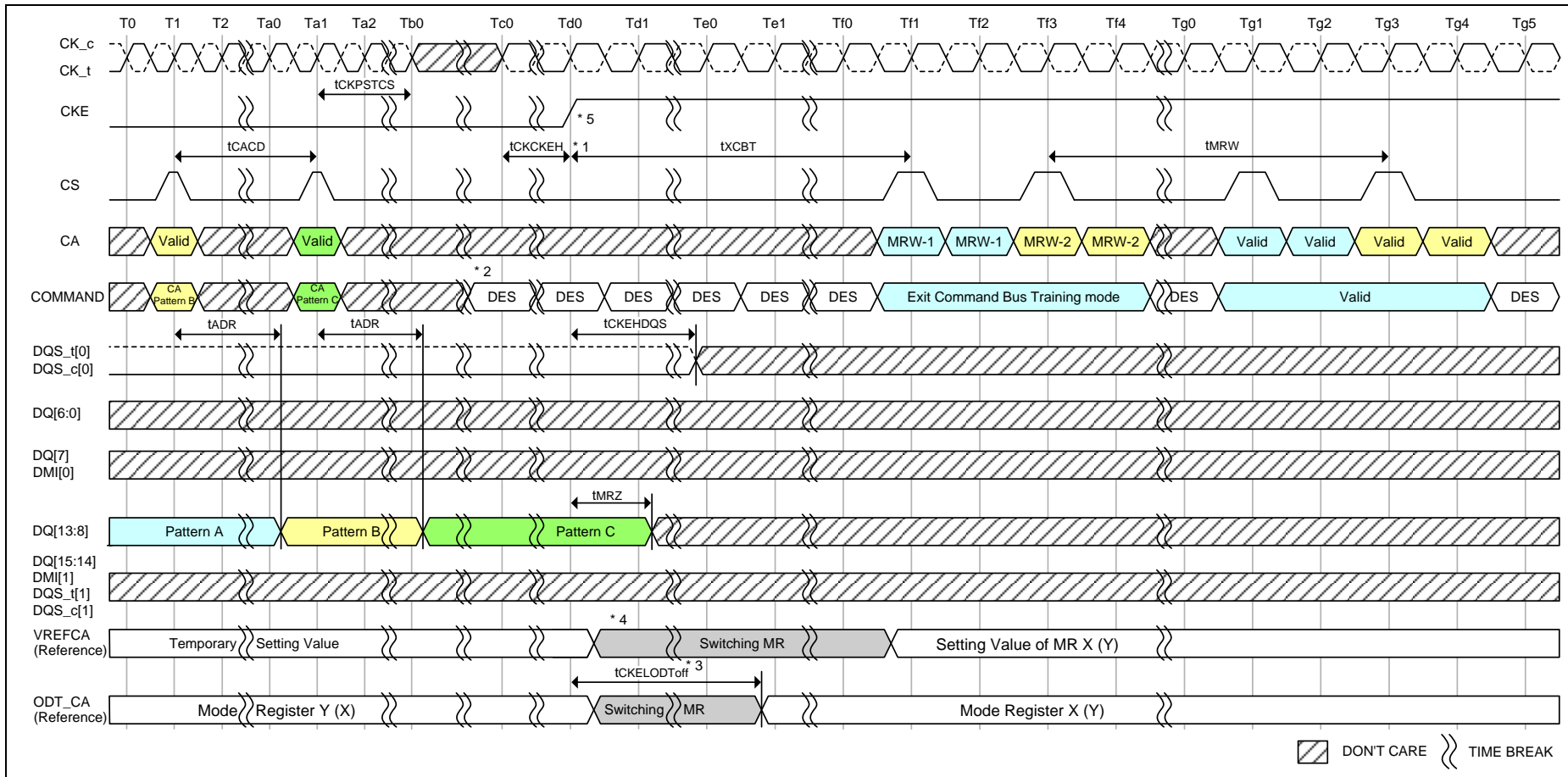

**Notes:**

1. Clock can be stopped or frequency changed any time before tCKCKEH. CK must meet tCKCKEH before CKE is driven high.  
When CKE is driven high the clock frequency must be returned to the original frequency (the frequency corresponding to the FSP at which Command Bus Training mode was entered)
2. CS must be Deselect (low) tCKCKEH before CKE is driven high.
3. When CKE is driven high, the SDRAM's ODT\_CA will revert to the state/value defined by FSP-OP prior to Command Bus Training mode entry, i.e. the original frequency set point (FSP-OP, MR13-OP[7]).  
Example: If the SDRAM was using FSP-OP[1] for training, then it will switch to FSP-OP[0] when CKE is driven HIGH.
4. Training values are not retained by the SDRAM, and must be written to the FSP-OP register set before returning to operation at the trained frequency.  
Example: VREF(CA) will return to the value programmed in the original set point.
5. When CKE is driven high the LPDDR4X SDRAM will revert to the FSP in operation when Command Bus Training mode was entered.

**Figure 100 - Exiting Command Bus Training Mode with Valid Command**

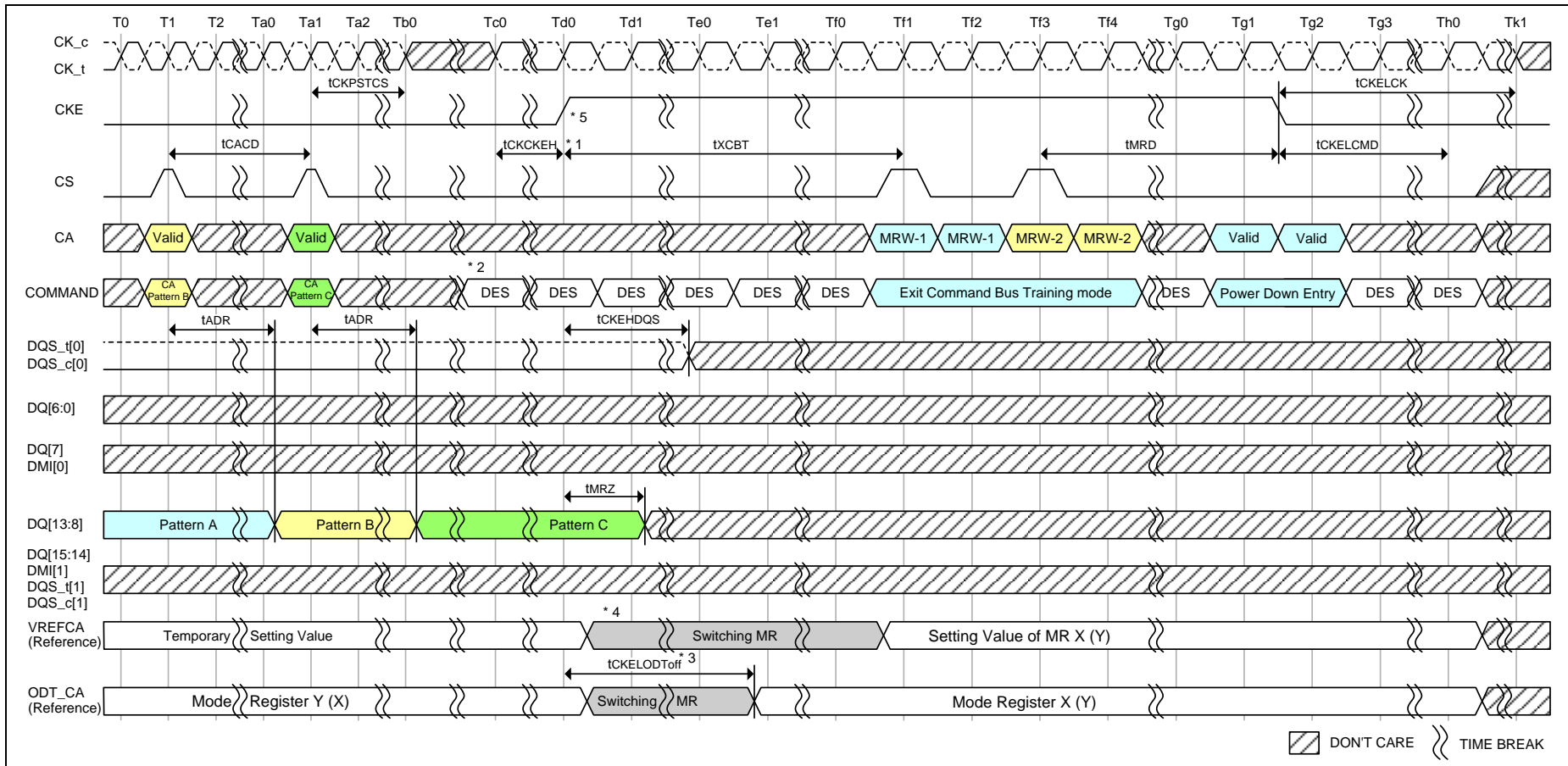

**Notes:**

1. Clock can be stopped or frequency changed any time before tCKCKEH. CK must meet tCKCKEH before CKE is driven high.  
When CKE is driven high the clock frequency must be returned to the original frequency (the frequency corresponding to the FSP at which Command Bus Training mode was entered)
2. CS must be Deselect (low) tCKCKEH before CKE is driven high.
3. When CKE is driven high, the SDRAM's ODT\_CA will revert to the state/value defined by FSP-OP prior to Command Bus Training mode entry, i.e. the original frequency set point (FSP-OP, MR13-OP[7]).  
Example: If the SDRAM was using FSP-OP[1] for training, then it will switch to FSP-OP[0] when CKE is driven HIGH.
4. Training values are not retained by the SDRAM, and must be written to the FSP-OP register set before returning to operation at the trained frequency.  
Example: VREF(CA) will return to the value programmed in the original set point.
5. When CKE is driven high the LPDDR4X SDRAM will revert to the FSP in operation when Command Bus Training mode was entered.

**Figure 101 - Exiting Command Bus Training Mode with Power Down Entry**



## 7.4.28.5 Command Bus Training AC Timing Table

Table 53 - Command Bus Training AC Timing

Parameter	Symbol	Min/ Max	Data Rate							Unit	Notes
			533	1066	1600	2133	2667	3200	3733		
<b>Command Bus Training Timing</b>											
Valid Clock Requirement after CKE Input low	tCKELCK	Min	Max(5nS, 5nCK)							-	
Data Setup for VREF Training Mode	tDStrain	Min	2							nS	
Data Hold for VREF Training Mode	tDHtrain	Min	2							nS	
Asynchronous Data Read	tADR	Max	20							nS	
CA Bus Training Command to CA Bus Training Command Delay	tCACD	Min	RU(tADR/tCK)							tCK	2
Valid Strobe Requirement before CKE Low	tDQSCKE	Min	10							nS	1
First CA Bus Training Command Following CKE Low	tCAENT	Min	250							nS	
VREF Step Time – multiple steps	tVREFCA_LONG	Max	250							nS	
VREF Step Time – one step	tVREFCA_SHORT	Max	80							nS	
Valid Clock Requirement before CS High	tCKPRECS	Min	2tCK + tXP (tXP = Max(7.5nS, 5nCK))							-	
Valid Clock Requirement after CS High	tCKPSTCS	Min	Max(7.5nS, 5nCK)							-	
Minimum delay from CS to DQS toggle in command bus training	tCS_VREF	Min	2							tCK	
Minimum delay from CKE High to Strobe High Impedance	tCKEHDQS		10							nS	
Valid Clock Requirement before CKE Input High	tCKCKEH	Min	Max(1.75nS, 3nCK)							-	
CA Bus Training CKE High to DQ Tri-state	tMRZ	Min	1.5							nS	
ODT turn-on Latency from CKE	tCKELODTon	Min	20							nS	
ODT turn-off Latency from CKE	tCKELODToff	Min	20							nS	
Exit Command Bus Training Mode to next valid command delay	tXCBT_Short	Min	Max(5nCK, 200nS)							-	3
	tXCBT_Middle	Min	Max(5nCK, 200nS)							-	3
	tXCBT_Long	Min	Max(5nCK, 250nS)							-	3

**Notes:**

- DQS\_t has to retain a low level during tDQSCKE period, as well as DQS\_c has to retain a high level.
- If tCACD is violated, the data for samples which violate tCACD will not be available, except for the last sample (where tCACD after this sample is met). Valid data for the last sample will be available after tADR.
- Exit Command Bus Training Mode to next valid command delay Time depends on value of VREF(CA) setting: MR12 OP[5:0] and VREF(CA) Range: MR12 OP[6] of FSP-OP 0 and 1. The details are shown in Table 57. Additionally exit Command Bus Training Mode to next valid command delay Time may affect VREF(DQ) setting. Settling time of VREF(DQ) level is same as VREF(CA) level.



### 7.4.29 Frequency Set Point

Frequency Set-Points allow the LPDDR4X-SDRAM CA Bus to be switched between two differing operating frequencies, with changes in voltage swings and termination values, without ever being in an untrained state which could result in a loss of communication to the DRAM. This is accomplished by duplicating all CA Bus mode register parameters, as well as other mode register parameters commonly changed with operating frequency. These duplicated registers form two sets that use the same mode register addresses, with read/write access controlled by MR bit FSP-WR (Frequency Set-Point Write/Read) and the DRAM operating point controlled by another MR bit FSP-OP (Frequency Set-Point Operation). Changing the FSPWR bit allows MR parameters to be changed for an alternate Frequency Set-Point without affecting the LPDDR4X-SDRAM's current operation. Once all necessary parameters have been written to the alternate Set-Point, changing the FSP-OP bit will switch operation to use all of the new parameters simultaneously (within tFC), eliminating the possibility of a loss of communication that could be caused by a partial configuration change.

Parameters which have two physical registers controlled by FSP-WR and FSP-OP are shown in the following table.

**Table 54 - Mode Register Function with two physical registers**

MR#	Operand	Function	Note
MR1	OP[2]	WR-PRE (WR Pre-amble Length)	
	OP[3]	RD-PRE (RD Pre-amble Type)	
	OP[6:4]	nWR (Write-Recovery for Auto-Precharge commands)	
	OP[7]	PST (RD Post-Ambles Length)	
MR2	OP[2:0]	RL (Read latency)	
	OP[5:3]	WL (Write latency)	
	OP[6]	WLS (Write Latency Set)	
MR3	OP[0]	PU-Cal (Pull-up Calibration Point)	1
	OP[1]	WR PST(WR Post-Ambles Length)	
	OP[5:3]	PDDS (Pull-Down Drive Strength)	
	OP[6]	DBI-RD (DBI-Read Enable)	
	OP[7]	DBI-WR (DBI-Write Enable)	
MR11	OP[2:0]	DQ ODT (DQ Bus Receiver On-Die-Termination)	
	OP[6:4]	CA ODT (CA Bus Receiver On-Die-Termination)	
MR12	OP[5:0]	VREF(ca) (VREF(ca) Setting)	
	OP[6]	VR-CA (VREF(ca) Range)	
MR14	OP[5:0]	VREF(dq) (VREF(dq) Setting)	
	OP[6]	VR(dq) (VREF(dq) Range)	
MR22	OP[2:0]	SoC ODT (Controller ODT Value for VOH calibration)	
	OP[3]	ODTE-CK (CK ODT enabled for non-terminating rank)	
	OP[4]	ODTE-CS (CS ODT enable for non-terminating rank)	
	OP[5]	ODTD-CA (CA ODT termination disable)	

**Note:**

1. For dual channel devices, PU-CAL setting is required as the same value for both Ch.A and Ch.B before issuing ZQ Cal start command.

See Mode Register Definition for more details.





Table 55 shows how the two mode registers for each of the parameters above can be modified by setting the appropriate FSP-WR value, and how device operation can be switched between operating points by setting the appropriate FSP-OP value. The FSP-WR and FSP-OP functions operate completely independently.

**Table 55 - Relation between MR Setting and DRAM Operation**

Function	MR# & Operand	Data	Operation	Notes
FSP-WR	MR13 OP[6]	0 (Default)	Data write to Mode Register N for FSP-OP[0] by MRW Command Data read from Mode Register N for FSP-OP[0] by MRR Command	1
		1	Data write to Mode Register N for FSP-OP[1] by MRW Command Data read from Mode Register N for FSP-OP[1] by MRR Command	
FSP-OP	MR13 OP[7]	0 (Default)	DRAM operates with Mode Register N for FSP-OP[0] setting	2
		1	DRAM operates with Mode Register N for FSP-OP[1] setting	

**Notes:**

1. FSP-WR stands for Frequency Set Point Write/Read.
2. FSP-OP stands for Frequency Set Point Operating Point.

**7.4.29.1 Frequency set point update Timing**

The Frequency set point update timing is shown in Figure 103. When changing the frequency set point via MR13 OP[7], the VRCG setting: MR13 OP[3] have to be changed into VREF Fast Response (high current) mode at the same time. After Frequency change time (tFC) is satisfied. VRCG can be changed into Normal Operation mode via MR13 OP[3].

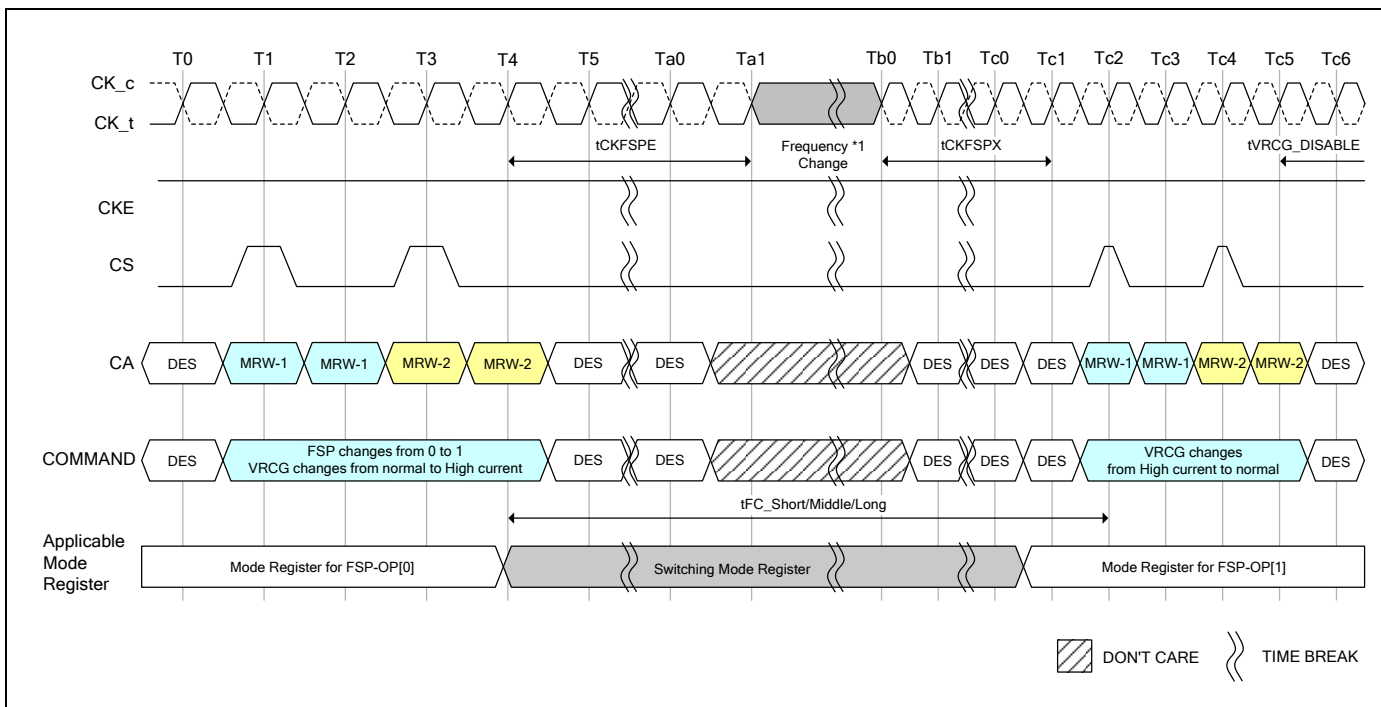

**Note:**

1. The definition that is Clock frequency change during CKE HIGH should be followed at the frequency change operation. For more information, refer to Section 7.4.45 Input Clock Stop and Frequency Change.

**Figure 102 - Frequency Set Point Switching Timing**



Table 56 - AC Timing Table

Parameter	Symbol	Min/ Max	Data Rate								Unit	Note
			533	1066	1600	2133	2667	3200	3733	4267		
Frequency Set Point parameters												
Frequency Set Point Switching Time	tFC_Short	Min	200								nS	1
	tFC_Middle	Min	200								nS	1
	tFC_Long	Min	250								nS	1
Valid Clock Requirement after Entering FSP Change	tCKFSPE	Min	max(7.5nS, 4nCK)								-	
Valid Clock Requirement before 1st Valid Command after FSP change	tCKFSPX	Min	max(7.5nS, 4nCK)								-	

**Note:**

1. Frequency Set Point Switching Time depends on value of VREF(CA) setting: MR12 OP[5:0] and VREF(CA) Range: MR12 OP[6] of FSP-OP 0 and 1. The details are shown in Table 57.

Additionally change of Frequency Set Point may affect VREF(DQ) setting. Settling time of VREF(DQ) level is same as VREF(CA) level.

Table 57 - tFC value mapping

Application	Step Size		Range	
	From FSP-OP0	To FSP-OP1	From FSP-OP0	To FSP-OP1
tFC_Short	Base	A single step size increment/decrement	Base	No Change
tFC_Middle	Base	Two or more step size increment/decrement	Base	No Change
tFC_Long	-	-	Base	Change

**Note:**

1. As well as change from FSP-OP1 to FSP-OP0.

Table 58 provides an example of tFC value mapping when FSP-OP moves from OP0 to OP1.

Table 58 - tFC value mapping example

Case	From/To	FSP-OP: MR13 OP[7]	VREF(CA) Setting: MR12 OP[5:0]	VREF(CA) Range: MR12 OP[6]	Application	Note
1	From	0	001100	0	tFC_Short	1
	To	1	001101	0		
2	From	0	001100	0	tFC_Middle	2
	To	1	001110	0		
3	From	0	Don't Care	0	tFC_Long	3
	To	1	Don't Care	1		

**Notes:**

1. A single step size increment/decrement for VREF(CA) Setting Value.
2. Two or more step size increment/decrement for VREF(CA) Setting Value.
3. VREF(CA) Range is changed. In this case changing VREF(CA) Setting doesn't affect tFC value.





The LPDDR4X-SDRAM defaults to FSP-OP[0] at power-up. Both Set-Points default to settings needed to operate in un-terminated, low-frequency environments. To enable the LPDDR4X-SDRAM to operate at higher frequencies, Command Bus Training mode should be utilized to train the alternate Frequency Set-Point (Figure 103). See the section Command Bus Training for more details on this training mode.

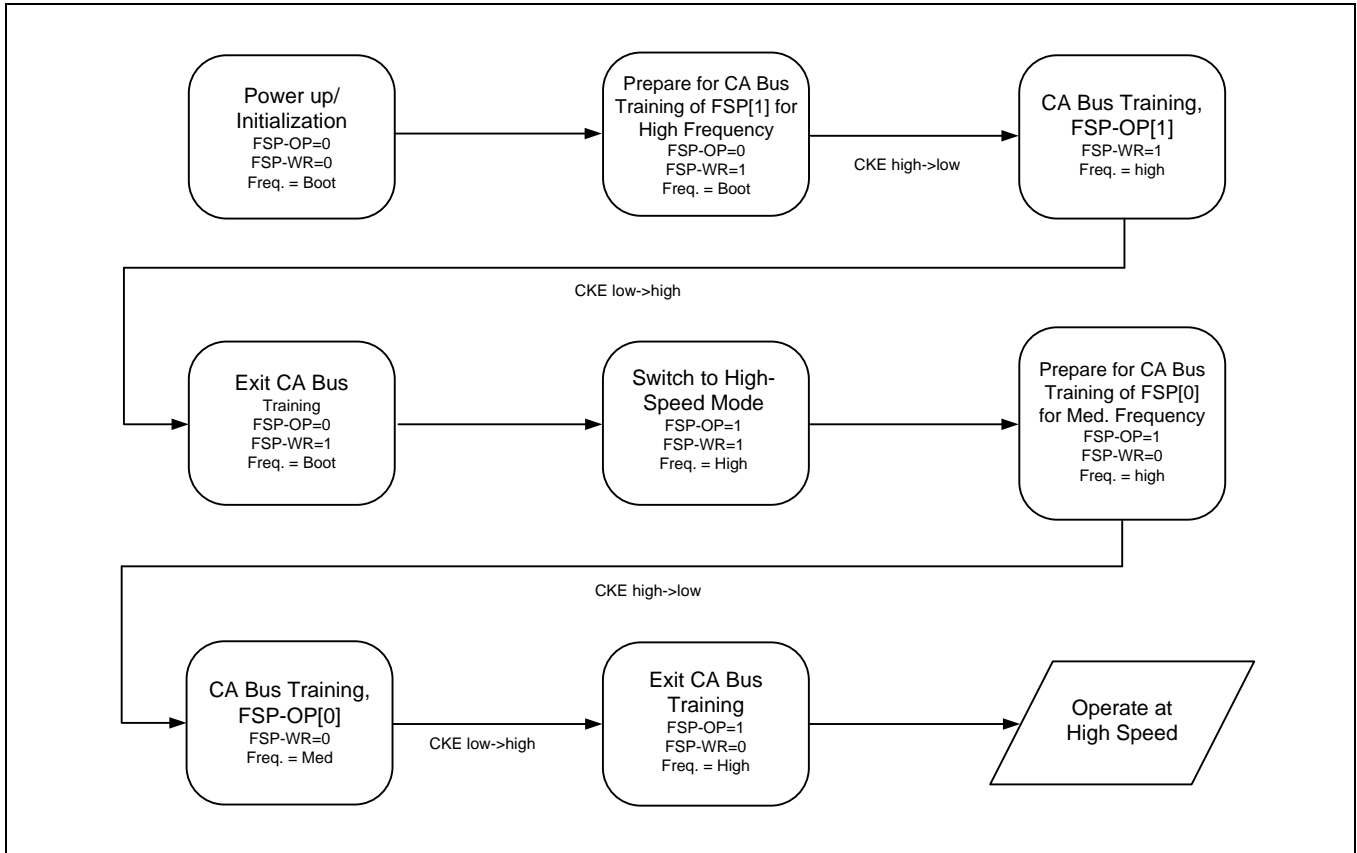

Figure 103 - Training Two Frequency Set-Points

Once both Frequency Set-Points have been trained, switching between points can be performed by a single MRW followed by waiting for tFC (Figure 104).

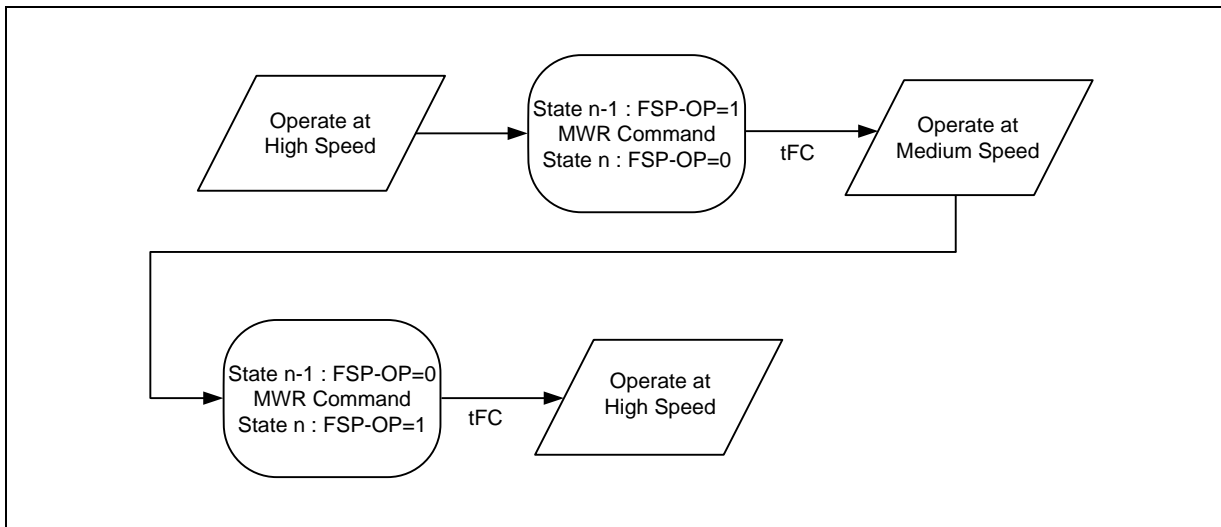

Figure 104 - Switching Between Two Trained Frequency Set-Points



Switching to a third (or more) Set-Point can be accomplished if the memory controller has stored the previously-trained values (in particular the VREF(CA) calibration value) and re-writes these to the alternate Set-Point before switching FSP-OP (Figure 105).

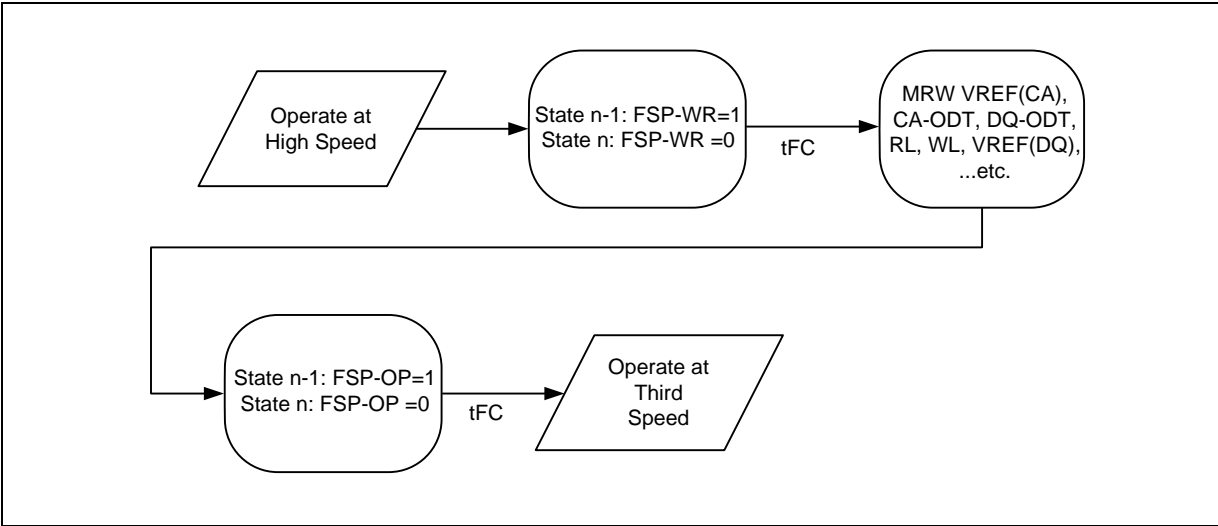

Figure 105 - Switching to a Third Trained Frequency Set-Point



### 7.4.30 Mode Register Write-WR Leveling Mode

To improve signal-integrity performance, the LPDDR4X SDRAM provides a write-leveling feature to compensate CK-to-DQS timing skew affecting timing parameters such as tDQSS, tDSS, and tDSH. The DRAM samples the clock state with the rising edge of DQS signals, and asynchronously feeds back to the memory controller. The memory controller references this feedback to adjust the clock-to-data strobe signal relationship for each DQS<sub>t</sub>/DQS<sub>c</sub> signal pair.

All data bits (DQ[7:0] for DQS<sub>t</sub>/DQS<sub>c</sub>[0], and DQ[15:8] for DQS<sub>t</sub>/DQS<sub>c</sub>[1]) carry the training feedback to the controller. Both DQS signals in each channel must be leveled independently. Write-leveling entry/exit is independent between channels for dual channel devices.

The LPDDR4X SDRAM enters into write-leveling mode when mode register MR2-OP[7] is set HIGH. When entering write-leveling mode, the state of the DQ pins is undefined. During write-leveling mode, only DESELECT commands are allowed, or a MRW command to exit the write-leveling operation. Depending on the absolute values of tDQSL and tDQSH in the application, the value of tDQSS may have to be better than the limits provided in the Write AC Timing Table<sup>1</sup> in order to satisfy the tDSS and tDSH specifications.

Upon completion of the write-leveling operation, the DRAM exits from write-leveling mode when MR2- OP[7] is reset LOW.

Write Leveling should be performed before Write Training (DQS2DQ Training).

#### 7.4.30.1 Write Leveling Procedure

1. Enter into Write-leveling mode by setting MR2-OP[7]=1.
2. Once entered into Write-leveling mode, DQS<sub>t</sub> must be driven LOW and DQS<sub>c</sub> HIGH after a delay of tWLDQSEN.
3. Wait for a time tWLMRD before providing the first DQS signal input. The delay time tWLMRD(MAX) is controller dependent.
4. DRAM may or may not capture first rising edge of DQS<sub>t</sub> due to an unstable first rising edge. Hence provide at least consecutive 2 pulses of DQS signal input is required in every DQS input signal during Write Training Mode. The captured clock level by each DQS edges are overwritten at any time and the DRAM provides asynchronous feedback on all the DQ bits after time tWLO.
5. The feedback provided by the DRAM is referenced by the controller to increment or decrement the DQS<sub>t</sub> and/or DQS<sub>c</sub> delay settings.
6. Repeat step 4 through step 5 until the proper DQS<sub>t</sub>/DQS<sub>c</sub> delay is established.
7. Exit from Write-leveling mode by setting MR2-OP[7]=0.



A Write Leveling timing example is shown in Figure 106, and Figure 107.

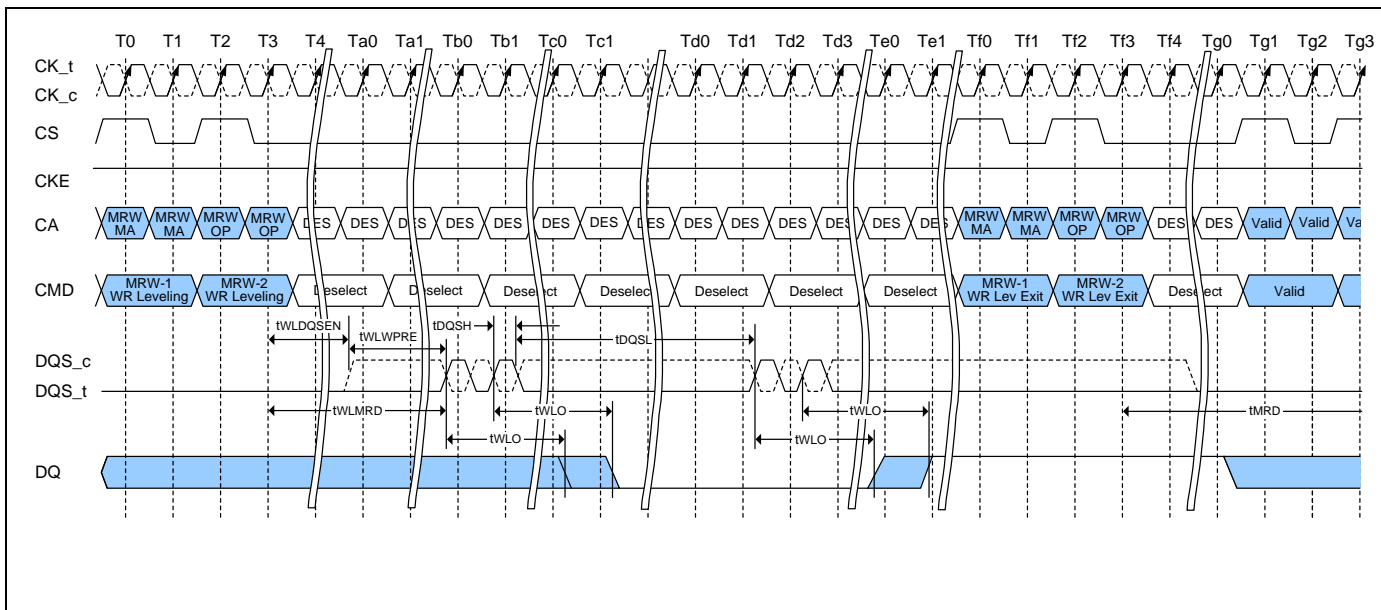

Figure 106 - Write Leveling Timing, tDQSL(max)

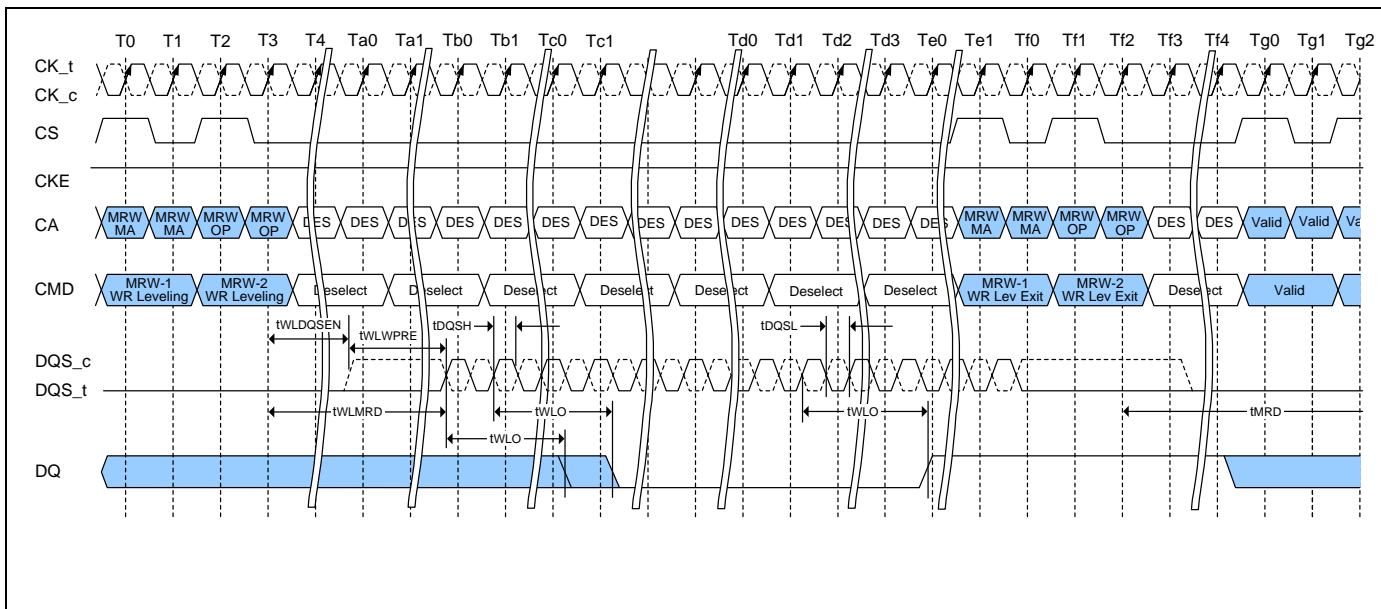

Figure 107 - Write Leveling Timing, tDQSL(min)



**7.4.30.2 Input Clock Frequency Stop and Change**

The input clock frequency can be stopped or changed from one stable clock rate to another stable clock rate during Write Leveling mode.

The Frequency stop or change timing is shown in Figure 108.

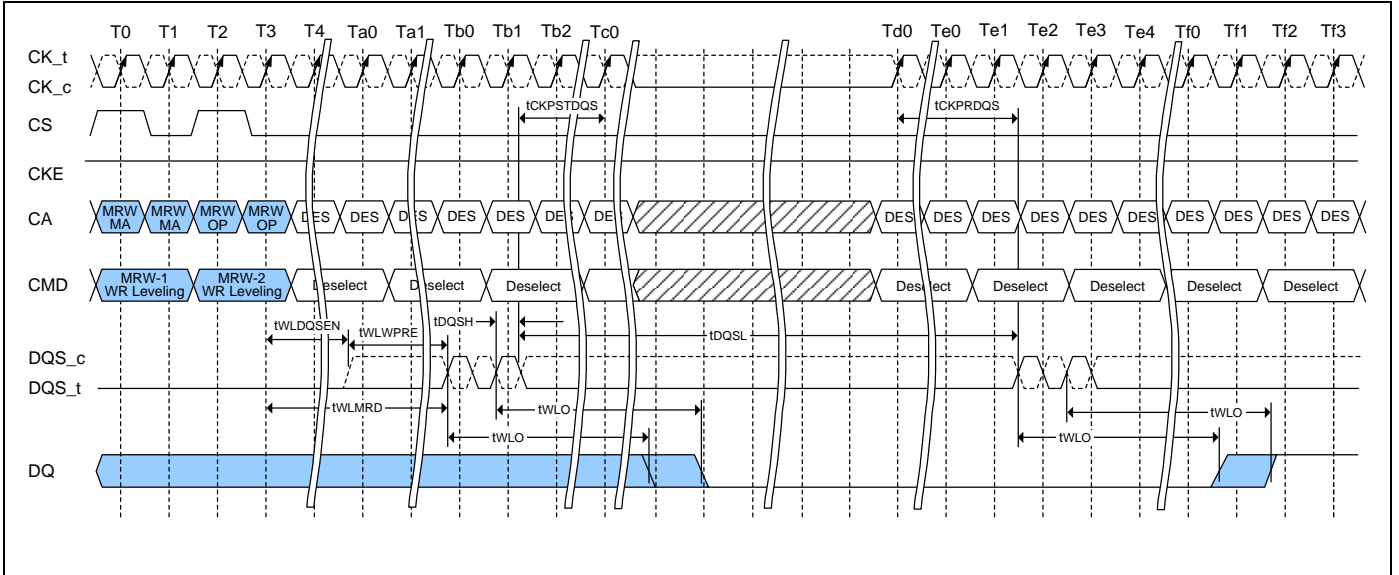

**Notes:**

1. CK\_t is held LOW and CK\_c is held HIGH during clock stop.
2. CS shall be held LOW during clock stop.

**Figure 108 - Clock Stop and Timing during Write Leveling**

**Table 59 - Write Leveling Timing Parameters**

Parameter	Symbol	Min/Max	Value	Units	Notes
DQS_t/DQS_c delay after write leveling mode is programmed	tWLDQSEN	Min	20	tCK	
		Max	-		
Write preamble for Write Leveling	tWLPRE	Min	20	tCK	
		Max	-		
First DQS_t/DQS_c edge after write leveling mode is programmed	tWLMRD	Min	40	tCK	
		Max	-		
Write leveling output delay	tWLO	Min	0	nS	
		Max	20		
Mode register set command delay	tMRD	Min	max(14nS, 10nCK)	nS	
		Max	-		
Valid Clock Requirement before DQS Toggle	tCKPRDQS	Min	max(7.5nS, 4nCK)	-	
		Max	-		
Valid Clock Requirement after DQS Toggle	tCKPSTDQS	Min	max(7.5nS, 4nCK)	-	
		Max	-		



7.4.30.3 Write Leveling Setup and Hold Time

Table 60 - Write Leveling Setup and Hold Time

Parameter	Symbol	Min/Max	Data Rate					Unit
			1600	2400	3200	3733	4267	
Write Leveling Parameters								
Write leveling hold time	tWLH	Min	150	100	75	62.5	50	pS
Write leveling setup time	tWLS	Min	150	100	75	62.5	50	pS
Write leveling input valid window	tWLIVW	Min	240	160	120	105	90	pS

Notes:

1. In addition to the traditional setup and hold time specifications above, there is value in an input valid window based specification for write-leveling training. As the training is based on each device, worst case process skews for setup and hold do not make sense to close timing between CK and DQS.
2. tWLIVW is defined in a similar manner to tdlvW\_Total, except that here it is a DQS input valid window with respect to CK. This would need to account for all VT (voltage and temperature) drift terms between CK and DQS within the DRAM that affect the write-leveling input valid window.

The DQS input mask for timing with respect to CK is shown in Figure 109. The "total" mask (tWLIVW) defines the time the input signal must not encroach in order for the DQS input to be successfully captured by CK. The mask is a receiver property and it is not the valid data-eye.

DQS t/DQS\_c and CK t/CK\_c at DRAM Latch

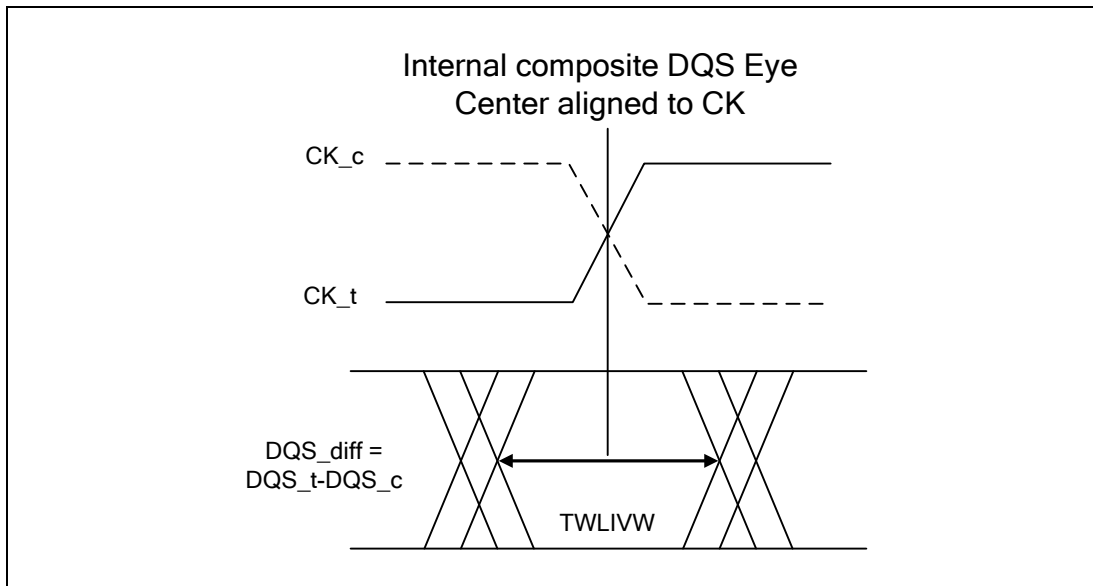

Figure 109 - DQS\_t/DQS\_c to CK\_t/CK\_c timings at the DRAM pins referenced from the internal latch



### 7.4.31 RD DQ Calibration

LPDDR4X devices feature a RD DQ Calibration training function that outputs a 16-bit user-defined pattern on the DQ pins. RD DQ Calibration is initiated by issuing a MPC-1 [RD DQ Calibration] command followed by a CAS-2 command, cause the LPDDR4X-SDRAM to drive the contents of MR32 followed by the contents of MR40 on each of DQ[15:0] and DMI[1:0]. The pattern can be inverted on selected DQ pins according to user-defined invert masks written to MR15 and MR20.

#### 7.4.31.1 RD DQ Calibration Training Procedure

The procedure for executing RD DQ Calibration is:

- Issue MRW commands to write MR32 (first eight bits), MR40 (second eight bits), MR15 (eight-bit invert mask for byte 0), and MR20 (eight-bit invert mask for byte 1).
- Optionally this step could be skipped to use the default patterns
  - MR32 default = 5A<sub>H</sub>
  - MR40 default = 3C<sub>H</sub>
  - MR15 default = 55<sub>H</sub>
  - MR20 default = 55<sub>H</sub>
- Issue an MPC-1 [RD DQ Calibration] command followed immediately by a CAS-2 command.
  - Each time an MPC-1 [RD DQ Calibration] command followed by a CAS-2 is received by the LPDDR4X SDRAM, a 16-bit data burst will, after the currently set RL, drive the eight bits programmed in MR32 followed by the eight bits programmed in MR40 on all I/O pins.
  - The data pattern will be inverted for I/O pins with a '1' programmed in the corresponding invert mask mode register bit (see Table 61).
  - Note that the pattern is driven on the DMI pins, but no data bus inversion function is enabled, even if Read DBI is enabled in the DRAM mode register.
  - The MPC-1 [RD DQ Calibration] command can be issued every tCCD seamlessly, and tRTRRD delay is required between Array Read command and the MPC-1 [RD DQ Calibration] command as well the delay required between the MPC-1 [RD DQ Calibration] command and an array read.
  - The operands received with the CAS-2 command must be driven LOW.
- DQ Read Training can be performed with any or no banks active, during Refresh, or during SREF with CKE high.

**Table 61 - Invert Mask Assignments**

DQ Pin	0	1	2	3	DMI0	4	5	6	7
MR15 bit	0	1	2	3	N/A	4	5	6	7

DQ Pin	8	9	10	11	DMI1	12	13	14	15
MR20 bit	0	1	2	3	N/A	4	5	6	7

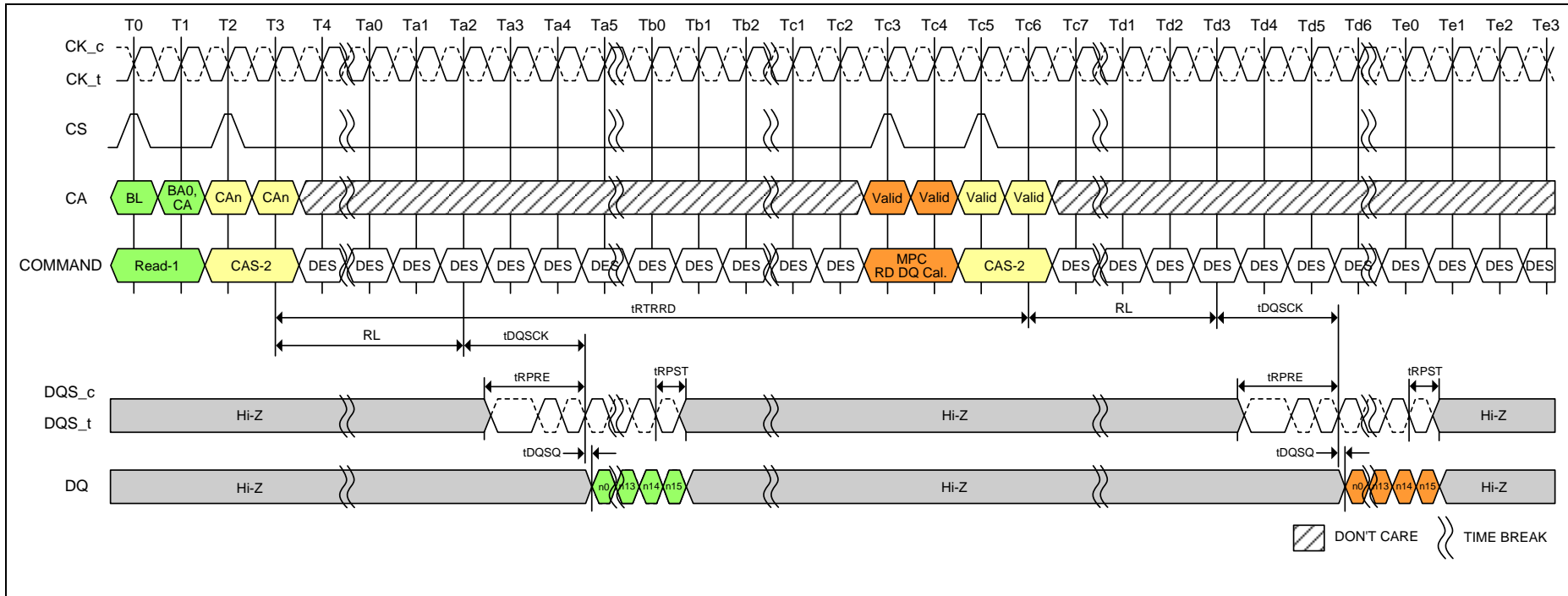

**Notes:**

1. Read-1 to MPC [RD DQ Calibration] Operation is shown as an example of command-to-command timing.  
Timing from Read-1 to MPC [RD DQ Calibration] command is tRTRRD.
2. MPC [RD DQ Calibration] uses the same command-to-data timing relationship (RL, tDQSK, tDQSQ) as a Read-1 command.
3. BL = 16, Read Preamble: Toggle, Read Postamble: 0.5nCK.
4. DES commands are shown for ease of illustration; other commands may be valid at these times.

**Figure 110 - DQ Read Training Timing: Read to Read DQ Calibration**



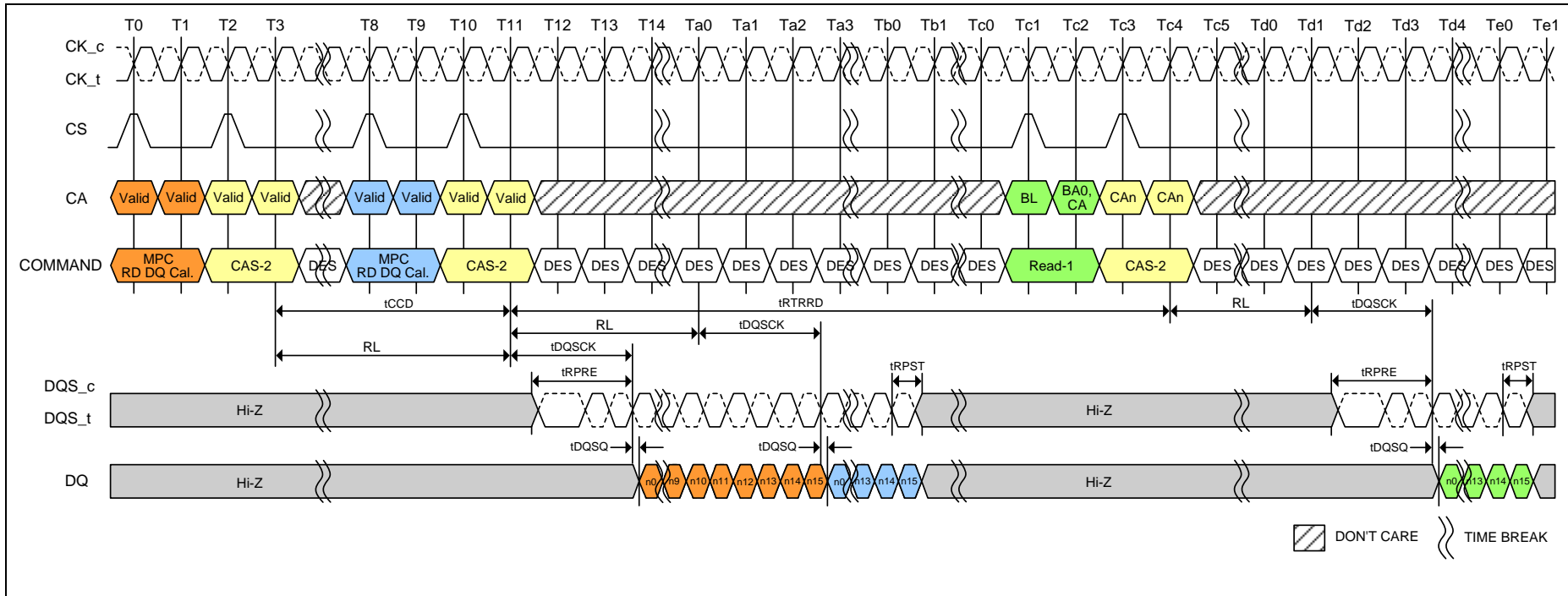

**Notes:**

1. MPC [RD DQ Calibration] to MPC [RD DQ Calibration] Operation is shown as an example of command-to-command timing.
2. MPC [RD DQ Calibration] to Read-1 Operation is shown as an example of command-to-command timing.
3. MPC [RD DQ Calibration] uses the same command-to-data timing relationship (RL, tDQSCK, tDQSQ) as a Read-1 command.
4. Seamless MPC [RD DQ Calibration] commands may be executed by repeating the command every tCCD time.
5. Timing from MPC [RD DQ Calibration] command to Read-1 is tRTRRD.
6. BL = 16, Read Preamble: Toggle, Read Postamble: 0.5nCK.
7. DES commands are shown for ease of illustration; other commands may be valid at these times.

**Figure 111 - DQ Read Training Timing: Read DQ Cal. to Read DQ Cal. / Read**



### 7.4.31.2 DQ Read Training Example

An example of DQ Read Training output is shown in Table 62. This shows the 16-bit data pattern that will be driven on each DQ in byte 0 when one DQ Read Training command is executed. This output assumes the following mode register values are used:

- MR32 = 1CH
- MR40 = 59H
- MR15 = 55H
- MR20 = 55H

**Table 62 - DQ Read Calibration Bit Ordering and Inversion Example**

Pin	Invert	Bit Sequence →															
		15	14	13	12	11	10	9	8	7	6	5	4	3	2	1	0
DQ0	Yes	1	0	1	0	0	1	1	0	1	1	1	0	0	0	1	1
DQ1	No	0	1	0	1	1	0	0	1	0	0	0	1	1	1	0	0
DQ2	Yes	1	0	1	0	0	1	1	0	1	1	1	0	0	0	1	1
DQ3	No	0	1	0	1	1	0	0	1	0	0	0	1	1	1	0	0
DMI0	Never	0	1	0	1	1	0	0	1	0	0	0	1	1	1	0	0
DQ4	Yes	1	0	1	0	0	1	1	0	1	1	1	0	0	0	1	1
DQ5	No	0	1	0	1	1	0	0	1	0	0	0	1	1	1	0	0
DQ6	Yes	1	0	1	0	0	1	1	0	1	1	1	0	0	0	1	1
DQ7	No	0	1	0	1	1	0	0	1	0	0	0	1	1	1	0	0
DQ8	Yes	1	0	1	0	0	1	1	0	1	1	1	0	0	0	1	1
DQ9	No	0	1	0	1	1	0	0	1	0	0	0	1	1	1	0	0
DQ10	Yes	1	0	1	0	0	1	1	0	1	1	1	0	0	0	1	1
DQ11	No	0	1	0	1	1	0	0	1	0	0	0	1	1	1	0	0
DMI1	Never	0	1	0	1	1	0	0	1	0	0	0	1	1	1	0	0
DQ12	Yes	1	0	1	0	0	1	1	0	1	1	1	0	0	0	1	1
DQ13	No	0	1	0	1	1	0	0	1	0	0	0	1	1	1	0	0
DQ14	Yes	1	0	1	0	0	1	1	0	1	1	1	0	0	0	1	1
DQ15	No	0	1	0	1	1	0	0	1	0	0	0	1	1	1	0	0

**Notes:**

- The patterns contained in MR32 and MR40 are transmitted on DQ[15:0] and DMI[1:0] when RD DQ Calibration is initiated via a MPC-1 [RD DQ Calibration] command. The pattern transmitted serially on each data lane, organized "little endian" such that the low-order bit in a byte is transmitted first. If the data pattern is 27H, then the first bit transmitted will be a '1', followed by '1', '1', '0', '0', '1', '0', and '0'. The bit stream will be 00100111 →.
- MR15 and MR20 may be used to invert the MR32/MR40 data pattern on the DQ pins. See MR15 and MR20 for more information. Data is never inverted on the DMI[1:0] pins.
- DMI [1:0] outputs status follows Table 63.



Table 63 - MR Setting vs. DMI Status

DM Function MR13 OP[5]	Write DBI dc Function MR3 OP[7]	Read DBI dc Function MR3 OP[6]	DMI Status
1: Disable	0: Disable	0: Disable	Hi-Z
1: Disable	1: Enable	0: Disable	The data pattern is transmitted
1: Disable	0: Disable	1: Enable	The data pattern is transmitted
1: Disable	1: Enable	1: Enable	The data pattern is transmitted
0: Enable	0: Disable	0: Disable	The data pattern is transmitted
0: Enable	1: Enable	0: Disable	The data pattern is transmitted
0: Enable	0: Disable	1: Enable	The data pattern is transmitted
0: Enable	1: Enable	1: Enable	The data pattern is transmitted

4. No Data Bus Inversion (DBI) function is enacted during RD DQ Calibration, even if DBI is enabled in MR3-OP[6].

**7.4.31.3 MPC of Read DQ Calibration after Power-Down Exit**

Following the power-down state, an additional time, tMRR1, is required prior to issuing the MPC of Read DQ Calibration command. This additional time (equivalent to tRCD) is required in order to be able to maximize power-down current savings by allowing more power-up time for the Read DQ data in MR32 and MR40 data path after exit from standby, power-down mode.

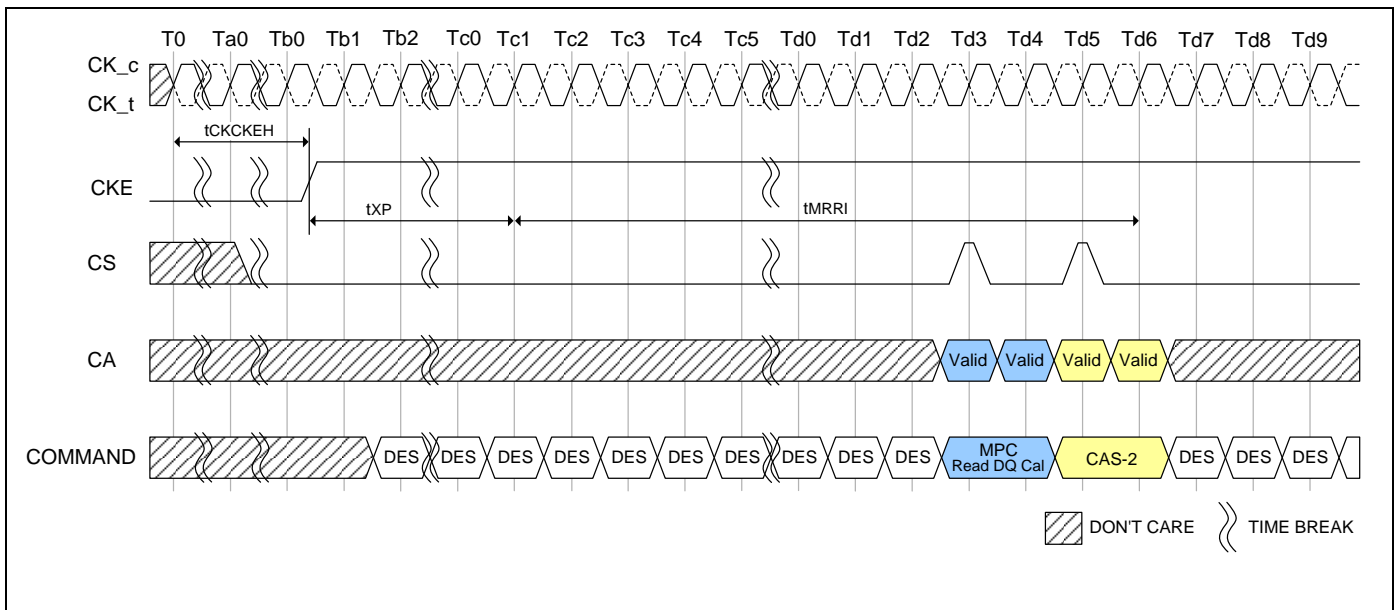

Figure 112 - MPC Read DQ Calibration Following Power-Down State



### 7.4.32 DQS-DQ Training

The LPDDR4X-SDRAM uses an un-matched DQS-DQ path to enable high speed performance and save power in the DRAM. As a result, the DQS strobe must be trained to arrive at the DQ latch center-aligned with the Data eye. The SDRAM DQ receiver is located at the DQ pad, and has a shorter internal delay in the SDRAM than does the DQS signal. The SDRAM DQ receiver will latch the data present on the DQ bus when DQS reaches the latch, and training is accomplished by delaying the DQ signals relative to DQS such that the Data eye arrives at the receiver latch centered on the DQS transition.

Two modes of training are available in LPDDR4X:

- Command-based FIFO WR/RD with user patterns
- An internal DQS clock-tree oscillator, to determine the need for, and the magnitude of required training.

The command-based FIFO WR/RD uses the MPC command with operands to enable this special mode of operation. When issuing the MPC command, if OP6 is set LOW then the DRAM will perform a NOP command. When OP6 is set HIGH, then OP5:0 enable training functions or are reserved for future use (RFU). MPC commands that initiate a Read FIFO, READ DQ Calibration or Write FIFO to the SDRAM must be followed immediately by a CAS-2 command. See "Multi-Purpose Command (MPC) Definition" for more information.

To perform Write Training, the controller can issue a MPC [Write DQ FIFO] command with OP[6:0] set as described in the MPC Definition section, followed immediately by a CAS-2 command (CAS-2 operands should be driven LOW) to initiate a Write DQ FIFO. Timings for MPC [Write DQ FIFO] are identical to a Write command, with WL (Write Latency) timed from the 2nd rising clock edge of the CAS-2 command. Up to 5 consecutive MPC [Write DQ FIFO] commands with user defined patterns may be issued to the SDRAM to store up to 80 values (BL16 x5) per pin that can be read back via the MPC [Read DQ FIFO] command. Write/Read FIFO Pointer operation is described later in this section.

After writing data to the SDRAM with the MPC [Write DQ FIFO] command, the data can be read back with the MPC [Read DQ FIFO] command and results compared with "expect" data to see if further training (DQ delay) is needed. MPC [Read DQ FIFO] is initiated by issuing a MPC command with OP[6:0] set as described in the MPC Definition section, followed immediately by a CAS-2 command (CAS-2 operands must be driven LOW). Timings for the MPC [Read DQ FIFO] command are identical to a Read command, with RL (Read Latency) timed from the 2nd rising clock edge of the CAS-2 command.

Read DQ FIFO is non-destructive to the data captured in the FIFO, so data may be read continuously until it is either overwritten by a Write DQ FIFO command or disturbed by CKE LOW or any of the following commands; Write, Masked Write, Read, Read DQ Calibration and a MRR. If fewer than 5 Write DQ FIFO commands were executed, then unwritten registers will have un-defined (but valid) data when read back.

For example: If 5 Write DQ FIFO commands are executed sequentially, then a series of Read DQ FIFO commands will read valid data from FIFO[0], FIFO[1]....FIFO[4], and will then wrap back to FIFO[0] on the next Read DQ FIFO.

On the other hand, if fewer than 5 Write DQ FIFO commands are executed sequentially (example=3), then a series of Read DQ FIFO commands will return valid data for FIFO[0], FIFO[1], and FIFO[2], but the next two Read DQ FIFO commands will return un-defined data for FIFO[3] and FIFO[4] before wrapping back to the valid data in FIFO[0].



#### 7.4.32.1 FIFO Pointer Reset and Synchronism

The Read and Write DQ FIFO pointers are reset under the following conditions:

- Power-up initialization
- RESET\_n asserted
- Power-down entry
- Self Refresh Power-Down entry

The MPC [Write DQ FIFO] command advances the WR-FIFO pointer, and the MPC [Read DQ FIFO] advances the RD-FIFO pointer. Also any normal (non-FIFO) Read Operation (RD, RDA) advances both WR-FIFO pointer and RD-FIFO pointer. Issuing (non-FIFO) Read Operation command is inhibited during Write training period. To keep the pointers aligned, the SoC memory controller must adhere to the following restriction at the end of Write training period:

- $b = a + (n \times c)$

Where:

'a' is the number of MPC [Write DQ FIFO] commands

'b' is the number of MPC [Read DQ FIFO] commands

'c' is the FIFO depth (=5 for LPDDR4X)

'n' is a positive integer,  $\geq 0$

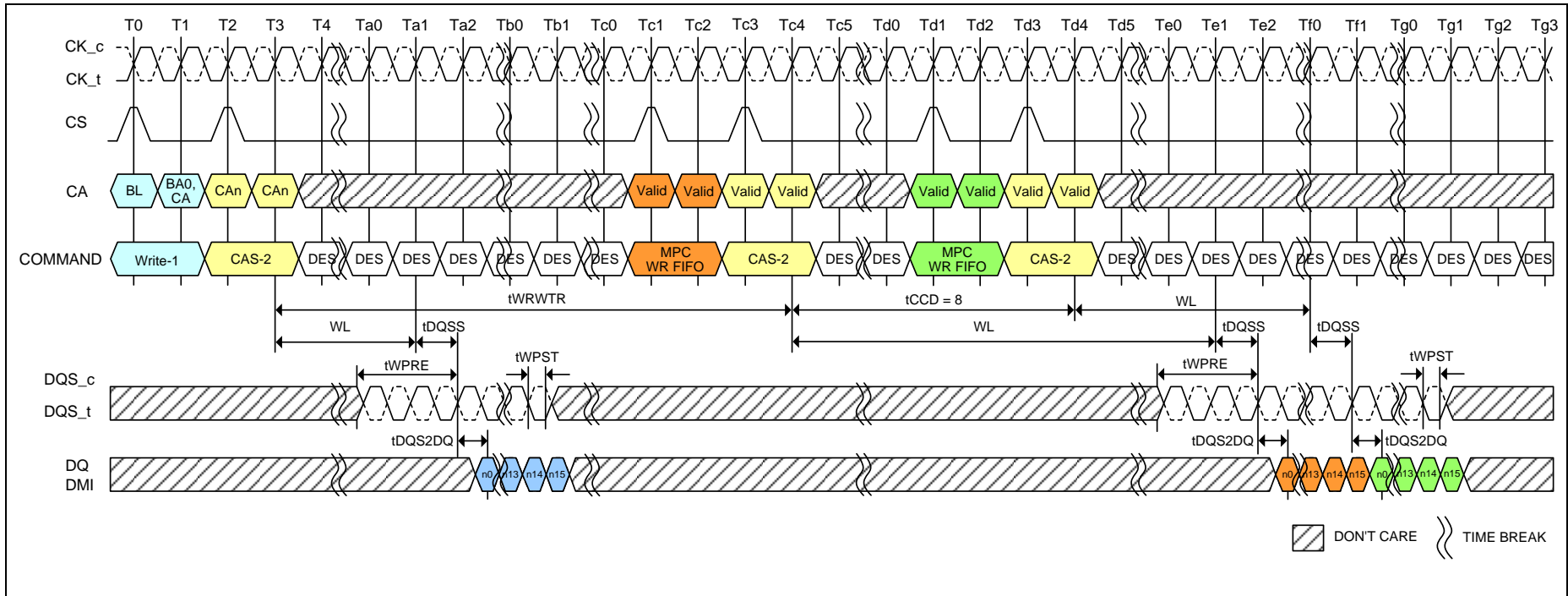

**Notes:**

1. MPC [WR FIFO] can be executed with a single bank or multiple banks active, during Refresh, or during SREF with CKE HIGH.
2. Write-1 to MPC is shown as an example of command-to-command timing for MPC. Timing from Write-1 to MPC [WR-FIFO] is tWRWTR.
3. Seamless MPC [WR-FIFO] commands may be executed by repeating the command every tCCD time.
4. MPC [WR-FIFO] uses the same command-to-data timing relationship (WL, tDQSS, tDQS2DQ) as a Write-1 command.
5. A maximum of 5 MPC [WR-FIFO] commands may be executed consecutively without corrupting FIFO data.  
The 6th MPC [WR-FIFO] command will overwrite the FIFO data from the first command. If fewer than 5 MPC [WR-FIFO] commands are executed, then the remaining FIFO locations will contain undefined data.
6. For the CAS-2 command following a MPC command, the CAS-2 operands must be driven "LOW".
7. To avoid corrupting the FIFO contents, MPC [RD-FIFO] must immediately follow MPC [WR-FIFO]/CAS-2 without any other command disturbing FIFO pointers in-between. FIFO pointers are disturbed by CKE Low, Write, Masked Write, Read, Read DQ Calibration and MRR.
8. BL = 16, Write Postamble = 0.5nCK.
9. DES commands are shown for ease of illustration; other commands may be valid at these times.

**Figure 113 - Write to MPC [Write FIFO] Operation Timing**

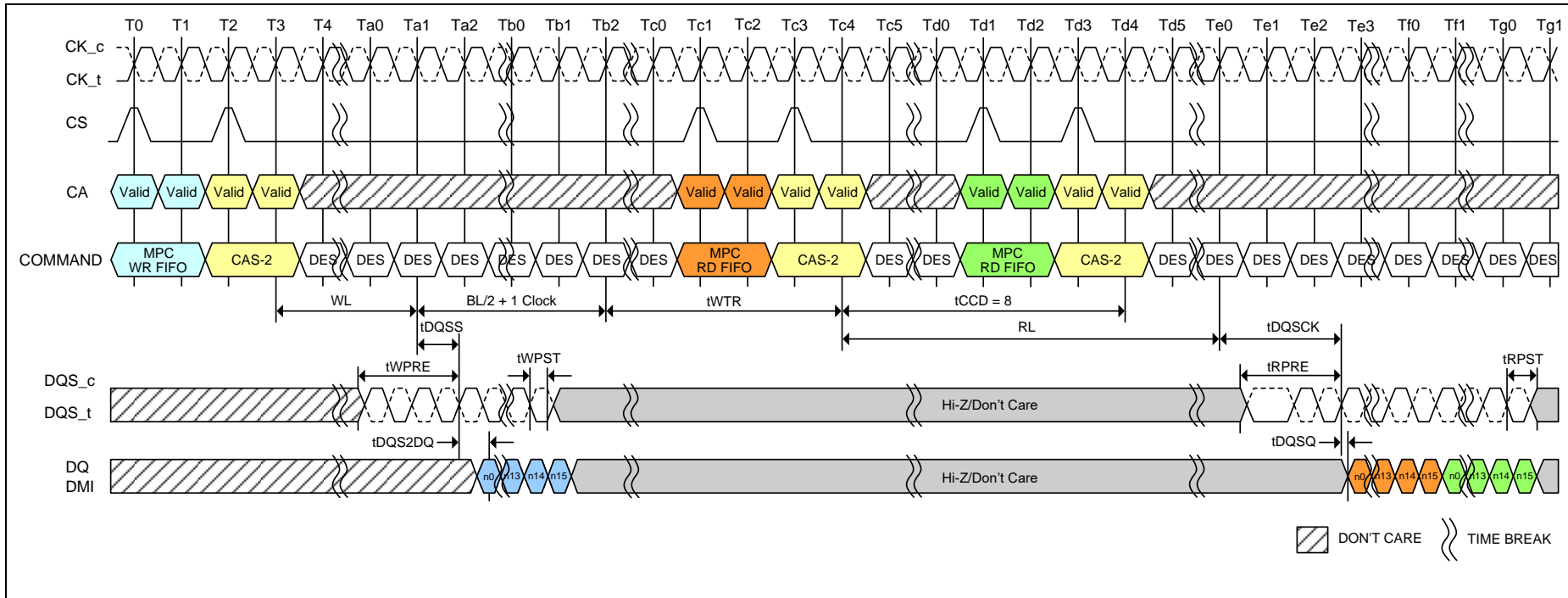

**Notes:**

1. MPC [WR FIFO] can be executed with a single bank or multiple banks active, during Refresh, or during SREF with CKE HIGH.
2. MPC [WR-FIFO] to MPC [RD-FIFO] is shown as an example of command-to-command timing for MPC. Timing from MPC [WR-FIFO] to MPC [RD-FIFO] is specified in the command-to-command timing table.
3. Seamless MPC [RD-FIFO] commands may be executed by repeating the command every tCCD time.
4. MPC [RD-FIFO] uses the same command-to-data timing relationship (RL, tDQSK, tDQSQ) as a Read-1 command.
5. Data may be continuously read from the FIFO without any data corruption. After 5 MPC [RD-FIFO] commands the FIFO pointer will wrap back to the 1st FIFO and continue advancing. If fewer than 5 MPC [WR-FIFO] commands were executed, then the MPC [RD-FIFO] commands to those FIFO locations will return undefined data. See the Write Training section for more information on the FIFO pointer behavior.
6. For the CAS-2 command immediately following a MPC command, the CAS-2 operands must be driven "LOW".
7. DMI[1:0] signals will be driven if any of WR-DBI, RD-DBI, or DM is enabled in the mode registers. See Write Training section for more information on DMI behavior.
8. BL = 16, Write Postamble = 0.5nCK, Read Preamble: Toggle, Read Postamble: 0.5nCK.
9. DES commands are shown for ease of illustration; other commands may be valid at these times.

**Figure 114 - MPC [Write FIFO] to MPC [Read FIFO] Timing**



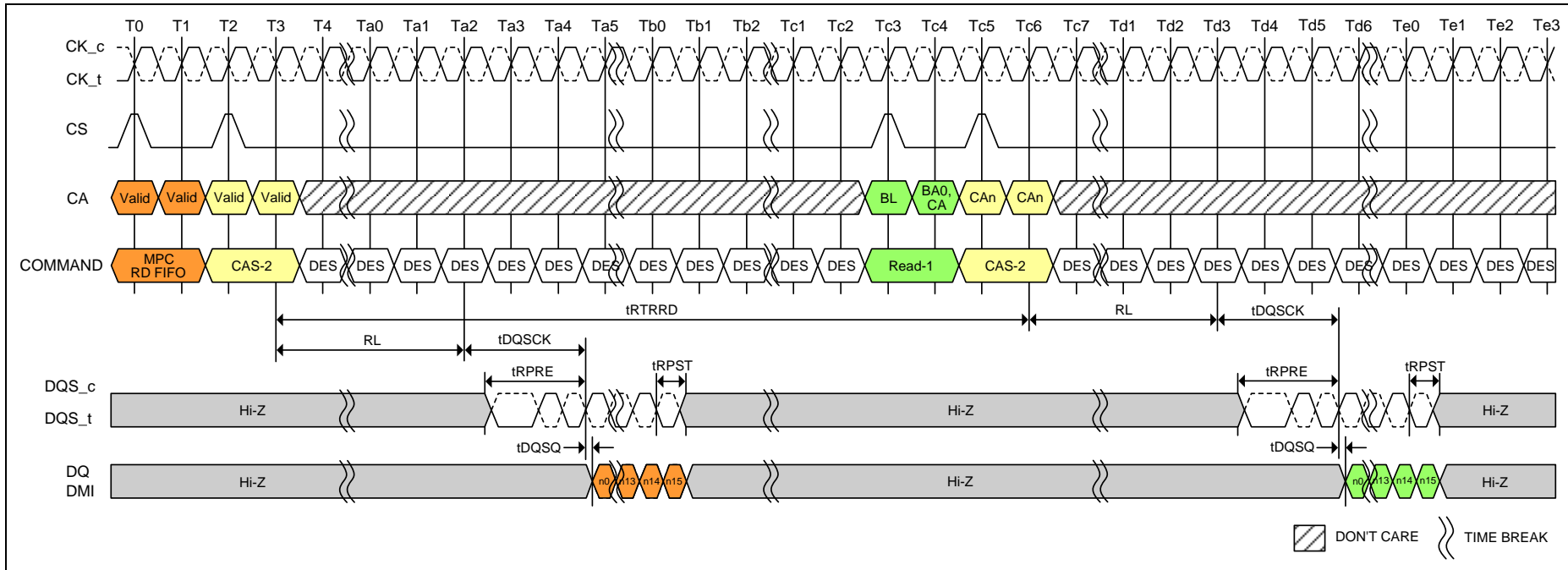

**Notes:**

1. MPC [WR FIFO] can be executed with a single bank or multiple banks active, during Refresh, or during SREF with CKE HIGH.
2. MPC [RD-FIFO] to Read-1 Operation is shown as an example of command-to-command timing for MPC. Timing from MPC [RD-FIFO] command to Read is tRTRRD.
3. Seamless MPC [RD-FIFO] commands may be executed by repeating the command every tCCD time.
4. MPC [RD-FIFO] uses the same command-to-data timing relationship (RL, tDQSK, tDQSQ) as a Read-1 command.
5. Data may be continuously read from the FIFO without any data corruption. After 5 MPC [RD-FIFO] commands the FIFO pointer will wrap back to the 1st FIFO and continue advancing. If fewer than 5 MPC [WR-FIFO] commands were executed, then the MPC [RD-FIFO] commands to those FIFO locations will return undefined data. See the Write Training section for more information on the FIFO pointer behavior.
6. For the CAS-2 command immediately following a MPC command, the CAS-2 operands must be driven "LOW".
7. DMI[1:0] signals will be driven if any of WR-DBI, RD-DBI, or DM is enabled in the mode registers. See Write Training section for more information on DMI behavior.
8. BL = 16, Read Preamble: Toggle, Read Postamble: 0.5nCK.
9. DES commands are shown for ease of illustration; other commands may be valid at these times.

**Figure 115 - MPC [Read FIFO] to Read Timing**



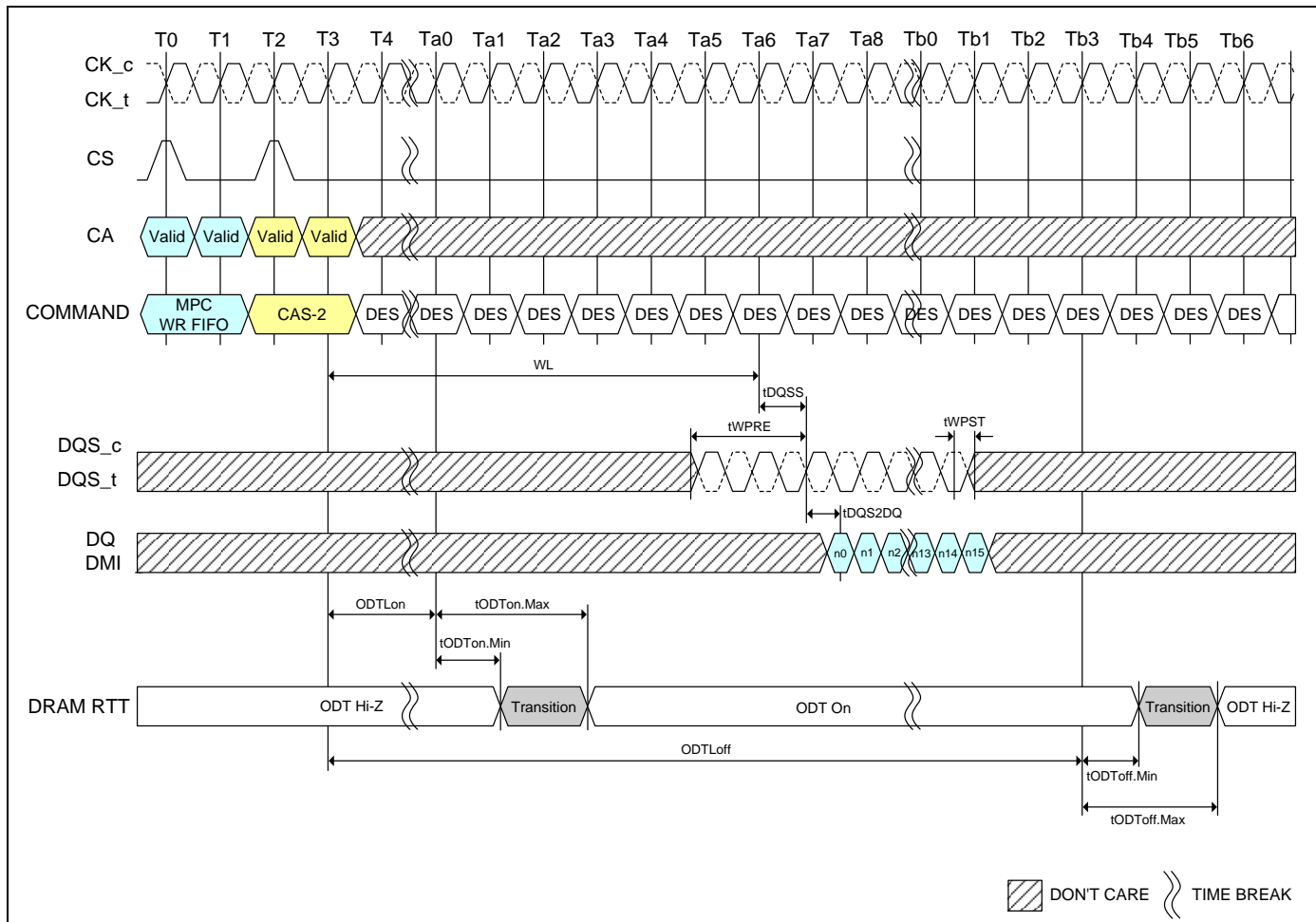

**Notes:**

1. MPC [WR FIFO] can be executed with a single bank or multiple banks active, during Refresh, or during SREF with CKE HIGH.
2. MPC [WR-FIFO] uses the same command-to-data/ODT timing relationship (WL, tDQSS, tDQS2DQ, ODTLon, ODTLoff, tODTon, tODToff) as a Write-1 command.
3. For the CAS-2 command immediately following a MPC command, the CAS-2 operands must be driven "LOW".
4. BL = 16, Write Postamble = 0.5nCK.
5. DES commands are shown for ease of illustration; other commands may be valid at these times.

**Figure 116 - MPC [Write FIFO] with DQ ODT Timing**

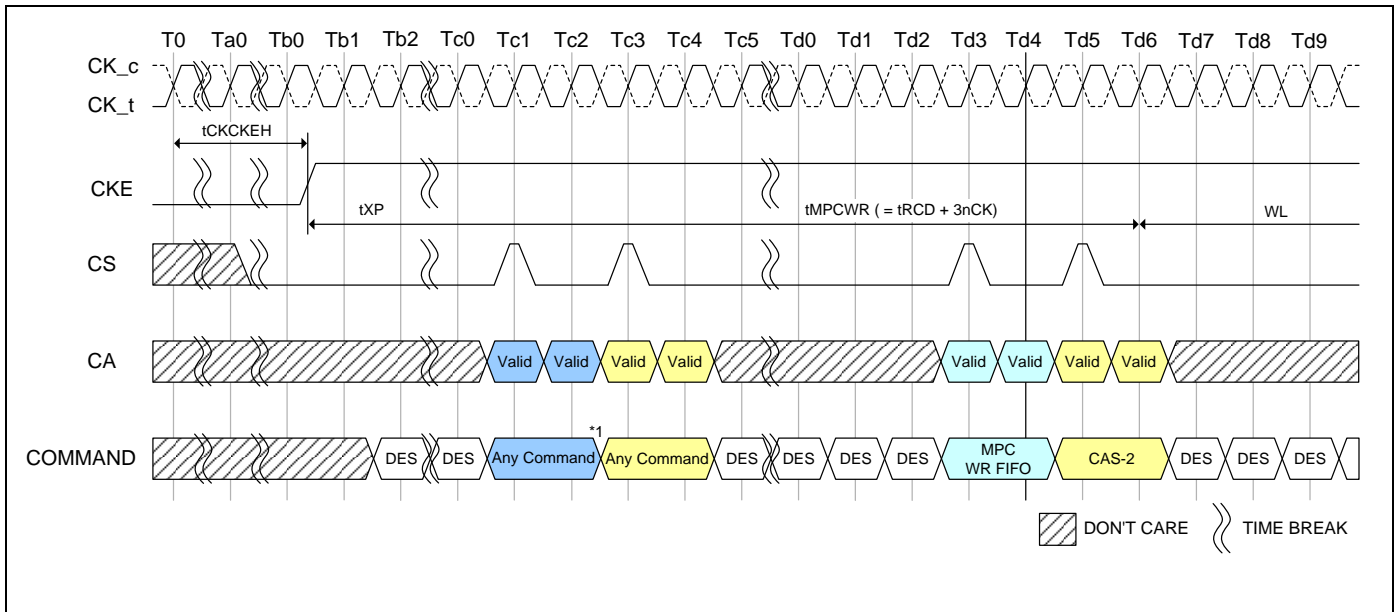

**Notes:**

1. Any commands except MPC WR FIFO and other exception commands defined other section in this document (i.e. MPC Read DQ Cal).
2. DES commands are shown for ease of illustration; other commands may be valid at these times.

**Figure 117 - Power Down Exit to MPC [Write FIFO] Timing**

**Table 64 - MPC [Write FIFO] AC Timing**

Parameter	Symbol	Min/Max	Data Rate	Unit	Note
MPC Write FIFO Timing					
Additional time after tXP has expired until MPC [Write FIFO] command may be issued	tMPCWR	Min	tRCD + 3nCK		

**7.4.33 DQS Interval Oscillator**

As voltage and temperature change on the SDRAM die, the DQS clock tree delay will shift and may require re-training. The LPDDR4X-SDRAM includes an internal DQS clock-tree oscillator to measure the amount of delay over a given time interval (determined by the controller), allowing the controller to compare the trained delay value to the delay value seen at a later time. The DQS Oscillator will provide the controller with important information regarding the need to re-train, and the magnitude of potential error.

The DQS Interval Oscillator is started by issuing a MPC [Start DQS Osc] command with OP[6:0] set as described in the MPC Operation section, which will start an internal ring oscillator that counts the number of time a signal propagates through a copy of the DQS clock tree.

The DQS Oscillator may be stopped by issuing a MPC [Stop DQS Osc] command with OP[6:0] set as described in the MPC Operation section, or the controller may instruct the SDRAM to count for a specific number of clocks and then stop automatically (See MR23 for more information). If MR23 is set to automatically stop the DQS Oscillator, then the MPC [Stop DQS Osc] command should not be used (illegal). When the DQS Oscillator is stopped by either method, the result of the oscillator counter is automatically stored in MR18 and MR19.



The controller may adjust the accuracy of the result by running the DQS Interval Oscillator for shorter (less accurate) or longer (more accurate) duration. The accuracy of the result for a given temperature and voltage is determined by the following equation:

$$\text{DQS Oscillator Granularity Error} = \frac{2 * (\text{DQS delay})}{\text{Run Time}}$$

Where:

Run Time = total time between start and stop commands

DQS delay = the value of the DQS clock tree delay (tDQS2DQ min/max)

Additional matching error must be included, which is the difference between DQS training circuit and the actual DQS clock tree across voltage and temperature. The matching error is vendor specific.

Therefore, the total accuracy of the DQS Oscillator counter is given by:

$$\text{DQS Oscillator Accuracy} = 1 - \text{Granularity Error} - \text{Matching Error}$$

**Example:** If the total time between start and stop commands is 100nS, and the maximum DQS clock tree delay is 800pS (tDQS2DQ max), then the DQS Oscillator Granularity Error is:

$$\text{DQS Oscillator Granularity Error} = \frac{2 * (0.8\text{nS})}{100\text{nS}} = 1.6\%$$

This equates to a granularity timing error of 12.8pS.

Assuming a circuit Matching Error of 5.5pS across voltage and temperature, then the accuracy is:

$$\text{DQS Oscillator Accuracy} = 1 - \frac{12.8 + 5.5}{800} = 97.7\%$$

**Example:** Running the DQS Oscillator for a longer period improves the accuracy. If the total time between start and stop commands is 500nS, and the maximum DQS clock tree delay is 800pS (tDQS2DQ max), then the DQS Oscillator Granularity Error is:

$$\text{DQS Oscillator Granularity Error} = \frac{2 * (0.8\text{nS})}{500\text{nS}} = 0.32\%$$

This equates to a granularity timing error or 2.56pS.

Assuming a circuit Matching Error of 5.5pS across voltage and temperature, then the accuracy is:

$$\text{DQS Oscillator Accuracy} = 1 - \frac{2.56 + 5.5}{800} = 99.0\%$$

The result of the DQS Interval Oscillator is defined as the number of DQS Clock Tree Delays that can be counted within the "run time," determined by the controller. The result is stored in MR18-OP[7:0] and MR19-OP[7:0]. MR18 contains the least significant bits (LSB) of the result, and MR19 contains the most significant bits (MSB) of the result. MR18 and MR19 are overwritten by the SDRAM when a MPC-1 [Stop DQS Osc] command is received. The SDRAM counter will count to its maximum value (=2<sup>16</sup>) and stop. If the maximum value is read from the mode registers, then the memory controller must assume that the counter overflowed the register and discard the result. The longest "run time" for the oscillator that will not overflow the counter registers can be calculated as follows:

$$\text{Longest Run Time Interval} = 2^{16} * \text{tDQS2DQ}(\text{min}) = 2^{16} * 0.2\text{nS} = 13.1\mu\text{S}$$



### 7.4.33.1 Interval Oscillator matching error

The interval oscillator matching error is defined as the difference between the DQS training ckt (interval oscillator) and the actual DQS clock tree across voltage and temperature.

- Parameters:
  - $t_{DQS2DQ}$ : Actual DQS clock tree delay
  - $t_{DQS_{osc}}$ : Training ckt(interval oscillator) delay
  - $OSC_{offset}$ : Average delay difference over voltage and temp (shown in Figure118)
  - $OSC_{Match}$ : DQS oscillator matching error

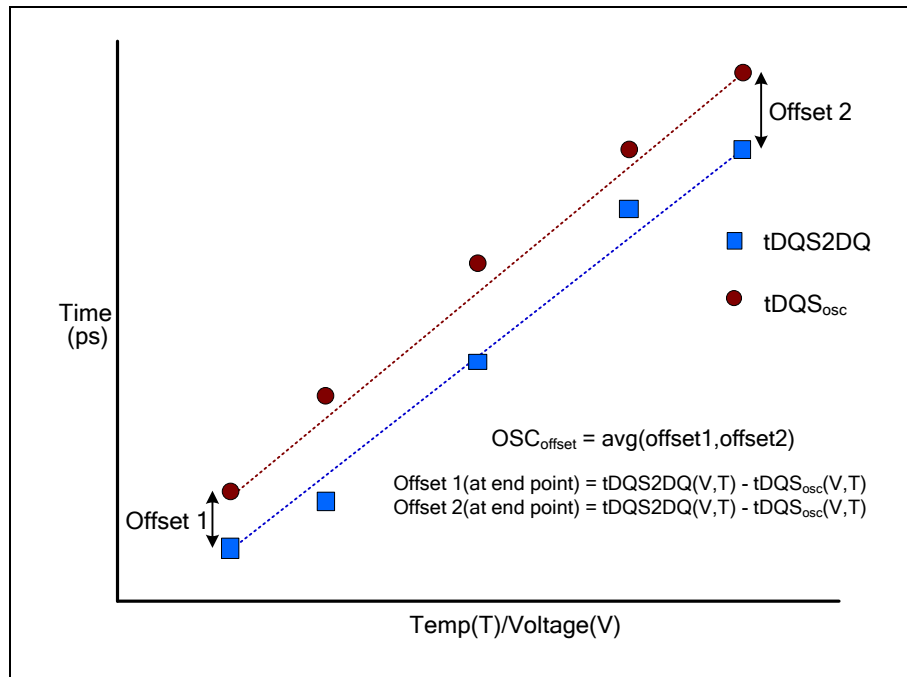

Figure 118 - Interval oscillator offset  $OSC_{offset}$

- $OSC_{Match}$ :

$$OSC_{Match} = [t_{DQS2DQ}(V,T) - t_{DQS_{osc}}(V,T) - OSC_{offset}]$$

- $t_{DQS_{osc}}$ :

$$t_{DQS_{osc}}(V,T) = \frac{Runtime}{2 * Count}$$



Table 65 - DQS Oscillator Matching Error Specification

Parameter	Symbol	Min	Max	Unit	Notes
DQS Oscillator Matching Error	OSCMatch	-20	20	pS	1,2,3,4,5,6,7
DQS Oscillator Offset	OSCOffset	-100	100	pS	2,4,7

**Notes:**

1. The OSCMatch is the matching error per between the actual DQS and DQS interval oscillator over voltage and temp.
2. This parameter will be characterized or guaranteed by design.
3. The OSCMatch is defined as the following:

$$OSCMatch = [tDQS2DQ(V,T) - tDQSosc(V,T) - OSCoffset]$$

Where tDQS2DQ(V,T) and tDQSosc(V,T) are determined over the same voltage and temp conditions.

4. The runtime of the oscillator must be at least 200ns for determining tDQSosc(V,T).

$$tDQSosc(V,T) = \frac{Runtime}{2 * Count}$$

5. The input stimulus for tDQS2DQ will be consistent over voltage and temp conditions.
6. The OSCoffset is the average difference of the endpoints across voltage and temp.
7. These parameters are defined per channel.
8. tDQS2DQ(V,T) delay will be the average of DQS to DQ delay over the runtime period.

**7.4.33.2 DQS Interval Oscillator Readout Timing**

OSC Stop to its counting value readout timing is shown in Figure 119 and Figure 120.

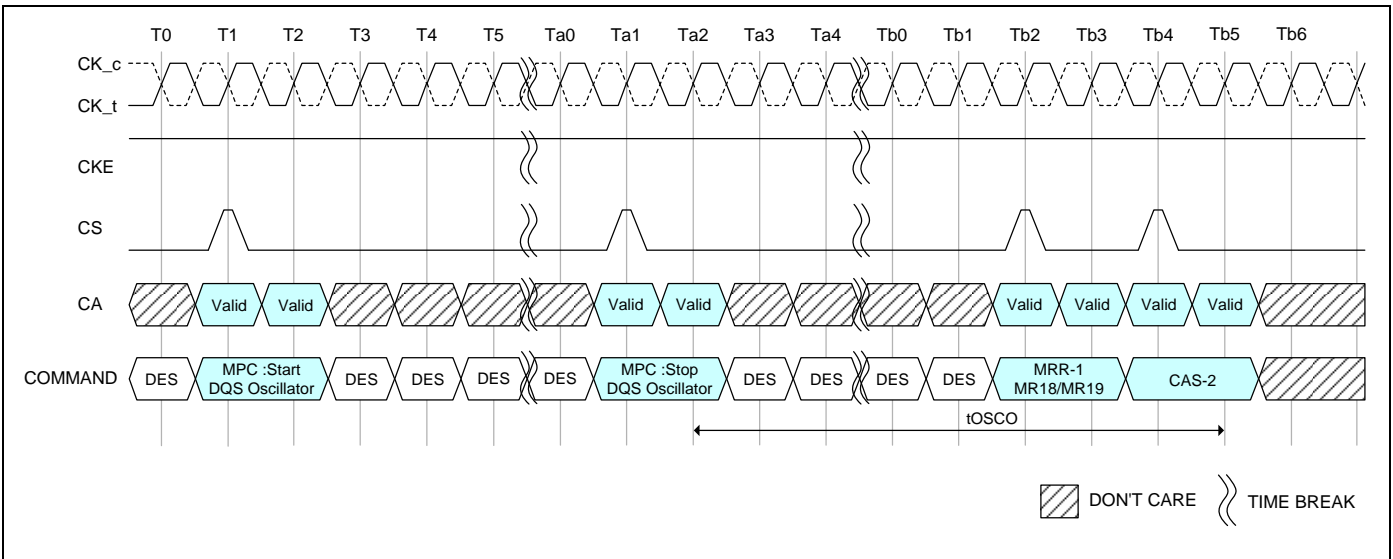

**Notes:**

1. DQS interval timer run time setting: MR23 OP[7:0] = 00000000.
2. DES commands are shown for ease of illustration; other commands may be valid at these times.

**Figure 119 - In case of DQS Interval Oscillator is stopped by MPC Command**

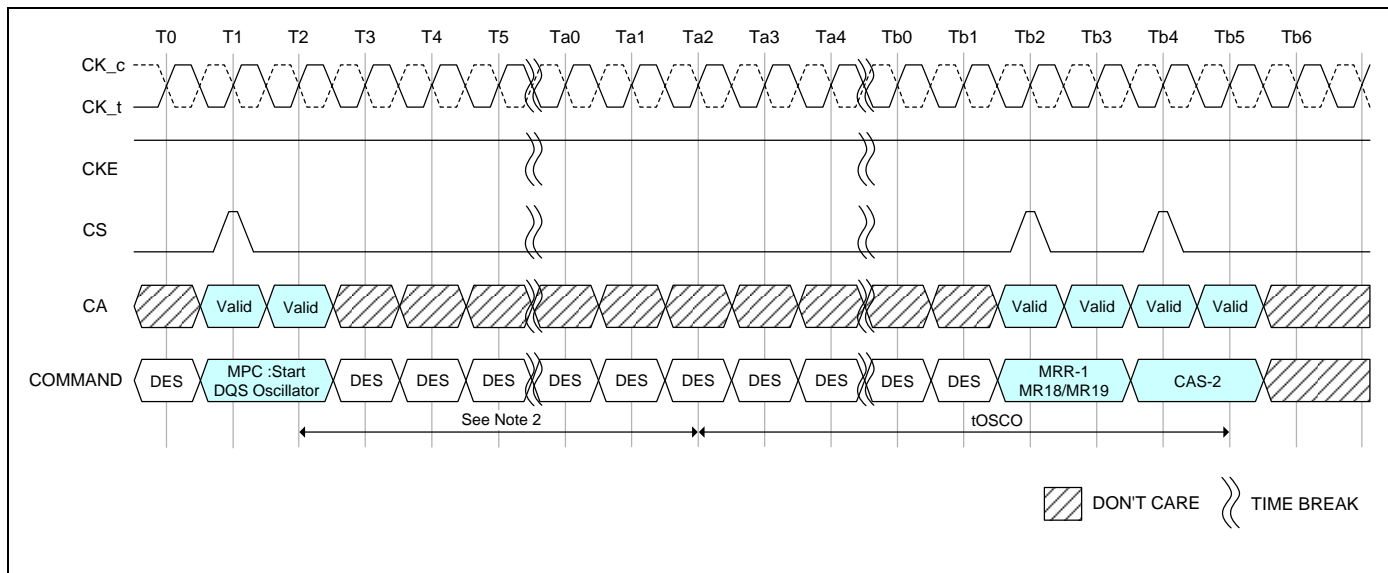

**Notes:**

1. DQS interval timer run time setting : MR23 OP[7:0] ≠ 00000000.
2. Setting counts of MR23.
3. DES commands are shown for ease of illustration; other commands may be valid at these times.

**Figure 120 - In case of DQS Interval Oscillator is stopped by DQS interval timer**

**Table 66 - DQS Interval Oscillator AC Timing**

Parameter	Symbol	Min/Max	Value	Unit	Note
Delay time from OSC stop to Mode Register Readout	tOSCO	Min	Max(40nS,8nCK)	nS	

**Note:**

1. Start DQS OSC command is prohibited until tOSCO(Min) is satisfied.



**7.4.34 READ Preamble Training**

LPDDR4X READ Preamble Training is supported through the MPC function. This mode can be used to train or read level the DQS receivers. Once READ Preamble Training is enabled by MR13[OP1] = 1, the LPDDR4X DRAM will drive DQS\_t LOW, DQS\_c HIGH within tSDO and remain at these levels until an MPC DQ READ Calibration command is issued.

During READ Preamble Training the DQS preamble provided during normal operation will not be driven by the DRAM. Once the MPC DQ READ Calibration command is issued, the DRAM will drive DQS\_t/DQS\_c and DQ like a normal READ burst after RL and tDQSK. Prior to the MPC DQ READ Calibration command, the DRAM may or may not drive DQ[15:0] in this mode.

While in READ Preamble Training Mode, only READ DQ Calibration commands may be issued.

- Issue an MPC [RD DQ Calibration] command followed immediately by a CAS-2 command.
- Each time an MPC [RD DQ Calibration] command followed by a CAS-2 is received by the LPDDR4X SDRAM, a 16-bit data burst will, after the currently set RL, drive the eight bits programmed in MR32 followed by the eight bits programmed in MR40 on all I/O pins.
- The data pattern will be inverted for I/O pins with a '1' programmed in the corresponding invert mask mode register bit.
- Note that the pattern is driven on the DMI pins, but no data bus inversion function is enabled, even if Read DBI is enabled in the DRAM mode register.
- This command can be issued every tCCD seamlessly.
- The operands received with the CAS-2 command must be driven LOW.

READ Preamble Training is exited within tSDO after setting MR13[OP1] = 0.

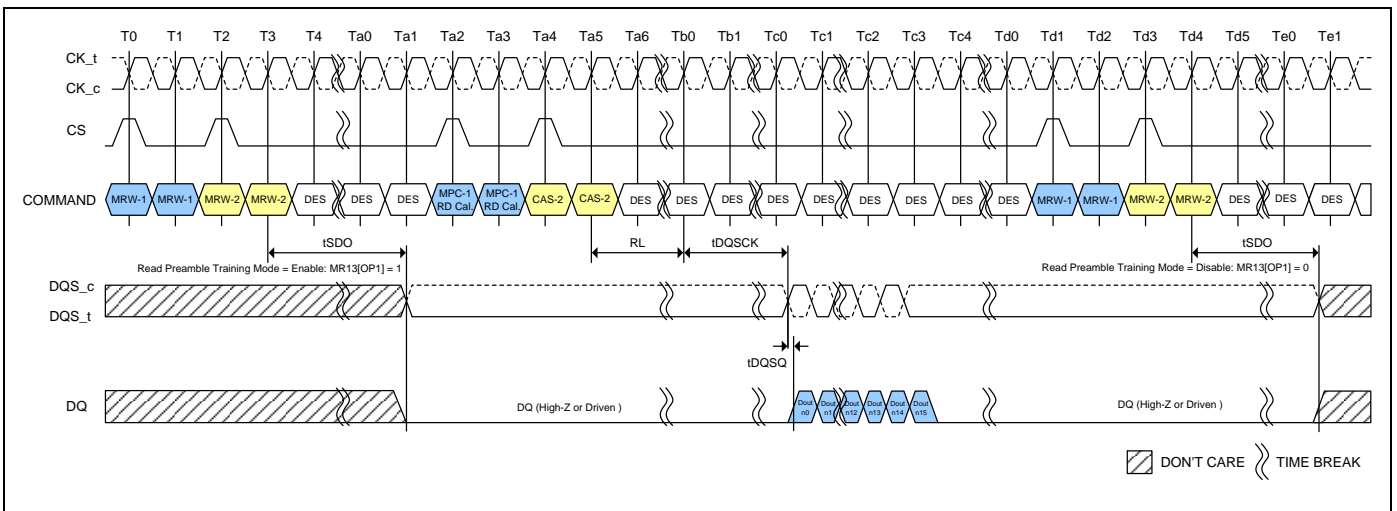

**Note:**

1. Read DQ Calibration supports only BL16 operation.

**Figure 121 - Read Preamble Training**

**Table 67 - Timing Parameters**

Parameter	Symbol	Min	Max	Unit	Note
Delay from MRW command to DQS Driven	tSDO	-	Max(12nCK, 20nS)	-	





**7.4.35 Multi-Purpose Command (MPC)**

LPDDR4X-SDRAMs use the MPC command to issue a NOP and to access various training modes. The MPC command is initiated with CS, and CA[5:0] asserted to the proper state at the rising edge of CK, as defined by the Command Truth Table. The MPC command has seven operands (OP[6:0]) that are decoded to execute specific commands in the SDRAM. OP[6] is a special bit that is decoded on the first rising CK edge of the MPC command. When OP[6]=0 then the SDRAM executes a NOP (no operation) command, and when OP[6]=1 then the SDRAM further decodes one of several training commands.

When OP[6]=1 and when the training command includes a Read or Write operation, the MPC command must be followed immediately by a CAS-2 command. For training commands that Read or Write the SDRAM, read latency (RL) and write latency (WL) are counted from the second rising CK edge of the CAS-2 command with the same timing relationship as any normal Read or Write command. The operands of the CAS-2 command following a MPC Read/Write command must be driven LOW.

The following MPC commands must be followed by a CAS-2 command:

- Write FIFO
- Read FIFO
- Read DQ Calibration

All other MPC-1 commands do not require a CAS-2 command, including:

- NOP
- Start DQS Interval Oscillator
- Stop DQS Interval Oscillator
- Start ZQ Calibration
- Latch ZQ Calibration

**Table 68 - MPC Command Definition**

SDRAM Command	SDR Command Pins			SDR CA Pins						CK_t EDGE	Notes
	CKE		CS	CA0	CA1	CA2	CA3	CA4	CA5		
	CK_t(n-1)	CK_t(n)									
MPC (Train, NOP)	H	H	H	L	L	L	L	L	OP6	R1	1, 2
			L	OP0	OP1	OP2	OP3	OP4	OP5	R2	

**Table 69 - MPC Command Definition for OP[6:0]**

Function	Operand	Data	Notes
Training Modes	OP[6:0]	<b>0XXXXXX<sub>b</sub></b> : NOP <b>1000001<sub>b</sub></b> : RD FIFO: RD FIFO supports only BL16 operation <b>1000011<sub>b</sub></b> : RD DQ Calibration (MR32/MR40) <b>1000101<sub>b</sub></b> : RFU <b>1000111<sub>b</sub></b> : WR FIFO: WR FIFO supports only BL16 operation <b>1001001<sub>b</sub></b> : RFU <b>1001011<sub>b</sub></b> : Start DQS Osc <b>1001101<sub>b</sub></b> : Stop DQS Osc <b>1001111<sub>b</sub></b> : ZQCal Start <b>1010001<sub>b</sub></b> : ZQCal Latch All Others: Reserved	1, 2, 3

**Notes:**

1. See command truth table for more information.
2. MPC commands for Read or Write training operations must be immediately followed by CAS-2 command consecutively without any other commands in-between. MPC command must be issued first before issuing the CAS-2 command.
3. Write FIFO and Read FIFO commands will only operate as BL16, ignoring the burst length selected by MR1 OP[1:0].



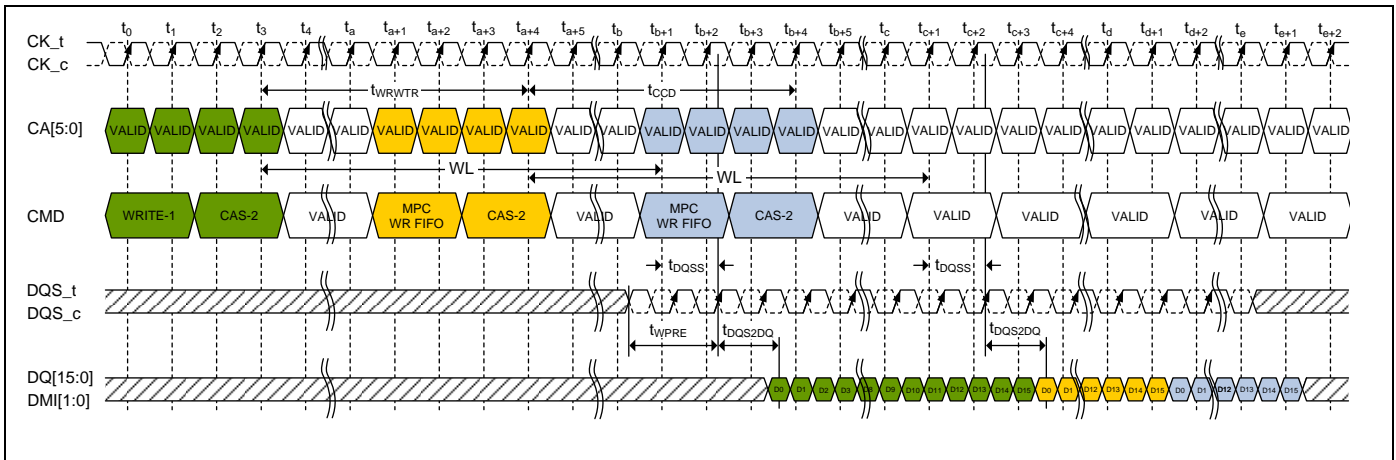

**Notes:**

1. MPC [WR FIFO] can be executed with a single bank or multiple banks active, during Refresh, or during SREF with CKE HIGH.
2. Write-1 to MPC is shown as an example of command-to-command timing for MPC. Timing from Write-1 to MPC [WR-FIFO] is  $t_{WRWTR}$ .
3. Seamless MPC [WR-FIFO] commands may be executed by repeating the command every  $t_{CCD}$  time.
4. MPC [WR-FIFO] uses the same command-to-data timing relationship ( $WL$ ,  $t_{DQSS}$ ,  $t_{DQSS2DQ}$ ) as a Write-1 command.
5. A maximum of 5 MPC [WR-FIFO] commands may be executed consecutively without corrupting FIFO data.  
The 6th MPC [WR-FIFO] command will overwrite the FIFO data from the first command. If fewer than 5 MPC [WR-FIFO] commands are executed, then the remaining FIFO locations will contain undefined data.
6. For the CAS-2 command following a MPC command, the CAS-2 operands must be driven "LOW".
7. To avoid corrupting the FIFO contents, MPC-1 [RD-FIFO] must immediately follow MPC-1 [WR-FIFO]/CAS-2 without any other command disturbing FIFO pointers in-between. FIFO pointers are disturbed by CKE Low, Write, Masked Write, Read, Read DQ Calibration and MRR. See Write Training session for more information on FIFO pointer behavior.

**Figure 122 - MPC [WRITE FIFO] Operation:  $t_{WPST}=2nCK$ ,  $t_{WPST}=0.5nCK$**

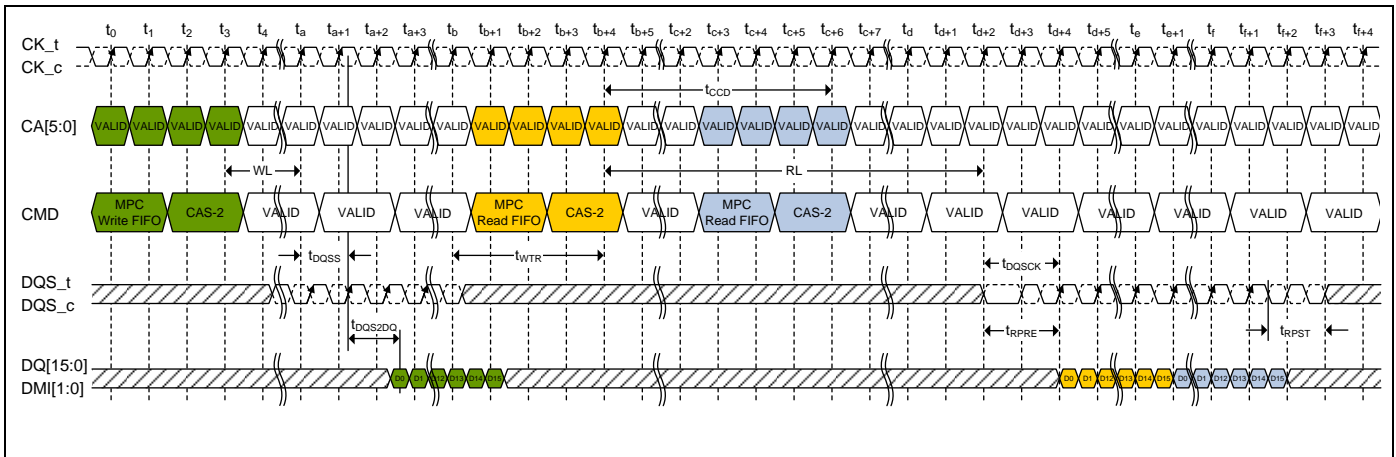

**Notes:**

1. MPC [WR FIFO] can be executed with a single bank or multiple banks active, during Refresh, or during SREF with CKE HIGH.
2. Write-1 to MPC is shown as an example of command-to-command timing for MPC. Timing from Write-1 to MPC [WR-FIFO] is  $t_{WRWTR}$ .
3. Seamless MPC [RD-FIFO] commands may be executed by repeating the command every  $t_{CCD}$  time.
4. MPC [WR-FIFO] uses the same command-to-data timing relationship ( $WL$ ,  $t_{DQSS}$ ,  $t_{DQSS2DQ}$ ) as a Write-1 command.
5. Data may be continuously read from the FIFO without any data corruption. After 5 MPC [RD-FIFO] commands the FIFO pointer will wrap back to the 1st FIFO and continue advancing. If fewer than 5 MPC [WR-FIFO] commands were executed, then the MPC [RD-FIFO] commands to those FIFO locations will return undefined data. See the Write Training section for more information on the FIFO pointer behavior.
6. For the CAS-2 command immediately following a MPC command, the CAS-2 operands must be driven "LOW".
7. DMI[1:0] signals will be driven if any of WR-DBI, RD-DBI, or DM is enabled in the mode registers. See Write Training section for more information on DMI behavior.

**Figure 123 - MPC [RD FIFO] Read Operation:  $t_{WPST}=2nCK$ ,  $t_{WPST}=0.5nCK$ ,  $t_{RPST}=toggling$ ,  $t_{RPST}=1.5nCK$**

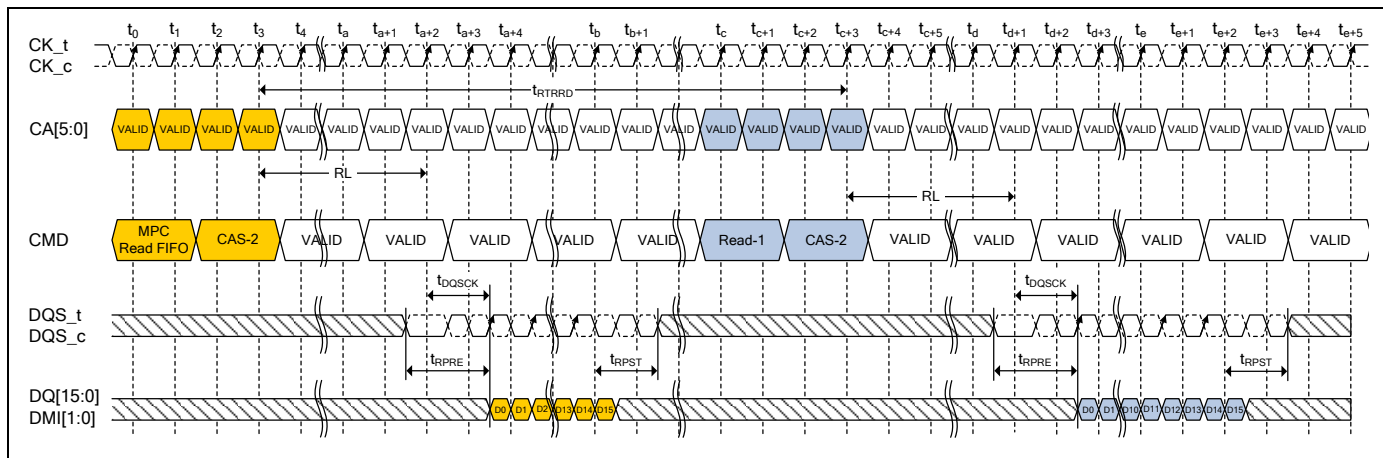

**Notes:**

1. MPC [WR FIFO] can be executed with a single bank or multiple banks active, during Refresh, or during SREF with CKE HIGH.
2. MPC [RD-FIFO] to Read-1 Operation is shown as an example of command-to-command timing for MPC. Timing from MPC-1 [RD-FIFO] command to Read is  $t_{TRRD}$ .
3. Seamless MPC [RD-FIFO] commands may be executed by repeating the command every  $t_{CCD}$  time.
4. MPC [RD-FIFO] uses the same command-to-data timing relationship (RL,  $t_{DQSCK}$ ) as a Read-1 command.
5. Data may be continuously read from the FIFO without any data corruption. After 5 MPC [RD-FIFO] commands the FIFO pointer will wrap back to the 1st FIFO and continue advancing. If fewer than 5 MPC [WR-FIFO] commands were executed, then the MPC [RD-FIFO] commands to those FIFO locations will return undefined data. See the Write Training section for more information on the FIFO pointer behavior.
6. For the CAS-2 command immediately following a MPC command, the CAS-2 operands must be driven "LOW".
7. DMI[1:0] signals will be driven if any of WR-DBI, RD-DBI, or DM is enabled in the mode registers. See Write Training section for more information on DMI behavior.

**Figure 124 - MPC [RD FIFO] Operation:  $t_{RPRE}$ =toggling,  $t_{RPST}$ =1.5nCK**



Table 70 - Timing Constraints for Training Commands

Previous Command	Next Command	Minimum Delay	Unit	Notes
WR/MWR	MPC [WR FIFO]	tWRWTR	nCK	1
	MPC [RD FIFO]	Not Allowed	-	2
	MPC [RD DQ Calibration]	WL+RU(tDQSS(max)/tCK) +BL/2+RU(tWTR/tCK)	nCK	
RD/MRR	MPC [WR FIFO]	tRTW	nCK	3
	MPC [RD FIFO]	Not Allowed	-	2
	MPC [RD DQ Calibration]	tRTRRD	nCK	3
MPC [WR FIFO]	WR/MWR	Not Allowed	-	2
	MPC [WR FIFO]	tCCD	nCK	
	RD/MRR	Not Allowed	-	2
	MPC [RD FIFO]	WL+RU(tDQSS(max)/tCK) +BL/2+RU(tWTR/tCK)	nCK	
	MPC [RD DQ Calibration]	Not Allowed	-	2
MPC [RD FIFO]	WR/MWR	tRTW	nCK	3
	MPC [WR FIFO]	tRTW	nCK	4
	RD/MRR	tRTRRD	nCK	3
	MPC [RD FIFO]	tCCD	nCK	
	MPC [RD DQ Calibration]	tRTRRD	nCK	3
MPC [RD DQ Calibration]	WR/MWR	tRTW	nCK	3
	MPC [WR FIFO]	tRTW	nCK	3
	RD/MRR	tRTRRD	nCK	3
	MPC [RD FIFO]	Not Allowed	-	2
	MPC [RD DQ Calibration]	tCCD	nCK	

**Notes:**

- $t_{WRWTR} = WL + BL/2 + RU(t_{DQSS(max)}/t_{CK}) + \max(RU(7.5nS/t_{CK}), 8nCK)$ .
- No commands are allowed between MPC [WR FIFO] and MPC-1 [RD FIFO] except MRW commands related to training parameters.
- $t_{RTRRD} = RL + RU(t_{DQSCK(max)}/t_{CK}) + BL/2 + RD(t_{RPST}) + \max(RU(7.5nS/t_{CK}), 8nCK)$ .
- tRTW:  
 In Case of DQ ODT Disable MR11 OP[2:0] = 000<sub>b</sub>:  
 $RL + RU(t_{DQSCK(max)}/t_{CK}) + BL/2 - WL + t_{WPRES} + RD(t_{RPST})$   
 In Case of DQ ODT Enable MR11 OP[2:0] ≠ 000<sub>b</sub>:  
 $RL + RU(t_{DQSCK(max)}/t_{CK}) + BL/2 + RD(t_{RPST}) - ODTL_{on} - RD(t_{ODT_{on,min}}/t_{CK}) + 1$



### 7.4.36 Thermal Offset

Because of their tight thermal coupling with the LPDDR4X device, hot spots on an SOC can induce thermal gradients across the LPDDR4X device. As these hot spots may not be located near the device thermal sensor, the devices' temperature compensated Self Refresh circuit may not generate enough refresh cycles to guarantee memory retention. To address this shortcoming, the controller can provide a thermal offset that the memory uses to adjust its TCSR circuit to ensure reliable operation.

This offset is provided through MR4[6:5] to either or both the channels (dual-channel devices). This temperature offset may modify refresh behavior for the channel to which the offset is provided. It will take a max of 200us to have the change reflected in MR4[2:0] for the channel to which the offset is provided. If the induced thermal gradient from the device temperature sensor location to the hot spot location of the controller is larger than 15 degrees C, then Self Refresh mode will not reliably maintain memory contents.

To accurately determine the temperature gradient between the memory thermal sensor and the induced hot spot, the memory thermal sensor location must be provided to the LPDDR4X memory controller.

### 7.4.37 Temperature Sensor

LPDDR4X devices feature a temperature sensor whose status can be read from MR4. This sensor can be used to determine an appropriate refresh rate, determine whether AC timing de-rating is required in the elevated temperature range, and/or monitor the operating temperature. Either the temperature sensor or the device TOPER may be used to determine whether operating temperature requirements are being met.

LPDDR4X devices shall monitor device temperature and update MR4 according to tTSI. Upon assertion of CKE (Low to High transition), the device temperature status bits shall be no older than tTSI. MR4 will be updated even when device is in Self Refresh state with CKE HIGH.

When using the temperature sensor, the actual device case temperature may be higher than the TOPER specification that applies for the standard or elevated temperature ranges. For example, TCASE may be above 85°C when MR4[2:0] equals 'b011'. LPDDR4X devices shall allow for 2°C temperature margin between the point at which the device updates the MR4 value and the point at which the controller reconfigures the system accordingly. In the case of tight thermal coupling of the memory device to external hot spots, the maximum device temperature might be higher than what is indicated by MR4.

To assure proper operation using the temperature sensor, applications should consider the following factors:

- TempGradient is the maximum temperature gradient experienced by the memory device at the temperature of interest over a range of 2°C.
- ReadInterval is the time period between MR4 reads from the system.
- TempSensorInterval (tTSI) is maximum delay between internal updates of MR4.
- SysRespDelay is the maximum time between a read of MR4 and the response by the system.

In order to determine the required frequency of polling MR4, the system shall use the maximum TempGradient and the maximum response time of the system using the following equation:

$$\text{TempGradient} \times (\text{ReadInterval} + \text{tTSI} + \text{SysRespDelay}) \leq 2^\circ\text{C}$$

Table 71 - Temperature Sensor

Parameter	Symbol	Min/Max	Value	Unit	Notes
System Temperature Gradient	TempGradient	Max	System Dependent	°C/s	
MR4 Read Interval	ReadInterval	Max	System Dependent	mS	
Temperature Sensor Interval	tTSI	Max	32	mS	
System Response Delay	SysRespDelay	Max	System Dependent	mS	
Device Temperature Margin	TempMargin	Max	-2	°C	



For example, if TempGradient is 10°C/s and the SysRespDelay is 1 mS:

$(10^{\circ}\text{C/s}) \times (\text{ReadInterval} + 32\text{mS} + 1\text{mS}) \leq 2^{\circ}\text{C}$

In this case, ReadInterval shall be no greater than 167 mS.

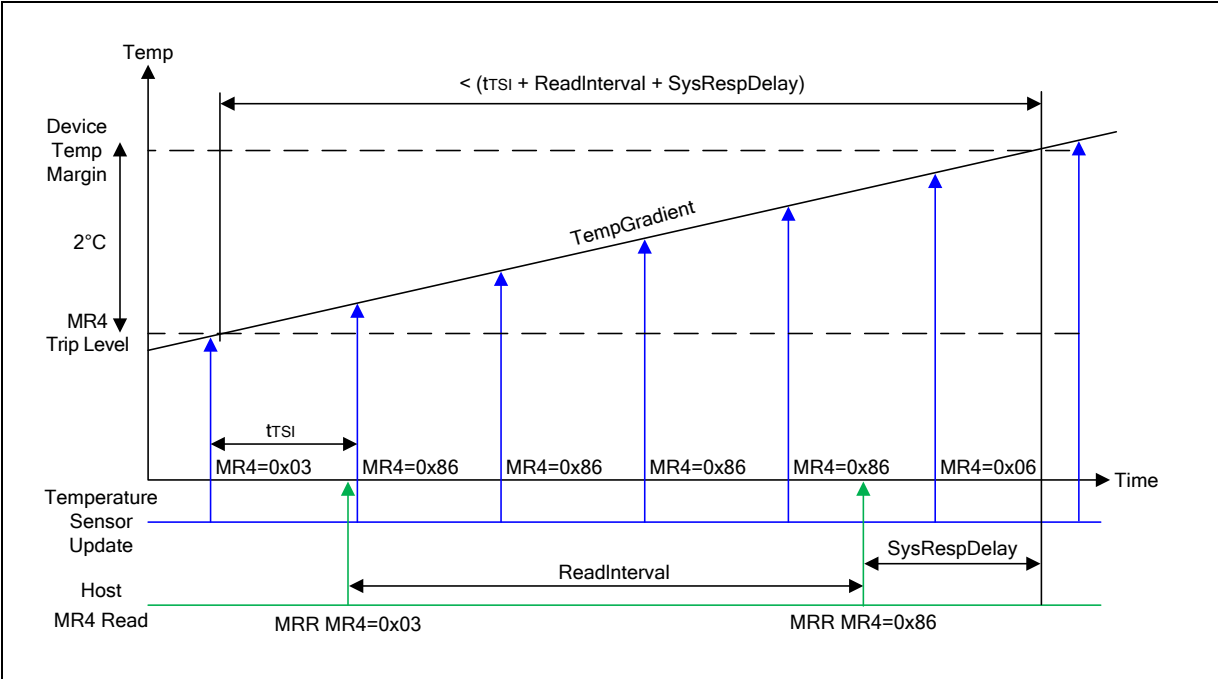

Figure 125 - Temp Sensor Timing



**7.4.38 ZQ Calibration**

The MPC command is used to initiate ZQ Calibration, which calibrates the output driver impedance across process, temperature, and voltage. ZQ Calibration occurs in the background of device operation.

There are two ZQ Calibration modes initiated with the MPC command: ZQCal Start, and ZQCal Latch. ZQCal Start initiates the SDRAM's calibration procedure, and ZQCal Latch captures the result and loads it into the SDRAM's drivers.

A ZQCal Start command may be issued anytime the LPDDR4X-SDRAM is not in a power-down state. A ZQCal Latch Command may be issued anytime outside of power-down after tZQCAL has expired and all DQ bus operations have completed. The CA Bus must maintain a Deselect state during tZQLAT to allow CA ODT calibration settings to be updated. The following mode register fields that modify I/O parameters cannot be changed following a ZQCal Start command and before tZQCAL has expired:

- PU-Cal (Pull-up Calibration VOH Point)
- PDDS (Pull Down Drive Strength and Rx Termination)
- DQ-ODT (DQ ODT Value)
- CA-ODT (CA ODT Value)

**7.4.38.1 ZQCal Reset**

The ZQCal Reset command resets the output impedance calibration to a default accuracy of +/- 30% across process, voltage, and temperature. This command is used to ensure output impedance accuracy to +/- 30% when ZQCal Start and ZQCal Latch commands are not used.

The ZQCal Reset command is executed by writing MR10 OP[0]=1B.

**Table 72 - ZQCal Timing Parameters**

Parameter	Symbol	Min/Max	Value	Unit
ZQ Calibration Time	tZQCAL	Min	1	μS
ZQ Calibration Latch Time	tZQLAT	Min	max(30nS,8nCK)	nS
ZQ Calibration Reset Time	tZQRESET	Min	max(50nS,3nCK)	nS

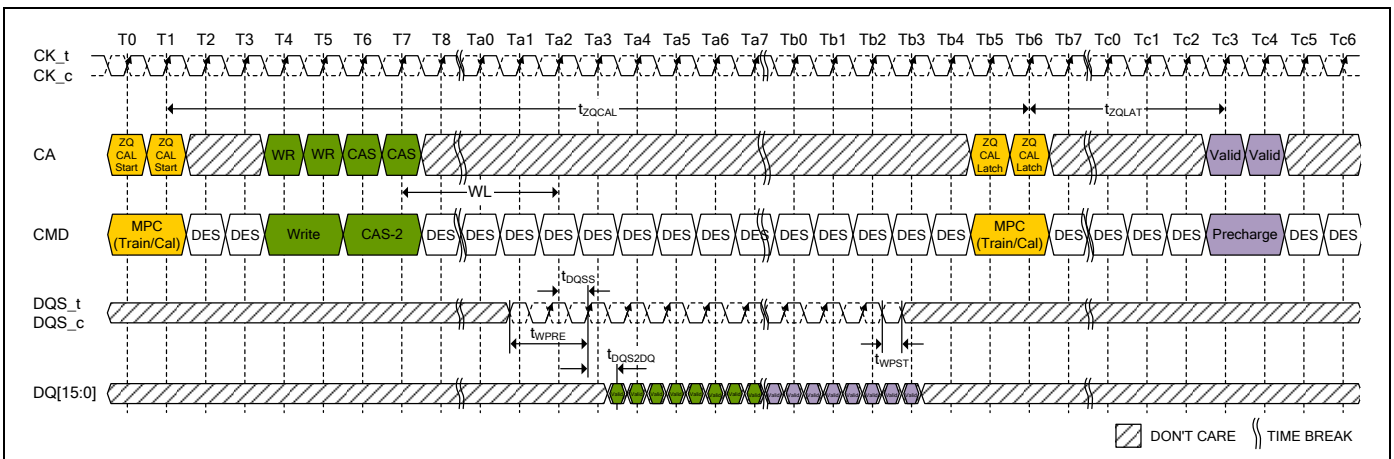

**Notes:**

1. Write and Precharge operations shown for illustrative purposes.  
Any single or multiple valid commands may be executed within the tZQCAL time and prior to latching the results.
2. Before the ZQ-Latch command can be executed, any prior commands utilizing the DQ bus must have completed.  
Write commands with DQ Termination must be given enough time to turn off the DQ-ODT before issuing the ZQ-Latch command.  
See the ODT section for ODT timing.

**Figure 126 - ZQCal Timing**





### 7.4.38.2 ZQ External Resistor, Tolerance, and Capacitive Loading

To use the ZQ calibration function, a 240 ohm  $\pm 1\%$  tolerance external resistor must be connected between the ZQ pin and VDDQ.

If the system configuration shares the CA bus to form an x32 (or wider) channel, the ZQ pin of each die's x16 channel shall use a separate ZQCal resistor.

If the system configuration has more than one rank, and if the ZQ pins of both ranks are attached to a single resistor, then the SDRAM controller must ensure that the ZQCal's don't overlap.

The total capacitive loading on the ZQ pin must be limited to 25pF.

Example: If a system configuration shares a CA bus between 'n' channels to form a  $n \times 16$  wide bus, and no means are available to control the ZQCal separately for each channel (i.e., separate CS, CKE, or CK), then each x16 channel must have a separate ZQCal resistor.

Example: For an x32, two rank system, each x16 channel must have its own ZQCal resistor, but the ZQCal resistor can be shared between ranks on each x16 channel. In this configuration, the CS signal can be used to ensure that the ZQCal commands for Rank[0] and Rank[1] don't overlap.

### 7.4.39 Pull Up/Pull Down Driver Characteristics and Calibration

**Table 73 - Pull-down Driver Characteristics, with ZQ Calibration**

RONPD,nom	Resistor	Min	Nom	Max	Unit
40 Ohm	RON40PD	0.9	1	1.1	RZQ/6
48 Ohm	RON48PD	0.9	1	1.1	RZQ/5
60 Ohm	RON60PD	0.9	1	1.1	RZQ/4
80 Ohm	RON80PD	0.9	1	1.1	RZQ/3
120 Ohm	RON120PD	0.9	1	1.1	RZQ/2
240 Ohm	RON240PD	0.9	1	1.1	RZQ/1

**Note:**

1. All value are after ZQ Calibration. Without ZQ Calibration RONPD values are  $\pm 30\%$ .

**Table 74 - Terminated Pull-Up Characteristics, with ZQ Calibration**

VOHPU,nom	VOH,nom(mV)	Min	Nom	Max	Unit
VDDQ*0.5	300	0.9	1	1.1	VOH,nom
VDDQ*0.6	360	0.9	1	1.1	VOH,nom

**Notes:**

- All values are after ZQ Calibration. Without ZQ Calibration VOH(nom) values are  $\pm 30\%$ .
- VOH,nom (mV) values are based on a nominal VDDQ = 0.6V.

**Table 75 - Terminated Valid Calibration Points**

VOHPU,nom	SOC ODT Value					
	240	120	80	60	48	40
VDDQ*0.5	VALID	VALID	VALID	VALID	VALID	VALID
VDDQ*0.6	DNU	VALID	DNU	VALID	DNU	DNU

**Notes:**

- Once the output is calibrated for a given VOH(nom) calibration point, the ODT value may be changed without recalibration.
- If the VOH(nom) calibration point is changed, then re-calibration is required.
- DNU = Do Not Use.



**7.4.40 On Die Termination for Command/Address Bus**

ODT (On-Die Termination) is a feature of the LPDDR4X SDRAM that allows the SDRAM to turn on/off termination resistance for CK<sub>t</sub>, CK<sub>c</sub>, CS and CA[5:0] signals without the ODT control pin.

The ODT feature is designed to improve signal integrity of the memory channel by allowing the DRAM controller to turn on and off termination resistance for any target DRAM devices via Mode Register setting.

A simple functional representation of the DRAM ODT feature is shown in Figure 127.

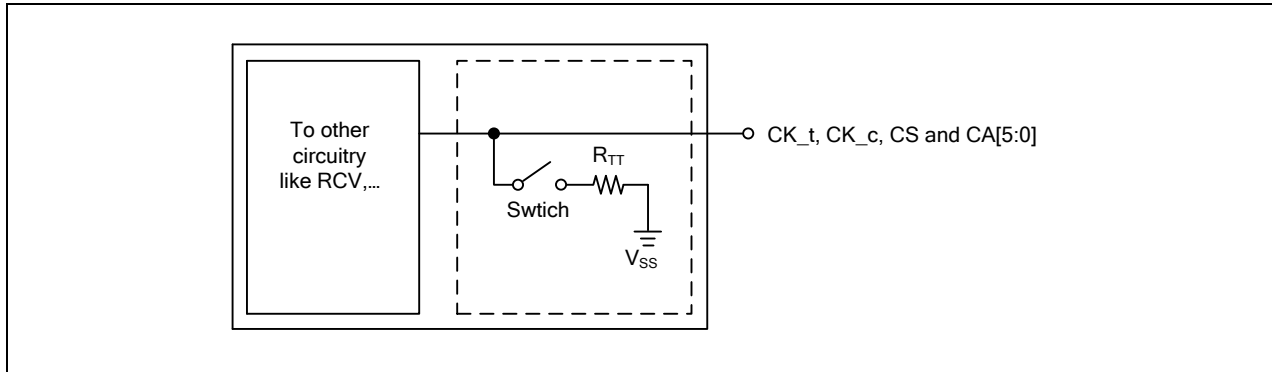

**Figure 127 - Functional Representation of CA ODT**

**7.4.40.1 ODT Mode Register and ODT State Table**

ODT termination values are set and enabled via MR11. The CA bus (CK<sub>t</sub>, CK<sub>c</sub>, CS, CA[5:0]) ODT resistance values are set by MR11 OP[6:4]. The default state for the CA is ODT disabled.

ODT is applied on the CA bus to the CK<sub>t</sub>, CK<sub>c</sub>, CS and CA[5:0] signals. Generally, only one termination load will be present even if multiple devices are sharing the command signals. In contrast to LPDDR4 where the ODT<sub>CA</sub> input is used in combination with mode registers, LPDDR4X uses mode registers exclusively to enable CA termination. Before enabling CA termination via MR11, all ranks should have appropriate MR22 termination settings programmed. In a multi rank system, the terminating rank should be trained first, followed by the nonterminating rank(s).

**Table 76 - Command Bus ODT State**

ODTE-CA MR11[6:4]	ODTD-CA MR22[5]	ODTF-CK MR22[3]	ODTF-CS MR22[4]	ODT State for CA	ODT State for CK <sub>t</sub> /CK <sub>c</sub>	ODT State for CS
Disabled*1	Valid*2	Valid*2	Valid*2	Off	Off	Off
Valid*2	0	0	0	On	On	On
Valid*2	0	0	1	On	On	Off
Valid*2	0	1	0	On	Off	On
Valid*2	0	1	1	On	Off	Off
Valid*2	1	0	0	Off	On	On
Valid*2	1	0	1	Off	On	Off
Valid*2	1	1	0	Off	Off	On
Valid*2	1	1	1	Off	Off	Off

**Notes:**

1. Default Value.
2. "Valid" means "0 or 1".





7.4.40.2 ODT Mode Register and ODT Characteristics

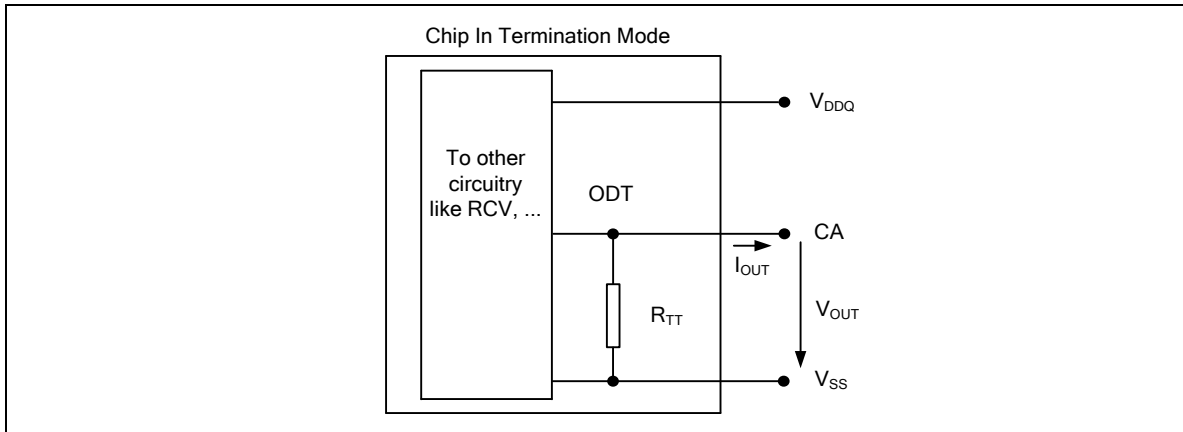

Figure 128 - On Die Termination for CA

$$R_{TT} = \frac{V_{out}}{|I_{out}|}$$



Table 77 - ODT DC Electrical Characteristics

(Assuming RZQ = 240 Ω ±1% over the entire operating temperature range after a proper ZQ calibration)

MR11[6:4]	R <sub>TT</sub>	V <sub>out</sub>	Min	Nom	Max	Unit	Notes
001	240 Ω	VOL <sub>dc</sub> = 0.20 * V <sub>DDQ</sub>	0.8	1.0	1.1	RZQ	1, 2
		VOM <sub>dc</sub> = 0.50 * V <sub>DDQ</sub>	0.9	1.0	1.1	RZQ	1, 2
		VOH <sub>dc</sub> = 0.75 * V <sub>DDQ</sub>	0.9	1.0	1.3	RZQ	1, 2
010	120 Ω	VOL <sub>dc</sub> = 0.20 * V <sub>DDQ</sub>	0.8	1.0	1.1	RZQ/2	1, 2
		VOM <sub>dc</sub> = 0.50 * V <sub>DDQ</sub>	0.9	1.0	1.1	RZQ/2	1, 2
		VOH <sub>dc</sub> = 0.75 * V <sub>DDQ</sub>	0.9	1.0	1.3	RZQ/2	1, 2
011	80 Ω	VOL <sub>dc</sub> = 0.20 * V <sub>DDQ</sub>	0.8	1.0	1.1	RZQ/3	1, 2
		VOM <sub>dc</sub> = 0.50 * V <sub>DDQ</sub>	0.9	1.0	1.1	RZQ/3	1, 2
		VOH <sub>dc</sub> = 0.75 * V <sub>DDQ</sub>	0.9	1.0	1.3	RZQ/3	1, 2
100	60 Ω	VOL <sub>dc</sub> = 0.20 * V <sub>DDQ</sub>	0.8	1.0	1.1	RZQ/4	1, 2
		VOM <sub>dc</sub> = 0.50 * V <sub>DDQ</sub>	0.9	1.0	1.1	RZQ/4	1, 2
		VOH <sub>dc</sub> = 0.75 * V <sub>DDQ</sub>	0.9	1.0	1.3	RZQ/4	1, 2
101	48 Ω	VOL <sub>dc</sub> = 0.20 * V <sub>DDQ</sub>	0.8	1.0	1.1	RZQ/5	1, 2
		VOM <sub>dc</sub> = 0.50 * V <sub>DDQ</sub>	0.9	1.0	1.1	RZQ/5	1, 2
		VOH <sub>dc</sub> = 0.75 * V <sub>DDQ</sub>	0.9	1.0	1.3	RZQ/5	1, 2
110	40 Ω	VOL <sub>dc</sub> = 0.20 * V <sub>DDQ</sub>	0.8	1.0	1.1	RZQ/6	1, 2
		VOM <sub>dc</sub> = 0.50 * V <sub>DDQ</sub>	0.9	1.0	1.1	RZQ/6	1, 2
		VOH <sub>dc</sub> = 0.75 * V <sub>DDQ</sub>	0.9	1.0	1.3	RZQ/6	1, 2
Mismatch CA-CA within clk group		0.50 * V <sub>DDQ</sub>	-		2	%	1, 2, 3

**Notes:**

1. The tolerance limits are specified after calibration with stable voltage and temperature. For the behavior of the tolerance limits if temperature or voltage changes after calibration, see following section on voltage and temperature sensitivity.
2. Pull-down ODT resistors are recommended to be calibrated at 0.5\*V<sub>DDQ</sub>. Other calibration schemes may be used to achieve the linearity spec shown above, e.g., calibration at 0.75\*V<sub>DDQ</sub> and 0.2\*V<sub>DDQ</sub>.
3. CA to CA mismatch within clock group (CA, CS) variation for a given component including CK\_t and CK\_c (characterized).

$$\text{CA - CA Mismatch} = \frac{\text{RODT(max)} - \text{RODT(min)}}{\text{RODT(avg)}}$$



7.4.40.3 ODT for Command/Address update time

ODT for Command/Address update time after Mode Register set are shown in Figure 129.

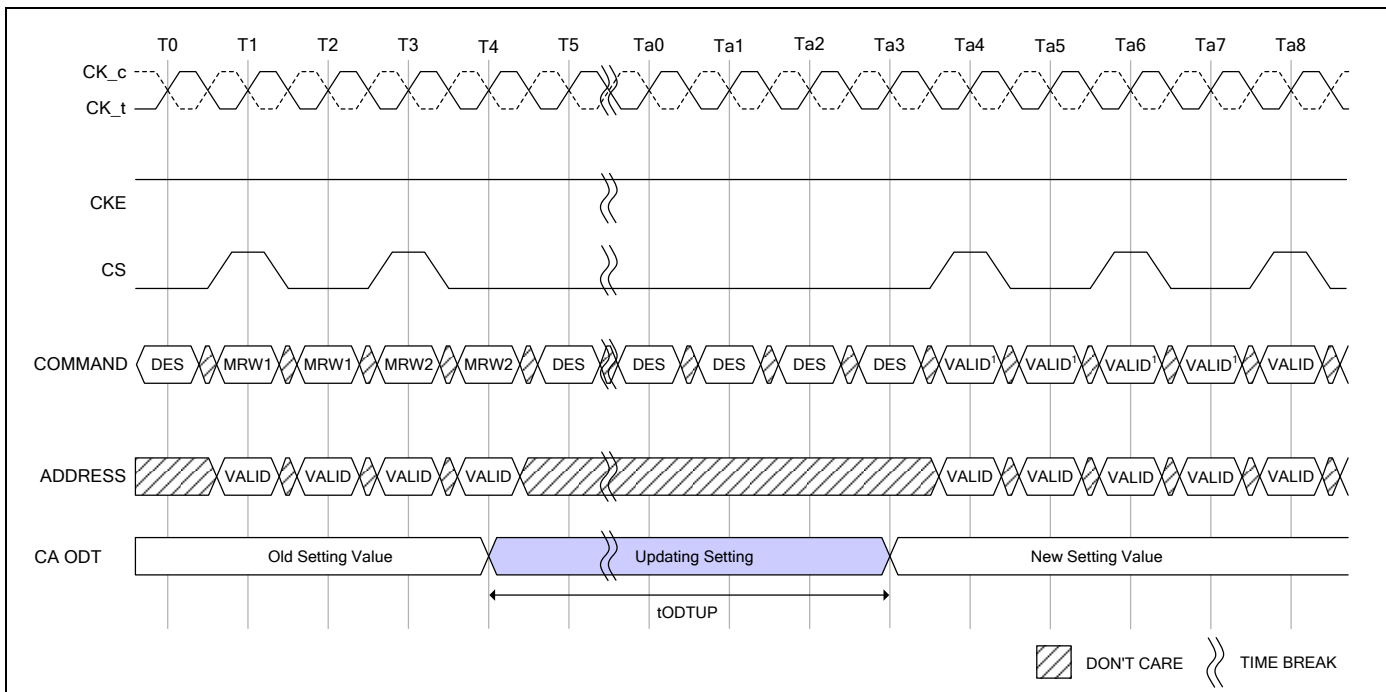

Note: 1. 4 Clock Cycle Command.

Figure 129 - ODT for Command/Address setting update timing in 4 Clock Cycle Command

Table 78 - ODT CA AC Timing

Speed		LPDDR4X-1600/1866/2133/2400/3200/3733/4267		Unit	Note
Parameter	Symbol	MIN	MAX		
ODT CA Value Update Time	tODTUP	RU(TBDnS/tCK(avg))	-		



#### 7.4.41 On-Die Termination

ODT (On-Die Termination) is a feature of the LPDDR4X SDRAM that allows the DRAM to turn on/off termination resistance for each DQ, DQS<sub>t</sub>, DQS<sub>c</sub> and DMI signals without the ODT control pin. The ODT feature is designed to improve signal integrity of the memory channel by allowing the DRAM controller to turn on and off termination resistance for any target DRAM devices during Write or Mask Write operation.

The ODT feature is off and cannot be supported in Power Down and Self Refresh modes.

A simple functional representation of the DRAM ODT feature is shown in Figure 130.

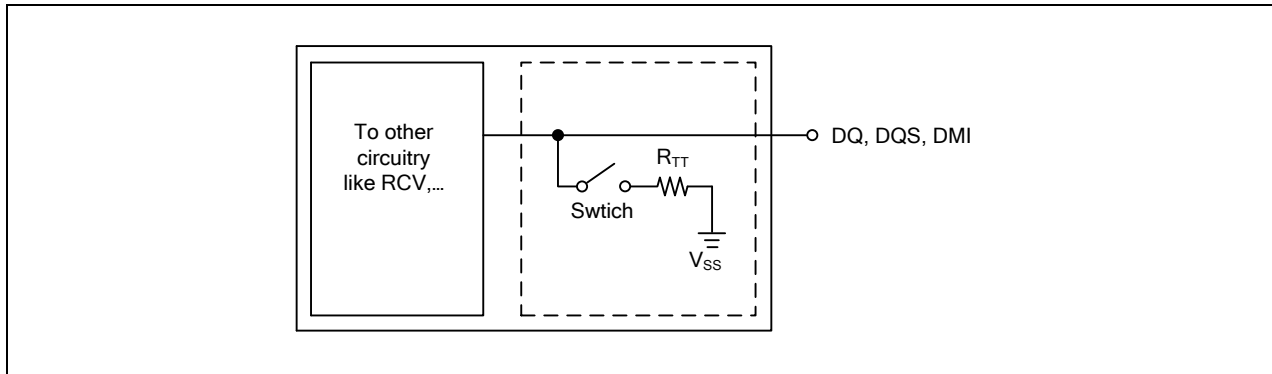

**Figure 130 - Functional Representation of ODT**

The switch is enabled by the internal ODT control logic, which uses the Write-1 or Mask Write-1 command and other mode register control information. The value of  $R_{TT}$  is determined by the settings of Mode Register bits.

##### 7.4.41.1 ODT Mode Register

The ODT Mode is enabled if MR11 OP[3:0] are non-zero. In this case, the value of  $R_{TT}$  is determined by the settings of those bits. The ODT Mode is disabled if MR11 OP[3] = 0.

##### 7.4.41.2 Asynchronous ODT

When ODT Mode is enabled in MR11 OP[3:0], DRAM ODT is always Hi-Z. DRAM ODT feature is automatically turned ON asynchronously based on the Write-1 or Mask Write-1 command that DRAM samples. After the write burst is complete, DRAM ODT featured is automatically turned OFF asynchronously.

Following timing parameters apply when DRAM ODT mode is enabled:

- ODTLon, tODTon,min, tODTon,max
- ODTLoff, tODToff,min, tODToff,max

ODTLon is a synchronous parameter and it is the latency from CAS-2 command to tODTon reference.

ODTLon latency is a fixed latency value for each speed bin. Each speed bin has a different ODTLon latency. Minimum  $R_{TT}$  turn-on time (tODTon,min) is the point in time when the device termination circuit leaves high impedance state and ODT resistance begins to turn on.

Maximum  $R_{TT}$  turn on time (tODTon,max) is the point in time when the ODT resistance is fully on. tODTon,min and tODTon,max are measured once ODTLon latency is satisfied from CAS-2 command.

ODTLoff is a synchronous parameter and it is the latency from CAS-2 command to tODToff reference.

ODTLoff latency is a fixed latency value for each speed bin. Each speed bin has a different ODTLoff latency.

Minimum  $R_{TT}$  turn-off time (tODToff,min) is the point in time when the device termination circuit starts to turn off the ODT resistance.

Maximum ODT turn off time (tODToff,max) is the point in time when the on-die termination has reached high impedance.

tODToff,min and tODToff,max are measured once ODTLoff latency is satisfied from CAS-2 command.



Table 79 - ODTLon and ODTLoff Latency Values

ODTLon Latency* <sup>1</sup>		ODTLoff Latency* <sup>2</sup>		Lower Clock Frequency Limit (>)	Upper Clock Frequency Limit (≤)
tWPRE = 2 tCK					
WL Set "A"	WL Set "B"	WL Set "A"	WL Set "B"		
N/A	N/A	N/A	N/A	10	266
N/A	N/A	N/A	N/A	266	533
N/A	6	N/A	22	533	800
4	12	20	28	800	1066
4	14	22	32	1066	1333
6	18	24	36	1333	1600
6	20	26	40	1600	1866
8	24	28	44	1866	2133
nCK	nCK	nCK	nCK	MHz	MHz

**Notes:**

1. ODTLon is referenced from CAS-2 command. See Figure 131.
2. ODTLoff as shown in table assumes BL=16. For BL32, 8 tCK should be added.

Table 80 - Asynchronous ODT Turn On and Turn Off Timing

Parameter	800 - 2133 MHz	Unit
tODTon, min	1.5	nS
tODTon, max	3.5	nS
tODTOff, min	1.5	nS
tODTOff, max	3.5	nS

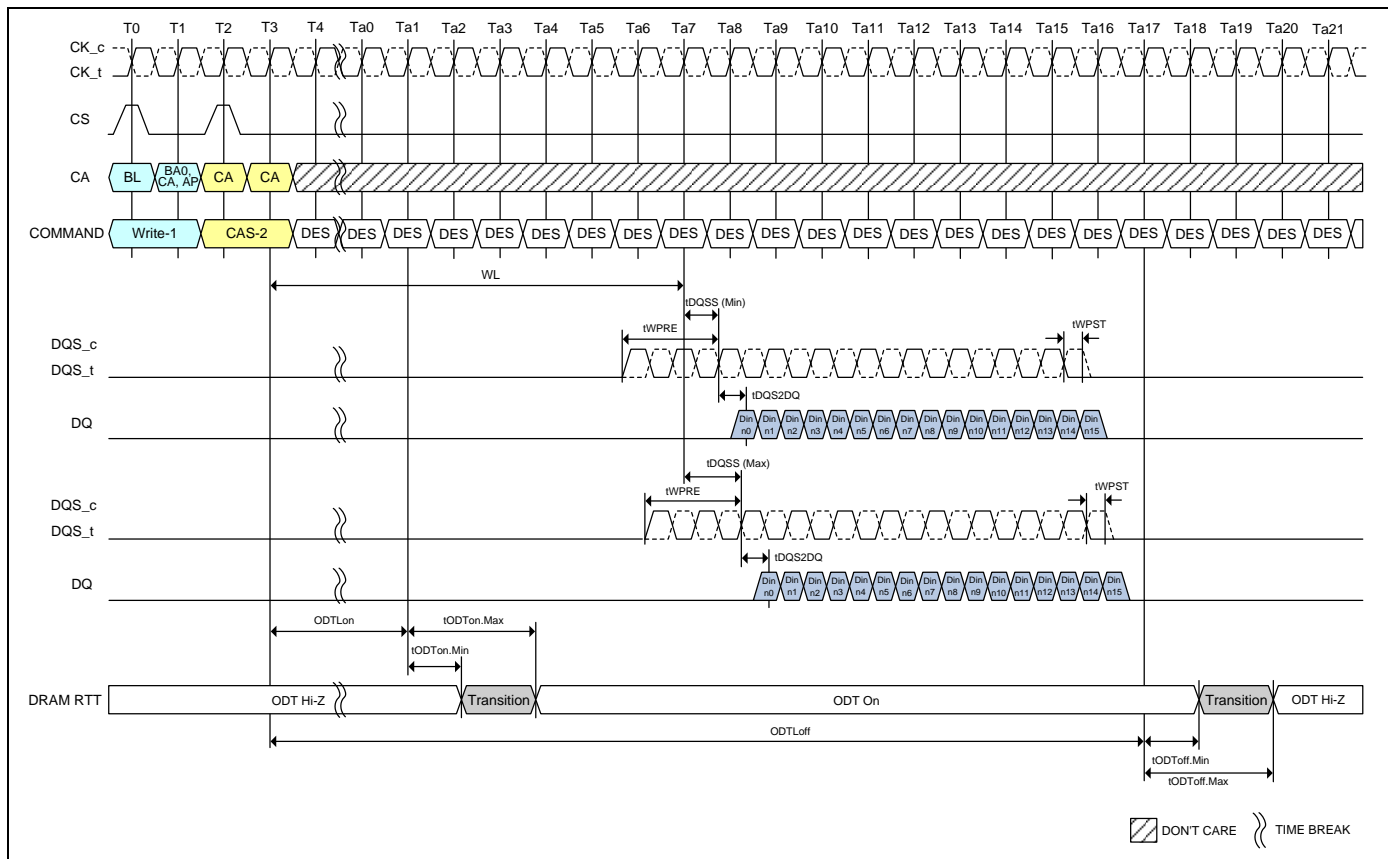

**Notes:**

1. BL=16, Write Postamble = 0.5nCK, DQ/DQS: VSSQ termination.
2. Din n = data-in to column n.
3. DES commands are shown for ease of illustration; other commands may be valid at these times.

**Figure 131 - Asynchronous ODTon/ODTOff Timing**

**7.4.41.3 ODT during Write Leveling**

If ODT is enabled in MR11 OP[3:0], in Write Leveling mode, DRAM always provides the termination on DQS\_t/DQS\_c signals. DQ termination is always off in Write Leveling mode regardless.

**Table 81 - DRAM Termination Function in Write Leveling Mode**

ODT Enabled in MR11	DQS_t/DQS_c termination	DQ termination
Disabled	OFF	OFF
Enabled	ON	OFF



#### 7.4.42 On Die Termination for DQ, DQS and DMI

On-Die Termination effective resistance  $R_{TT}$  is defined by MR11 OP[2:0].

ODT is applied to the DQ, DMI, DQS\_t and DQS\_c pins.

A functional representation of the on-die termination is shown in Figure 132.

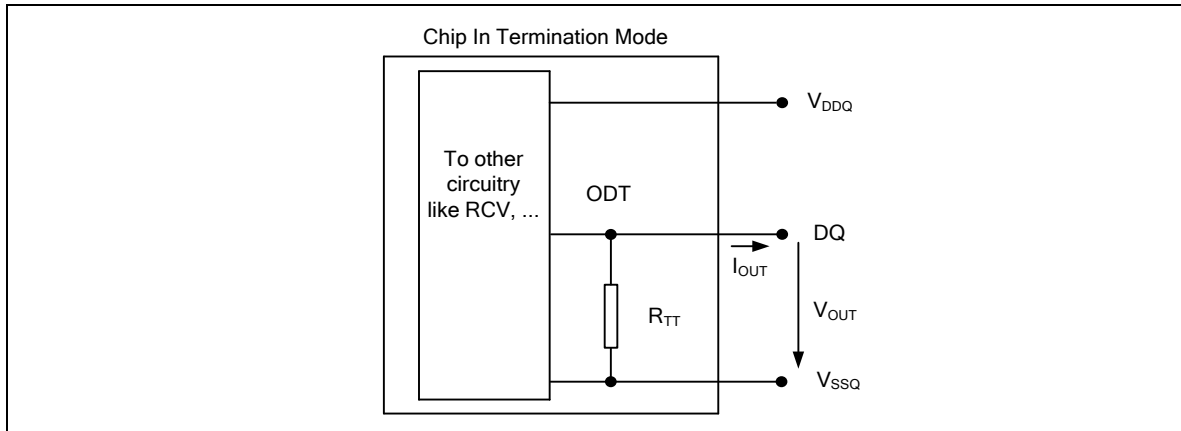

Figure 132 - On Die Termination

$$R_{TT} = \frac{V_{out}}{|I_{out}|}$$

**Table 82 - ODT DC Electrical Characteristics**

(Assuming RZQ = 240 Ω ±1% over the entire operating temperature range after a proper ZQ calibration)

MR11[2:0]	RTT	Vout	Min	Nom	Max	Unit	Notes
001	240 Ω	VOLdc= 0.20 * VDDQ	0.8	1.0	1.1	RZQ	1, 2
		VOMdc= 0.50 * VDDQ	0.9	1.0	1.1	RZQ	1, 2
		VOHdc= 0.75 * VDDQ	0.9	1.0	1.3	RZQ	1, 2
010	120 Ω	VOLdc= 0.20 * VDDQ	0.8	1.0	1.1	RZQ/2	1, 2
		VOMdc= 0.50 * VDDQ	0.9	1.0	1.1	RZQ/2	1, 2
		VOHdc= 0.75 * VDDQ	0.9	1.0	1.3	RZQ/2	1, 2
011	80 Ω	VOLdc= 0.20 * VDDQ	0.8	1.0	1.1	RZQ/3	1, 2
		VOMdc= 0.50 * VDDQ	0.9	1.0	1.1	RZQ/3	1, 2
		VOHdc= 0.75 * VDDQ	0.9	1.0	1.3	RZQ/3	1, 2
100	60 Ω	VOLdc= 0.20 * VDDQ	0.8	1.0	1.1	RZQ/4	1, 2
		VOMdc= 0.50 * VDDQ	0.9	1.0	1.1	RZQ/4	1, 2
		VOHdc= 0.75 * VDDQ	0.9	1.0	1.3	RZQ/4	1, 2
101	48 Ω	VOLdc= 0.20 * VDDQ	0.8	1.0	1.1	RZQ/5	1, 2
		VOMdc= 0.50 * VDDQ	0.9	1.0	1.1	RZQ/5	1, 2
		VOHdc= 0.75 * VDDQ	0.9	1.0	1.3	RZQ/5	1, 2
110	40 Ω	VOLdc= 0.20 * VDDQ	0.8	1.0	1.1	RZQ/6	1, 2
		VOMdc= 0.50 * VDDQ	0.9	1.0	1.1	RZQ/6	1, 2
		VOHdc= 0.75 * VDDQ	0.9	1.0	1.3	RZQ/6	1, 2
Mismatch DQ-DQ within byte		0.50 * VDDQ	-		2	%	1, 2, 3

**Notes:**

1. The tolerance limits are specified after calibration with stable voltage and temperature. For the behavior of the tolerance limits if temperature or voltage changes after calibration, see following section on voltage and temperature sensitivity.
2. Pull-down ODT resistors are recommended to be calibrated at 0.75\*VDDQ and 0.2\*VDDQ. Other calibration schemes may be used to achieve the linearity spec shown above, e.g., calibration at 0.75\*VDDQ and 0.1\*VDDQ.
3. DQ to DQ mismatch within byte variation for a given component including DQS\_t and DQS\_c (characterized).

$$\text{DQ - DQ Mismatch} = \frac{\text{RODT(max)} - \text{RODT(min)}}{\text{RODT(avg)}}$$





#### 7.4.43 Output Driver and Termination Register Temperature and Voltage Sensitivity

If temperature and/or voltage change after calibration, the tolerance limits widen according to Table 83 and Table 84.

**Table 83 - Output Driver and Termination Register Sensitivity Definition**

Resistor	Definition Point	Min	Max	Unit	Notes
R <sub>ONPD</sub>	0.50 x VDDQ	90-(dR <sub>on</sub> dT x  ΔT )-(dR <sub>on</sub> dV x  ΔV )	110+(dR <sub>on</sub> dT x  ΔT )+(dR <sub>on</sub> dV x  ΔV )	%	1,2
VOH <sub>PU</sub>	0.50 x VDDQ	90-(dVOHdT x  ΔT )-(dVOHdV x  ΔV )	110+(dVOHdT x  ΔT )+(dVOHdV x  ΔV )	%	1,2,5
R <sub>TT(I/O)</sub>	0.50 x VDDQ	90-(dR <sub>on</sub> dT x  ΔT )-(dR <sub>on</sub> dV x  ΔV )	110+(dR <sub>on</sub> dT x  ΔT )+(dR <sub>on</sub> dV x  ΔV )	%	1,2,3
R <sub>TT(In)</sub>	0.50 x VDDQ	90-(dR <sub>on</sub> dT x  ΔT )-(dR <sub>on</sub> dV x  ΔV )	110+(dR <sub>on</sub> dT x  ΔT )+(dR <sub>on</sub> dV x  ΔV )	%	1,2,4

**Notes:**

1.  $\Delta T = T - T(@ \text{ Calibration})$ ,  $\Delta V = V - V(@ \text{ Calibration})$ .
2. dR<sub>ON</sub>dT, dR<sub>ON</sub>dV, dVOHdT, dVOHdV, dR<sub>TT</sub>dV, and dR<sub>TT</sub>dT are not subject to production test but are verified by design and characterization.
3. This parameter applies to Input/Output pin such as DQS, DQ and DMI.
4. This parameter applies to Input pin such as CK, CA and CS.
5. Refer to 7.4.39 Pull Up/Pull Down Driver Characteristics for VOH<sub>PU</sub>.

**Table 84 - Output Driver and Termination Register Temperature and Voltage Sensitivity**

Symbol	Parameter	Min	Max	Unit
dR <sub>ON</sub> dT	R <sub>ON</sub> Temperature Sensitivity	0.00	0.75	%/°C
dR <sub>ON</sub> dV	R <sub>ON</sub> Voltage Sensitivity	0.00	0.20	%/mV
dVOHdT	VOH Temperature Sensitivity	0.00	0.75	%/°C
dVOHdV	VOH Voltage Sensitivity	0.00	0.35	%/mV
dR <sub>TT</sub> dT	R <sub>TT</sub> Temperature Sensitivity	0.00	0.75	%/°C
dR <sub>TT</sub> dV	R <sub>TT</sub> Voltage Sensitivity	0.00	0.20	%/mV



## 7.4.44 Power-Down Mode

### 7.4.44.1 Power-Down Entry and Exit

Power-down is asynchronously entered when CKE is driven LOW. CKE must not go LOW while the following operations are in progress:

- Mode Register Read
- Mode Register Write
- Read
- Write
- VREF(CA) Range and Value setting via MRW
- VREF(DQ) Range and Value setting via MRW
- Command Bus Training mode Entering/Exiting via MRW
- VRCG High Current mode Entering/Exiting via MRW

And the LPDDR4X DRAM cannot be placed in power-down state during “Start DQS Interval Oscillator” operation.

CKE can go LOW while any other operations such as row activation, Precharge, Auto-Precharge, or Refresh are in progress. The power-down IDD specification will not be applied until such operations are complete. Power-down entry and exit are shown in Figure 133.

Entering power-down deactivates the input and output buffers, excluding CKE and Reset\_n. To ensure that there is enough time to account for internal delay on the CKE signal path, CS input is required stable Low level and CA input level is don't care after CKE is driven LOW, this timing period is defined as tCKELCS.

Clock input is required after CKE is driven LOW, this timing period is defined as tCKELCK. CKE LOW will result in deactivation of all input receivers except Reset\_n after tCKELCK has expired. In power-down mode, CKE must be held LOW; all other input signals except Reset\_n are "Don't Care". CKE LOW must be maintained until tCKE,min is satisfied.

No refresh operations are performed in power-down mode except Self Refresh power-down. The maximum duration in non-Self Refresh power-down mode is only limited by the refresh requirements outlined in the Refresh command section.

The power-down state is asynchronously exited when CKE is driven HIGH. CKE HIGH must be maintained until tCKE,min is satisfied. A valid, executable command can be applied with power-down exit latency tXP after CKE goes HIGH. Power-down exit latency is defined in the AC timing parameter table.

Clock frequency change or Clock Stop is inhibited during tCMDCKE, tCKELCK, tCKCKEH, tXP, tMRWCKEL and tZQCKE periods.

If power-down occurs when all banks are idle, this mode is referred to as idle power-down. If power-down occurs when there is a row active in any bank, this mode is referred to as active power-down. And if power-down occurs when Self Refresh is in progress, this mode is referred to as Self Refresh power-down in which the internal refresh is continuing in the same way as Self Refresh mode.

VDDQ may be turned off during power-down after tCKELCK(Max(5nS,5nCK)) is satisfied (Refer to Figure 133 about tCKELCK). Prior to exiting power-down, VDDQ must be within its minimum/maximum operating range.

When CA, CK and/or CS ODT is enabled via MR11 OP[6:4] and also via MR22 or CA-ODT pad setting, the rank providing ODT will continue to terminate the command bus in all DRAM states including power-down when VDDQ is stable and within its minimum/maximum operating range.

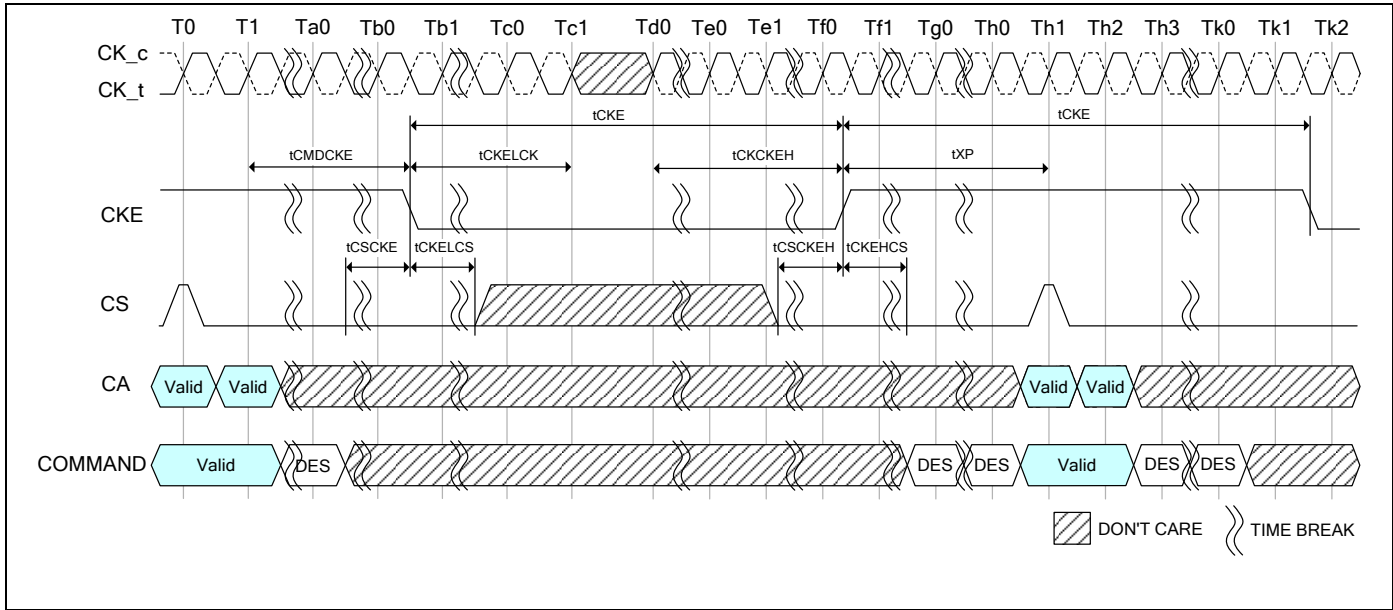

**Note:**

1. Input clock frequency can be changed or the input clock can be stopped or floated during power-down, provided that upon exiting power-down, the clock is stable and within specified limits for a minimum of tCKCKEH of stable clock prior to power-down exit and the clock frequency is between the minimum and maximum specified frequency for the speed grade in use.

**Figure 133 - Basic Power-Down Entry and Exit Timing**

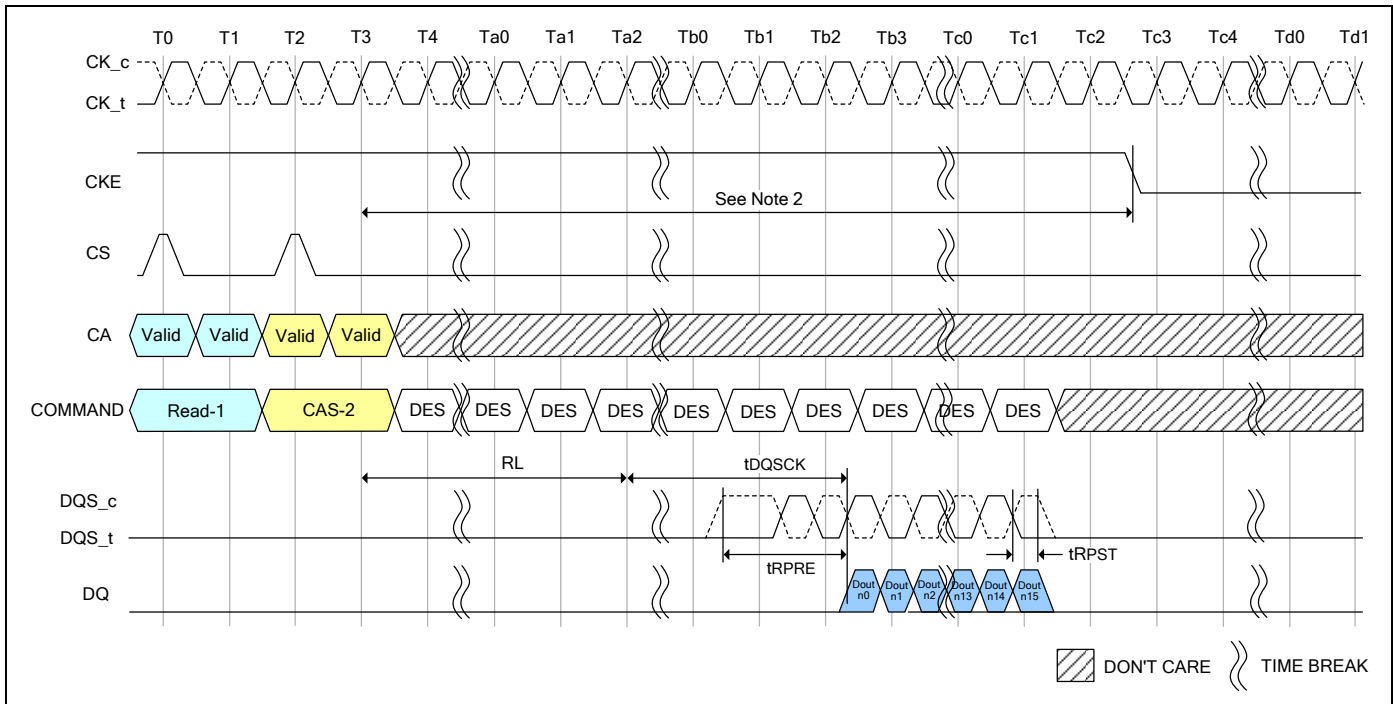

**Notes:**

1. CKE must be held HIGH until the end of the burst operation.
2. Minimum Delay time from Read Command or Read with Auto-Precharge Command to falling edge of CKE signal is as follows.  
 Read Post-amble = 0.5nCK : MR1 OP[7]=[0] :  $(RL \times tCK) + tDQSCK(Max) + ((BL/2) \times tCK) + 1tCK$   
 Read Post-amble = 1.5nCK : MR1 OP[7]=[1] :  $(RL \times tCK) + tDQSCK(Max) + ((BL/2) \times tCK) + 2tCK$

**Figure 134 - Read and Read with Auto-Precharge to Power-Down Entry**

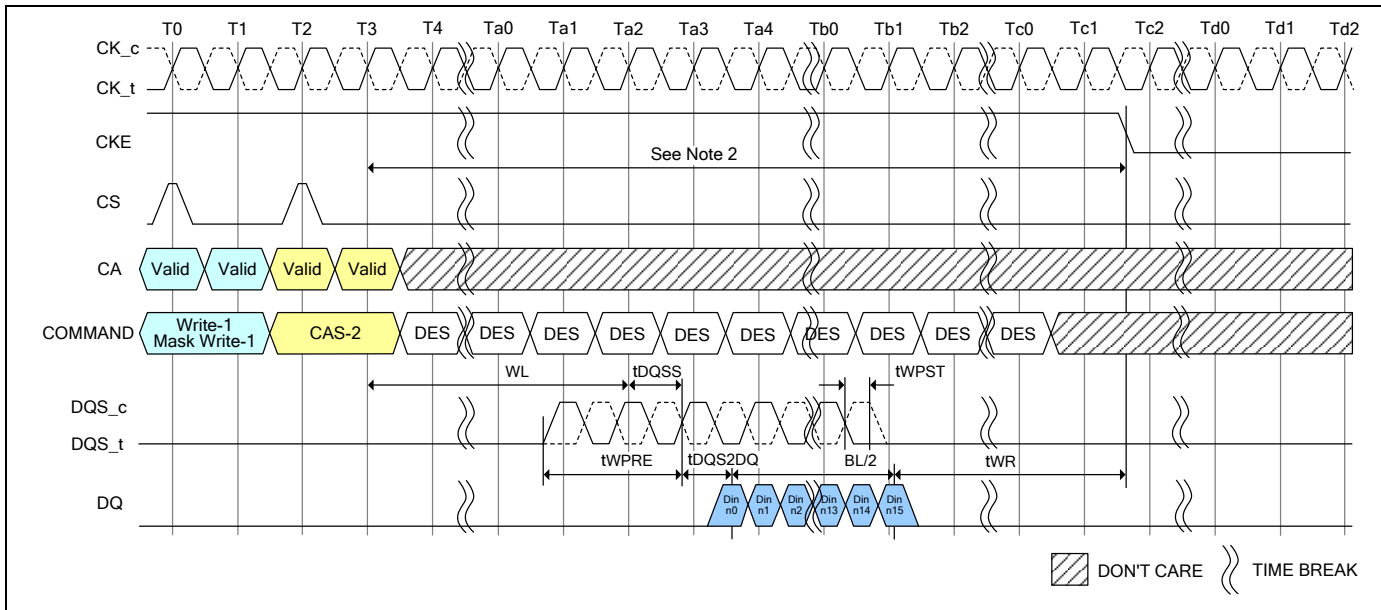

**Notes:**

1. CKE must be held HIGH until the end of the burst operation.
2. Minimum Delay time from Write Command or Mask Write Command to falling edge of CKE signal is as follows.  
 $(WL \times tCK) + tDQSS(Max) + tDQS2DQ(Max) + ((BL/2) \times tCK) + tWR$
3. This timing is applied regardless of DQ ODT Disable/Enable setting: MR11[OP2:0].
4. This timing diagram only applies to the Write and Mask Write Commands without Auto-Precharge.

**Figure 135 - Write and Mask Write to Power-Down Entry**

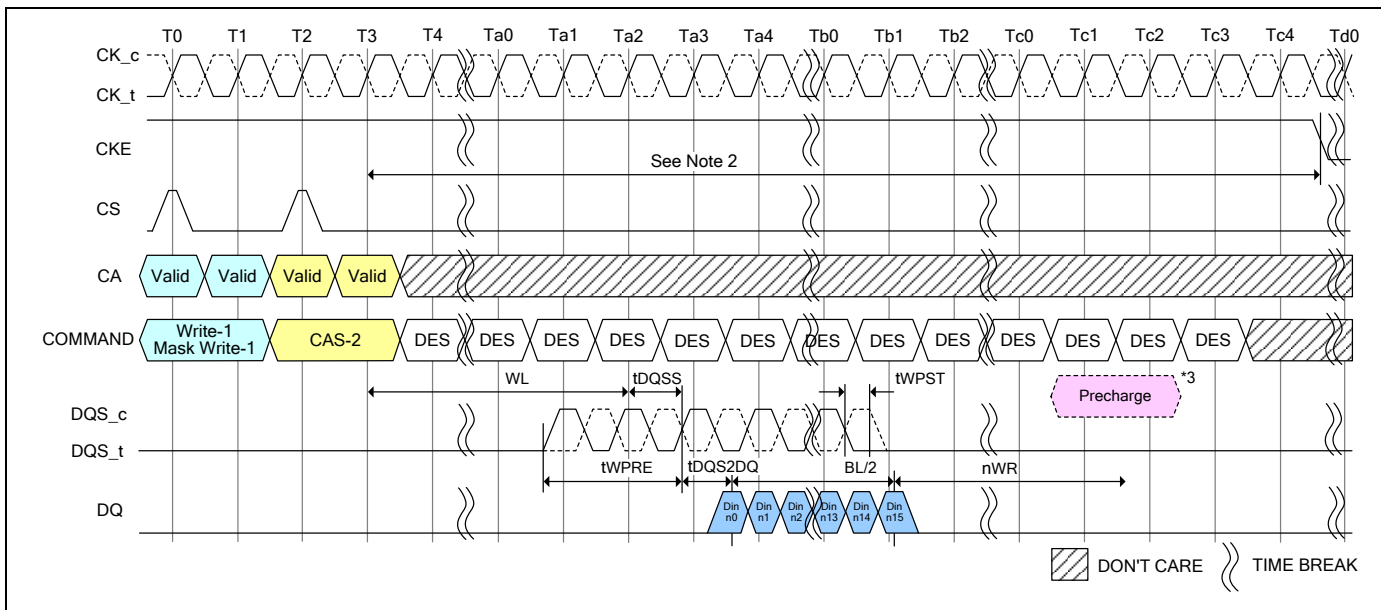

**Notes:**

1. CKE must be held HIGH until the end of the burst operation.
2. Delay time from Write with Auto-Precharge Command or Mask Write with Auto-Precharge Command to falling edge of CKE signal is more than  
 $(WL \times tCK) + tDQSS(Max) + tDQS2DQ(Max) + ((BL/2) \times tCK) + (nWR \times tCK) + (2 \times tCK)$
3. Internal Precharge Command.
4. This timing is applied regardless of DQ ODT Disable/Enable setting: MR11[OP2:0].

**Figure 136 - Write with Auto-Precharge and Mask Write with Auto-Precharge to Power-Down**

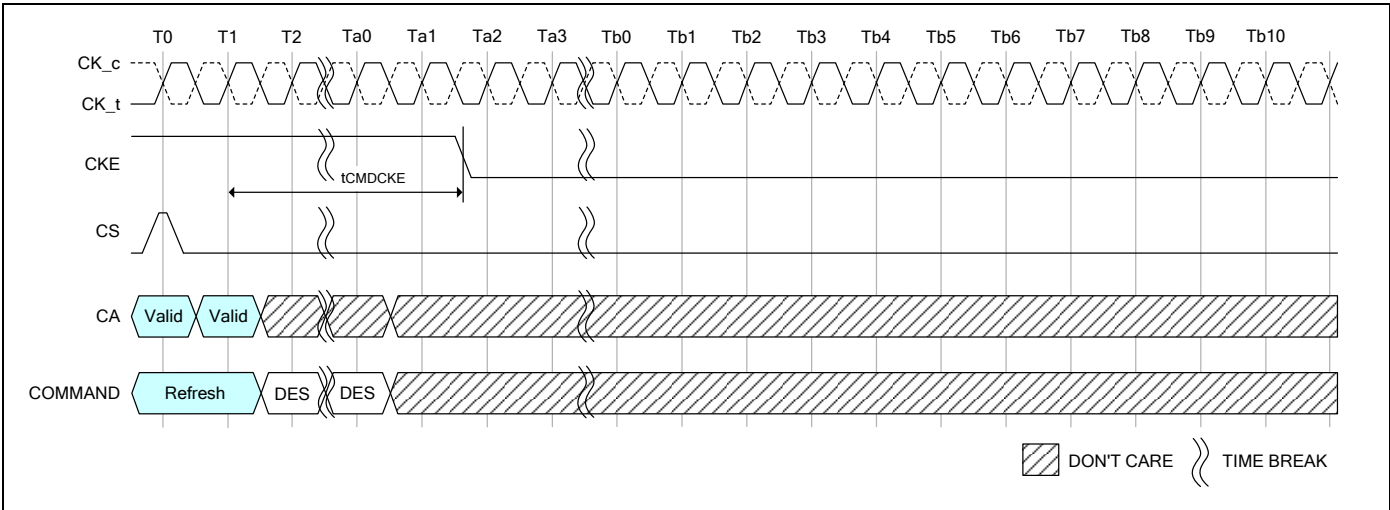

**Note:**

- 1. CKE must be held HIGH until tCMDCKE is satisfied.

**Figure 137 - Refresh entry to Power-Down Entry**

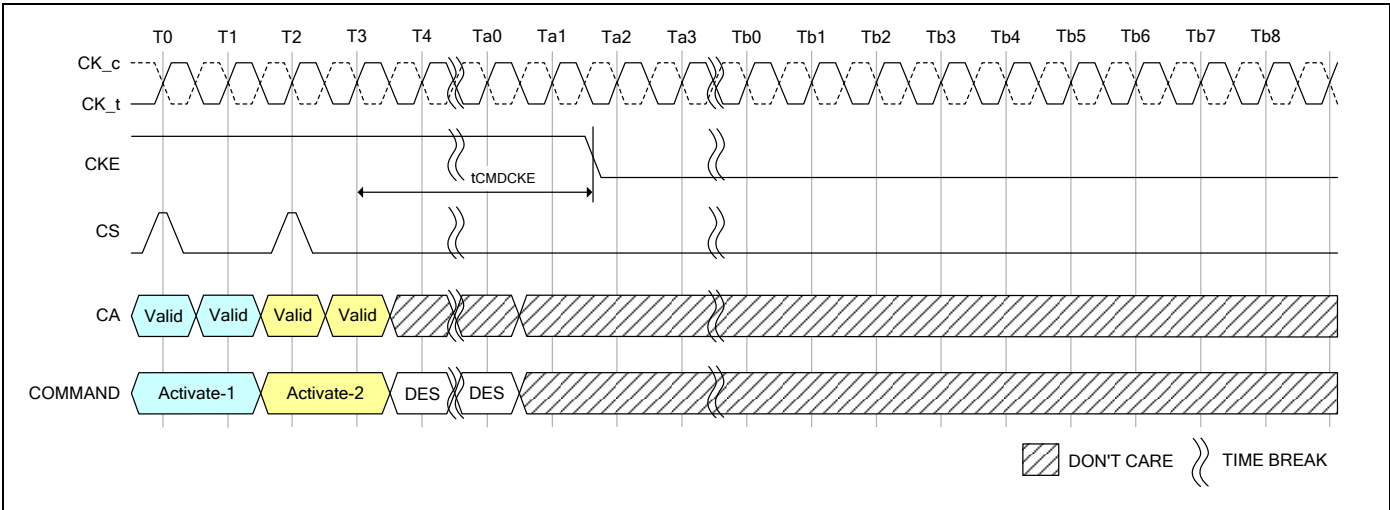

**Note:**

- 1. CKE must be held HIGH until tCMDCKE is satisfied.

**Figure 138 - Activate Command to Power-Down Entry**

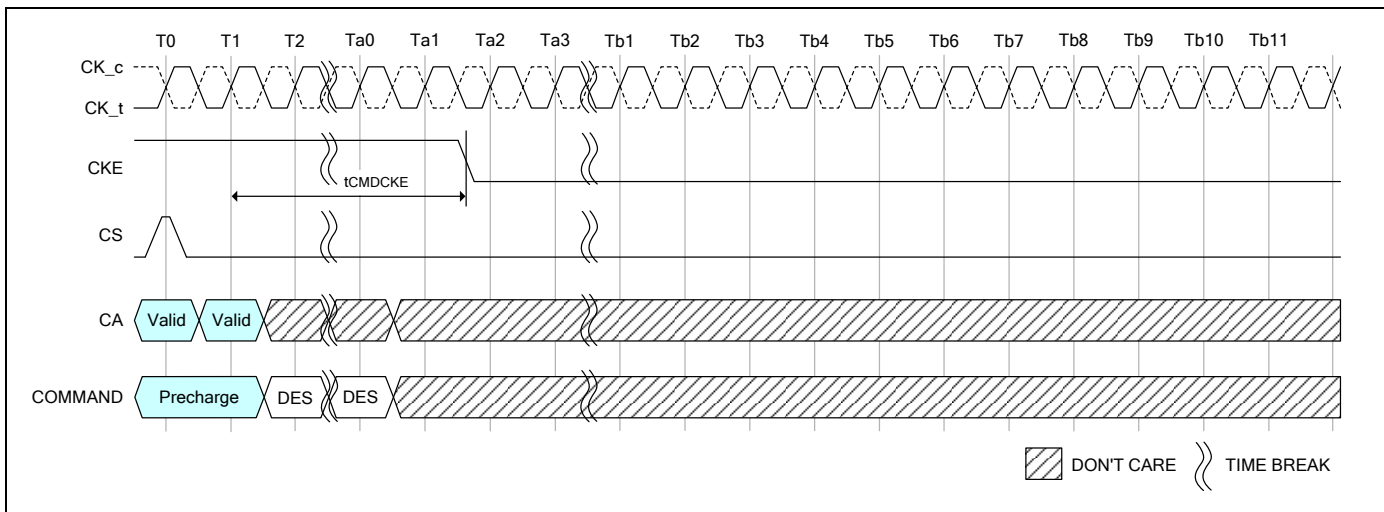

**Note:**

1. CKE must be held HIGH until tCMDCKE is satisfied.

**Figure 139 - Precharge Command to Power-Down Entry**

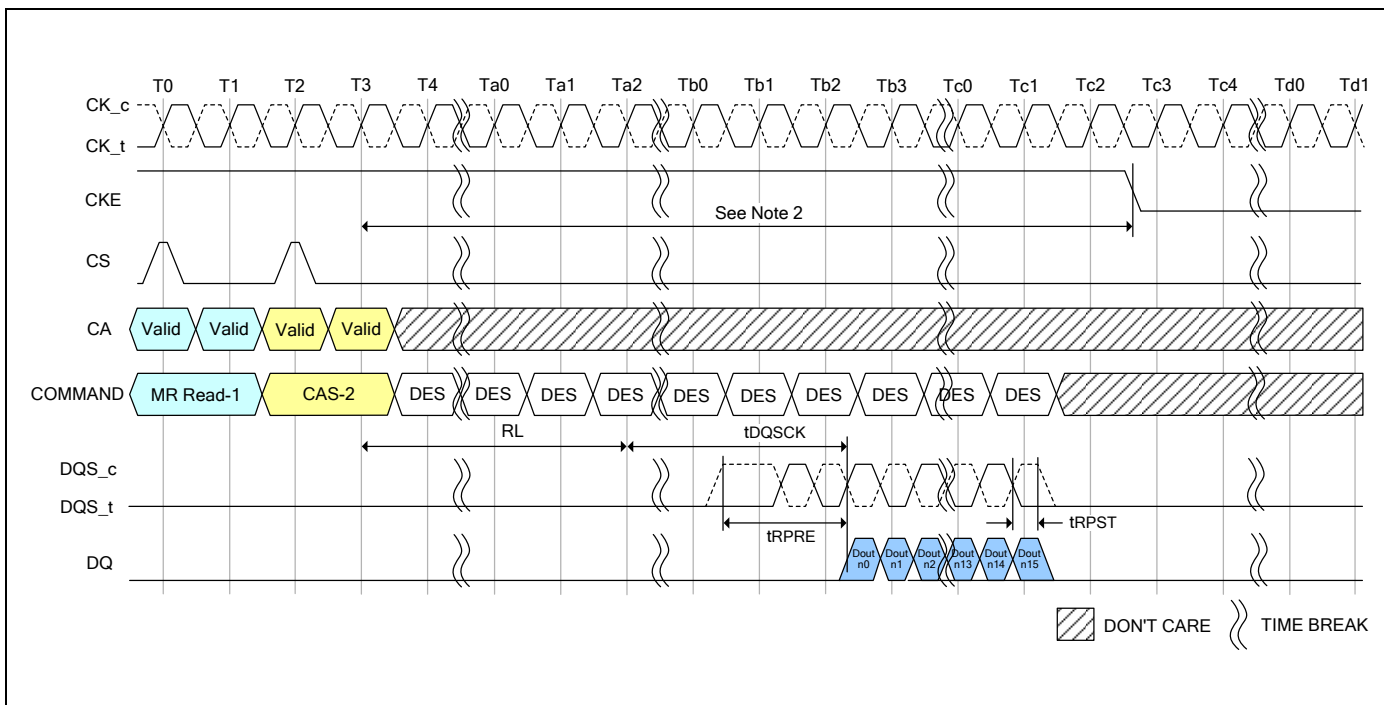

**Notes:**

1. CKE must be held HIGH until the end of the burst operation.
2. Minimum Delay time from Mode Register Read Command to falling edge of CKE signal is as follows:  
 Read Post-amble = 0.5nCK : MR1 OP[7]=[0] :  $(RL \times tCK) + tDQSCK(Max) + ((BL/2) \times tCK) + 1tCK$   
 Read Post-amble = 1.5nCK : MR1 OP[7]=[1] :  $(RL \times tCK) + tDQSCK(Max) + ((BL/2) \times tCK) + 2tCK$

**Figure 140 - Mode Register Read to Power-Down Entry**

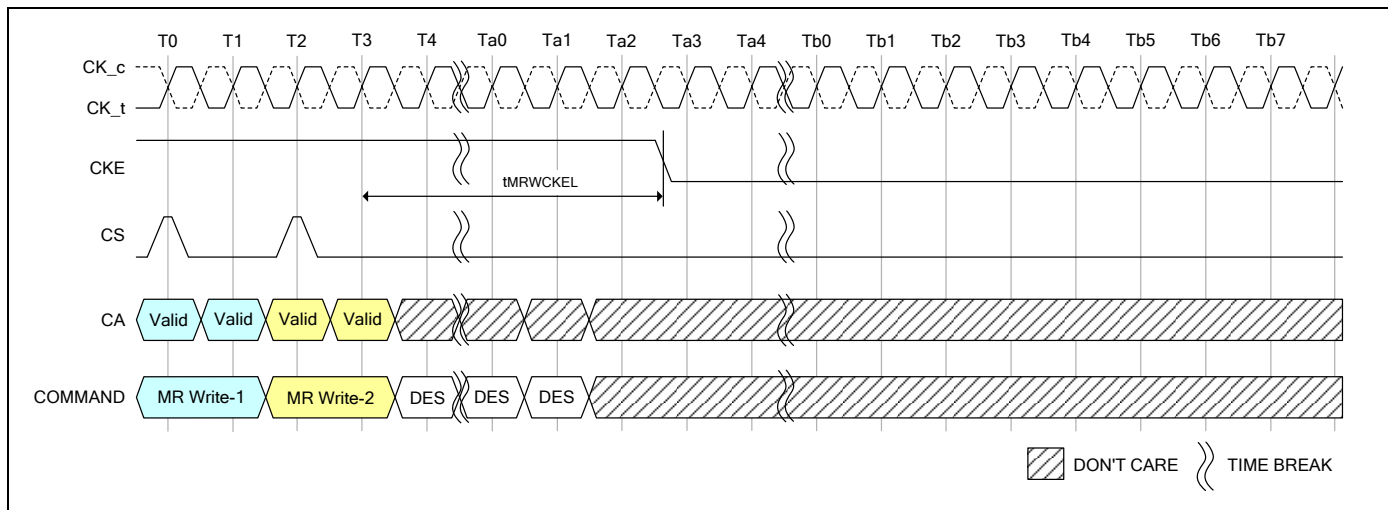

**Notes:**

1. CKE must be held HIGH until tMRWCKEL is satisfied.
2. This timing is the general definition for Power Down Entry after Mode Register Write Command.  
 When a Mode Register Write Command changes a parameter or starts an operation that requires special timing longer than tMRWCKEL, that timing must be satisfied before CKE is driven low.  
 Changing the VREF(DQ) value is one example, in this case the appropriate VREF\_time-Short/Middle/Long must be satisfied.

**Figure 141 - Mode Register Write to Power-Down Entry**

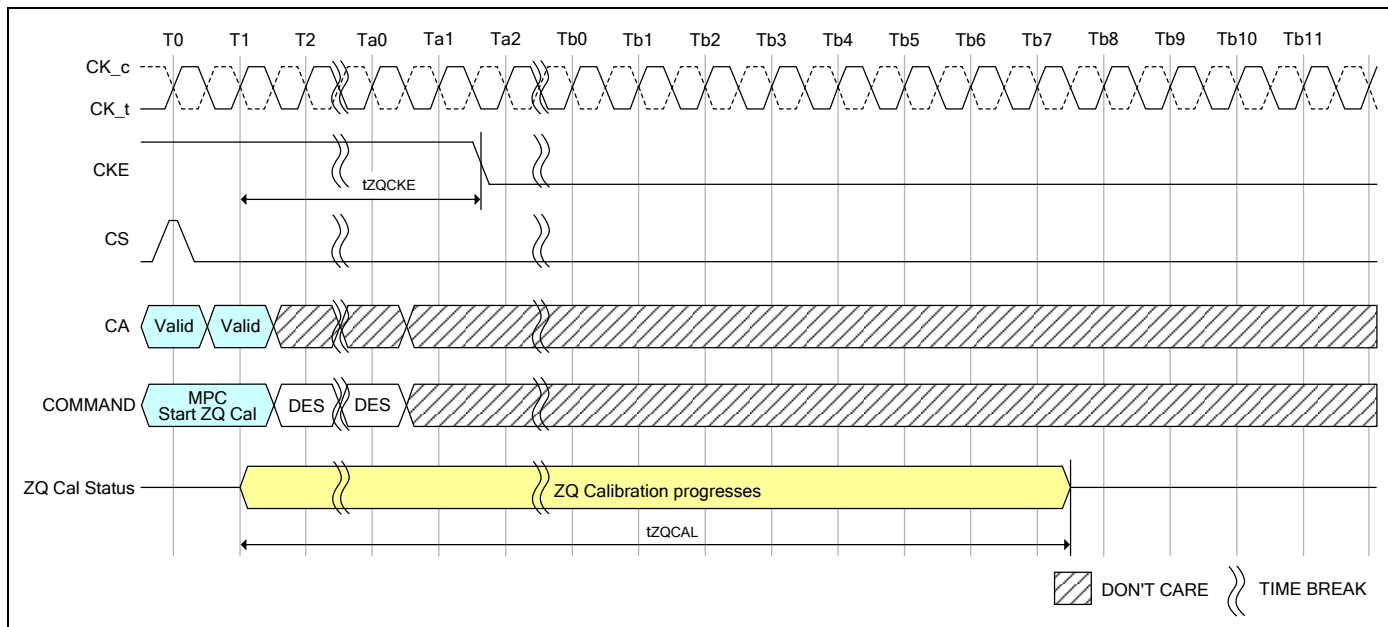

**Note:**

1. ZQ Calibration continues if CKE goes low after tZQCKE is satisfied.

**Figure 142 - Multi-Purpose Command for Start ZQ Calibration to Power-Down Entry**





Table 85 - Power-Down AC Timing

Parameter	Symbol	Min/ Max	Data Rate	Unit	Note
Power Down Timing					
CKE minimum pulse width (HIGH and LOW pulse width)	tCKE	Min	Max(7.5nS, 4nCK)	-	
Delay from valid command to CKE input LOW	tCMDCKE	Min	Max(1.75nS, 3nCK)	nS	1
Valid Clock Requirement after CKE Input low	tCKELCK	Min	Max(5nS, 5nCK)	nS	1
Valid CS Requirement before CKE Input Low	tCSCKE	Min	1.75	nS	
Valid CS Requirement after CKE Input low	tCKELCS	Min	Max(5nS, 5nCK)	nS	
Valid Clock Requirement before CKE Input High	tCKCKEH	Min	Max(1.75nS, 3nCK)	nS	1
Exit power- down to next valid command delay	tXP	Min	Max(7.5nS, 5nCK)	nS	1
Valid CS Requirement before CKE Input High	tCSCKEH	Min	1.75	nS	
Valid CS Requirement after CKE Input High	tCKEHCS	Min	Max(7.5nS, 5nCK)	nS	
Valid Clock and CS Requirement after CKE Input low after MRW Command	tMRWCKEL	Min	Max(14nS, 10nCK)	nS	1
Valid Clock and CS Requirement after CKE Input low after ZQ Calibration Start Command	tZQCKE	Min	Max(1.75nS, 3nCK)	nS	1

**Note:**

1. Delay time has to satisfy both analog time (nS) and clock count (nCK).

For example, tCMDCKE will not expire until CK has toggled through at least 3 full cycles (3 \*tCK) and 1.75nS has transpired. The case which 3nCK is applied to is shown In Figure 143.

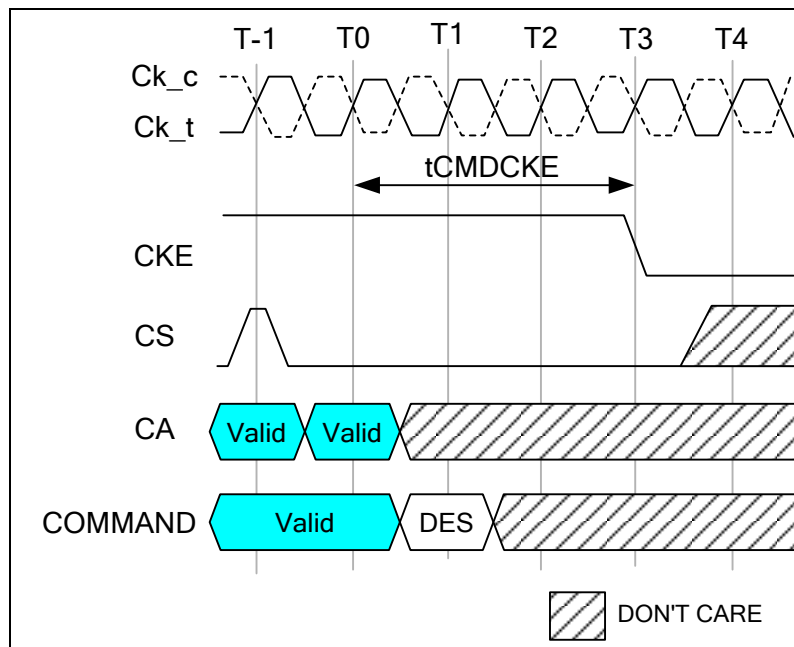

Figure 143 - tCMDCKE Timing





#### 7.4.45 Input Clock Stop and Frequency Change

LPDDR4X SDRAMs support input clock frequency change during CKE LOW under the following conditions:

- tCK(abs)min is met for each clock cycle;
- Refresh requirements apply during clock frequency change;
- During clock frequency change, only REFAb or REFpb commands may be executing;
- Any Activate or Precharge commands have executed to completion prior to changing the frequency;
- The related timing conditions (tRCD, tRP) have been met prior to changing the frequency;
- The initial clock frequency shall be maintained for a minimum of tCKELCK after CKE goes LOW;
- The clock satisfies tCH(abs) and tCL(abs) for a minimum of tCKCKEH prior to CKE going HIGH

After the input clock frequency is changed and CKE is held HIGH, additional MRW commands may be required to set the WR, RL etc. These settings may need to be adjusted to meet minimum timing requirements at the target clock frequency.

LPDDR4X devices support clock stop during CKE LOW under the following conditions:

- CK\_t and CK\_c are don't care during clock stop;
- Refresh requirements apply during clock stop;
- During clock stop, only REFAb or REFpb commands may be executing;
- Any Activate or Precharge commands have executed to completion prior to stopping the clock;
- The related timing conditions (tRCD, tRP) have been met prior to stopping the clock;
- The initial clock frequency shall be maintained for a minimum of tCKELCK after CKE goes LOW;
- The clock satisfies tCH(abs) and tCL(abs) for a minimum of tCKCKEH prior to CKE going HIGH

LPDDR4X devices support input clock frequency change during CKE HIGH under the following conditions:

- tCK(abs)min is met for each clock cycle;
- Refresh requirements apply during clock frequency change;
- Any Activate, Read, Write, Precharge, Mode Register Write, or Mode Register Read commands must have executed to completion, including any associated data bursts prior to changing the frequency;
- The related timing conditions (tRCD, tWR, tWRA, tRP, tMRW, tMRR, etc.) have been met prior to changing the frequency;
- CS shall be held LOW during clock frequency change;
- During clock frequency change, only REFAb or REFpb commands may be executing;
- The LPDDR4X SDRAM is ready for normal operation after the clock satisfies tCH(abs) and tCL(abs) for a minimum of  $2 \cdot tCK + tXP$ .

After the input clock frequency is changed, additional MRW commands may be required to set the WR, RL etc. These settings may need to be adjusted to meet minimum timing requirements at the target clock frequency.



LPDDR4X devices support clock stop during CKE HIGH under the following conditions:

- CK\_t is held LOW and CK\_c is held HIGH during clock stop;
- CS shall be held LOW during clock stop;
- Refresh requirements apply during clock stop;
- During clock stop, only REFab or REFpb commands may be executing;
- Any Activate, Read, Write, MPC(WRFIFO,RDFIFO,RDDQCAL), Precharge, Mode Register Write or Mode Register Read commands must have executed to completion, including any associated data bursts and extra 4 clock cycles must be provided prior to stopping the clock;
- The related timing conditions (tRCD, tWR, tRP, tMRW, tMRR, tZQLAT, etc.) have been met prior to stopping the clock;
- Read with auto precharge and write with auto precharge commands need extra 4 clock cycles in addition to the related timing constraints, nWR and nRTP, to complete the operations.
- REFab, REFpb, SRE, SRX and MPC(Zqcal Start) commands are required to have 4 additional clocks prior to stopping the clock same as CKE=L case.
- The LPDDR4X SDRAM is ready for normal operation after the clock is restarted and satisfies tCH(abs) and tCL(abs) for a minimum of  $2 \cdot tCK + tXP$ .



#### 7.4.46 Truth Tables

Operation or timing that is not specified is illegal, and after such an event, in order to guarantee proper operation, the LPDDR4X device must be reset or power-cycled and then restarted through the specified initialization sequence before normal operation can continue.

CKE signal has to be held HIGH when the commands listed in Table 86 inputs.

**Table 86 - Command Truth Table**

SDRAM Command	SDR Command Pins	SDR CA Pins (6)						CK_t edge	Notes
	CS	CA0	CA1	CA2	CA3	CA4	CA5		
Deselect (DES)	L	X						R1	1,2
Multi-Purpose Command (MPC)	H	L	L	L	L	L	OP6	R1	1,9
	L	OP0	OP1	OP2	OP3	OP4	OP5	R2	
Precharge (PRE) (Per Bank, All Bank)	H	L	L	L	L	H	AB	R1	1,2,3,4
	L	BA0	BA1	BA2	V	V	V	R2	
Refresh (REF) (Per Bank, All Bank)	H	L	L	L	H	L	AB	R1	1,2,3,4
	L	BA0	BA1	BA2	V	V	V	R2	
Self Refresh Entry (SRE)	H	L	L	L	H	H	V	R1	1,2
	L	V						R2	
Write -1 (WR-1)	H	L	L	H	L	L	BL	R1	1,2,3,6,7,9
	L	BA0	BA1	BA2	V	C9	AP	R2	
Self Refresh Exit (SRX)	H	L	L	H	L	H	V	R1	1,2
	L	V						R2	
Mask Write -1 (MWR-1)	H	L	L	H	H	L	L	R1	1,2,3,5,6,9
	L	BA0	BA1	BA2	V	C9	AP	R2	
RFU	H	L	L	H	H	H	V	R1	1,2
	L	V						R2	
Read -1 (RD-1)	H	L	H	L	L	L	BL	R1	1,2,3,6,7,9
	L	BA0	BA1	BA2	V	C9	AP	R2	
CAS-2 (Write-2, Mask Write -2, Read-2, MRR-2, MPC)	H	L	H	L	L	H	C8	R1	1,8,9
	L	C2	C3	C4	C5	C6	C7	R2	
RFU	H	L	H	L	H	L	V	R1	1,2
	L	V						R2	
RFU	H	L	H	L	H	H	V	R1	1,2
	L	V						R2	
Mode Register Write-1 (MRW-1)	H	L	H	H	L	L	OP7	R1	1,11
	L	MA0	MA1	MA2	MA3	MA4	MA5	R2	
Mode Register Write-2 (MRW-2)	H	L	H	H	L	H	OP6	R1	1,11
	L	OP0	OP1	OP2	OP3	OP4	OP5	R2	
Mode Register Read-1 (MRR-1)	H	L	H	H	H	L	V	R1	1,2,12
	L	MA0	MA1	MA2	MA3	MA4	MA5	R2	
RFU	H	L	H	H	H	H	V	R1	1,2
	L	V						R2	
Activate-1 (ACT-1)	H	H	L	R12	R13	X	X	R1	1,2,3,10
	L	BA0	BA1	BA2	X	R10	R11	R2	
Activate-2 (ACT-2)	H	H	H	R6	R7	R8	R9	R1	1,10
	L	R0	R1	R2	R3	R4	R5	R2	

**Notes:**

1. All LPDDR4X commands except for Deselect are 2 clock cycle long and defined by states of CS and CA[5:0] at the first rising edge of clock. Deselect command is 1 clock cycle long.
2. "V" means "H" or "L" (a defined logic level). "X" means don't care in which case CA[5:0] can be floated.
3. Bank addresses BA[2:0] determine which bank is to be operated upon.
4. AB "HIGH" during Precharge or Refresh command indicates that command must be applied to all banks and bank address are don't care.
5. Mask Write-1 command supports only BL 16. For Mark Write-1 command, CA5 must be driven LOW on first rising clock cycle (R1).
6. AP "HIGH" during Write-1, Mask Write-1 or Read-1 commands indicates that an Auto-Precharge will occur to the bank associated with the Write, Mask Write or Read command.
7. If Burst Length on-the-fly is enabled, BL "HIGH" during Write-1 or Read-1 command indicates that Burst Length should be set on-the-fly to BL=32. BL "LOW" during Write-1 or Read-1 command indicates that Burst Length should be set on-the-fly to BL=16. If Burst Length on-the-fly is disabled, then BL must be driven to defined logic level "H" or "L".
8. For CAS-2 commands (Write-2 or Mask Write-2 or Read-2 or MRR-2 or MPC (Only Write FIFO, Read FIFO & Read DQ Calibration), C[1:0] are not transmitted on the CA[5:0] bus and are assumed to be zero. Note that for CAS-2 Write-2 or CAS-2 Mask Write-2 command, C[3:2] must be driven LOW.
9. Write-1 or Mask Write-1 or Read-1 or Mode Register Read-1 or MPC (Only Write FIFO, Read FIFO & Read DQ Calibration) command must be immediately followed by CAS-2 command consecutively without any other command in between. Write-1 or Mask Write-1 or Read-1 or Mode Register Read-1 or MPC (Only Write FIFO, Read FIFO & Read DQ Calibration) command must be issued first before issuing CAS-2 command. MPC (Only Start & Stop DQS Oscillator, Start & Latch ZQ Calibration) commands do not require CAS-2 command; they require two additional DES or NOP commands consecutively before issuing any other commands.
10. Activate-1 command must be immediately followed by Activate-2 command consecutively without any other command in between. Activate-1 command must be issued first before issuing Activate-2 command. Once
11. MRW-1 command must be immediately followed by MRW-2 command consecutively without any other command in between. MRW-1 command must be issued first before issuing MRW-2 command.
12. MRR-1 command must be immediately followed by CAS-2 command consecutively without any other command in between. MRR-1 command must be issued first before issuing CAS-2 command.



#### 7.4.47 TRR Mode - Target Row Refresh

A LPDDR4X SDRAM's row has a limited number of times a given row can be accessed within a refresh period ( $t_{REFW} * 2$ ) prior to requiring adjacent rows to be refreshed. The Maximum Activate Count (MAC) is the maximum number of activates that a single row can sustain within a refresh period before the adjacent rows need to be refreshed. The row receiving the excessive activates is the Target Row ( $TR_n$ ), the adjacent rows to be refreshed are the victim rows. When the MAC limit is reached on  $TR_n$ , either the LPDDR4X SDRAM receive all ( $R * 2$ ) Refresh Commands before another row activate is issued, or the LPDDR4X SDRAM should be placed into Targeted Row Refresh (TRR) mode. The TRR Mode will re-refresh the rows adjacent to the  $TR_n$  that encountered tMAC limit.

There could be a maximum of two target rows to a victim row in a bank. The cumulative value of the activation from the two target rows on a victim row in a bank should not exceed MAC value as well. MR24 fields required to support the new TRR settings. Setting MR24 [OP7=1] enables TRR Mode and setting MR24 [OP7=0] disables TRR Mode. MR24 [OP6:OP4] defines which bank (BAn) the target row is located in (See MR24 table for details).

The TRR mode must be disabled during initialization as well as any other LPDDR4X SDRAM calibration modes. The TRR mode is entered from a DRAM Idle State, once TRR mode has been entered, no other Mode Register commands are allowed until TRR mode is completed, except setting MR24 [OP7=0] to interrupt and reissue the TRR mode is allowed.

When enabled; TRR Mode is self-clearing; the mode will be disabled automatically after the completion of defined TRR flow; after the 3rd BAn precharge has completed plus  $t_{MRD}$ . The TRR mode can also be exited via another MRS command at the completion of TRR by setting MR24 [OP7=0]; if the TRR is exited via another MRS command, the value written to MR24 [OP6:OP4] are don't cares.

##### 7.4.47.1 TRR Mode Operation

1. The timing diagram in Figure 148 depicts TRR mode. The following steps must be performed when TRR mode is enabled. This mode requires all three ACT (ACT1, ACT2 and ACT3) and three corresponding PRE commands (PRE1, PRE2 and PRE3) to complete TRR mode. A Precharge All (PREA) commands issued while LPDDR4X SDRAM is in TRR mode will also perform precharge to BAn and counts towards a PREn command.
2. Prior to issuing the MRW command to enter TRR mode, the SDRAM should be in the idle state. A MRW command must be issued with MR24 [OP7=1] and MR24 [OP6:4] defining the bank in which the targeted row is located. All other MR24 bits should remain unchanged.
3. No activity is to occur in the DRAM until  $t_{MRD}$  has been satisfied. Once  $t_{MRD}$  has been satisfied, the only commands to BAn allowed are ACT and PRE until the TRR mode has been completed.
4. The first ACT to the BAn with the  $TR_n$  address can now be applied, no other command is allowed at this point. All other banks must remain inactive from when the first BAn ACT command is issued until  $[(1.5 * t_{RAS}) + t_{RP}]$  is satisfied.
5. After the first ACT to the BAn with the  $TR_n$  address is issued, a PRE to BAn is to be issued ( $1.5 * t_{RAS}$ ) later; and then followed  $t_{RP}$  later by the second ACT to the BAn with the  $TR_n$  address. Once the 2nd activate to the BAn is issued, non BAn banks are allowed to have activity.
6. After the second ACT to the BAn with the  $TR_n$  address is issued, a PRE to BAn is to be issued  $t_{RAS}$  later and then followed  $t_{RP}$  later by the third ACT to the BAn with the  $TR_n$  address.
7. After the third ACT to the BAn with the  $TR_n$  address is issued, a PRE to BAn would be issued  $t_{RAS}$  later; and once the third PRE has been issued, non BAn banks are not allowed to have activity until TRR mode is exited. The TRR mode is completed once  $t_{RP}$  plus  $t_{MRD}$  is satisfied.
8. TRR mode must be completed as specified to guarantee that adjacent rows are refreshed. Any-time the TRR mode is interrupted and not completed; the interrupted TRR Mode must be cleared and then subsequently performed again. To clear an interrupted TRR mode, an MR24 change is required with setting MR24 [OP7=0], MR24 [OP6:4] are don't care, followed by three PRE to BAn,  $t_{RP}$  time in between each PRE command. The complete TRR sequence (Steps 2-7) must be then re-issued and completed to guarantee that the adjacent rows are refreshed.
9. Refresh command to the LPDDR4X SDRAM or entering Self Refresh mode is not allowed while the DRAM is in TRR mode.

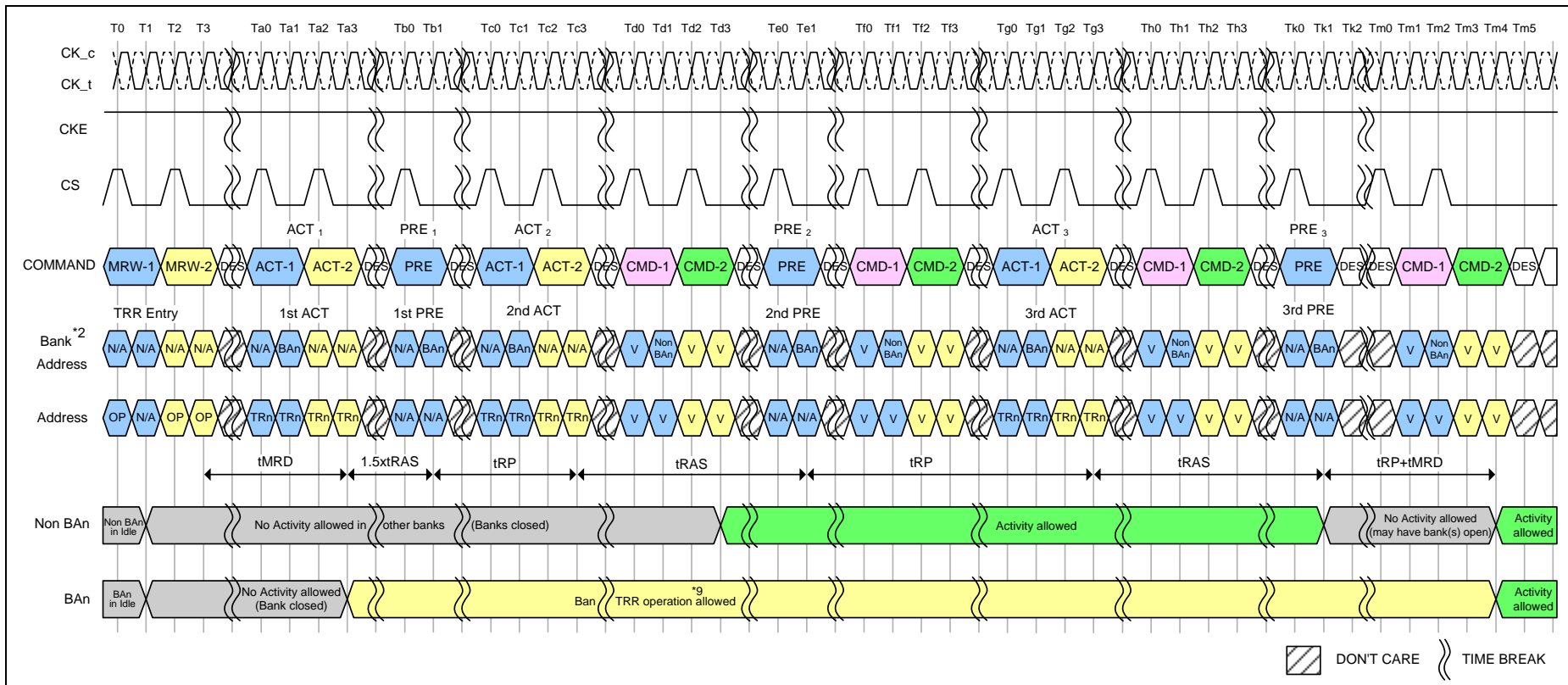

**Notes:**

1. TRn is targeted row.
2. Bank BAn represents the bank in which the targeted row is located.
3. TRR mode self-clears after tMRD + tRP measured from 3rd BAn precharge PRE3 at clock edge Tm4.
4. TRR mode or any other activity can be re-engaged after tRP + tMRD from 3rd BAn precharge PRE3. PRE\_ALL also counts if issued instead of PREn. TRR mode is cleared by DRAM after PRE3 to the BAn bank.
5. Activate commands to BAn during TRR mode do not provide refreshing support, i.e. the Refresh counter is unaffected.
6. The DRAM must restore the degraded row(s) caused by excessive activation of the targeted row (TRn) necessary to meet refresh requirements.
7. A new TRR mode must wait tMRD+tRP time after the third precharge.
8. BAn may not be used with any other command.
9. ACT and PRE are the only allowed commands to BAn during TRR Mode.
10. Refresh commands are not allowed during TRR mode.
11. All DRAM timings are to be met by DRAM during TRR mode such as tFAW. Issuing of ACT1, ACT2 and ACT3 counts towards tFAW budget

**Figure 144 - TRR Mode**





#### 7.4.48 Post Package Repair (PPR)

LPDDR4X supports Fail Row address repair and it is readable through MR25 OP[7:0] PPR provides simple and easy repair method in the system and Fail Row address can be repaired by the electrical programming of Electrical-fuse scheme.

With PPR, LPDDR4X can correct 1Row per Bank.

Electrical-fuse cannot be switched back to un-fused states once it is programmed. The controller should prevent unintended the PPR mode entry and repair.

##### 7.4.48.1 Fail Row Address Repair

The following is procedure of PPR.

1. Before entering 'PPR' mode, All banks must be Precharged.
2. Enable PPR using MR4 bit "OP4=1" and wait tMRD.
3. Issue ACT command with Fail Row address.
4. Wait tPGM to allow DRAM repair target Row Address internally then issue PRE.
5. Wait tPGM\_Exit after PRE which allow DRAM to recognize repaired Row address RAn.
6. Exit PPR with setting MR4 bit "OP4=0".
7. Issue RESET command after tPGMPST.
8. Repeat steps in '7.2.2 Reset Initialization with Stable Power' section.
9. In more than one fail address repair case, Repeat Step 2 to 8.

Once PPR mode is exited, to confirm if target row is repaired correctly, host can verify by writing data into the target row and reading it back after PPR exit with MR4 [OP4=0] and tPGMPST.

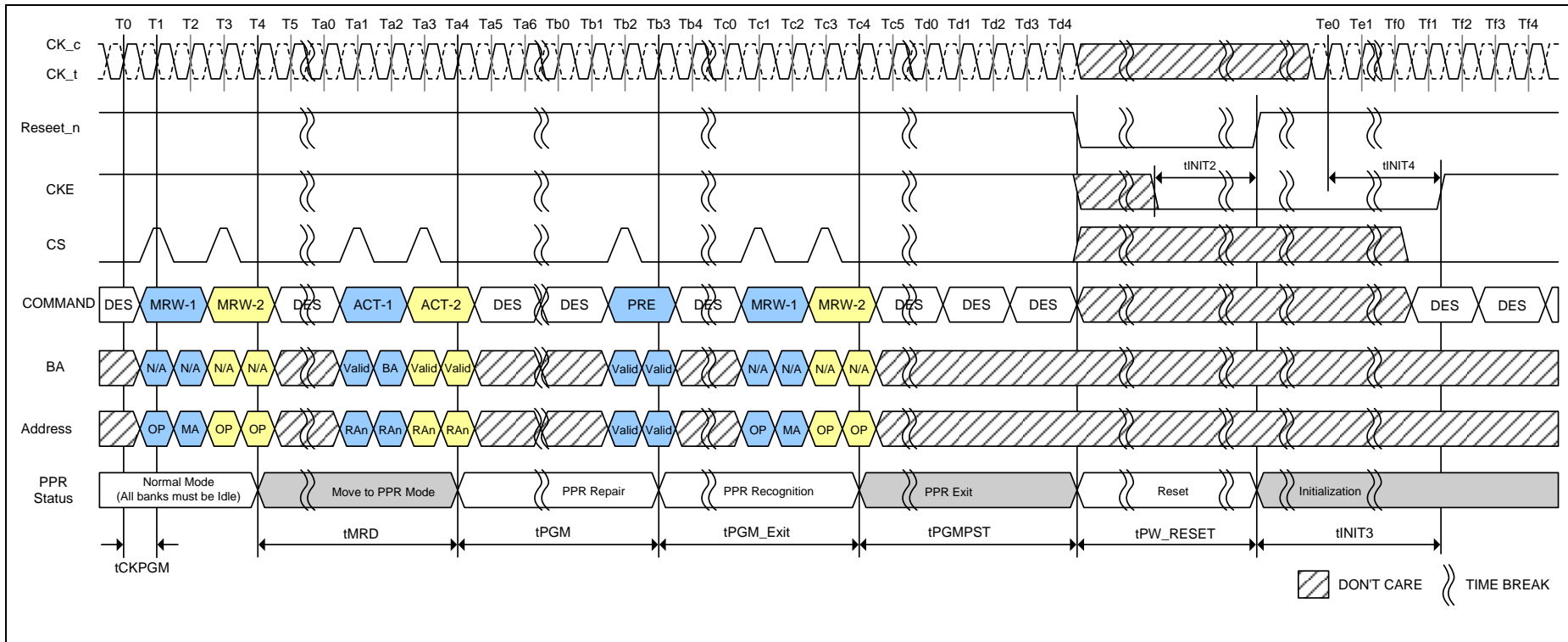

- Notes:**
1. During tPGM, any other commands (including refresh) are not allowed on each die.
  2. With one PPR command, only one row can be repaired at one time per die.
  3. RESET command is required at the end of every PPR procedure.
  4. During PPR, memory contents are not refreshed and may be lost.
  5. Assert Reset\_n below 0.2 X VDD2. Reset\_n needs to be maintained LOW for minimum tPW\_RESET. CKE must be pulled LOW at least 10nS before deasserting Reset\_n.
  6. After RESET command, follow steps 4 to 10 in 'Voltage Ramp and Device Initialization' section.

**Figure 145 - PPR Timing**  
**Table 87 - PPR Timing Parameters**

Parameter	Symbol	Min	Max	Unit	Note
PPR Programming Time	tPGM	1000	-	mS	
PPR Exit Time	tPGM_Exit	15	-	nS	
New Address Setting time	tPGMPST	50	-	µS	
PPR Programming Clock	tCKPGM	1.25	-	nS	





## 8. ELECTRICAL CHARACTERISTIC

### 8.1 Absolute Maximum DC Ratings

Stresses greater than those listed may cause permanent damage to the device.

This is a stress rating only, and functional operation of the device at these or any other conditions above those indicated in the operational sections of this specification is not implied. Exposure to absolute maximum rating conditions for extended periods may affect reliability.

Parameter	Symbol	Min	Max	Units	Notes
VDD1 supply voltage relative to VSS	VDD1	-0.4	+2.1	V	1
VDD2 supply voltage relative to VSS	VDD2	-0.4	+1.5	V	1
VDDQ supply voltage relative to VSS	VDDQ	-0.4	+1.5	V	1
Voltage on any ball except VDD1 relative to VSS	VIN, VOUT	-0.4	+1.5	V	
Storage Temperature	TSTG	-55	+125	°C	2

#### Notes:

1. See "Voltage Ramp" in section 7.2 for relationships between power supplies.
2. Storage Temperature is the case surface temperature on the center/top side of the LPDDR4X device. For the measurement conditions, please refer to JESD51-2.

### 8.2 AC & DC Operating Conditions

#### 8.2.1 Recommended DC Operating Conditions

DRAM	Symbol	Min	Typ	Max	Unit	Notes
Core 1 Power	VDD1	1.70	1.80	1.95	V	1, 2
Core 2 Power/ Input Buffer Power	VDD2	1.06	1.10	1.17	V	1, 2, 3
I/O Buffer Power	VDDQ	0.57	0.6	0.65	V	2, 3, 4, 5

#### Notes:

1. VDD1 uses significantly less power than VDD2.
2. The voltage range is for DC voltage only. DC is defined as the voltage supplied at the DRAM and is inclusive of all noise up to 20MHz at the DRAM package ball.
3. The voltage noise tolerance from DC to 20 MHz exceeding a pk-pk tolerance of 45 mV at the DRAM ball is not included in the TdIVW.
4. VDDQ(max) may be extended to 0.67 V as an option in case the operating clock frequency is equal or less than 800 MHz.
5. Pull up, pull down and ZQ calibration tolerance spec is valid only in normal VDDQ tolerance range (0.57 V - 0.65 V).
6. All parts list in section 3 order information table will not guarantee to meet functional and AC specification if the DC operation conditions out of range mentioned in above table.

#### 8.2.2 Input Leakage Current

Parameter/Condition	Symbol	Min	Max	Unit	Notes
Input Leakage current	IL	-4	4	μA	1, 2

#### Notes:

1. For CK\_t, CK\_c, CKE, CS, CA, ODT\_CA and RESET\_n. Any input  $0V \leq V_{IN} \leq V_{DD2}$  (All other pins not under test = 0V).
2. CA ODT is disabled for CK\_t, CK\_c, CS, and CA.

#### 8.2.3 Input/Output Leakage Current

Parameter/Condition	Symbol	Min	Max	Unit	Notes
Input/Output Leakage current	IOZ	-5	5	μA	1, 2

#### Notes:

1. For DQ, DQS\_t, DQS\_c and DMI. Any I/O  $0V \leq V_{OUT} \leq V_{DDQ}$ .
2. I/Os status are disabled: High Impedance and ODT Off.



## 8.2.4 Operating Temperature Range

Parameter/Condition	Symbol	Min	Max	Unit
Standard	TOPER	-40	85	°C
Elevated		85	105	°C

### Notes:

- Operating Temperature is the case surface temperature on the center-top side of the LPDDR4X device. For the measurement conditions, please refer to JESD51-2 standard.
- Some applications require operation of LPDDR4X in the maximum temperature conditions in the Elevated Temperature Range between 85°C and 105°C case temperature. For LPDDR4X devices, derating may be necessary to operate in this range. See MR4.
- Either the device case temperature rating or the temperature sensor (see 7.4.37) may be used to set an appropriate refresh rate, determine the need for AC timing de-rating and/or monitor the operating temperature. When using the temperature sensor, the actual device case temperature may be higher than the TOPER rating that applies for the Standard or Elevated Temperature Ranges. For example, T<sub>CASE</sub> may be above 85°C when the temperature sensor indicates a temperature of less than 85°C.
- All parts list in section 3 order information table will not guarantee to meet functional and AC specification if operating temperature out of the range in order information table.

## 8.3 AC and DC Input/Output Measurement levels

### 8.3.1 1.1 V High speed LVCMOS (HS\_LLVC MOS)

#### 8.3.1.1 Standard specifications

All voltages are referenced to ground except where noted.

#### 8.3.1.2 DC electrical characteristics

##### 8.3.1.2.1 LPDDR4X Input Level for CKE

Parameter	Symbol	Min	Max	Unit	Note
Input high level (AC)	V <sub>IH</sub> (AC)	0.75*V <sub>DD2</sub>	V <sub>DD2</sub> +0.2	V	1
Input low level (AC)	V <sub>IL</sub> (AC)	-0.2	0.25*V <sub>DD2</sub>	V	1
Input high level (DC)	V <sub>IH</sub> (DC)	0.65*V <sub>DD2</sub>	V <sub>DD2</sub> +0.2	V	
Input low level (DC)	V <sub>IL</sub> (DC)	-0.2	0.35*V <sub>DD2</sub>	V	

### Note:

- Refer LPDDR4X AC Over/Undershoot section.

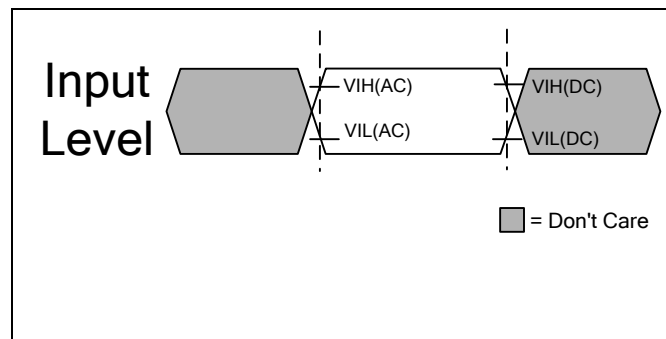

### Notes:

- AC level is guaranteed transition point.
- DC level is hysteresis.

Figure 146 - LPDDR4X Input AC timing definition for CKE



8.3.1.2.2 LPDDR4X Input Level for Reset\_n and ODT\_CA

Parameter	Symbol	Min	Max	Unit	Note
Input high level	VIH	0.80*VDD2	VDD2+0.2	V	1
Input low level	VIL	-0.2	0.20*VDD2	V	1

**Note:**

1. Refer LPDDR4X AC Over/Undershoot section.

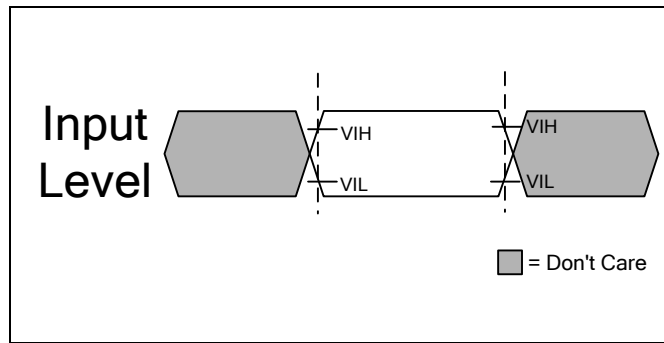

Figure 147 - LPDDR4X Input AC timing definition for Reset\_n and ODT\_CA

8.3.1.3 AC Over/Undershoot

8.3.1.3.1 LPDDR4X AC Over/Undershoot

Table 88 - LPDDR4X AC Over/Undershoot

Parameter	Specification
Maximum peak Amplitude allowed for overshoot area	0.35 V
Maximum peak Amplitude allowed for undershoot area	0.35 V
Maximum overshoot area above VDD/VDDQ	0.8 V-nS
Maximum undershoot area below VSS/VSSQ	0.8 V-nS

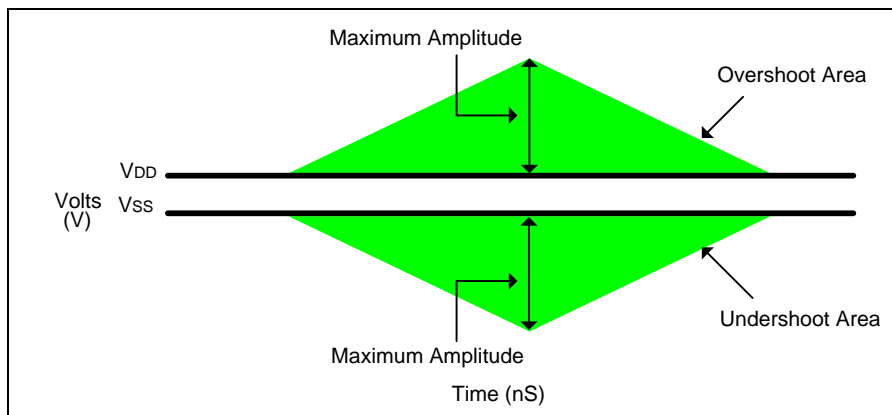

Figure 148 –AC Overshoot and Undershoot Definition for Address and Control Pins



8.3.2 Differential Input Voltage

8.3.2.1 Differential Input Voltage for CK

The minimum input voltage need to satisfy both Vindiff\_CK and Vindiff\_CK /2 specification at input receiver and their measurement period is 1 tCK. Vindiff\_CK is the peak to peak voltage centered on 0 volts differential and Vindiff\_CK /2 is max and min peak voltage from 0V.

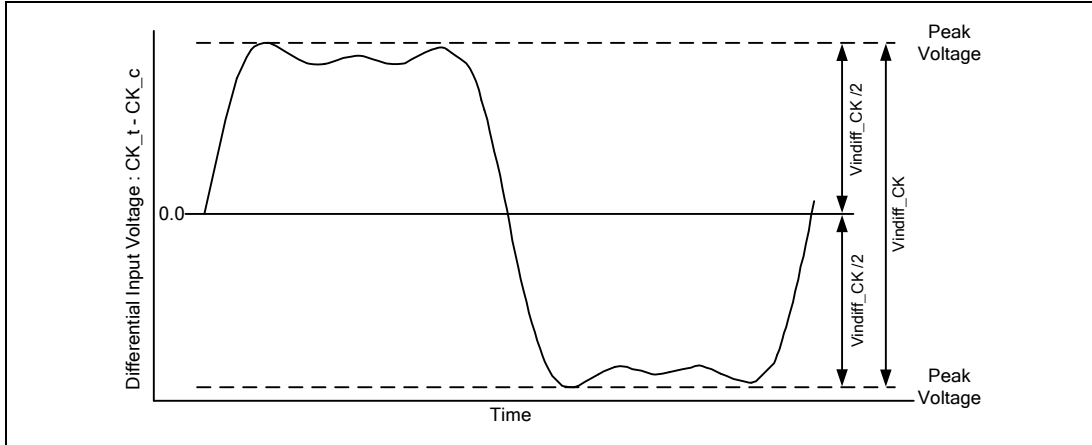

Figure 149 - CK Differential Input Voltage

Table 89 - CK differential input voltage

Parameter	Symbol	Data Rate						Unit	Note
		1600/1867 <sup>*a</sup>		2133/2400/3200		3733/4267			
		Min	Max	Min	Max	Min	Max		
CK differential input voltage	Vindiff_CK	420	-	380	-	360	-	mV	1

a. The following requirements apply for DQ operating frequencies at or below 1333Mbps for all speed bins for the first column 1600/1867.

Note:

1. The peak voltage of Differential CK signals is calculated in a following equation.

$$Vindiff\_CK = (\text{Max Peak Voltage}) - (\text{Min Peak Voltage})$$

$$\text{Max Peak Voltage} = \text{Max}(f(t))$$

$$\text{Min Peak Voltage} = \text{Min}(f(t))$$

$$f(t) = VCK\_t - VCK\_c$$



### 8.3.2.2 Peak voltage calculation method

The peak voltage of Differential Clock signals are calculated in a following equation.

$$V_{IH.DIFF.PEAK\ Voltage} = \text{Max}(f(t))$$

$$V_{IL.DIFF.PEAK\ Voltage} = \text{Min}(f(t))$$

$$f(t) = V_{CK\_t} - V_{CK\_c}$$

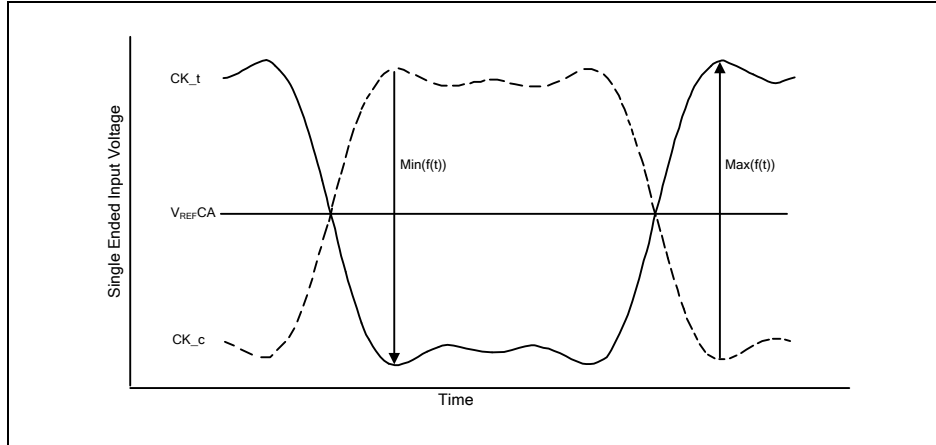

**Note:** 1.  $V_{REFCA}$  is LPDDR4X SDRAM internal setting value by  $V_{REF}$  Training.

**Figure 150 - Definition of Differential Clock Peak Voltage**



**8.3.2.3 Single-Ended Input Voltage for Clock**

The minimum input voltage need to satisfy both Vinse\_CK, Vinse\_CK\_High/Low specification at input receiver.

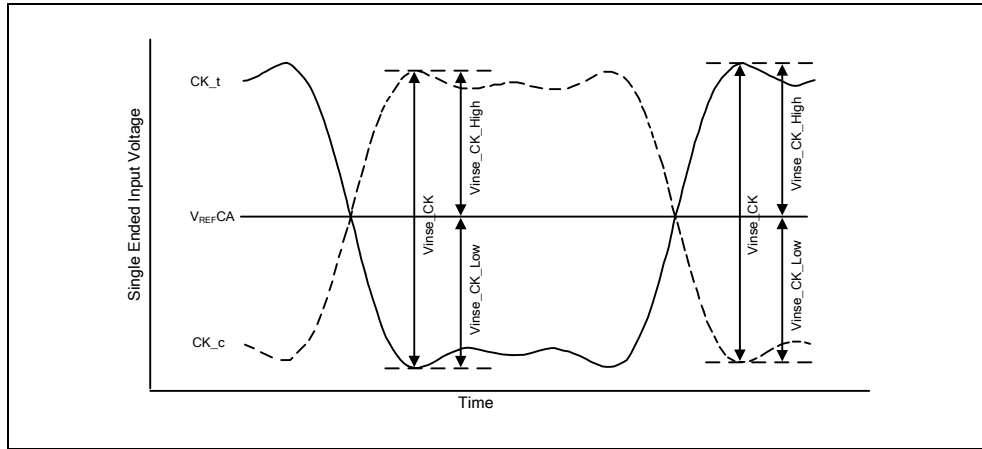

**Note:** 1. V<sub>REFCA</sub> is LPDDR4X SDRAM internal setting value by V<sub>REF</sub> Training.

**Figure 151 - Clock Single-Ended Input Voltage**

**Table 90 - Clock Single-Ended input voltage**

Parameter	Symbol	Data Rate						Unit	Note
		1600/1867* <sup>a</sup>		2133/2400/3200		3733/4267			
		Min	Max	Min	Max	Min	Max		
Clock Single-Ended input voltage	Vinse_CK	210	-	190	-	180	-	mV	
Clock Single-Ended input voltage High from V <sub>REFDQ</sub>	Vinse_CK_High	105	-	95	-	90	-	mV	
Clock Single-Ended input voltage Low from V <sub>REFDQ</sub>	Vinse_CK_Low	105	-	95	-	90	-	mV	

a. The following requirements apply for DQ operating frequencies at or below 1333Mbps for all speed bins for the first column 1600/1867.



8.3.2.4 Differential Input Slew Rate Definition for Clock

Input slew rate for differential signals (CK\_t, CK\_c) are defined and measured as shown in Figure 152 and the following Tables.

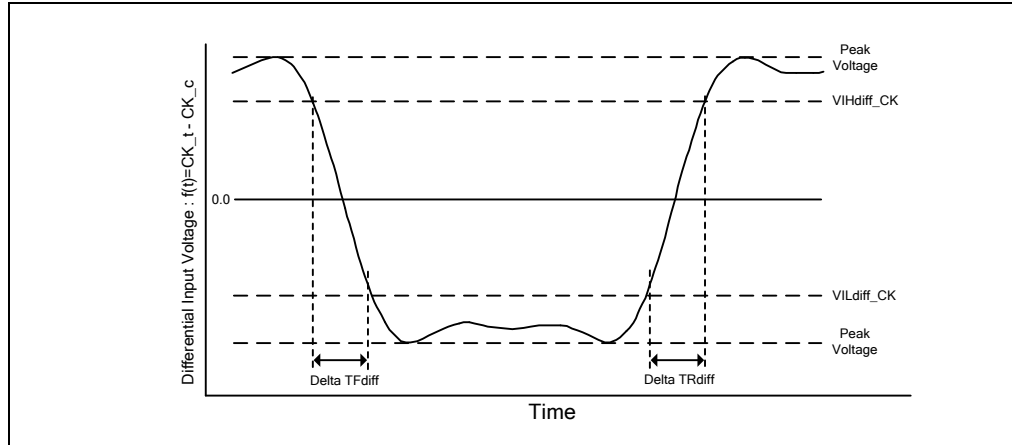

Notes:

1. Differential signal rising edge from VILdiff\_CK to VIHdiff\_CK must be monotonic slope.
2. Differential signal falling edge from VIHdiff\_CK to VILdiff\_CK must be monotonic slope.

Figure 152 - Differential Input Slew Rate Definition for CK\_t, CK\_c

Table 91 - Differential Input Slew Rate Definition for CK\_t, CK\_c

Description	From	To	Defined by
	Differential input slew rate for rising edge(CK_t - CK_c)	VILdiff_CK	
Differential input slew rate for falling edge(CK_t - CK_c)	VIHdiff_CK	VILdiff_CK	$ VILdiff\_CK - VIHdiff\_CK /DeltaTFdiff$

Table 92 - Differential Input Level for CK\_t, CK\_c

Parameter	Symbol	Data Rate						Unit	Note
		1600/1867* <sup>a</sup>		2133/2400/3200		3733/4267			
		Min	Max	Min	Max	Min	Max		
Differential Input High	VIHdiff_CK	175	-	155	-	145	-	mV	
Differential Input Low	VILdiff_CK	-	-175	-	-155	-	-145	mV	

a. The following requirements apply for DQ operating frequencies at or below 1333Mbps for all speed bins for the first column 1600/1867.

Table 93 - Differential Input Slew Rate for CK\_t, CK\_c

Parameter	Symbol	Data Rate						Unit	Note
		1600/1867		2133/2400/3200		3733/4267			
		Min	Max	Min	Max	Min	Max		
Differential Input Slew Rate for Clock	SRIdiff_CK	2	14	2	14	2	14	V/nS	



**8.3.2.5 Differential Input Cross Point Voltage**

The cross point voltage of differential input signals (CK\_t, CK\_c) must meet the requirements in Table 94.

The differential input cross point voltage VIX is measured from the actual cross point of true and complement signals to the mid level.

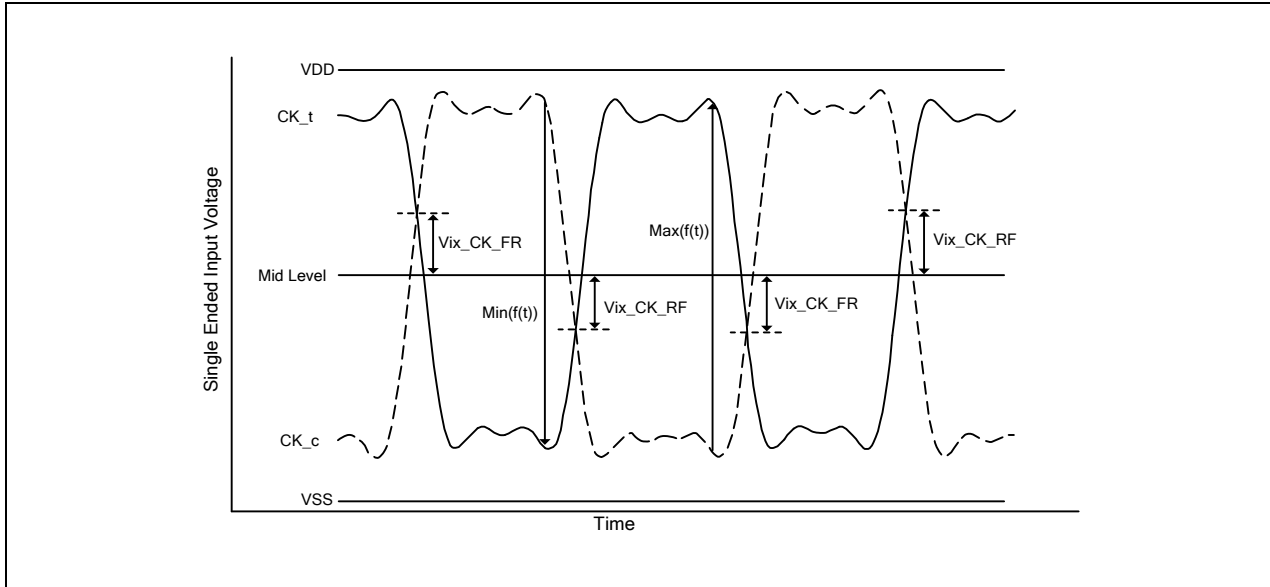

**Note:** 1. The base level of Vix\_CK\_FR/RF is VREFCA that is LPDDR4X SDRAM internal setting value by VREF Training.

**Figure 153 - Vix Definition (Clock)**

**Table 94 - Cross point voltage for differential input signals (Clock)**

Parameter	Symbol	Data Rate						Unit	Note
		1600/1867 <sup>*a</sup>		2133/2400/3200		3733/4267			
		Min	Max	Min	Max	Min	Max		
Clock Differential input cross point voltage ratio	Vix_CK_ratio	-	25	-	25	-	25	%	1, 2

a. The following requirements apply for DQ operating frequencies at or below 1333Mbps for all speed bins for the first column 1600/1867.

**Notes:**

- Vix\_CK\_Ratio is defined by this equation:  $Vix\_CK\_Ratio = Vix\_CK\_FR / |Min(f(t))|$ .
- Vix\_CK\_Ratio is defined by this equation:  $Vix\_CK\_Ratio = Vix\_CK\_RF / Max(f(t))$ .
- Vix\_CK\_FR is defined as delta between cross point (CK\_t fall, CK\_c rise) to  $Min(f(t))/2$ .
- Vix\_CK\_RF is defined as delta between cross point (CK\_t rise, CK\_c fall) to  $Max(f(t))/2$ .
- In LPDDR4X un-terminated case, CK mid-level is calculated as:  
High level = VDDQ, Low level=VSS, Mid-level =  $VDDQ/2$ .





**8.3.2.6 Differential Input Voltage for DQS**

The minimum input voltage need to satisfy both Vindiff\_DQS and Vindiff\_DQS /2 specification at input receiver and their measurement period is 1UI(tCK/2). Vindiff\_DQS is the peak to peak voltage centered on 0 volts differential and Vindiff\_DQS /2 is max and min peak voltage from 0V.

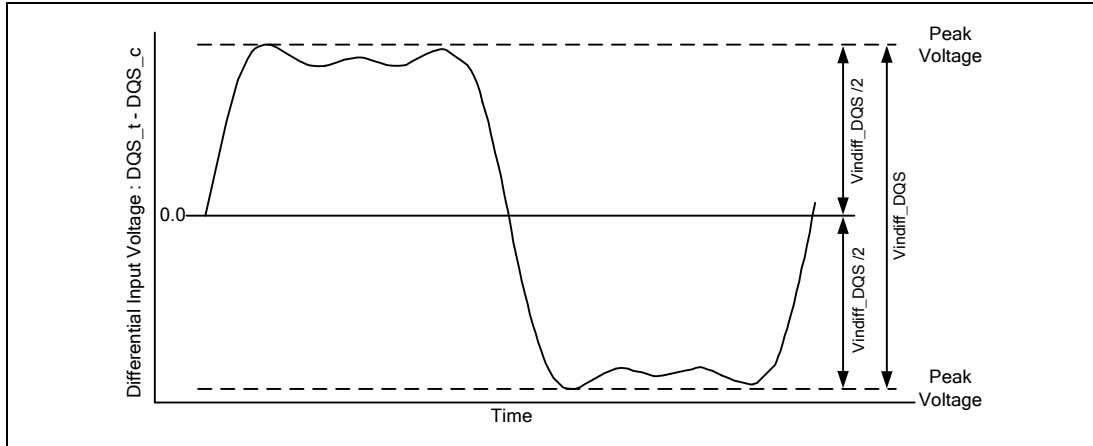

**Figure 154 –DQS Differential Input Voltage**

**Table 95 - DQS differential input voltage**

Parameter	Symbol	Data Rate						Unit	Note
		1600/1867 <sup>*a</sup>		2133/2400/3200		3733/4267			
		Min	Max	Min	Max	Min	Max		
DQS differential input	Vindiff_DQS	360	-	360	-	340	-	mV	1

a. The following requirements apply for DQ operating frequencies at or below 1333Mbps for all speed bins for the first column 1600/1867.

**Note:**

1. The peak voltage of Differential DQS signals is calculated in a following equation.

$$V_{indiff\_DQS} = (\text{Max Peak Voltage}) - (\text{Min Peak Voltage})$$

$$\text{Max Peak Voltage} = \text{Max}(f(t))$$

$$\text{Min Peak Voltage} = \text{Min}(f(t))$$

$$f(t) = VDQS\_t - VDQS\_c$$



### 8.3.2.7 Peak voltage calculation method

The peak voltage of Differential DQS signals are calculated in a following equation.

$$V_{IH.DIFF.Peak Voltage} = \text{Max}(f(t))$$

$$V_{IL.DIFF.Peak Voltage} = \text{Min}(f(t))$$

$$f(t) = VDQS\_t - VDQS\_c$$

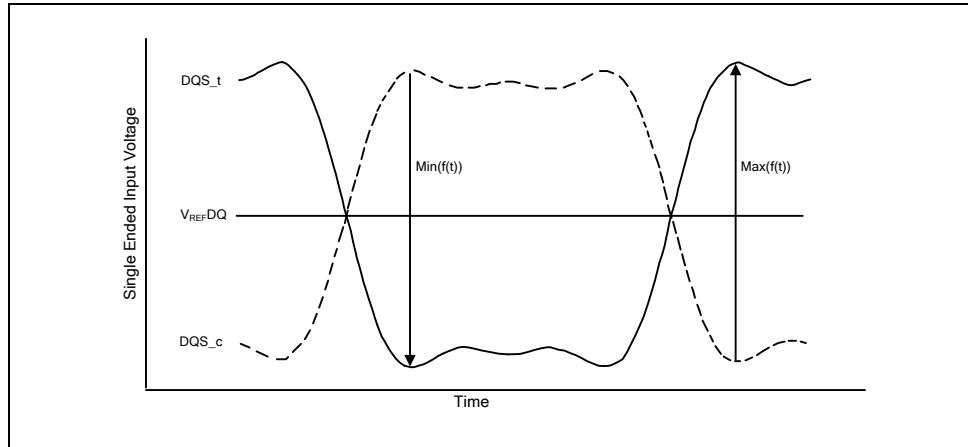

**Note:** 1.  $V_{REFDQ}$  is LPDDR4X SDRAM internal setting value by  $V_{REF}$  Training.

**Figure 155 - Definition of differential DQS Peak Voltage**



8.3.2.8 Single-Ended Input Voltage for DQS

The minimum input voltage need to satisfy both Vinse\_DQS, Vinse\_DQS\_High/Low specification at input receiver.

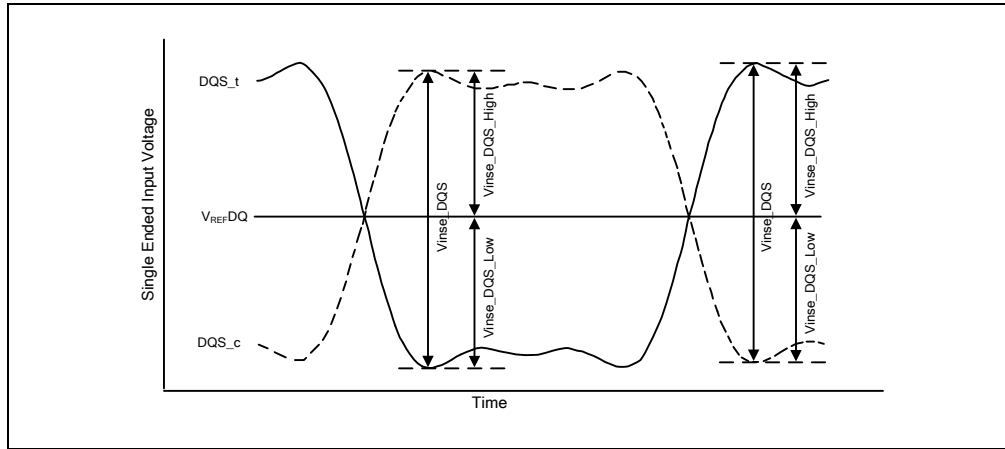

Note: 1. VREFDQ is LPDDR4X SDRAM internal setting value by VREF Training.

Figure 156 - DQS Single-Ended Input Voltage

Table 96 - DQS Single-Ended input voltage

Parameter	Symbol	Data Rate						Unit	Note
		1600/1867* <sup>a</sup>		2133/2400/3200		3733/4267			
		Min	Max	Min	Max	Min	Max		
DQS Single-Ended input voltage	Vinse_DQS	180	-	180	-	170	-	mV	
DQS Single-Ended input voltage High from VREFDQ	Vinse_DQS_High	90	-	90	-	85	-	mV	
DQS Single-Ended input voltage Low from VREFDQ	Vinse_DQS_Low	90	-	90	-	85	-	mV	

a. The following requirements apply for DQ operating frequencies at or below 1333Mbps for all speed bins for the first column 1600/1867.



**8.3.2.9 Differential Input Slew Rate Definition for DQS**

Input slew rate for differential signals (DQS\_t, DQS\_c) are defined and measured as shown in Figure 157 and Table 97.

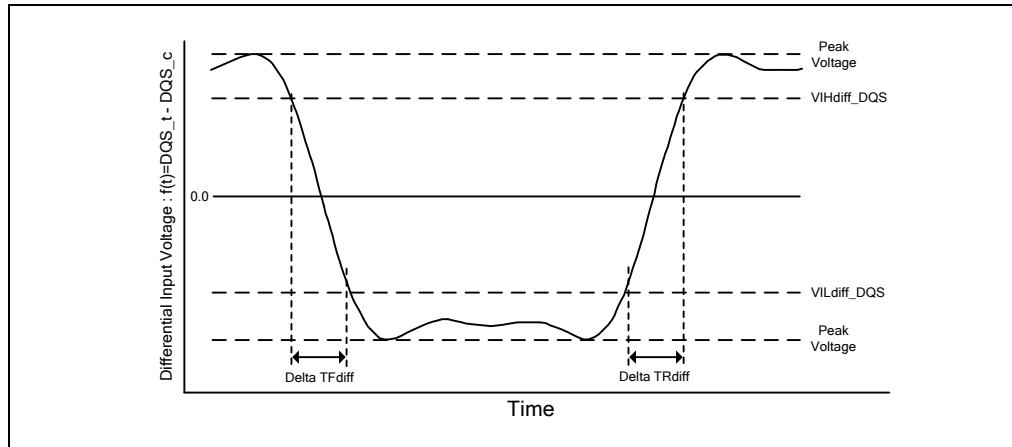

**Notes:**

1. Differential signal rising edge from VILdiff\_DQS to VIHdiff\_DQS must be monotonic slope.
2. Differential signal falling edge from VIHdiff\_DQS to VILdiff\_DQS must be monotonic slope.

**Figure 157 - Differential Input Slew Rate Definition for DQS\_t, DQS\_c**

**Table 97 - Differential Input Slew Rate Definition for DQS\_t, DQS\_c**

Description	From	To	Defined by
	Differential input slew rate for rising edge(DQS_t - DQS_c)	VILdiff_DQS	
Differential input slew rate for falling edge(DQS_t - DQS_c)	VIHdiff_DQS	VILdiff_DQS	$ VILdiff\_DQS - VIHdiff\_DQS /DeltaTFdiff$

**Table 98 - Differential Input Level for DQS\_t, DQS\_c**

Parameter	Symbol	Data Rate						Unit	Note
		1600/1867* <sup>a</sup>		2133/2400/3200		3733/4267			
		Min	Max	Min	Max	Min	Max		
Differential Input High	VIHdiff_DQS	140	-	140	-	120	-	mV	
Differential Input Low	VILdiff_DQS	-	-140	-	-140	-	-120	mV	

a. The following requirements apply for DQ operating frequencies at or below 1333Mbps for all speed bins for the first column 1600/1867.

**Table 99 - Differential Input Slew Rate for DQS\_t, DQS\_c**

Parameter	Symbol	Data Rate						Unit	Note
		1600/1867		2133/2400/3200		3733/4267			
		Min	Max	Min	Max	Min	Max		
Differential Input Slew Rate	SRIdiff	2	14	2	14	2	14	V/nS	



**8.3.2.10 Differential Input Cross Point Voltage**

The cross point voltage of differential input signals (DQS\_t, DQS\_c) must meet the requirements in Table 100. The differential input cross point voltage VIX is measured from the actual cross point of true and complement signals to the mid level that is VREFDQ.

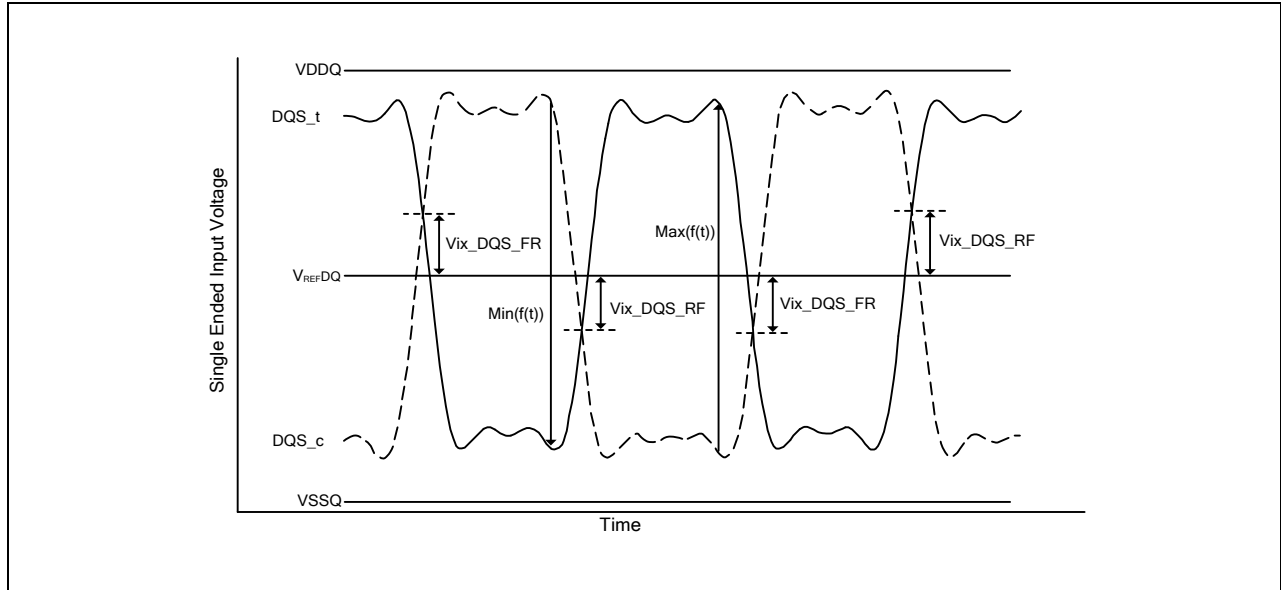

**Note:** 1. The base level of Vix\_DQS\_FR/RF is VREFDQ that is LPDDR4X SDRAM internal setting value by VREF Training.

**Figure 158 - Vix Definition (DQS)**

**Table 100 - Cross point voltage for differential input signals (DQS)**

Parameter	Symbol	Data Rate						Unit	Note
		1600/1867 <sup>a</sup>		2133/2400/3200		3733/4267			
		Min	Max	Min	Max	Min	Max		
DQS Differential input cross point voltage ratio	Vix_DQS_ratio	-	20	-	20	-	20	%	1,2

a. The following requirements apply for DQ operating frequencies at or below 1333Mbps for all speed bins for the first column 1600/1867.

**Notes:**

1. Vix\_DQS\_Ratio is defined by this equation:  $Vix\_DQS\_Ratio = Vix\_DQS\_FR / |Min(f(t))|$ .
2. Vix\_DQS\_Ratio is defined by this equation:  $Vix\_DQS\_Ratio = Vix\_DQS\_RF / Max(f(t))$ .



### 8.3.3 Input level for ODT\_CA input

Table 101 - LPDDR4X Input Level for ODT\_CA

Symbol		Min	Max	Unit	Note
VIHODT	ODT Input High Level	$0.75 \cdot V_{DD2}$	$V_{DD2} + 0.2$	V	
VILODT	ODT Input Low Level	-0.2	$0.25 \cdot V_{DD2}$	V	

### 8.3.4 Single Ended Output Slew Rate

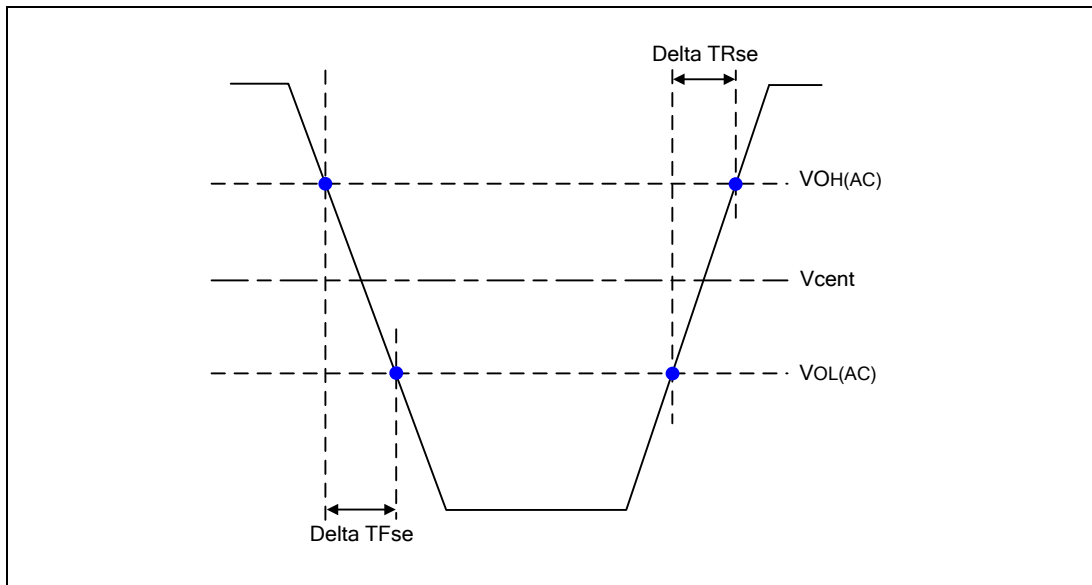

Figure 159 - Single Ended Output Slew Rate Definition

Table 102 - Output Slew Rate (Single-ended) for 0.6 V VDDQ

Parameter	Symbol	Value		Units
		Min <sup>*1</sup>	Max <sup>*2</sup>	
Single-ended Output Slew Rate ( $VOH = V_{DDQ} \cdot 0.5$ )	SRQse	3.0	9	V/nS
Output slew-rate matching Ratio (Rise to Fall)	-	0.8	1.2	-

**Description:**

**SR:** Slew Rate

**Q:** Query Output (like in DQ, which stands for Data-in, Query-Output)

**se:** Single-ended Signals

**Notes:**

1. Measured with output reference load.
2. The ratio of pull-up to pull-down slew rate is specified for the same temperature and voltage, over the entire temperature and voltage range. For a given output, it represents the maximum difference between pull-up and pull-down drivers due to process variation.
3. The output slew rate for falling and rising edges is defined and measured between  $VOL(AC) = 0.2 \cdot VOH(DC)$  and  $VOH(AC) = 0.8 \cdot VOH(DC)$ .
4. Slew rates are measured under normal SSO conditions, with 50% of DQ signals per data byte switching.



### 8.3.5 Differential Output Slew Rate

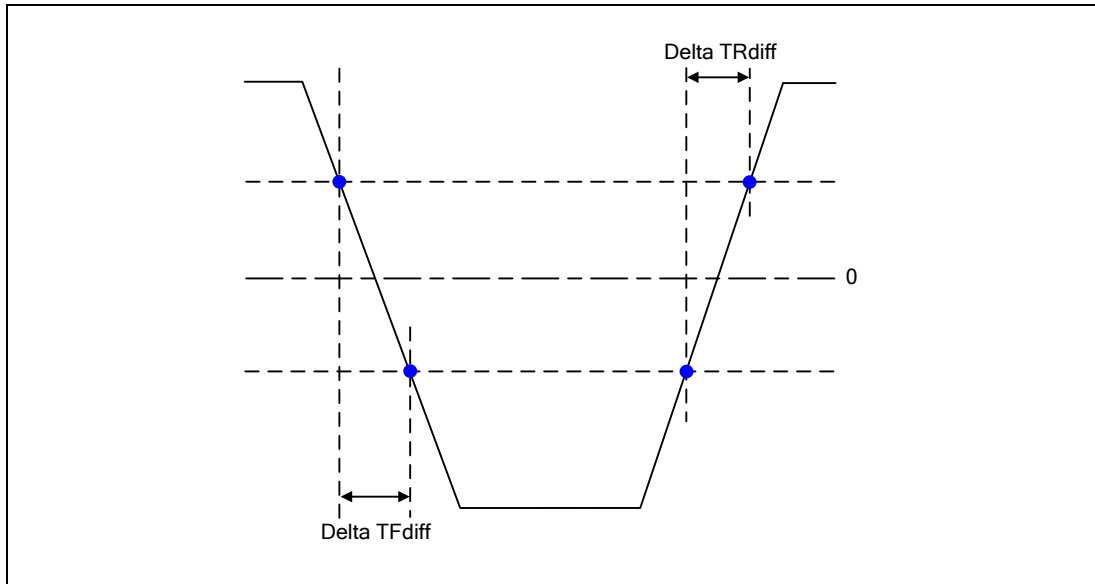

Figure 160 - Differential Output Slew Rate Definition

Table 103 - Differential Output Slew Rate for 0.6 V VDDQ

Parameter	Symbol	Value		Units
		Min	Max	
Differential Output Slew Rate ( $V_{OH} = V_{DDQ} * 0.5$ )	SRQdiff	6	18	V/nS

**Description:**

**SR:** Slew Rate

**Q:** Query Output (like in DQ, which stands for Data-in, Query-Output)

**diff:** Differential Signals

**Notes:**

1. Measured with output reference load.
2. The output slew rate for falling and rising edges is defined and measured between  $V_{OL(AC)} = -0.8 * V_{OH(DC)}$  and  $V_{OH(AC)} = 0.8 * V_{OH(DC)}$ .
3. Slew rates are measured under normal SSO conditions, with 50% of DQ signals per data byte switching.



## 8.3.6 Overshoot and Undershoot for LVSTL

Table 104 - AC Overshoot/Undershoot Specification

Parameter		Data Rate					Unit
		1600	1866	3200	3733	4267	
Maximum peak amplitude allowed for overshoot area. (See Figure 161)	Max	0.3	0.3	0.3	TBD	TBD	V
Maximum peak amplitude allowed for undershoot area. (See Figure 161)	Max	0.3	0.3	0.3	TBD	TBD	V
Maximum area above VDD. (See Figure 161)	Max	0.1	0.1	0.1	TBD	TBD	V-nS
Maximum area below VSS. (See Figure 161)	Max	0.1	0.1	0.1	TBD	TBD	V-nS

**Notes:**

1. VDD2 stands for VDD for CA[5:0], CK\_t, CK\_c, CS\_n, CKE and ODT. VDD stands for VDDQ for DQ, DMI, DQS\_t and DQS\_c.
2. VSS stands for VSS for CA[5:0], CK\_t, CK\_c, CS\_n, CKE and ODT. VSS stands for VSSQ for DQ, DMI, DQS\_t and DQS\_c.
3. Maximum peak amplitude values are referenced from actual VDD and VSS values.
4. Maximum area values are referenced from maximum operating VDD and VSS values.

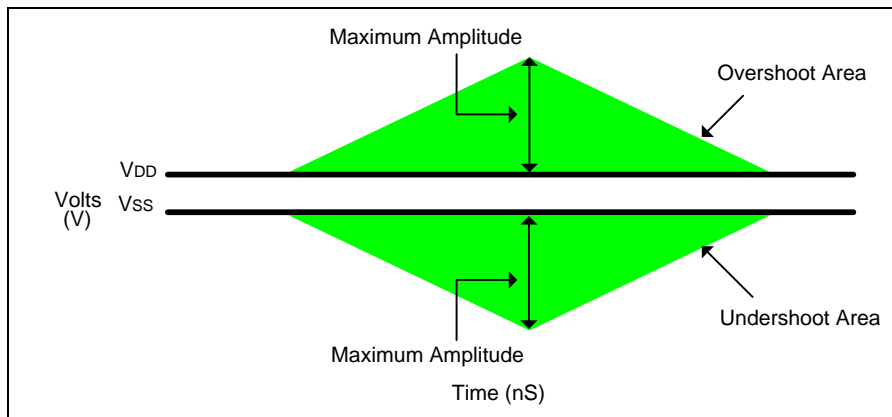

Figure 161 - Overshoot and Undershoot Definition





### 8.3.7 LPDDR4X Driver Output Timing Reference load

These 'Timing Reference Loads' are not intended as a precise representation of any particular system environment or a depiction of the actual load presented by a production tester. System designers should use IBIS or other simulation tools to correlate the timing reference load to a system environment. Manufacturers correlate to their production test conditions, generally one or more coaxial transmission lines terminated at the tester electronics.

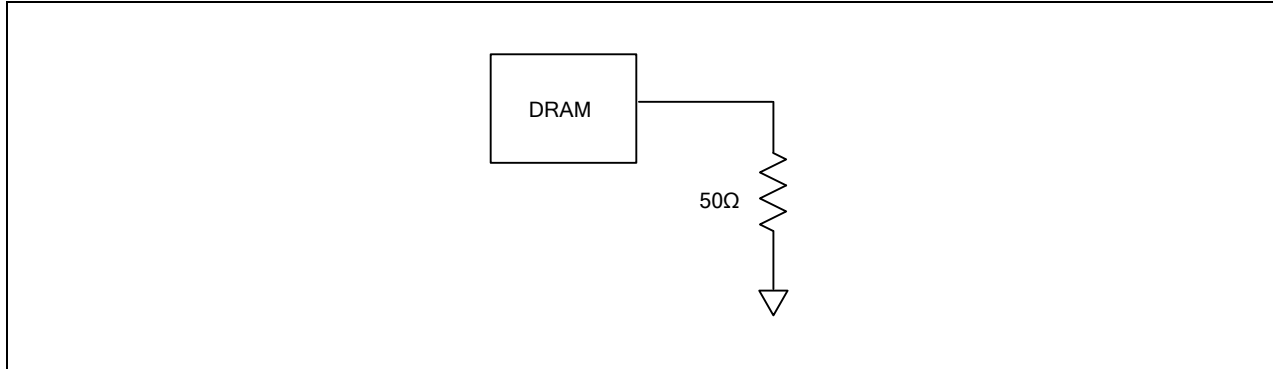

**Note:**

1. All output timing parameter values are reported with respect to this reference load.

This reference load is also used to report slew rate.

**Figure 162 - Driver Output Reference Load for Timing and Slew Rate**

### 8.3.8 LVSTL (Low Voltage Swing Terminated Logic) IO System

LVSTL I/O cell is comprised of pull-up, pull-down driver and a terminator. The basic cell is shown in Figure 163.

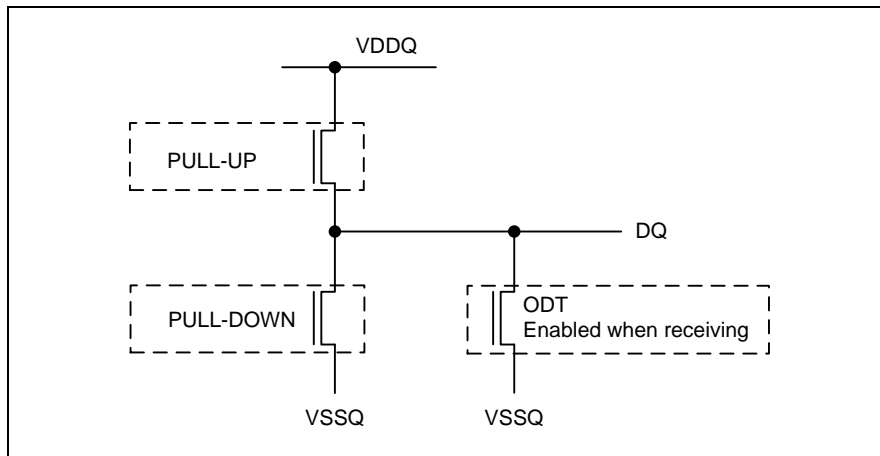
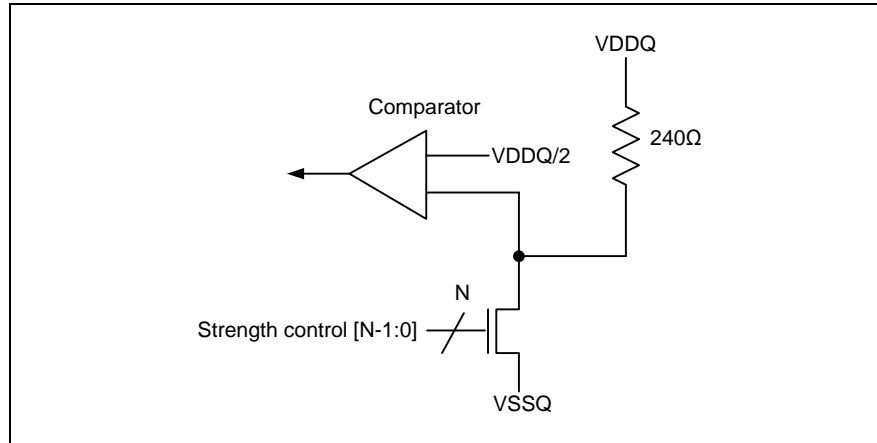

**Figure 163 - LVSTL I/O Cell**



To ensure that the target impedance is achieved the LVSTL I/O cell is designed to be calibrated as below procedure.

1. First calibrate the pull-down device against a  $240\ \Omega$  resistor to VDDQ via the ZQ pin.
  - Set Strength Control to minimum setting
  - Increase drive strength until comparator detects data bit is less than  $VDDQ/2$
  - NMOS pull-down device is calibrated to  $240\ \Omega$



**Figure 164 - Pull-down calibration**

2. Then calibrate the pull-up device against the calibrated pull-down device.
  - Set VOH target and NMOS controller ODT replica via MRS (VOH can be automatically controlled by ODT MRS)
  - Set Strength Control to minimum setting
  - Increase drive strength until comparator detects data bit is greater than VOH target
  - NMOS pull-up device is now calibrated to VOH target

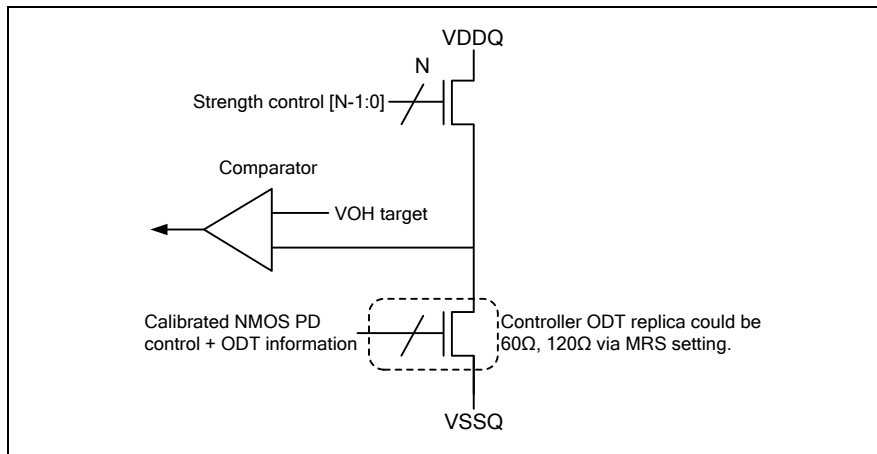

**Figure 165 - Pull-up calibration**



## 8.4 Input/Output Capacitance

Table 105 - Input/Output Capacitance

Parameter	Symbol		LPDDR4X 533-3200	LPDDR4X 3733-4267	Units	Notes
Input capacitance, CK_t and CK_c	CCK	Min	0.5	TBD	pF	1, 2
		Max	0.9	TBD		1, 2
Input capacitance delta, CK_t and CK_c	CDCK	Min	0	TBD	pF	1, 2, 3
		Max	0.09	TBD		1, 2, 3
Input capacitance, all other input-only pins	CI	Min	0.5	TBD	pF	1, 2, 4
		Max	0.9	TBD		1, 2, 4
Input capacitance delta, all other input-only pins	CDI	Min	-0.1	TBD	pF	1, 2, 5
		Max	0.1	TBD		1, 2, 5
Input/output capacitance, DQ, DMI, DQS_t, DQS_c	CIO	Min	0.7	TBD	pF	1, 2, 6
		Max	1.3	TBD		1, 2, 6
Input/output capacitance delta, DQS_t, DQS_c	CDDQS	Min	0	TBD	pF	1, 2, 7
		Max	0.1	TBD		1, 2, 7
Input/output capacitance delta, DQ, DM	CDIO	Min	-0.1	TBD	pF	1, 2, 8
		Max	0.1	TBD		1, 2, 8
Input/output capacitance, ZQ pin	CZQ	Min	0	TBD	pF	1, 2
		Max	5	TBD		1, 2

### Notes:

1. This parameter applies to die device only (does not include package capacitance).
2. This parameter is not subject to production test. It is verified by design and characterization. The capacitance is measured according to JEP147 (Procedure for measuring input capacitance using a vector network analyzer (VNA) with VDD1, VDD2, VDDQ, VSS, VSSQ applied and all other pins floating).
3. Absolute value of CCK\_t . CCK\_c.
4. CI applies to CS\_n, CKE, CA0~CA5.
5.  $CDI = CI \cdot 0.5 \cdot (CCK\_t + CCK\_c)$ .
6. DMI loading matches DQ and DQS.
7. Absolute value of CDQS\_t and CDQS\_c.
8.  $CDIO = CIO \cdot 0.5 \cdot (CDQS\_t + CDQS\_c)$  in byte-lane.



## 8.5 IDD Specification Parameters and Test Conditions

### 8.5.1 IDD Measurement Conditions

The following definitions are used within the IDD measurement tables unless stated otherwise:

LOW:  $V_{IN} \leq V_{IL(DC) MAX}$

HIGH:  $V_{IN} \geq V_{IH(DC) MIN}$

STABLE: Inputs are stable at a HIGH or LOW level

SWITCHING: See Table 106 and Table 107.

**Table 106 - Definition of Switching for CA Input Signals**

Switching for CA								
CK_t edge	R1	R2	R3	R4	R5	R6	R7	R8
CKE	HIGH	HIGH	HIGH	HIGH	HIGH	HIGH	HIGH	HIGH
CS	LOW	LOW	LOW	LOW	LOW	LOW	LOW	LOW
CA0	HIGH	LOW	LOW	LOW	LOW	HIGH	HIGH	HIGH
CA1	HIGH	HIGH	HIGH	LOW	LOW	LOW	LOW	HIGH
CA2	HIGH	LOW	LOW	LOW	LOW	HIGH	HIGH	HIGH
CA3	HIGH	HIGH	HIGH	LOW	LOW	LOW	LOW	HIGH
CA4	HIGH	LOW	LOW	LOW	LOW	HIGH	HIGH	HIGH
CA5	HIGH	HIGH	HIGH	LOW	LOW	LOW	LOW	HIGH

**Notes:**

1. CS must always be driven LOW.
2. 50% of CA bus is changing between HIGH and LOW once per clock for the CA bus.
3. The pattern is used continuously during IDD measurement for IDD values that require switching on the CA bus.

**Table 107 - CA pattern for lDD4R**

Clock Cycle Number	CKE	CS	Command	CA0	CA1	CA2	CA3	CA4	CA5
N	HIGH	HIGH	Read-1	L	H	L	L	L	L
N+1	HIGH	LOW		L	H	L	L	L	L
N+2	HIGH	HIGH	CAS-2	L	H	L	L	H	L
N+3	HIGH	LOW		L	L	L	L	L	L
N+4	HIGH	LOW	DES	L	L	L	L	L	L
N+5	HIGH	LOW	DES	L	L	L	L	L	L
N+6	HIGH	LOW	DES	L	L	L	L	L	L
N+7	HIGH	LOW	DES	L	L	L	L	L	L
N+8	HIGH	HIGH	Read-1	L	H	L	L	L	L
N+9	HIGH	LOW		L	H	L	L	H	L
N+10	HIGH	HIGH	CAS-2	L	H	L	L	H	H
N+11	HIGH	LOW		H	H	H	H	H	H
N+12	HIGH	LOW	DES	L	L	L	L	L	L
N+13	HIGH	LOW	DES	L	L	L	L	L	L
N+14	HIGH	LOW	DES	L	L	L	L	L	L
N+15	HIGH	LOW	DES	L	L	L	L	L	L

**Notes:**

1. BA[2:0] = 010, C[9:4] = 000000 or 111111, Burst Order C[3:2] = 00 or 11 (Same as LPDDR3 IDD4R).
2. Difference from LPDDR3 (JESD209-3): CA pins are kept low with DES CMD to reduce ODT current.



Table 108 - CA pattern for IDD4W

Clock Cycle Number	CKE	CS	Command	CA0	CA1	CA2	CA3	CA4	CA5
N	HIGH	HIGH	Write-1	L	L	H	L	L	L
N+1	HIGH	LOW		L	H	L	L	L	L
N+2	HIGH	HIGH	CAS-2	L	H	L	L	H	L
N+3	HIGH	LOW		L	L	L	L	L	L
N+4	HIGH	LOW	DES	L	L	L	L	L	L
N+5	HIGH	LOW	DES	L	L	L	L	L	L
N+6	HIGH	LOW	DES	L	L	L	L	L	L
N+7	HIGH	LOW	DES	L	L	L	L	L	L
N+8	HIGH	HIGH	Write-1	L	L	H	L	L	L
N+9	HIGH	LOW		L	H	L	L	H	L
N+10	HIGH	HIGH	CAS-2	L	H	L	L	H	H
N+11	HIGH	LOW		L	L	H	H	H	H
N+12	HIGH	LOW	DES	L	L	L	L	L	L
N+13	HIGH	LOW	DES	L	L	L	L	L	L
N+14	HIGH	LOW	DES	L	L	L	L	L	L
N+15	HIGH	LOW	DES	L	L	L	L	L	L

**Notes:**

1. BA[2:0] = 010, C[9:4] = 000000 or 111111 (Same as LPDDR3 IDD4W).
2. Difference from LPDDR3 (JESD209-3): 1)-No burst ordering, and 2) CA pins are kept low with DES CMD to reduce ODT current.



Table 109 - Data pattern for IDD4W (DBI off)

DBI OFF Case										No. of 1's
	DQ[7]	DQ[6]	DQ[5]	DQ[4]	DQ[3]	DQ[2]	DQ[1]	DQ[0]	DBI	
BL0	1	1	1	1	1	1	1	1	0	8
BL1	1	1	1	1	0	0	0	0	0	4
BL2	0	0	0	0	0	0	0	0	0	0
BL3	0	0	0	0	1	1	1	1	0	4
BL4	0	0	0	0	0	0	1	1	0	2
BL5	0	0	0	0	1	1	1	1	0	4
BL6	1	1	1	1	1	1	0	0	0	6
BL7	1	1	1	1	0	0	0	0	0	4
BL8	1	1	1	1	1	1	1	1	0	8
BL9	1	1	1	1	0	0	0	0	0	4
BL10	0	0	0	0	0	0	0	0	0	0
BL11	0	0	0	0	1	1	1	1	0	4
BL12	0	0	0	0	0	0	1	1	0	2
BL13	0	0	0	0	1	1	1	1	0	4
BL14	1	1	1	1	1	1	0	0	0	6
BL15	1	1	1	1	0	0	0	0	0	4
BL16	1	1	1	1	1	1	0	0	0	6
BL17	1	1	1	1	0	0	0	0	0	4
BL18	0	0	0	0	0	0	1	1	0	2
BL19	0	0	0	0	1	1	1	1	0	4
BL20	0	0	0	0	0	0	0	0	0	0
BL21	0	0	0	0	1	1	1	1	0	4
BL22	1	1	1	1	1	1	1	1	0	8
BL23	1	1	1	1	0	0	0	0	0	4
BL24	0	0	0	0	0	0	1	1	0	2
BL25	0	0	0	0	1	1	1	1	0	4
BL26	1	1	1	1	1	1	0	0	0	6
BL27	1	1	1	1	0	0	0	0	0	4
BL28	1	1	1	1	1	1	1	1	0	8
BL29	1	1	1	1	0	0	0	0	0	4
BL30	0	0	0	0	0	0	0	0	0	0
BL31	0	0	0	0	1	1	1	1	0	4
No. of 1's	16	16	16	16	16	16	16	16		

**Note:**

1. Simplified pattern compared predecessor. Same data pattern was applied to DQ[4], DQ[5], DQ[6], DQ[7] for reducing complexity for IDD4W/R pattern programming.



Table 110 - Data pattern for IDD4R (DBI off)

DBI OFF Case										No. of 1's
	DQ[7]	DQ[6]	DQ[5]	DQ[4]	DQ[3]	DQ[2]	DQ[1]	DQ[0]	DBI	
BL0	1	1	1	1	1	1	1	1	0	8
BL1	1	1	1	1	0	0	0	0	0	4
BL2	0	0	0	0	0	0	0	0	0	0
BL3	0	0	0	0	1	1	1	1	0	4
BL4	0	0	0	0	0	0	1	1	0	2
BL5	0	0	0	0	1	1	1	1	0	4
BL6	1	1	1	1	1	1	0	0	0	6
BL7	1	1	1	1	0	0	0	0	0	4
BL8	1	1	1	1	1	1	1	1	0	8
BL9	1	1	1	1	0	0	0	0	0	4
BL10	0	0	0	0	0	0	0	0	0	0
BL11	0	0	0	0	1	1	1	1	0	4
BL12	0	0	0	0	0	0	1	1	0	2
BL13	0	0	0	0	1	1	1	1	0	4
BL14	1	1	1	1	1	1	0	0	0	6
BL15	1	1	1	1	0	0	0	0	0	4
BL16	1	1	1	1	1	1	1	1	0	8
BL17	1	1	1	1	0	0	0	0	0	4
BL18	0	0	0	0	0	0	0	0	0	0
BL19	0	0	0	0	1	1	1	1	0	4
BL20	1	1	1	1	1	1	0	0	0	6
BL21	1	1	1	1	0	0	0	0	0	4
BL22	0	0	0	0	0	0	1	1	0	2
BL23	0	0	0	0	1	1	1	1	0	4
BL24	0	0	0	0	0	0	0	0	0	0
BL25	0	0	0	0	1	1	1	1	0	4
BL26	1	1	1	1	1	1	1	1	0	8
BL27	1	1	1	1	0	0	0	0	0	4
BL28	0	0	0	0	0	0	1	1	0	2
BL29	0	0	0	0	1	1	1	1	0	4
BL30	1	1	1	1	1	1	0	0	0	6
BL31	1	1	1	1	0	0	0	0	0	4
No. of 1's	16	16	16	16	16	16	16	16		

**Note:**

1. Same data pattern was applied to DQ[4], DQ[5], DQ[6], DQ[7] for reducing complexity for IDD4W/R pattern programming.



Table 111 - Data pattern for IDD4W (DBI on)

DBI ON Case										No. of 1's
	DQ[7]	DQ[6]	DQ[5]	DQ[4]	DQ[3]	DQ[2]	DQ[1]	DQ[0]	DBI	
BL0	0	0	0	0	0	0	0	0	1	1
BL1	1	1	1	1	0	0	0	0	0	4
BL2	0	0	0	0	0	0	0	0	0	0
BL3	0	0	0	0	1	1	1	1	0	4
BL4	0	0	0	0	0	0	1	1	0	2
BL5	0	0	0	0	1	1	1	1	0	4
BL6	0	0	0	0	0	0	1	1	1	3
BL7	1	1	1	1	0	0	0	0	0	4
BL8	0	0	0	0	0	0	0	0	1	1
BL9	1	1	1	1	0	0	0	0	0	4
BL10	0	0	0	0	0	0	0	0	0	0
BL11	0	0	0	0	1	1	1	1	0	4
BL12	0	0	0	0	0	0	1	1	0	2
BL13	0	0	0	0	1	1	1	1	0	4
BL14	0	0	0	0	0	0	1	1	1	3
BL15	1	1	1	1	0	0	0	0	0	4
BL16	0	0	0	0	0	0	1	1	1	3
BL17	1	1	1	1	0	0	0	0	0	4
BL18	0	0	0	0	0	0	1	1	0	2
BL19	0	0	0	0	1	1	1	1	0	4
BL20	0	0	0	0	0	0	0	0	0	0
BL21	0	0	0	0	1	1	1	1	0	4
BL22	0	0	0	0	0	0	0	0	1	1
BL23	1	1	1	1	0	0	0	0	0	4
BL24	0	0	0	0	0	0	1	1	0	2
BL25	0	0	0	0	1	1	1	1	0	4
BL26	0	0	0	0	0	0	1	1	1	3
BL27	1	1	1	1	0	0	0	0	0	4
BL28	0	0	0	0	0	0	0	0	1	1
BL29	1	1	1	1	0	0	0	0	0	4
BL30	0	0	0	0	0	0	0	0	0	0
BL31	0	0	0	0	1	1	1	1	0	4
No. of 1's	8	8	8	8	8	8	16	16	8	

**Note:**

1. DBI enabled burst.





Table 112 - Data pattern for IDD4R (DBI on)

DBI ON Case										No. of 1's
	DQ[7]	DQ[6]	DQ[5]	DQ[4]	DQ[3]	DQ[2]	DQ[1]	DQ[0]	DBI	
BL0	0	0	0	0	0	0	0	0	1	1
BL1	1	1	1	1	0	0	0	0	0	4
BL2	0	0	0	0	0	0	0	0	0	0
BL3	0	0	0	0	1	1	1	1	0	4
BL4	0	0	0	0	0	0	1	1	0	2
BL5	0	0	0	0	1	1	1	1	0	4
BL6	0	0	0	0	0	0	1	1	1	3
BL7	1	1	1	1	0	0	0	0	0	4
BL8	0	0	0	0	0	0	0	0	1	1
BL9	1	1	1	1	0	0	0	0	0	4
BL10	0	0	0	0	0	0	0	0	0	0
BL11	0	0	0	0	1	1	1	1	0	4
BL12	0	0	0	0	0	0	1	1	0	2
BL13	0	0	0	0	1	1	1	1	0	4
BL14	0	0	0	0	0	0	1	1	1	3
BL15	1	1	1	1	0	0	0	0	0	4
BL16	0	0	0	0	0	0	0	0	1	1
BL17	1	1	1	1	0	0	0	0	0	4
BL18	0	0	0	0	0	0	0	0	0	0
BL19	0	0	0	0	1	1	1	1	0	4
BL20	0	0	0	0	0	0	1	1	1	3
BL21	1	1	1	1	0	0	0	0	0	4
BL22	0	0	0	0	0	0	1	1	0	2
BL23	0	0	0	0	1	1	1	1	0	4
BL24	0	0	0	0	0	0	0	0	0	0
BL25	0	0	0	0	1	1	1	1	0	4
BL26	0	0	0	0	0	0	0	0	1	1
BL27	1	1	1	1	0	0	0	0	0	4
BL28	0	0	0	0	0	0	1	1	0	2
BL29	0	0	0	0	1	1	1	1	0	4
BL30	0	0	0	0	0	0	1	1	1	3
BL31	1	1	1	1	0	0	0	0	0	4
No. of 1's	8	8	8	8	8	8	16	16	8	



## 8.5.2 IDD Specifications

IDD values are for the entire operating voltage range, and all of them are for the entire standard range.

### IDD Specification Parameters and Operating Conditions (95°C) – Single Die

Notes: 1, 2 apply for all values

Parameter/Condition	Symbol	Power Supply	Data Rate (Mbps)				Unit	Notes
			3200	3733	4267	4267		
			95°C	95°C	95°C	70°C		
<b>Operating one bank active-precharge current:</b> tCK = tCKmin; tRC = tRCmin; CKE is HIGH; CS is LOW between valid commands; CA bus inputs are switching; Data bus inputs are stable ODT disabled	IDD01	VDD1	20	22	22	22	mA	
	IDD02	VDD2	40	45	63	63	mA	
	IDD0Q	VDDQ	0.5	0.5	0.5	0.5	mA	3
<b>Idle power-down standby current:</b> tCK = tCKmin; CKE is LOW; CS is LOW; All banks are idle; CA bus inputs are switching; Data bus inputs are stable ODT disabled	IDD2P1	VDD1	0.5	0.5	0.5	0.5	mA	
	IDD2P2	VDD2	3	3	3	3	mA	
	IDD2PQ	VDDQ	0.5	0.5	0.5	0.5	mA	3
<b>Idle power-down standby current with clock stop:</b> CK_t = LOW, CK_c = HIGH; CKE is LOW; CS is LOW; All banks are idle; CA bus inputs are stable; Data bus inputs are stable ODT disabled	IDD2PS1	VDD1	0.5	0.5	0.5	0.5	mA	
	IDD2PS2	VDD2	3	3	3	3	mA	
	IDD2PSQ	VDDQ	0.5	0.5	0.5	0.5	mA	3
<b>Idle non power-down standby current:</b> tCK = tCKmin; CKE is HIGH; CS is LOW; All banks are idle; CA bus inputs are switching; Data bus inputs are stable ODT disabled	IDD2N1	VDD1	0.6	0.6	0.6	0.6	mA	
	IDD2N2	VDD2	46	50	52	52	mA	
	IDD2NQ	VDDQ	0.5	0.5	0.5	0.5	mA	3
<b>Idle non power-down standby current with clock stopped:</b> CK_t = LOW, CK_c = HIGH; CKE is HIGH; CS is LOW; All banks are idle; CA bus inputs are stable; Data bus inputs are stable ODT disabled	IDD2NS1	VDD1	0.5	0.5	0.5	0.5	mA	
	IDD2NS2	VDD2	30	30	30	30	mA	
	IDD2NSQ	VDDQ	0.5	0.5	0.5	0.5	mA	3
<b>Active power-down standby current:</b> tCK = tCKmin; CKE is LOW; CS is LOW; One bank is active; CA bus inputs are switching; Data bus inputs are stable ODT disabled	IDD3P1	VDD1	3	3	4	4	mA	
	IDD3P2	VDD2	5	6	6	6	mA	
	IDD3PQ	VDDQ	0.5	0.5	0.5	0.5	mA	3



IDD Specification Parameters and Operating Conditions (95°C) – Single Die, Continued

Parameter/Condition	Symbol	Power Supply	Data Rate (Mbps)				Unit	Notes
			3200	3733	4267	4267		
			95°C	95°C	95°C	70°C		
<b>Active power-down standby current with clock stop:</b> CK <sub>t</sub> = LOW, CK <sub>c</sub> = HIGH; CKE is LOW; CS is LOW; One bank is active; CA bus inputs are stable; Data bus inputs are stable ODT disabled	I <sub>DD3PS1</sub>	V <sub>DD1</sub>	3	3	4	4	mA	
	I <sub>DD3PS2</sub>	V <sub>DD2</sub>	6	6	6	6	mA	
	I <sub>DD3PSQ</sub>	V <sub>DDQ</sub>	0.5	0.5	0.5	0.5	mA	4
<b>Active non power-down standby current:</b> tCK = tCK <sub>min</sub> ; CKE is HIGH; CS is LOW; One bank is active; CA bus inputs are switching; Data bus inputs are stable ODT disabled	I <sub>DD3N1</sub>	V <sub>DD1</sub>	3	4	4	4	mA	
	I <sub>DD3N2</sub>	V <sub>DD2</sub>	50	52	55	55	mA	
	I <sub>DD3NQ</sub>	V <sub>DDQ</sub>	0.5	0.5	0.5	0.5	mA	4
<b>Active non power-down standby current with clock stopped:</b> CK <sub>t</sub> = LOW, CK <sub>c</sub> = HIGH; CKE is HIGH; CS is LOW; One bank is active; CA bus inputs are stable; Data bus inputs are stable ODT disabled	I <sub>DD3NS1</sub>	V <sub>DD1</sub>	3	4	4	4	mA	
	I <sub>DD3NS2</sub>	V <sub>DD2</sub>	30	30	30	30	mA	
	I <sub>DD3NSQ</sub>	V <sub>DDQ</sub>	0.5	0.5	0.5	0.5	mA	4
<b>Operating burst READ current:</b> tCK = tCK <sub>min</sub> ; CS is LOW between valid commands; One bank is active; BL = 16 or 32; RL = RL (MIN); CA bus inputs are switching; 50% data change each burst transfer ODT disabled	I <sub>DD4R1</sub>	V <sub>DD1</sub>	4	4	4	4	mA	
	I <sub>DD4R2</sub>	V <sub>DD2</sub>	285	330	370	370	mA	
	I <sub>DD4RQ</sub>	V <sub>DDQ</sub>	140	140	140	140	mA	5, 7
<b>Operating burst WRITE current:</b> tCK = tCK <sub>min</sub> ; CS is LOW between valid commands; One bank is active; BL = 16 or 32; WL = WL <sub>min</sub> ; CA bus inputs are switching; 50% data change each burst transfer ODT disabled	I <sub>DD4W1</sub>	V <sub>DD1</sub>	3	4	4	4	mA	
	I <sub>DD4W2</sub>	V <sub>DD2</sub>	250	290	320	320	mA	
	I <sub>DD4WQ</sub>	V <sub>DDQ</sub>	0.5	0.5	0.5	0.5	mA	4
<b>All-bank REFRESH Burst current:</b> tCK = tCK <sub>min</sub> ; CKE is HIGH between valid commands; tRC = tRFC <sub>abmin</sub> ; Burst refresh; CA bus inputs are switching; Data bus inputs are stable ODT disabled	I <sub>DD51</sub>	V <sub>DD1</sub>	60	60	61	61	mA	
	I <sub>DD52</sub>	V <sub>DD2</sub>	80	83	85	85	mA	
	I <sub>DD5Q</sub>	V <sub>DDQ</sub>	0.5	0.5	0.5	0.5	mA	4



IDD Specification Parameters and Operating Conditions (95°C) – Single Die, Continued

Parameter/Condition	Symbol	Power Supply	Data Rate (Mbps)				Unit	Notes
			3200	3733	4267	4267		
			95°C	95°C	95°C	70°C		
<b>All-bank REFRESH Average current:</b> tCK = tCKmin; CKE is HIGH between valid commands; tRC = tREFI; CA bus inputs are switching; Data bus inputs are stable ODT disabled	I <sub>DD5AB1</sub>	V <sub>DD1</sub>	3	4	4	4	mA	
	I <sub>DD5AB2</sub>	V <sub>DD2</sub>	42	45	46	46	mA	
	I <sub>DD5ABQ</sub>	V <sub>DDQ</sub>	0.5	0.5	0.5	0.5	mA	4
<b>Per-bank REFRESH Average current:</b> tCK = tCKmin; CKE is HIGH between valid commands; tRC = tREFI/8; CA bus inputs are switching; Data bus inputs are stable ODT disabled	I <sub>DD5PB1</sub>	V <sub>DD1</sub>	5	6	6	6	mA	
	I <sub>DD5PB2</sub>	V <sub>DD2</sub>	42	45	46	46	mA	
	I <sub>DD5PBQ</sub>	V <sub>DDQ</sub>	0.5	0.5	0.5	0.5	mA	4
<b>Full Array Self Refresh Current:</b> CK <sub>t</sub> = LOW, CK <sub>c</sub> = HIGH; CKE is LOW; CA bus inputs are stable; Data bus inputs are stable; Maximum 1x Self Refresh Rate; ODT disabled	I <sub>DD61</sub>	V <sub>DD1</sub>	3	4	4	4	mA	6
	I <sub>DD62</sub>	V <sub>DD2</sub>	6	6	6	6	mA	6
	I <sub>DD6Q</sub>	V <sub>DDQ</sub>	0.5	0.5	0.5	0.5	mA	4, 6

**Notes:**

1. Published IDD values are the maximum of the distribution of the arithmetic mean.
2. ODT disabled: MR11[2:0] = 000<sub>b</sub>.
3. IDD current specifications are tested after the device is properly initialized.
4. Measured currents are the summation of V<sub>DDQ</sub> and V<sub>DD2</sub>.
5. Guaranteed by design with output load = 5pF and RON = 40Ω.
6. The 1x Self Refresh Rate is the rate at which the LPDDR4X device is refreshed internally during Self Refresh, before going into the elevated Temperature range.
7. I<sub>DD4Rq</sub> value is reference only. Typical value.
8. For all IDD measurements, V<sub>IHCKE</sub> = 0.8 x V<sub>DD2</sub>, V<sub>ILCKE</sub> = 0.2 x V<sub>DD2</sub>.
9. Dual Channel devices are specified in dual channel operation (both channels operating together).



## IDD Specification Parameters and Operating Conditions (105°C) – Single Die

Notes: 1, 2 apply for all values

Parameter/Condition	Symbol	Power Supply	Data Rate			Unit	Notes
			3200	3733	4267		
			105°C	105°C	105°C		
<b>Operating one bank active-precharge current:</b> tCK = tCKmin; tRC = tRCmin; CKE is HIGH; CS is LOW between valid commands; CA bus inputs are switching; Data bus inputs are stable ODT disabled	I <sub>DD01</sub>	V <sub>DD1</sub>	20	22	22	mA	
	I <sub>DD02</sub>	V <sub>DD2</sub>	40	45	63	mA	
	I <sub>DD0Q</sub>	V <sub>DDQ</sub>	0.5	0.5	0.5	mA	3
<b>Idle power-down standby current:</b> tCK = tCKmin; CKE is LOW; CS is LOW; All banks are idle; CA bus inputs are switching; Data bus inputs are stable ODT disabled	I <sub>DD2P1</sub>	V <sub>DD1</sub>	0.5	0.5	0.5	mA	
	I <sub>DD2P2</sub>	V <sub>DD2</sub>	3	3	3	mA	
	I <sub>DD2PQ</sub>	V <sub>DDQ</sub>	0.5	0.5	0.5	mA	3
<b>Idle power-down standby current with clock stop:</b> CK <sub>t</sub> = LOW, CK <sub>c</sub> = HIGH; CKE is LOW; CS is LOW; All banks are idle; CA bus inputs are stable; Data bus inputs are stable ODT disabled	I <sub>DD2PS1</sub>	V <sub>DD1</sub>	0.5	0.5	0.5	mA	
	I <sub>DD2PS2</sub>	V <sub>DD2</sub>	3	3	3	mA	
	I <sub>DD2PSQ</sub>	V <sub>DDQ</sub>	0.5	0.5	0.5	mA	3
<b>Idle non power-down standby current:</b> tCK = tCKmin; CKE is HIGH; CS is LOW; All banks are idle; CA bus inputs are switching; Data bus inputs are stable ODT disabled	I <sub>DD2N1</sub>	V <sub>DD1</sub>	0.6	0.6	0.6	mA	
	I <sub>DD2N2</sub>	V <sub>DD2</sub>	46	50	52	mA	
	I <sub>DD2NQ</sub>	V <sub>DDQ</sub>	0.5	0.5	0.5	mA	3
<b>Idle non power-down standby current with clock stopped:</b> CK <sub>t</sub> = LOW, CK <sub>c</sub> = HIGH; CKE is HIGH; CS is LOW; All banks are idle; CA bus inputs are stable; Data bus inputs are stable ODT disabled	I <sub>DD2NS1</sub>	V <sub>DD1</sub>	0.5	0.5	0.6	mA	
	I <sub>DD2NS2</sub>	V <sub>DD2</sub>	30	30	30	mA	
	I <sub>DD2NSQ</sub>	V <sub>DDQ</sub>	0.5	0.5	0.5	mA	3
<b>Active power-down standby current:</b> tCK = tCKmin; CKE is LOW; CS is LOW; One bank is active; CA bus inputs are switching; Data bus inputs are stable ODT disabled	I <sub>DD3P1</sub>	V <sub>DD1</sub>	3	3	4	mA	
	I <sub>DD3P2</sub>	V <sub>DD2</sub>	5	6	6	mA	
	I <sub>DD3PQ</sub>	V <sub>DDQ</sub>	0.5	0.5	0.5	mA	3



IDD Specification Parameters and Operating Conditions (105°C) – Single Die, Continued

Parameter/Condition	Symbol	Power Supply	Data Rate			Unit	Notes
			3200	3733	4267		
			105°C	105°C	105°C		
<b>Active power-down standby current with clock stop:</b> CK <sub>t</sub> = LOW, CK <sub>c</sub> = HIGH; CKE is LOW; CS is LOW; One bank is active; CA bus inputs are stable; Data bus inputs are stable ODT disabled	I <sub>DD3PS1</sub>	V <sub>DD1</sub>	3	3	4	mA	
	I <sub>DD3PS2</sub>	V <sub>DD2</sub>	6	6	6	mA	
	I <sub>DD3PSQ</sub>	V <sub>DDQ</sub>	0.5	0.5	0.5	mA	4
<b>Active non power-down standby current:</b> tCK = tCK <sub>min</sub> ; CKE is HIGH; CS is LOW; One bank is active; CA bus inputs are switching; Data bus inputs are stable ODT disabled	I <sub>DD3N1</sub>	V <sub>DD1</sub>	3	4	4	mA	
	I <sub>DD3N2</sub>	V <sub>DD2</sub>	50	52	55	mA	
	I <sub>DD3NQ</sub>	V <sub>DDQ</sub>	0.5	0.5	0.5	mA	4
<b>Active non power-down standby current with clock stopped:</b> CK <sub>t</sub> = LOW, CK <sub>c</sub> = HIGH; CKE is HIGH; CS is LOW; One bank is active; CA bus inputs are stable; Data bus inputs are stable ODT disabled	I <sub>DD3NS1</sub>	V <sub>DD1</sub>	3	4	4	mA	
	I <sub>DD3NS2</sub>	V <sub>DD2</sub>	30	30	30	mA	
	I <sub>DD3NSQ</sub>	V <sub>DDQ</sub>	0.5	0.5	0.5	mA	4
<b>Operating burst READ current:</b> tCK = tCK <sub>min</sub> ; CS is LOW between valid commands; One bank is active; BL = 16 or 32; RL = RL (MIN); CA bus inputs are switching; 50% data change each burst transfer ODT disabled	I <sub>DD4R1</sub>	V <sub>DD1</sub>	4	4	4	mA	
	I <sub>DD4R2</sub>	V <sub>DD2</sub>	285	330	370	mA	
	I <sub>DD4RQ</sub>	V <sub>DDQ</sub>	140	140	140	mA	5, 7
<b>Operating burst WRITE current:</b> tCK = tCK <sub>min</sub> ; CS is LOW between valid commands; One bank is active; BL = 16 or 32; WL = WL <sub>min</sub> ; CA bus inputs are switching; 50% data change each burst transfer ODT disabled	I <sub>DD4W1</sub>	V <sub>DD1</sub>	3	4	4	mA	
	I <sub>DD4W2</sub>	V <sub>DD2</sub>	250	290	320	mA	
	I <sub>DD4WQ</sub>	V <sub>DDQ</sub>	0.5	0.5	0.5	mA	4
<b>All-bank REFRESH Burst current:</b> tCK = tCK <sub>min</sub> ; CKE is HIGH between valid commands; tRC = tRFC <sub>abmin</sub> ; Burst refresh; CA bus inputs are switching; Data bus inputs are stable ODT disabled	I <sub>DD51</sub>	V <sub>DD1</sub>	60	60	61	mA	
	I <sub>DD52</sub>	V <sub>DD2</sub>	80	83	85	mA	
	I <sub>DD5Q</sub>	V <sub>DDQ</sub>	0.5	0.5	0.5	mA	4



IDD Specification Parameters and Operating Conditions (105°C) – Single Die, Continued

Parameter/Condition	Symbol	Power Supply	Data Rate			Unit	Notes
			3200	3733	4267		
			105°C	105°C	105°C		
<b>All-bank REFRESH Average current:</b> tCK = tCKmin; CKE is HIGH between valid commands; tRC = tREFI; CA bus inputs are switching; Data bus inputs are stable ODT disabled	I <sub>DD5AB1</sub>	V <sub>DD1</sub>	3	4	4	mA	
	I <sub>DD5AB2</sub>	V <sub>DD2</sub>	42	45	46	mA	
	I <sub>DD5ABQ</sub>	V <sub>DDQ</sub>	0.5	0.5	0.5	mA	4
<b>Per-bank REFRESH Average current:</b> tCK = tCKmin; CKE is HIGH between valid commands; tRC = tREFI/8; CA bus inputs are switching; Data bus inputs are stable ODT disabled	I <sub>DD5PB1</sub>	V <sub>DD1</sub>	5	6	6	mA	
	I <sub>DD5PB2</sub>	V <sub>DD2</sub>	42	45	46	mA	
	I <sub>DD5PBQ</sub>	V <sub>DDQ</sub>	0.5	0.5	0.5	mA	4
<b>Full Array Self Refresh Current:</b> CK <sub>t</sub> = LOW, CK <sub>c</sub> = HIGH; CKE is LOW; CA bus inputs are stable; Data bus inputs are stable; Maximum 1x Self Refresh Rate; ODT disabled	I <sub>DD61</sub>	V <sub>DD1</sub>	3	4	4	mA	6
	I <sub>DD62</sub>	V <sub>DD2</sub>	6	6	6	mA	6
	I <sub>DD6Q</sub>	V <sub>DDQ</sub>	0.5	0.5	0.5	mA	4, 6

**Notes:**

1. Published IDD values are the maximum of the distribution of the arithmetic mean.
2. ODT disabled: MR11[2:0] = 000<sub>b</sub>.
3. IDD current specifications are tested after the device is properly initialized.
4. Measured currents are the summation of V<sub>DDQ</sub> and V<sub>DD2</sub>.
5. Guaranteed by design with output load = 5pF and RON = 40Ω.
6. The 1x Self Refresh Rate is the rate at which the LPDDR4 device is refreshed internally during Self Refresh, before going into the elevated Temperature range.
7. I<sub>DD4RQ</sub> value is reference only. Typical value.
8. For all IDD measurements, VIHCKE = 0.8 x V<sub>DD2</sub>, VILCKE = 0.2 x V<sub>DD2</sub>.
9. Dual Channel devices are specified in dual channel operation (both channels operating together).



## 8.6 Electrical Characteristics and AC Timing

### 8.6.1 Clock Specification

The jitter specified is a random jitter meeting a Gaussian distribution. Input clocks violating the min/max values may result in malfunction of the LPDDR4X device.

#### 8.6.1.1 Definition for tCK(avg) and nCK

tCK(avg) is calculated as the average clock period across any consecutive 200 cycle window, where each clock period is calculated from rising edge to rising edge.

$$tCK(avg) = \left[ \sum_{j=1}^N tCK_j \right] / N$$

where  $N = 200$

Unit 'tCK(avg)' represents the actual clock average tCK(avg) of the input clock under operation. Unit 'nCK' represents one clock cycle of the input clock, counting the actual clock edges.

tCK(avg) may change by up to  $\pm 1\%$  within a 100 clock cycle window, provided that all jitter and timing specs are met.

#### 8.6.1.2 Definition for tCK(abs)

tCK(abs) is defined as the absolute clock period, as measured from one rising edge to the next consecutive rising edge.

tCK(abs) is not subject to production test.





### 8.6.1.3 Definition for tCH(avg) and tCL(avg)

tCH(avg) is defined as the average high pulse width, as calculated across any consecutive 200 high pulses.

$$tCH(avg) = \left[ \sum_{j=1}^N tCH_j \right] / (N \times tCK(avg))$$

where  $N = 200$

tCL(avg) is defined as the average low pulse width, as calculated across any consecutive 200 low pulses.

$$tCL(avg) = \left[ \sum_{j=1}^N tCL_j \right] / (N \times tCK(avg))$$

where  $N = 200$

### 8.6.1.4 Definition for tCH(abs) and tCL(abs)

tCH(abs) is the absolute instantaneous clock high pulse width, as measured from one rising edge to the following falling edge.

tCL(abs) is the absolute instantaneous clock low pulse width, as measured from one falling edge to the following rising edge.

Both tCH(abs) and tCL(abs) are not subject to production test.

### 8.6.1.5 Definition for tJIT(per)

tJIT(per) is the single period jitter defined as the largest deviation of any signal tCK from tCK(avg).

tJIT(per) = Min/max of {tCK<sub>i</sub> - tCK(avg) where i = 1 to 200}.

tJIT(per).act is the actual clock jitter for a given system.

tJIT(per).allowed is the specified allowed clock period jitter.

tJIT(per) is not subject to production test.

### 8.6.1.6 Definition for tJIT(cc)

tJIT(cc) is defined as the absolute difference in clock period between two consecutive clock cycles.

tJIT(cc) = Max of {|tCK<sub>i+1</sub> - tCK<sub>i</sub>|}.

tJIT(cc) defines the cycle to cycle jitter.

tJIT(cc) is not subject to production test.



## 8.6.2 Clock AC Timing

Table 113 - Clock AC Timing

Parameter	Symbol	Min/ Max	Data Rate					Unit	Note
			1600	2400	3200	3733	4267		
Average clock period	tCK(avg)	Min	1.25	0.833	0.625	0.535	0.468	nS	
		Max	100	100	100	100	100		
Average High pulse width	tCH(avg)	Min	0.46	0.46	0.46	TBD	TBD	tCK(avg)	
		Max	0.54	0.54	0.54	TBD	TBD		
Average Low pulse width	tCL(avg)	Min	0.46	0.46	0.46	TBD	TBD	tCK(avg)	
		Max	0.54	0.54	0.54	TBD	TBD		
Absolute clock period	tCK(abs)	Min	tCK(avg)min + tJIT(per)min					nS	
		Max	-						
Absolute High clock pulse width	tCH(abs)	Min	0.43	0.43	0.43	TBD	TBD	tCK(avg)	
		Max	0.57	0.57	0.57	TBD	TBD		
Absolute Low clock pulse width	tCL(abs)	Min	0.43	0.43	0.43	TBD	TBD	tCK(avg)	
		Max	0.57	0.57	0.57	TBD	TBD		
Clock period jitter	tJIT(per)	Min	-70	-50	-40	-	-	pS	
		Max	70	50	40	TBD	TBD		
Maximum Clock Jitter between consecutive cycles	tJIT(cc)	Min	-	-	-	-	-	pS	
		Max	140	100	80	TBD	TBD		

**Note:**

- All parts list in section 3 order information table will not guarantee to meet functional and AC specification if the tCK(avg) out of range mentioned in above table.

## 8.6.3 Temperature Derating for AC timing

Table 114 - Temperature Derating AC Timing

Parameter	Symbol	Min/ Max	Data Rate							Unit
			533	1066	1600	2133	2667	3200	3733	
Temperature Derating*1										
DQS output access time from CK_t/CK_c (derated)	tDQSCK	Max	3600							pS
RAS-to-CAS delay (derated)	tRCD	Min	tRCD + 1.875							nS
ACTIVATE-to- ACTIVATE command period (derated)	tRC	Min	tRC + 3.75							nS
			nS							
Row active time (derated)	tRAS	Min	tRAS + 1.875							nS
Row precharge time (derated)	tRP	Min	tRP + 1.875							nS
Active bank A to active bank B (derated)	tRRD	Min	tRRD + 1.875							nS

**Note:**

- At higher temperatures (>85°C), AC timing derating may be required. If derating is required the LPDDR4-SDRAM will set MR4 OP[2:0]=110<sub>b</sub>.



#### 8.6.4 CA Rx voltage and timing

The command and address(CA) including CS input receiver compliance mask for voltage and timing is shown in Figure 166. All CA, CS signals apply the same compliance mask and operate in single data rate mode.

The CA input receiver mask for voltage and timing is shown in Figure 167 is applied across all CA pins. The receiver mask (Rx Mask) defines the area that the input signal must not encroach in order for the DRAM input receiver to be expected to be able to successfully capture a valid input signal; it is not the valid data-eye.

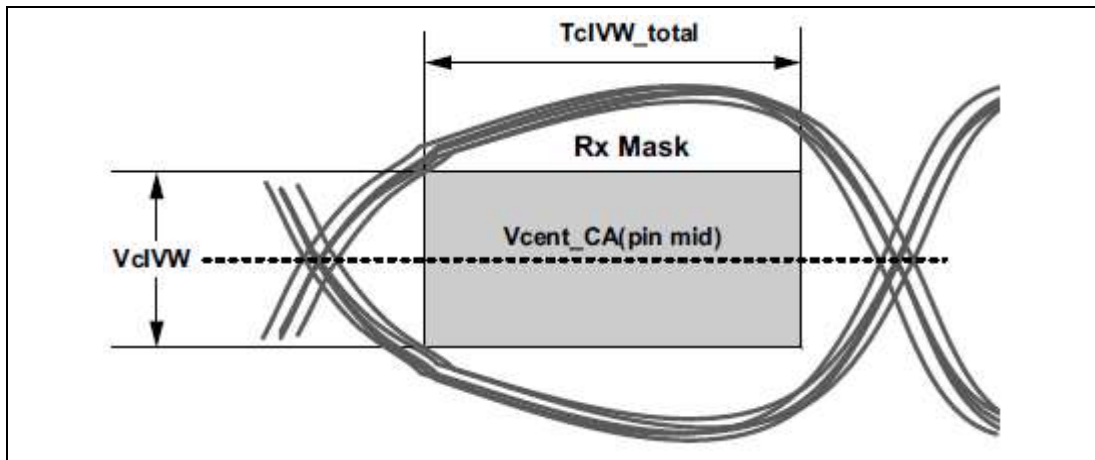

Figure 166 - CA Receiver (Rx) Mask

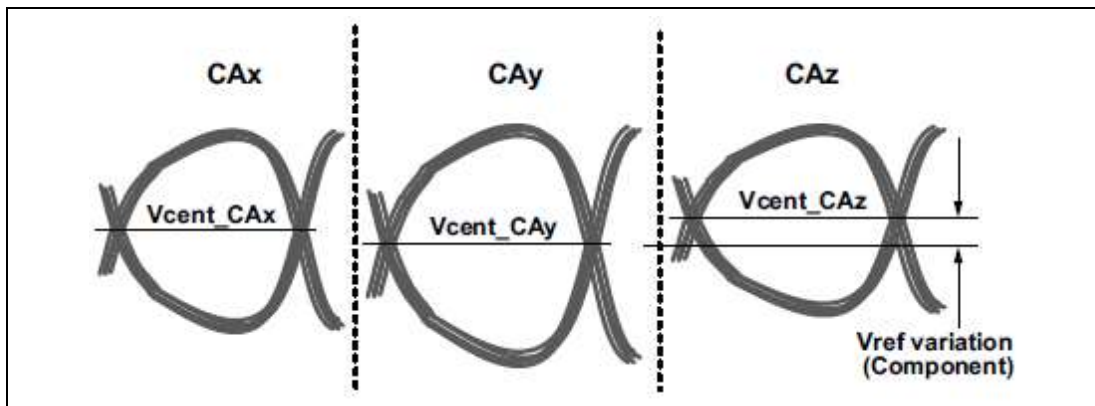
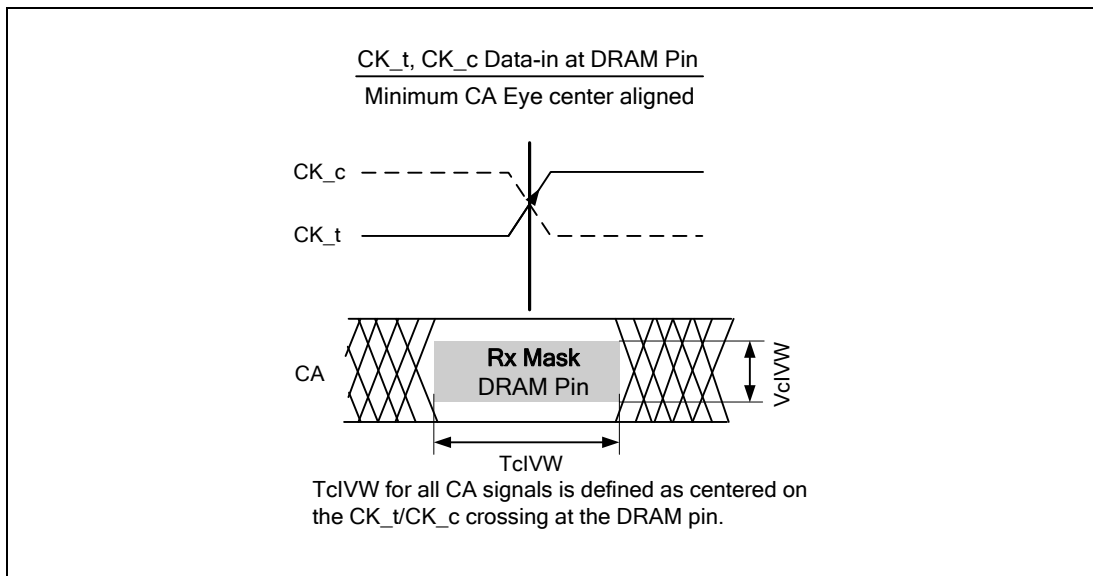

Figure 167 - Across pin VREFCA voltage variation

$V_{cent\_CA}(\text{pin mid})$  is defined as the midpoint between the largest  $V_{cent\_CA}$  voltage level and the smallest  $V_{cent\_CA}$  voltage level across all CA and CS pins for a given DRAM component. Each CA  $V_{cent}$  level is defined by the center, i.e., widest opening, of the cumulative data input eye as depicted in Figure 167. This clarifies that any DRAM component level variation must be accounted for within the DRAM CA Rx mask.

The component level VREF will be set by the system to account for Ron and ODT settings.



**Figure 168 - DCA Timings at the DRAM Pins**

All of the timing terms in Figure 168 are measured from the CK\_t/CK\_c to the center (midpoint) of the TcIVW window taken at the VcIVW\_total voltage levels centered around Vcent\_CA(pin mid).

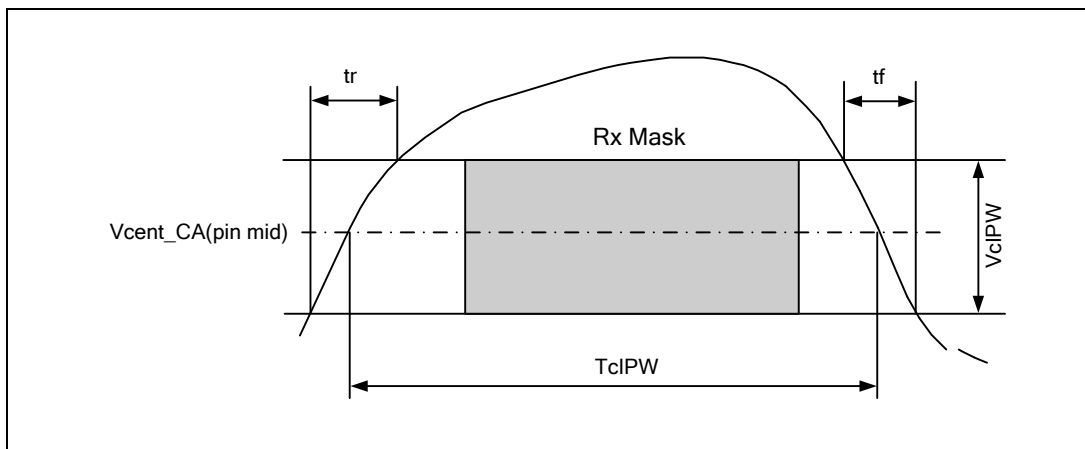

**Note:**

1.  $SRIN\_cIVW = VcIVW\_Total / (tr \text{ or } tf)$ , signal must be monotonic within tr and tf range.

**Figure 169 - CA TcIPW and SRIN\_cIVW definition (for each input pulse)**

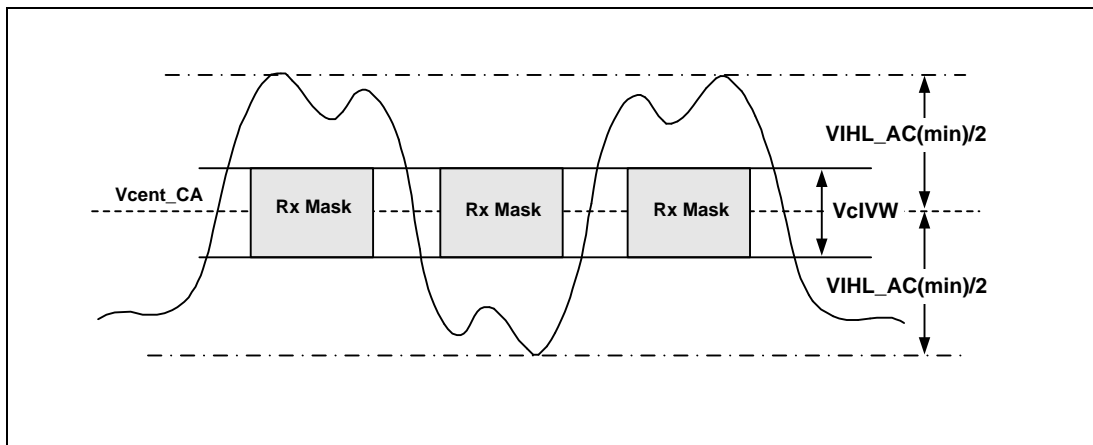

**Figure 170 - CA VIH\_L\_AC definition (for each input pulse)**



Table 115 - DRAM CMD/ADR, CS

\* Unit UI=tCK(avg)min

Symbol	Parameter	Min/ Max	Data Rate					Unit	Notes
			1333* <sup>A</sup>	1600/1867	3200	3733	4267		
VcIVW	Rx Mask voltage - p-p	Min	-	-	-	-	-	mV	1,2,3
		Max	175	175	155	150	145		
TcIVW	Rx timing window	Min	0.3	0.3	0.3	0.3	0.3	UI*	1,2,3
		Max	-	-	-	-	-		
VIHL_AC	CA AC input pulse amplitude pk-pk	Min	210	210	190	180	180	mV	4,7
		Max	-	-	-	-	-		
TcIPW	CA input pulse width	Min	0.55	0.55	0.6	0.6	0.6	UI*	5
		Max							
SRIN_cIVW	Input Slew Rate over VcIVW	Min	1	1	1	1	1	V/nS	6
		Max	7	7	7	7	7		

A. The following Rx voltage and absolute timing requirements apply for DQ operating frequencies at or below 1333 for all speed bins. For example the TcIVW(pS) = 450pS at or below 1333 operating frequencies.

**Notes:**

1. CA Rx mask voltage and timing parameters at the pin including voltage and temperature drift.
2. Rx mask voltage VcIVW total(max) must be centered around Vcent\_CA(pin mid).
3. Vcent\_CA must be within the adjustment range of the CA internal VREF.
4. CA only input pulse signal amplitude into the receiver must meet or exceed VIHL AC at any point over the total UI. No timing requirement above level. VIHL AC is the peak to peak voltage centered around Vcent\_CA(pin mid) such that VIHL\_AC/2 min must be met both above and below Vcent\_CA.
5. CA only minimum input pulse width defined at the Vcent\_CA(pin mid).
6. Input slew rate over VcIVW Mask centered at Vcent\_CA(pin mid).
7. VIHL\_AC does not have to be met when no transitions are occurring.



8.6.5 DRAM Data Timing

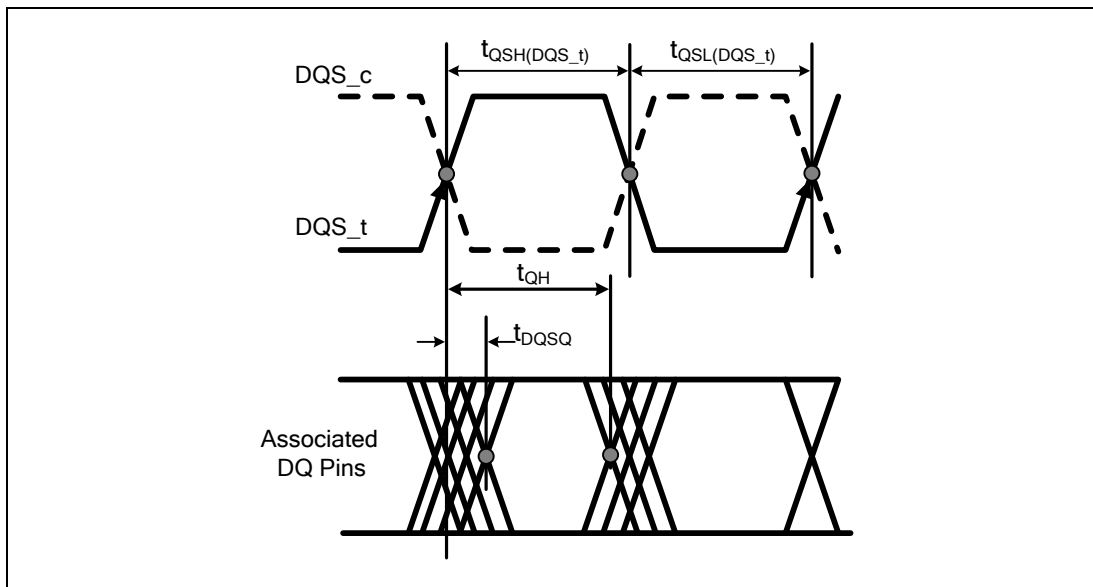

Figure 171 - Read data timing definitions  $t_{QH}$  and  $t_{DQSQ}$  across all DQ signals per DQS group

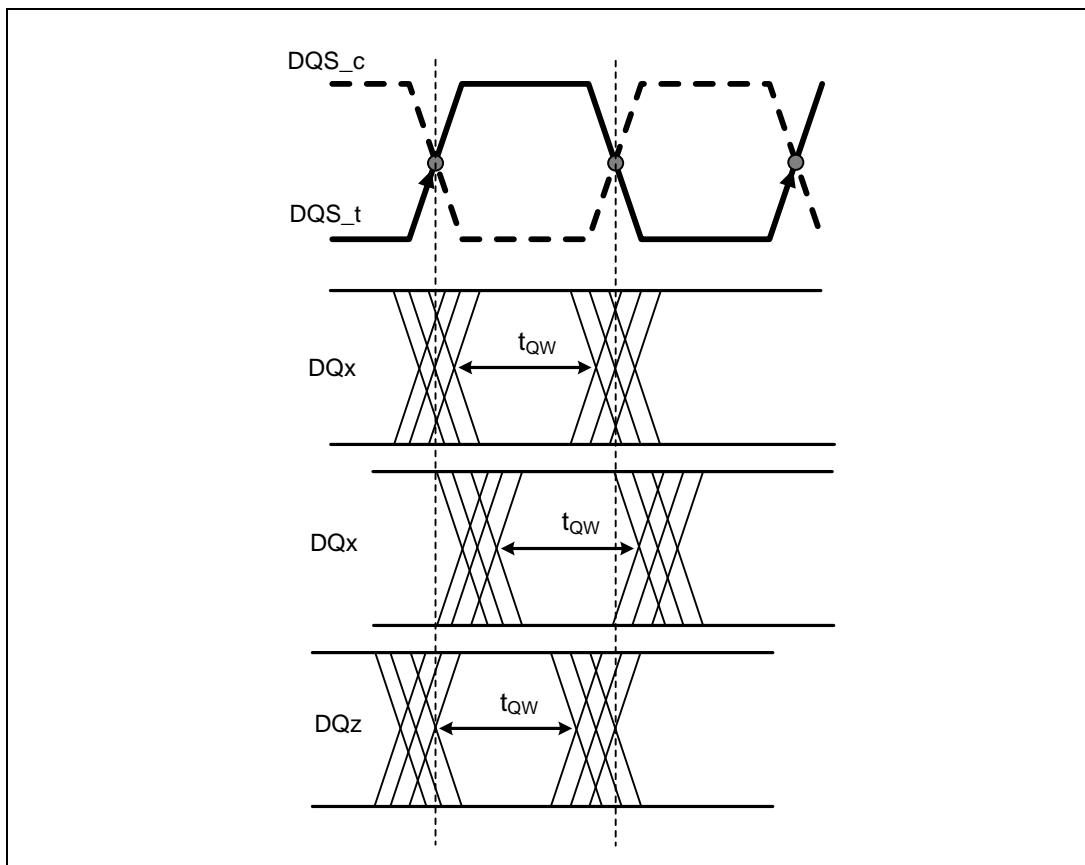

Figure 172 - Read data timing  $t_{QW}$  valid window defined per DQ signal



Table 116 - Read output timing

\* Unit UI=tCK(avg)min/2

Parameter	Symbol	Min/ Max	Data Rate					Unit	Notes
			1600/1867	2133/2400	3200	3733	4267		
Data Timing									
DQS_t, DQS_c to DQ Skew total, per group, per access (DBI-Disabled)	tDQSQ	Min	-					UI	
		Max	0.18						
DQ output hold time total from DQS_t, DQS_c (DBI-Disabled)	tQH	Min	min(tQSH, tQSL)					UI	
		Max	-						
DQ output window time total, per pin (DBI-Disabled)	tQW_total	Min	0.75	0.73	0.7	0.7	0.7	UI	3
		Max	-	-	-	-	-		
DQ output window time deterministic, per pin (DBI-Disabled)	tQW_dj	Min	TBD					UI	2, 3
		Max	-						
DQS_t, DQS_c to DQ Skew total, per group, per access (DBI-Enabled)	tDQSQ_DBI	Min	-					UI	
		Max	0.18						
DQ output hold time total from DQS_t, DQS_c (DBI-Enabled)	tQH_DBI	Min	min(tQSH_DBI, tQSL_DBI)					UI	
		Max	-						
DQ output window time total, per pin (DBI-Enabled)	tQW_total_DBI	Min	0.75	0.73	0.7	0.7	0.7	UI	3
		Max	-	-	-	-	-		
Data Strobe Timing									
DQS_t, DQS_c differential output low time (DBI-Disabled)	tQSL	Min	tCL(abs)-0.05					tCK(avg)	3, 4
		Max	-						
DQS_t, DQS_c differential output high time (DBI-Disabled)	tQSH	Min	tCH(abs)-0.05					tCK(avg)	3, 5
		Max	-						
DQS_t, DQS_c differential output low time (DBI-Enabled)	tQSL_DBI	Min	tCL(abs)-0.045					tCK(avg)	4, 6
		Max	-						
DQS_t, DQS_c differential output high time (DBI-Enabled)	tQSH_DBI	Min	tCH(abs)-0.045					tCK(avg)	5, 6
		Max	-						

**Notes:**

1. The deterministic component of the total timing.
2. This parameter will be characterized and guaranteed by design.
3. This parameter is function of input clock jitter. These values assume the min tCH(abs) and tCL(abs). When the input clock jitter min tCH(abs) and tCL(abs) is 0.44 or greater of tCK(avg) the min value of tQSL will be tCL(abs)-0.04 and tQSH will be tCH(abs)-0.04.
4. tQSL describes the instantaneous differential output low pulse width on DQS\_t - DQS\_c, as it measured the next rising edge from an arbitrary falling edge.
5. tQSH describes the instantaneous differential output high pulse width on DQS\_t - DQS\_c, as it measured the next rising edge from an arbitrary falling edge.
6. This parameter is function of input clock jitter. These values assume the min tCH(abs) and tCL(abs). When the input clock jitter min tCH(abs) and tCL(abs) is 0.44 or greater of tCK(avg) the min value of tQSL will be tCL(abs)-0.04 and tQSH will be tCH(abs)-0.04.





### 8.6.6 DQ Rx voltage and timing

The DQ input receiver mask for voltage and timing is shown Figure 173 is applied per pin. The "total" mask ( $V_{dIVW\_total}$ ,  $T_{diVW\_total}$ ) defines the area the input signal must not encroach in order for the DQ input receiver to successfully capture an input signal. The mask is a receiver property and it is not the valid data-eye.

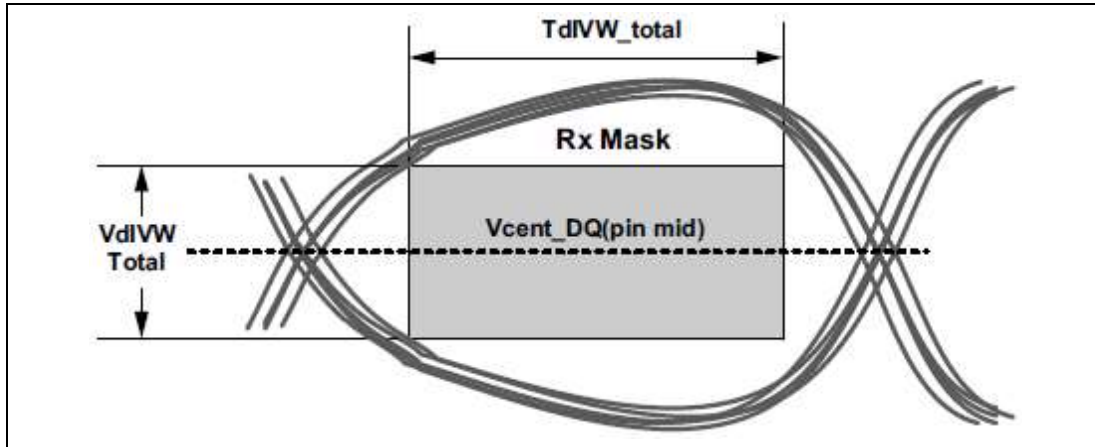

Figure 173 - DQ Receiver (Rx) mask

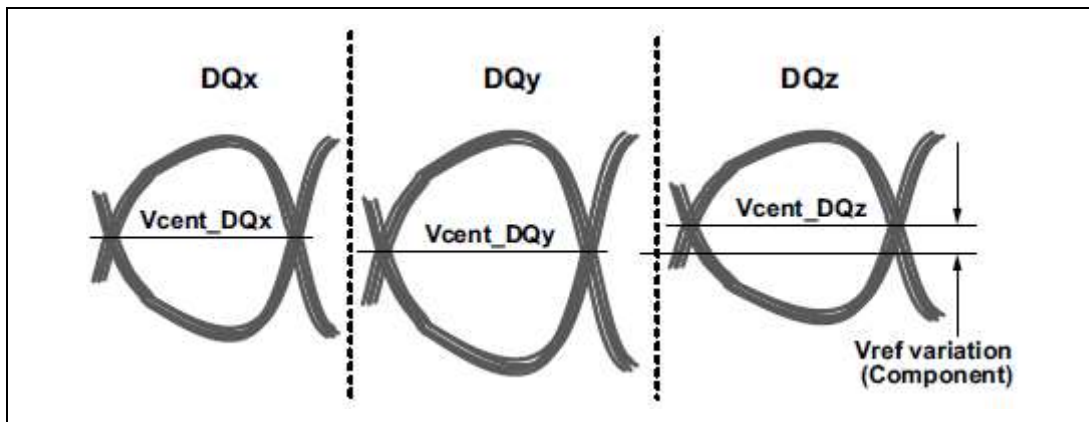

Figure 174 - Across pin VREF DQ voltage variation

$V_{cent\_DQ}(pin\_mid)$  is defined as the midpoint between the largest  $V_{cent\_DQ}$  voltage level and the smallest  $V_{cent\_DQ}$  voltage level across all DQ pins for a given DRAM component. Each DQ  $V_{cent}$  is defined by the center, i.e., widest opening, of the cumulative data input eye as depicted in Figure 174. This clarifies that any DRAM component level variation must be accounted for within the DRAM Rx mask. The component level  $V_{ref}$  will be set by the system to account for  $R_{on}$  and ODT settings.



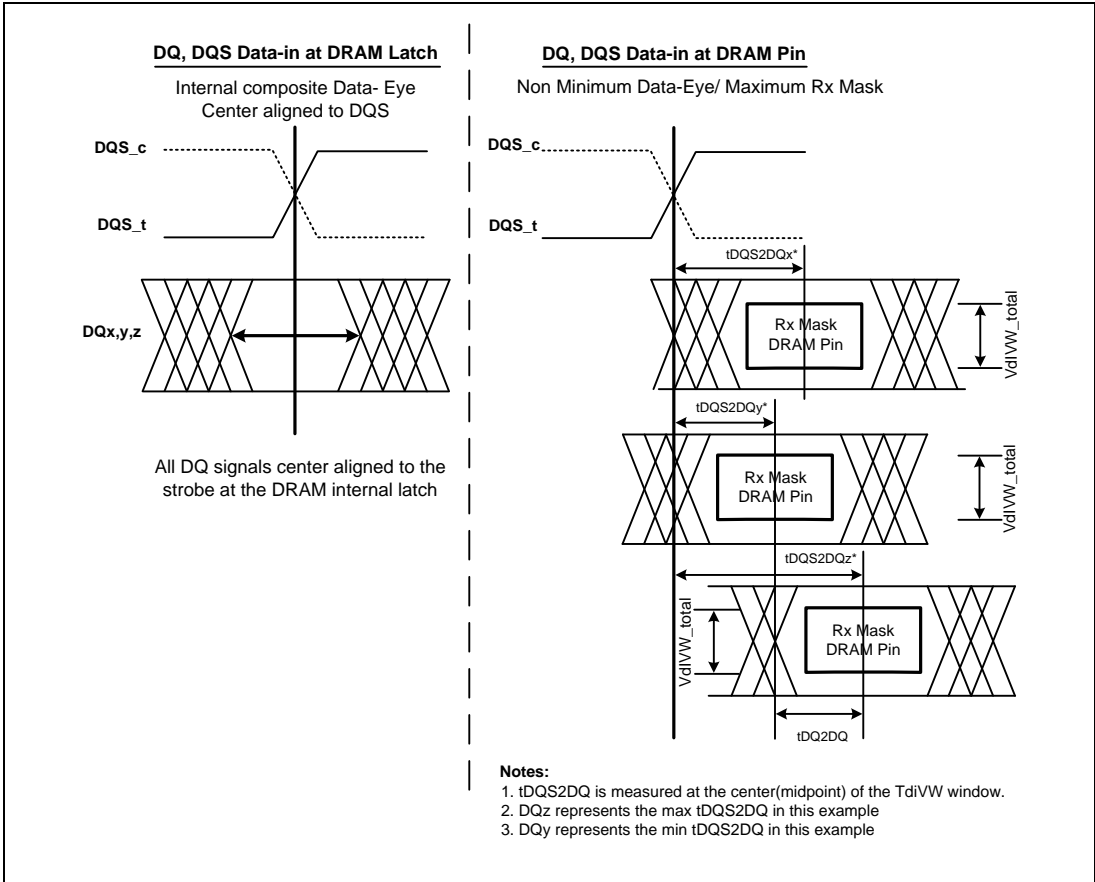
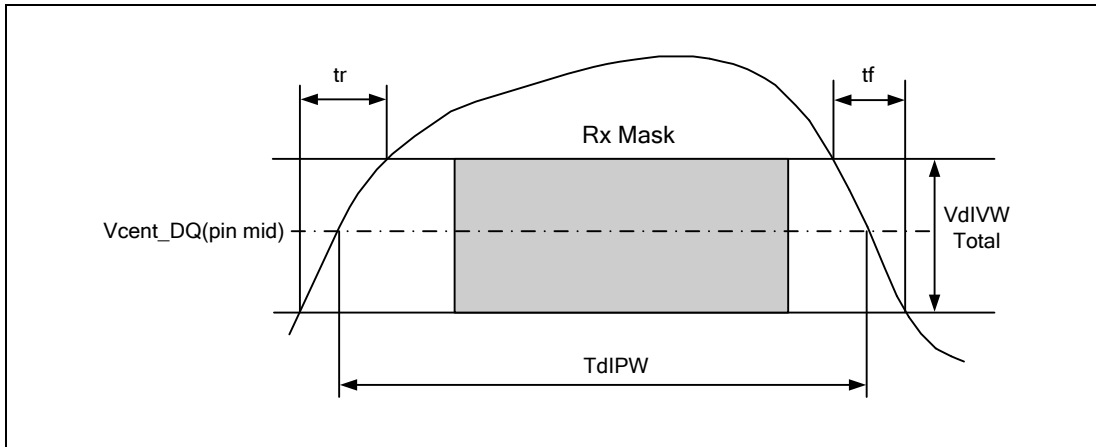

Figure 175 - DQ to DQS tDQS2DQ and tDQ2DQ Timings at the DRAM pins referenced from the internal latch



**Note:**

1.  $SRIN\_dIVW = VdIVW\_Total / (tr \text{ or } tf)$ , signal must be monotonic within  $tr$  and  $tf$  range.

**Figure 176 - DQ TdIPW and SRIN\_dIVW definition (for each input pulse)**

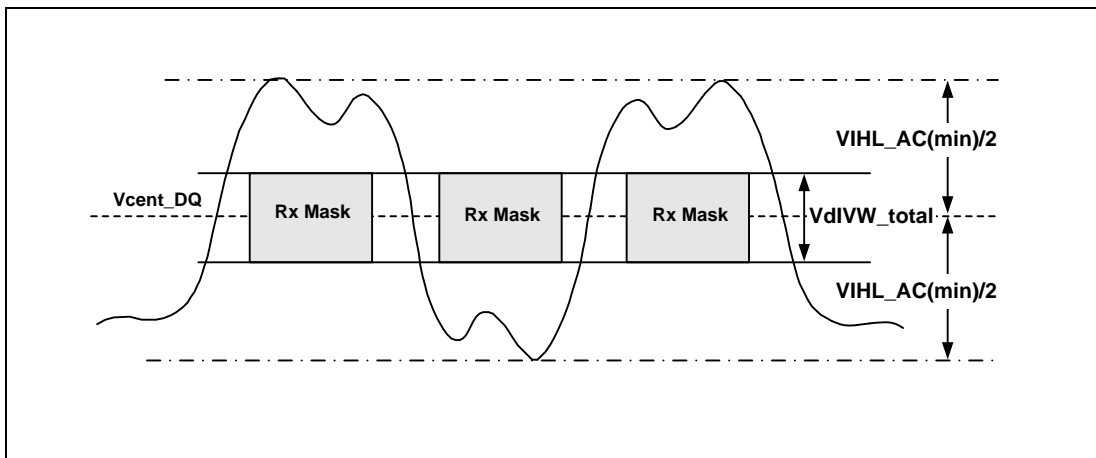

**Figure 177 - DQ VIH\_L\_AC definition (for each input pulse)**



Table 117 - DRAM DQs In Receive Mode

\* UI=tCK(avg)min/2

Parameter	Symbol	Min/ Max	Data Rate					Unit	Notes
			1600/1867 <sup>*A</sup>	2133/2400	3200	3733	4267		
Rx Mask voltage - peak-to-peak total	VdIVW_total	Min	-					mV	1,2,3,4
		Max	140	140	140	130	120		
Rx timing window total (At VdIVW voltage levels)	TdIVW_total	Min	-					UI*	1,2,4
		Max	0.22	0.22	0.25	0.25	0.25		
Rx timing window 1 bit toggle (At VdIVW voltage levels)	TdIVW_1bit	Min	-					UI*	1,2,4,12
		Max	TBD						
DQ AC input pulse amplitude peak-to-peak	VIHL_AC	Min	180	180	180	180	170	mV	5,13
		Max	-						
Input pulse width (At Vcent_DQ)	TdIPW DQ	Min	0.45					UI*	6
		Max							
DQ to DQS offset	tDQS2DQ	Min	200					pS	7
		Max	800						
DQ to DQ offset	tDQ2DQ	Min	-					pS	8
		Max	30						
DQ to DQS offset temperature variation	tDQS2DQ_temp	Min	-					pS/°C	9
		Max	0.6						
DQ to DQS offset voltage variation	tDQS2DQ_volt	Min	-					pS/50 mV	10
		Max	33						
Input Slew Rate over VdIVW_total	SRIN_dIVW	Min	1					V/nS	11
		Max	7						
DQ to DQS offset rank to rank variation	tDQS2DQ_rank2rank	Min	-					pS	14,15,16
		Max	200						

A. The Rx voltage and absolute timing requirements apply for all DQ operating frequencies at or below 1600 for all speed bins. For example TdIVW\_total(pS) = 137.5pS at or below 1600 operating frequencies

**Notes:**

- Data Rx mask voltage and timing parameters are applied per pin and includes the DRAM DQ to DQS voltage AC noise impact for frequencies >20 MHz and max voltage of 45mv pk-pk from DC-20MHz at a fixed temperature on the package. The voltage supply noise must comply with the component Min-Max DC operating conditions.
- The design specification is a BER <TBD. The BER will be characterized and extrapolated if necessary using a dual-dirac method.
- Rx mask voltage VdIVW total (max) must be centered around Vcent\_DQ (pin\_mid).
- Vcent\_DQ must be within the adjustment range of the DQ internal VREF.
- DQ only input pulse amplitude into the receiver must meet or exceed VIHL AC at any point over the total UI. No timing requirement above level. VIHL AC is the peak to peak voltage centered around Vcent\_DQ (pin\_mid) such that VIHL\_AC/2 min must be met both above and below Vcent\_DQ.
- DQ only minimum input pulse width defined at the Vcent\_DQ (pin\_mid).
- DQ to DQS offset is within byte from DRAM pin to DRAM internal latch. Includes all DRAM process, voltage and temperature variation.
- DQ to DQ offset defined within byte from DRAM pin to DRAM internal latch for a given component.
- TDQS2DQ max delay variation as a function of temperature.
- TDQS2DQ max delay variation as a function of the DC voltage variation for VDDQ and VDD2. It includes the VDDQ and VDD2 AC noise impact for frequencies > 20MHz and max voltage of 45mV pk-pk from DC-20MHz at a fixed temperature on the package. For tester measurement VDDQ = VDD2 is assumed.
- Input slew rate over VdIVW Mask centered at Vcent\_DQ (pin\_mid).
- Rx mask defined for a one pin toggling with other DQ signals in a steady state.
- VIHL\_AC does not have to be met when no transitions are occurring.
- The same voltage and temperature are applied to tDQS2DQ\_rank2rank.
- tDQS2DQ\_rank2rank parameter is applied to multi-ranks per byte lane within a package consisting of the same design dies.
- tDQS2DQ\_rabk2rank support was added to JESD209-4B, some older devices designed to support.



9. PACKAGE DIMENSIONS

Package Outline WFBGA 200 Ball (10x14.5 mm<sup>2</sup>, Ball pitch: 0.8 x 0.65mm)

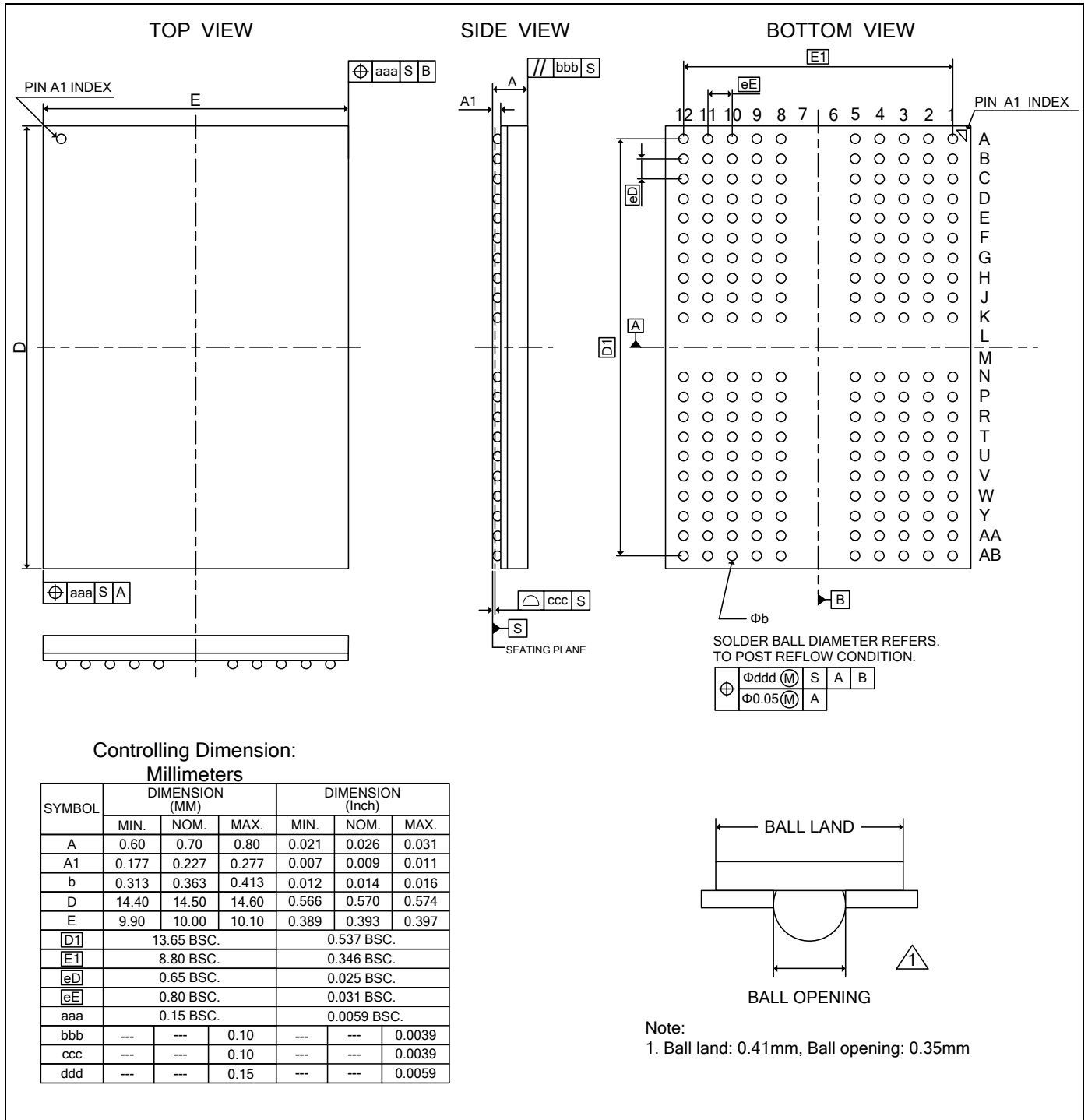



## 10. REVISION HISTORY

VERSION	DATE	PAGE	DESCRIPTION
A01-001	Jul. 02, 2019	All	Initial formal datasheet
A01-002	Jul. 23, 2019	94	Revise Table 33 note 12, DBI not apply during normal MRR
		146	Table 54 remove supporting the two physical registers for Burst Length: MR1 OP[1:0]
A01-003	Sep. 18, 2019	5	Add six of -40°C~105°C SDP/DDP part number
		212	Update 8.3.2.5 Differential Input Cross Point Voltage descriptions with figure 153 and add note 3~5 of Table 94
		233~235	Add 105°C IDDX spec values

*Please note that all data and specifications are subject to change without notice.  
All the trademarks of products and companies mentioned in this datasheet belong to their respective owners.*

*Publication Release Date: Sep. 18, 2019  
Revision: A01-003*