

uUSB-PA5

uUSB-PA5
uUSB-PA5-II



Datasheet

Copyright © 2023 4D Systems

Content may change at any time. Please refer to the resource centre for latest documentation.

Contents

1. Description	3
2. Module Compatibility	4
3. Features	4
4. Pin Configuration and Summary	5
5. Typical Applications	6
6. Mechanical Dimensions	7
7. Schematic Diagram HW REV 1.0	8
8. Schematic Diagram HW REV 3.0	9
9. Revision History	10
10. Ordering Information	10

1. Description

The micro USB Programming Adaptor is a USB to TTL UART bridge converter which is simple, cost-effective, very small and easy to use.

There are 2 versions of the micro USB Programming Adaptor, the uUSB-PA5 and the uUSB-PA5-II.

They both use a mini-B type USB connector to connect to your PC. The uUSB-PA5 is based on the FTDI FT232RQ USB to Serial Bridge IC from FTDI Chip, while the uUSB-PA5-II is based on the SiLabs CP2104 USB to Serial Bridge IC from Silicon Labs.

From the perspective of programming 4D Systems modules, both the uUSB-PA5 and uUSB-PA5-II operate in the same way.

They provide the User with multi-baud rate serial data and access to additional signals such as flow control in a convenient 10-pin 2.54mm (0.1") pitch Dual-In-Line package.

The main 5-pin interface is a standard 2.54mm (0.1") pitch female header, designed to connect directly to a majority of the 4D Systems modules.

The uUSB-PA5 and uUSB-PA5-II are ideal for prototypes or production.

RX and TX signals are both 3.3V and 5V tolerant.

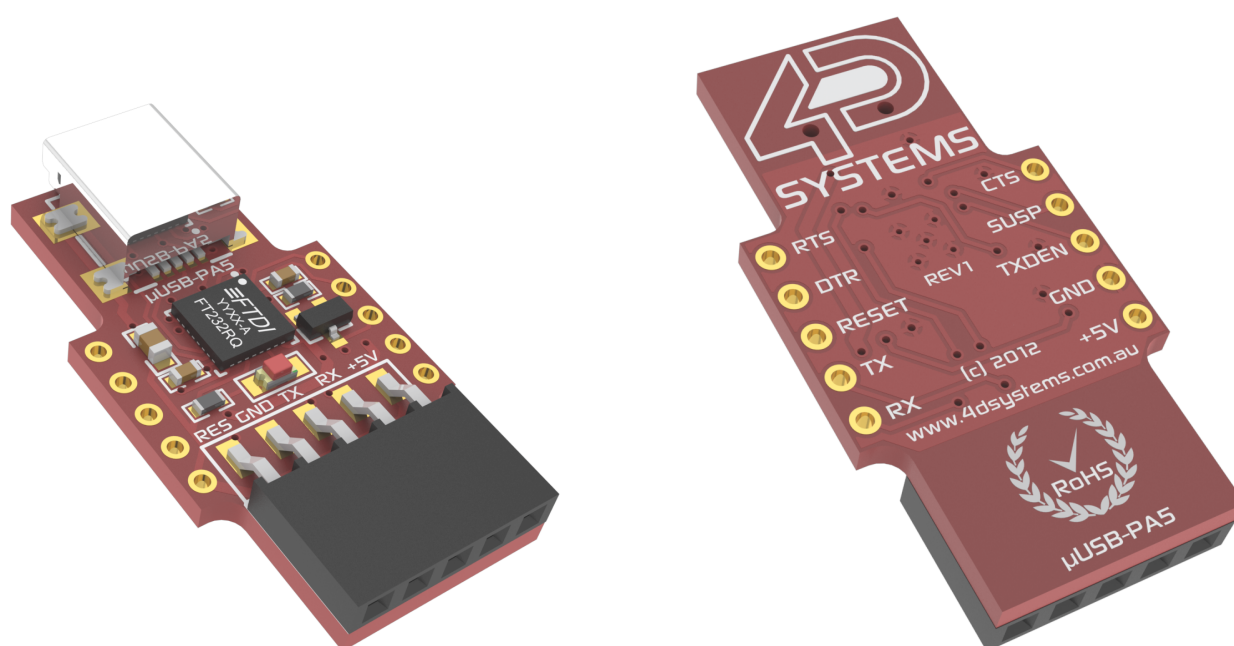

2. Module Compatibility

The uUSB-PA5 was designed in 2012. The uUSB-PA5-II was designed in 2015 to replace the uUSB-PA5.

While a large range of 4D Systems modules is compatible with these programming adaptors, some are not, for mechanical reasons.

The following is a small list of known modules that are not compatible with the uUSB-PA5/PA5-II.

- uLCD-28PT (note, this is not the PTU)
- uLCD-32PT (note, this is not the PTU)

Please use the 4D Programming cable instead, or simply connect the 5-way cable that ships with each module, between the uUSB-PA5/PA5-II and the display module, which overcomes this compatibility issue.

3. Features

- USB 2.0 compliant Full Speed 12Mbps maximum speed, Suspend supported.
- Hardware or Xon/Xoff handshaking supported, 300bps to 3Mbps (uUSB-PA5), 300bps to 2Mbps (uUSB-PA5-II)
- UART supports 7 or 8 data bits, 1-2 Stop bits, odd/even/mark/space and no parity (uUSB-PA5). 5, 6, 7, 8 data bits, 1, 1.5, 2 stop bits, odd/even/mark/space and no parity (uUSB-PA5-II).
- Power on reset circuit
- Virtual COM port drivers allow operation with existing COM port PC applications
- Supports Windows 2000 and above, MAC (OSX-8 and above) and Linux (2.4 kernels and above)
- USB powered
- -40 to +85 degrees Celsius temp range
- Small size, 33.7mm x 17.3mm
- Traffic/Operation LED indicates board status
- Additional flow control and features are available for the user to solder, using standard 2.54mm (0.1") pitch through holes along each side of the PCB.
- RoHS Compliant

4. Pin Configuration and Summary

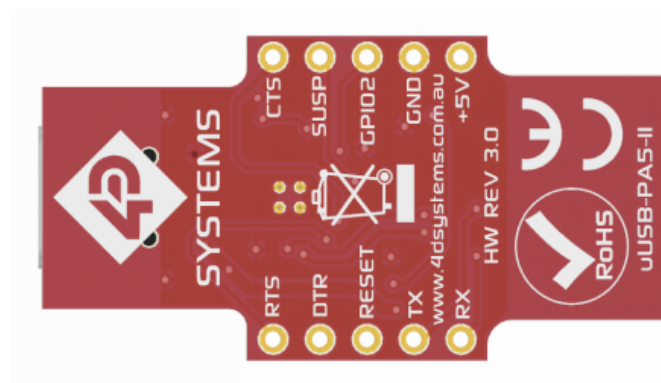
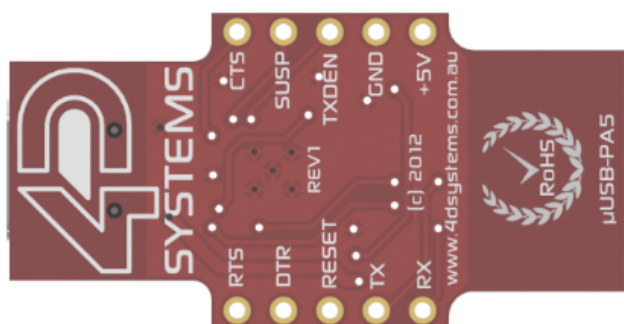

microUSB additional Pin Outs

Symbol	Description
RTS	Ready to Send Output (active low)
DTR	Data Terminal Ready Output (active low)
RESET	This pin provides a LOW-level RESET pulse of several hundred microseconds when the DTR signal is toggled
TX	Serial Data Transmit output. This connects to the host Rx (Serial Receive) input.
RX	Serial Data Receive input. This connects to the host Tx (Serial Transmit) output.
CTS	Clear to Send Input (active low)
SUSP	USB Suspend State (active low)
PA5: TXDEN PA5-II: GPIO2	PA5: Transmit Data Enable, for enabling external circuits such as RS485 (active high) PA5-II: Set to Push/Pull for enabling external circuits such as RS485 (active high)
GND	Ground
+5V	+5V Power from USB (up to 500mA). Power supply to external circuits

5. Typical Applications

The micro USB (**uUSB-PA5/PA5-II****) is designed to accommodate many applications. Its small size and convenient form factor are perfect for adding micro USB functionality to embedded applications.

The primary purpose of the uUSB-PA5 and uUSB-PA5-II is to be the programming interface for 4D Systems products, however, it has a much wider scope and can be utilized for many applications.

The micro USB makes an easy USB-Serial interface, so you can easily create USB to RS-232 converters, USB to RS-422/RS-485 converters, upgrade legacy RS-232 devices, make PDA and cellphone USB interface cables, barcode readers, POS terminals, etc.

In any application, make sure the TX and RX lines from the uUSB are crossed over to the attached peripheral. That is, the TX from the μ USB connects to the RX of the target and the RX from the uUSB connects to the TX of the target device.

Note

The TX and RX signal levels are between 0 Volts and 3.3 Volts, however, are 5.0V tolerant.

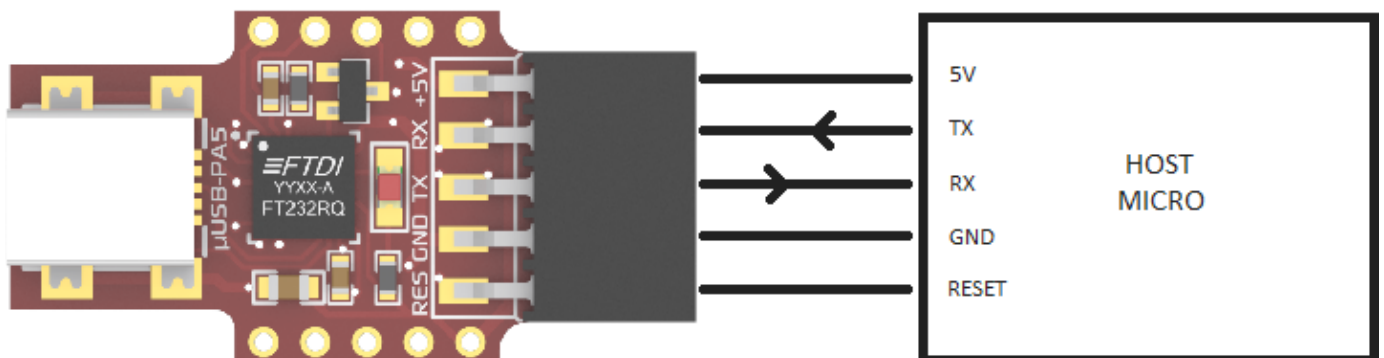

The micro USB is designed to have a compact footprint, and be compatible with prototyping such as plugging it directly into a breadboard when male 2.54mm (0.1") headers are soldered to the row of 5 pins, along each side.

For assistance with the latest driver downloads, please visit the uUSB-PA5 product page of the [4D Systems website](#)

7. Schematic Diagram HW REV 1.0

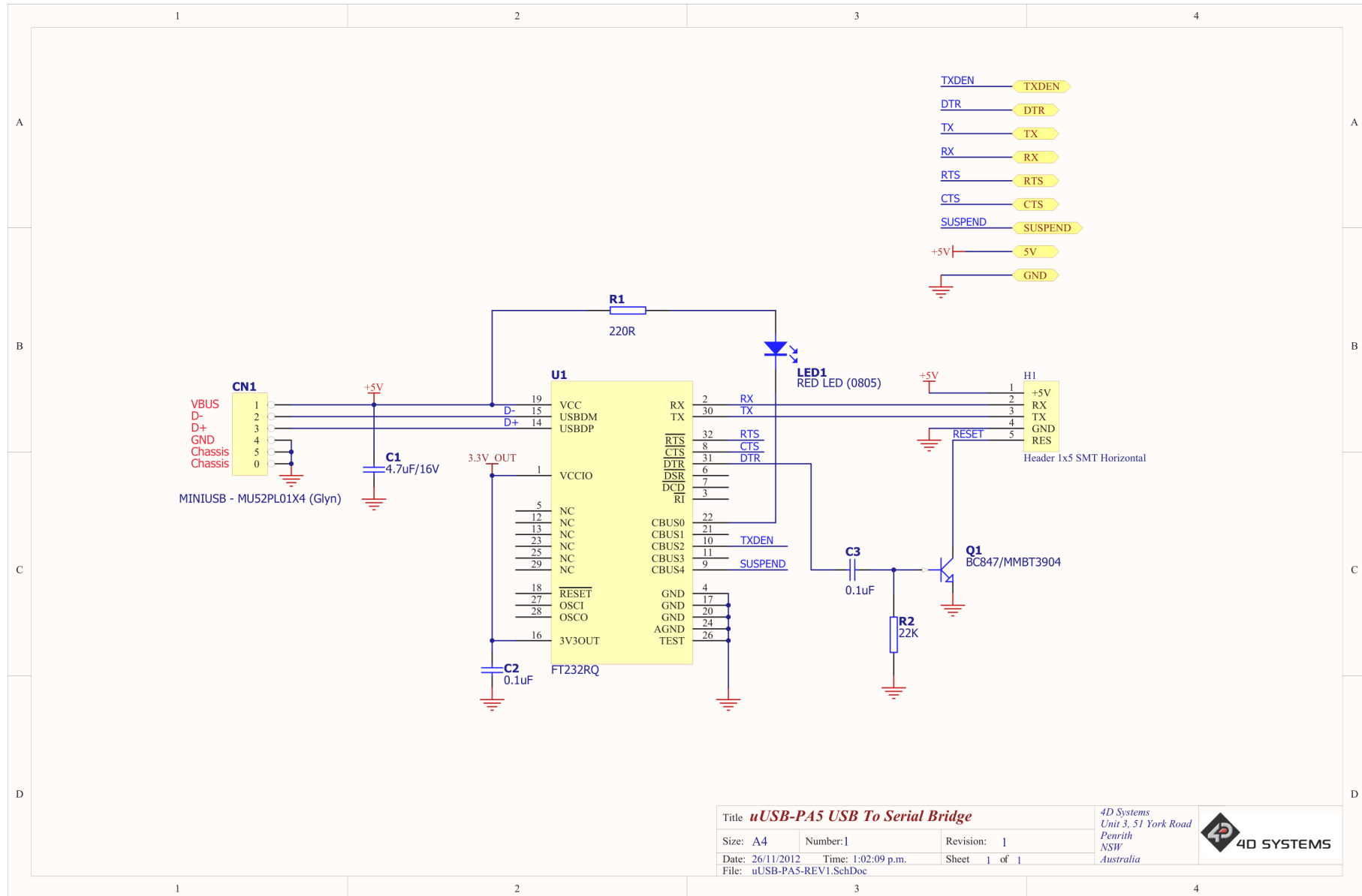

Title uUSB-PA5 USB To Serial Bridge			4D Systems Unit 3, 51 York Road Penrith NSW Australia	
Size: A4	Number: 1	Revision: 1		
Date: 26/11/2012	Time: 1:02:09 p.m.	Sheet 1 of 1		
File: uUSB-PA5-REV1.SchDoc				

8. Schematic Diagram HW REV 3.0

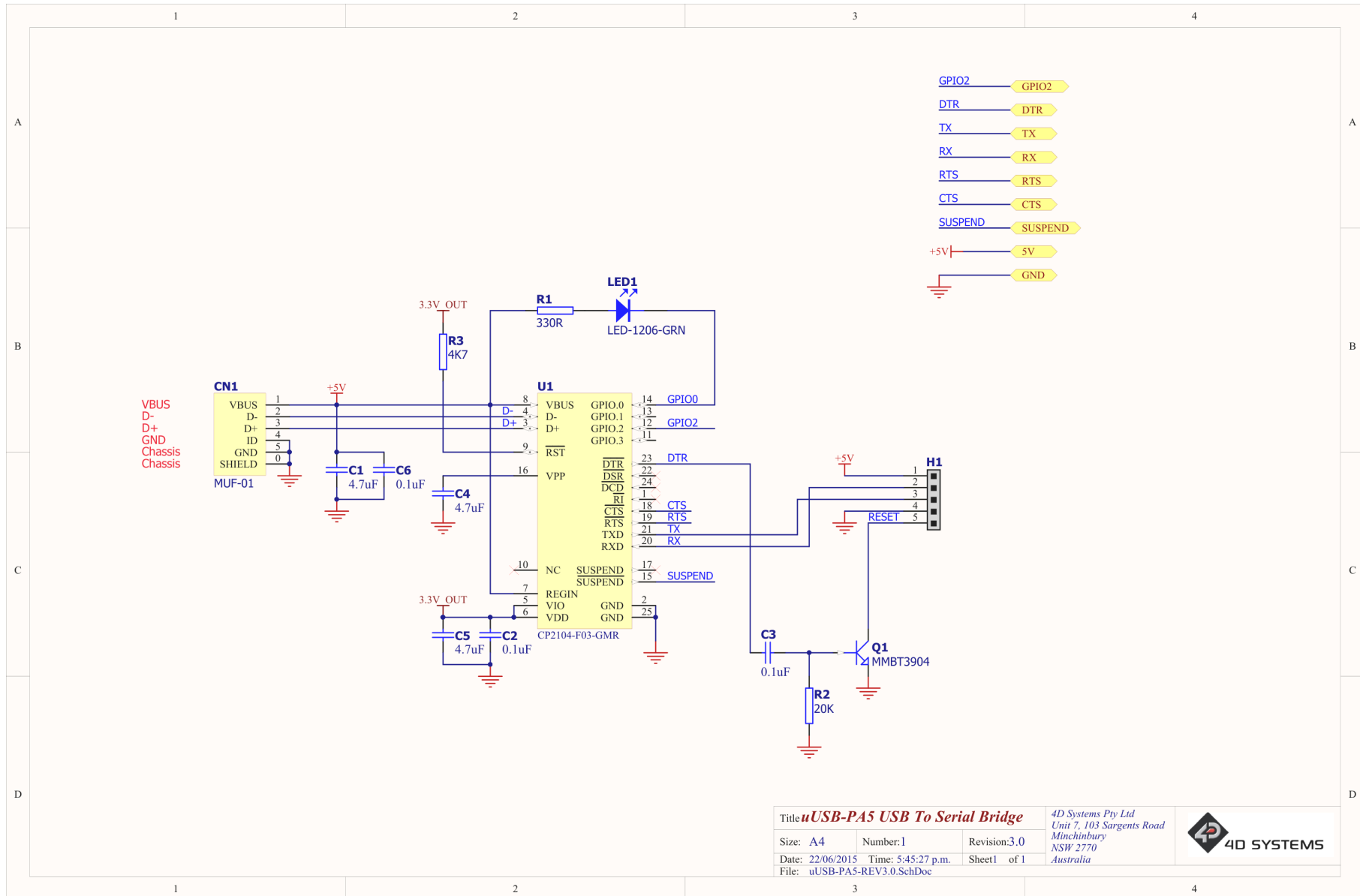

9. Revision History

Hardware Revision

Revision Number	Date	Description
1.0	01/01/2012	Initial Public Release Version
3.0	01/01/2015	Migration to SiLabs CP2104 from FT232RQ

Datasheet Revision

Revision Number	Date	Description
1.0	19/11/2012	Initial Public Release Version
1.1	27/11/2013	Changes on some technical details
2.0	17/07/2015	Introduction of uUSB-PA5-II
2.1	23/03/2019	Cosmetic changes to uUSB-PA5-II Datasheet

10. Ordering Information

ORDERING INFORMATION

Order Code:

uUSB-PA5

uUSB-PA5-II

Package: 90mm x 130mm