

KEYING OPTION "A"
SUGGESTED COLOR: BLACK

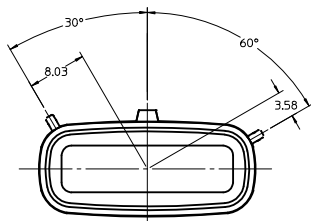

KEYING OPTION "B"
SUGGESTED COLOR: GREY

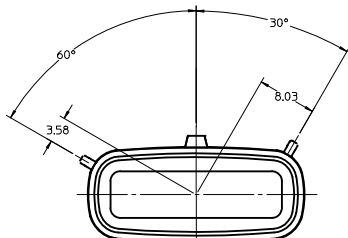

KEYING OPTION "C"
SUGGESTED COLOR: BROWN

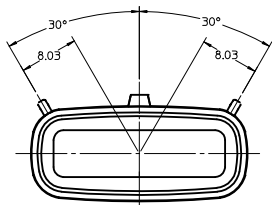

KEYING OPTION "D"
SUGGESTED COLOR: GREEN

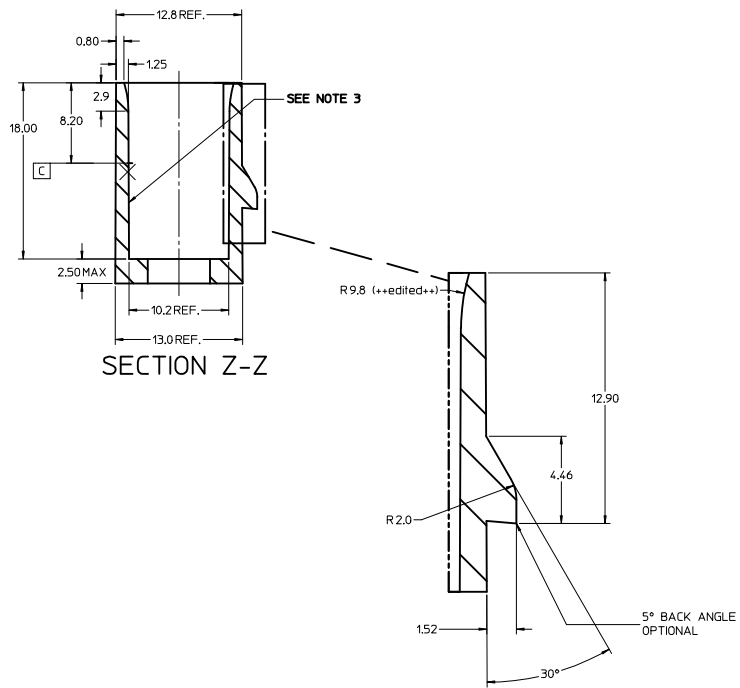
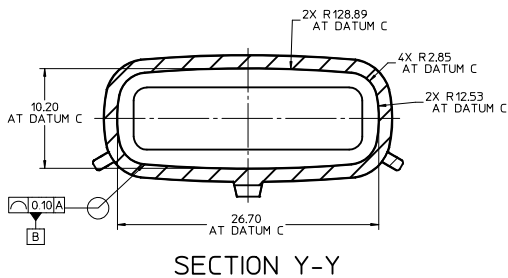
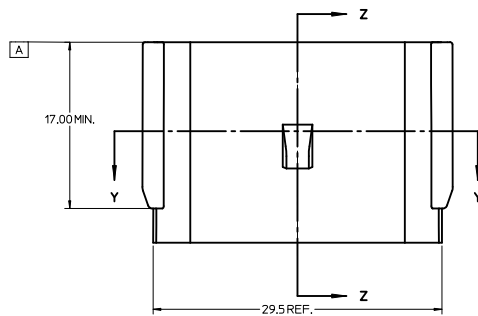
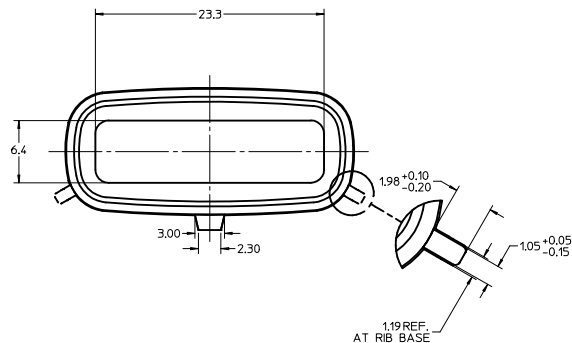

- NOTES:
1. REFER TO MOLEX SALES DRAWING SD-75900-002 FOR THE HEADER ASSEMBLY PRODUCT DETAILS AND RECOMMENDED PCB LAYOUT.
 2. KEYING OPTIONS A-D AND SUGGESTED COLORS COMPLY TO THE POLARIZATION STANDARDS ESTABLISHED FOR MATING WITH A MX150 FEMALE CONNECTOR.
 3. INTERIOR SHROUD SURFACE MUST BE FREE OF DEFECTS AND PARTING LINES ALL AROUND TO ENSURE PROPER SEALING OF THE MATING MX150 FEMALE CONNECTOR.
 4. A FULL SHROUD ON THE MATING CONNECTOR IS REQUIRED TO INSURE THE HEADER SHROUD POLARIZATION FEATURES (OPTIONS A-D) WILL FUNCTION PROPERLY. THE FULL SHROUD ALSO PREVENTS SCOOP DAMAGE TO THE HEADER CONTACTS.
 5. PERMISSIBLE DRAFT ANGLE 0.25° MAXIMUM.
 6. RADI ON ALL CORNERS SHOWN SHARP OR ALL UNSPECIFIED RADII 0.25 EXCEPT AS NOTED.
 7. DIMENSIONS SHOWN ABOUT A CENTERLINE ARE SYMMETRICAL ABOUT THAT CENTERLINE WITHIN HALF THE SPECIFIED TOLERANCE.

NEW RELEASE EC NO. UCP2011-3372 DRAWN BY DROSCA 2010/10/12 CHYD:COMERCI 2011/06/17 APPR:JCOMERCI 2011/06/17	QUALITY SYMBOLS	GENERAL TOLERANCES (UNLESS SPECIFIED)		DIMENSION STYLE		SCALE	DESIGN UNITS	THIRD ANGLE PROJECTION	
	▽=0 ▽=0	mm	INCH	MM ONLY		4:1	METRIC		
		4 PLACES ±---	±---	DRAWN BY	DATE	TITLE	APPLICATION SPEC		
		3 PLACES ±---	±---	DROSCA	2010/10/12	1X6 MX150 R/A HEADER SHROUD DETAILS	MOLEX INCORPORATED		
	2 PLACES ±0.13	±---	CHECKED BY	DATE		DOCUMENT NO.			
	1 PLACE ±0.25	±---	JCOMERCI	2011/06/17		AS-75900-106			
	ANGULAR ±1/2°			APPROVED BY	DATE	SHEET NO.			
		DRAFT WHERE APPLICABLE MUST REMAIN WITHIN DIMENSIONS		JCOMERCI	2011/06/17	1 OF 2			
				MATERIAL NO.		THIS DRAWING CONTAINS INFORMATION THAT IS PROPRIETARY TO MOLEX INCORPORATED AND SHOULD NOT BE USED WITHOUT WRITTEN PERMISSION			
				75900-1060					
				SIZE D					

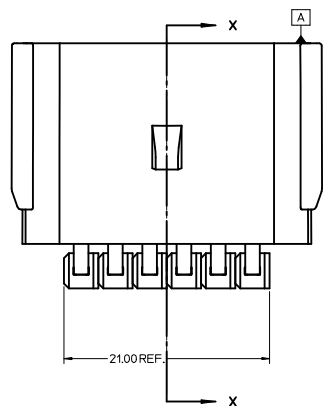
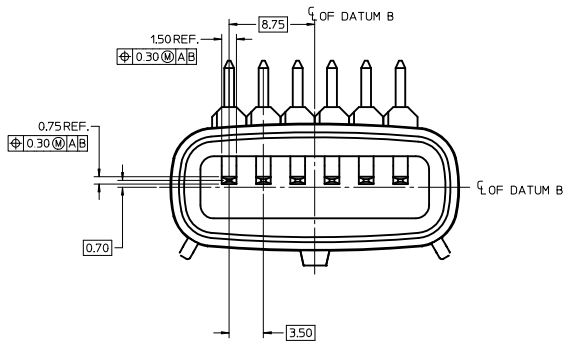

HEADER APPLICATION DETAILS

NOTES:
1. ADHERENCE TO THE HEADER APPLICATION DETAILS IS IMPERATIVE TO ENSURE PROPER SHROUD SEALING AND CONTACT ALIGNMENT WHEN MATED WITH A MX150 FEMALE CONNECTOR.

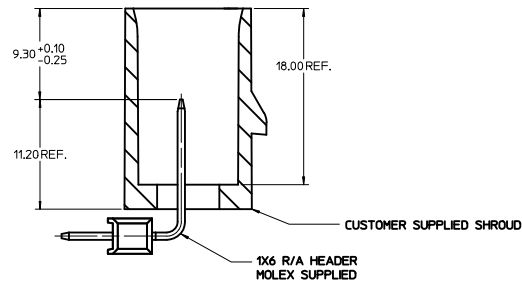

SECTION X-X

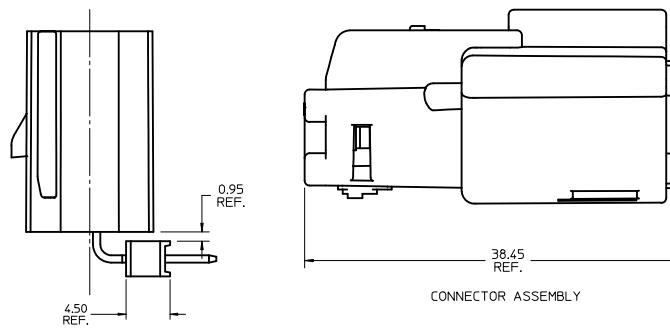

SEE SHT 1 IEC NO: UCP2011-3372 DRAWN: DROSCA 2010/10/12 CHECKED: JCOMERCI 2011/06/17 APPR: JCOMERCI 2011/06/17	QUALITY SYMBOLS	GENERAL TOLERANCES (UNLESS SPECIFIED)	DIMENSION STYLE	SCALE	DESIGN UNITS	THIRD ANGLE PROJECTION	
	▽=0 ▽=0	4 PLACES ± --- ± --- 3 PLACES ± --- ± --- 2 PLACES ± 0.13 ± --- 1 PLACE ± 0.25 ± --- ANGULAR ± 1/2°	MM ONLY	4:1	METRIC	APPLICATION SPEC 1X6 MX150 R/A HEADER SHROUD DETAILS	
	DRAFT WHERE APPLICABLE MUST REMAIN WITHIN DIMENSIONS	DRAWN BY: DROSCA CHECKED BY: JCOMERCI APPROVED BY: JCOMERCI	DATE: 2010/10/12 DATE: 2011/06/17 DATE: 2011/06/17	MATERIAL NO. SEE SHEET 1	DOCUMENT NO. AS-75900-106	SHEET NO. 2 OF 2	MOLEX INCORPORATED
				THIS DRAWING CONTAINS INFORMATION THAT IS PROPRIETARY TO MOLEX INCORPORATED AND SHOULD NOT BE USED WITHOUT WRITTEN PERMISSION			

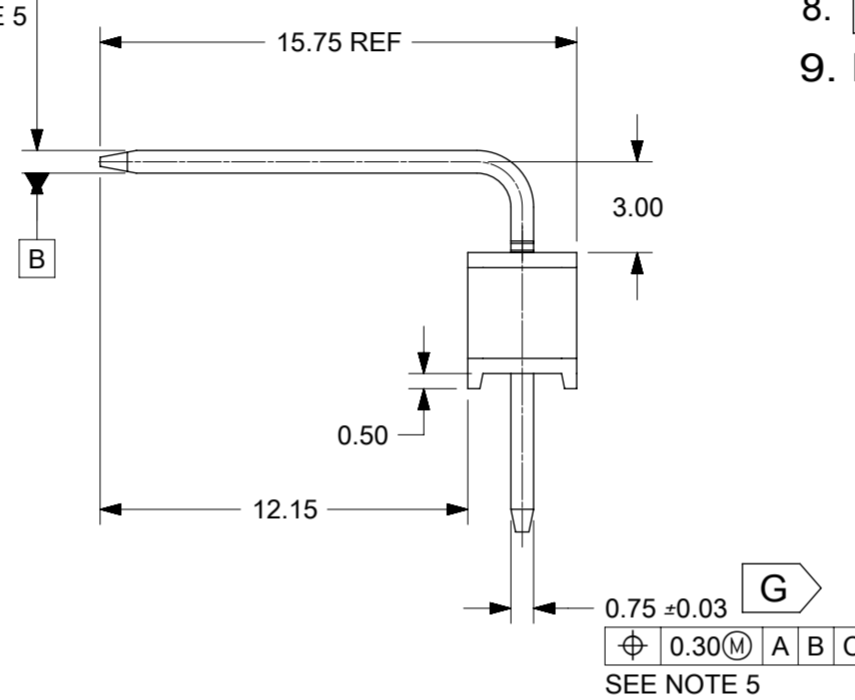
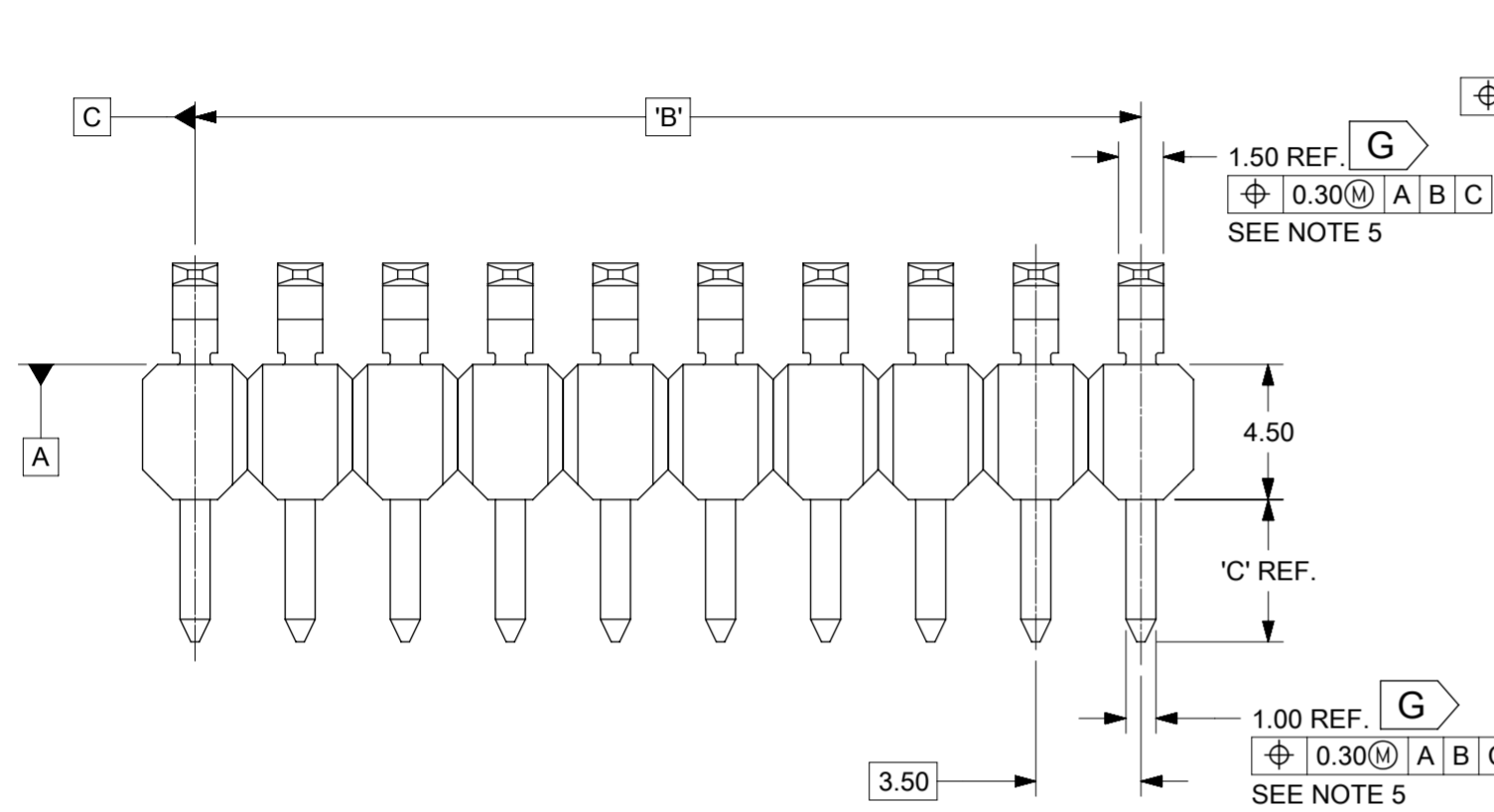
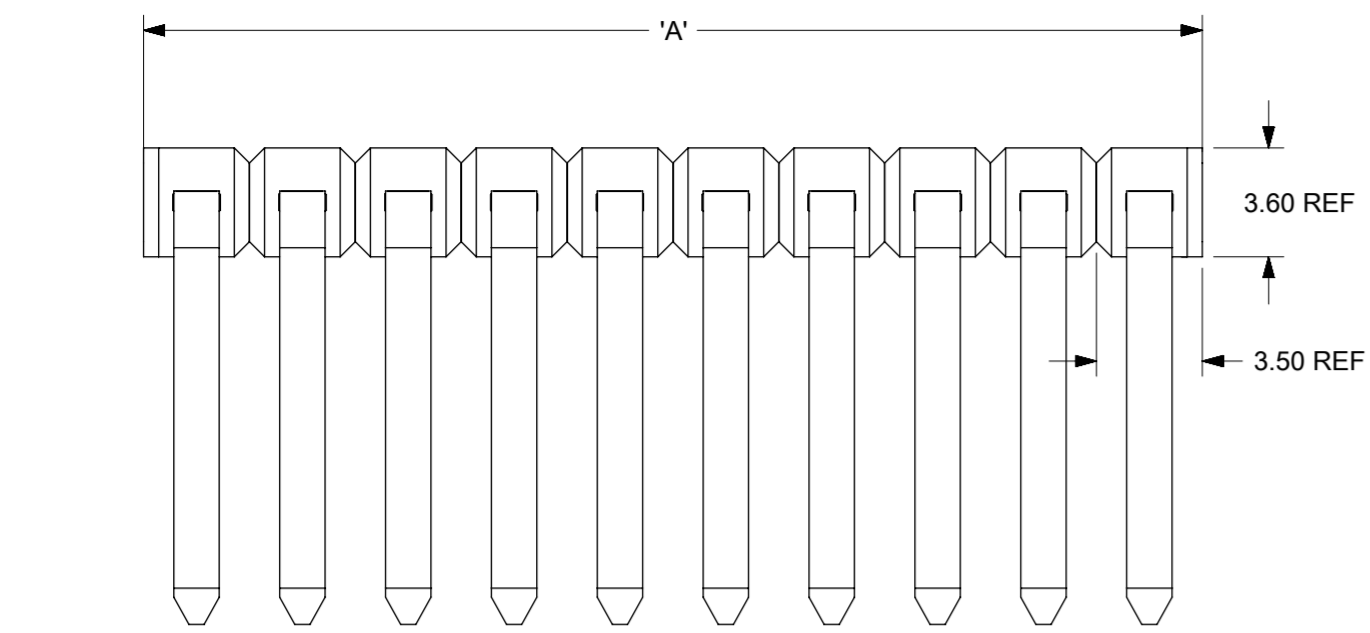

NOTES:

1. TERMINAL MAT'L: ALLOY C26000, CARTRIDGE BRASS
2. WAFER MAT'L: 30% GLASS FILLED LCP, 94V-0, COLOR BLACK.
3. TERMINAL PLATING:
 - OPTION 4 - 1.5 μ m MIN MATTE TIN OVERALL OVER 1.25 μ m NICKEL OVERALL
 - OPTION 1 - 2.5 μ m MIN MATTE TIN OVERALL OVER 1.25 μ m NICKEL OVERALL
 - OPTION 2 - 1.25 μ m NICKEL OVERALL 2.5 μ m MIN SELECT MATTE TIN PC TAIL AREA 0.05-0.25 μ m SELECT GOLD CONTACT AREA
 - OPTION 3 - 1.25 μ m NICKEL OVERALL 2.5 μ m MIN SELECT MATTE TIN PC TAIL AREA 0.75 μ m SELECT GOLD CONTACT AREA
4. HEADER ASSEMBLIES ARE TUBE PACKAGED PER PK-36518-352.
5. ALL THE POSITIONAL TOLERANCES SHOULD BE MEASURED AT TIP OF THE TERMINALS.
6. DATUM SHOULD BE CONSIDERED FROM THE EDGES OF THE HOUSING.
7. POSITION TOLERANCES OF THE PIN AT MATING SIDE SHOULD BE MAINTAINED AT 0.3 MM IN THE FINAL MODULE BY CUSTOMER.
8. **G** DENOTES DIMENSIONS THAT CAN BE QUALIFIED WITH A GAUGE.
9. BLADE GEOMETRY DOES NOT CONFORM TO USCAR SPECIFICATIONS.

CKT SIZE	PLATING OPTION	MATERIAL NUMBER	STATUS	"A" DIM	"B" DIM	"C" DIM	MATERIAL NUMBER	STATUS	"A" DIM	"B" DIM	"C" DIM
1 x 2	1	75900-0121	OBSOLETE	7.0	3.50 REF	3.05	75900-0122	OBSOLETE	7.0	3.50 REF	4.75
	2	75900-0221	OBSOLETE				75900-0222	OBSOLETE			
	3	75900-0321	OBSOLETE				75900-0322	OBSOLETE			
	4	75900-0421					75900-0422	OBSOLETE			
1 x 3	1	75900-0131	OBSOLETE	10.5	7.00	75900-0132	OBSOLETE	10.5	7.00	4.75	
	2	75900-0231	OBSOLETE			75900-0232	OBSOLETE				
	3	75900-0331	OBSOLETE			75900-0332	OBSOLETE				
	4	75900-0431	OBSOLETE			75900-0432	OBSOLETE				
1 x 4	1	75900-0141	OBSOLETE	14.0	10.50	75900-0142	OBSOLETE	14.0	10.50	4.75	
	2	75900-0241	OBSOLETE			75900-0242	OBSOLETE				
	3	75900-0341	OBSOLETE			75900-0342	OBSOLETE				
	4	75900-0441	OBSOLETE			75900-0442	OBSOLETE				
1 x 6	1	75900-0161		21.0	17.50	75900-0162	OBSOLETE	21.0	17.50	4.75	
	2	75900-0261	OBSOLETE			75900-0262	OBSOLETE				
	3	75900-0361	OBSOLETE			75900-0362	OBSOLETE				
	4	75900-0461	OBSOLETE			75900-0462	OBSOLETE				
1 x 8	1	75900-0181	OBSOLETE	28.0	24.50	75900-0182	OBSOLETE	28.0	24.50	4.75	
	2	75900-0281	OBSOLETE			75900-0282	OBSOLETE				
	3	75900-0381	OBSOLETE			75900-0382	OBSOLETE				
	4	75900-0481	OBSOLETE			75900-0482	OBSOLETE				
1 x 10	1	75900-0101	OBSOLETE	35.0	31.50	75900-0102	OBSOLETE	35.0	31.50	4.75	
	2	75900-0201	OBSOLETE			75900-0202	OBSOLETE				
	3	75900-0301	OBSOLETE			75900-0302	OBSOLETE				
	4	75900-0401	OBSOLETE			75900-0402	OBSOLETE				

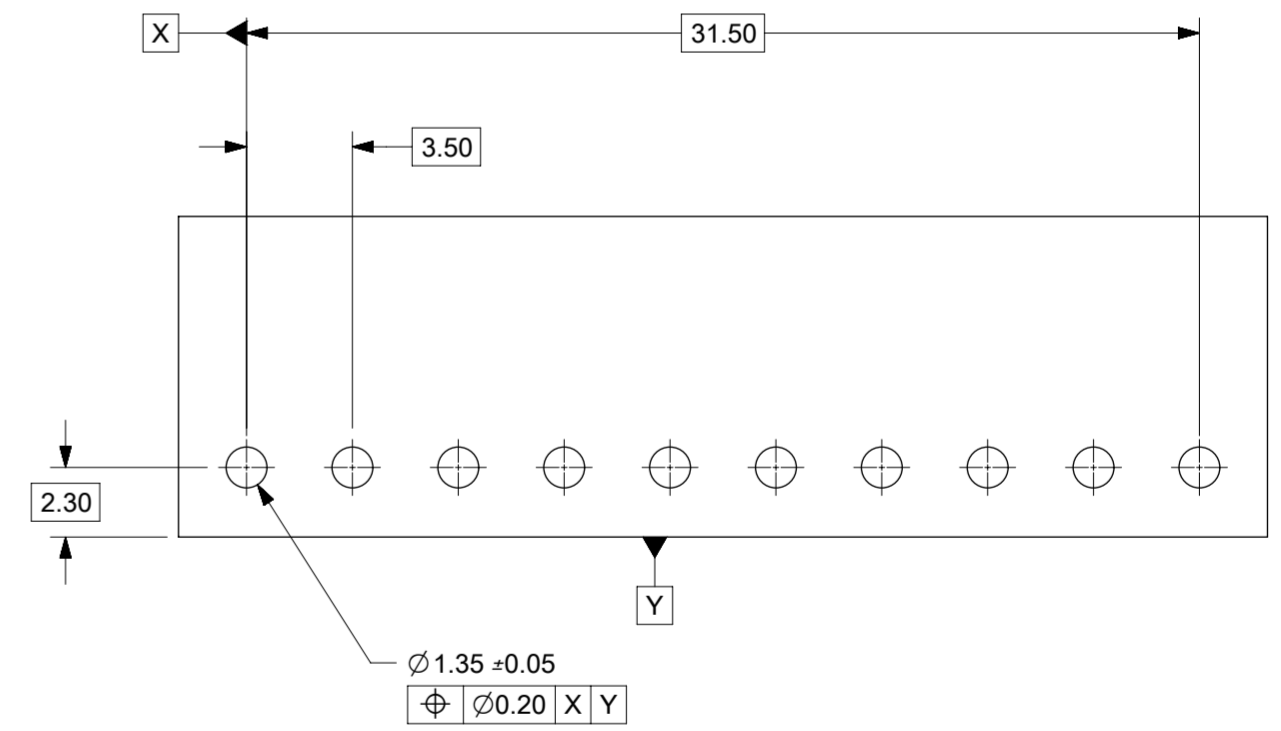

SYMBOLS	THIS DRAWING CONTAINS INFORMATION THAT IS PROPRIETARY TO MOLEX ELECTRONIC TECHNOLOGIES, LLC AND SHOULD NOT BE USED WITHOUT WRITTEN PERMISSION										
	DIMENSION UNITS	SCALE	CURRENT REV DESC: TWO PN's 75900-0261 & 75900-0432 ARE OBSOLETE								
A = 0	mm	1:1	GENERAL TOLERANCES (UNLESS SPECIFIED)								
E = 0	ANGULAR TOL \pm 0.5°		EC NO: 633184							PRODUCT CUSTOMER DRAWING	
F = 0	4 PLACES \pm		DRWN: RYELAVATTITH 2020/02/26							DOCUMENT NUMBER	
S = 0	3 PLACES \pm		CHK'D: RYELAVATTITH 2020/03/02							SD-75900-002	
V = 0	2 PLACES \pm 0.13		APPR: SNAYAK01 2020/03/02							DOC TYPE DOC PART REVISION	
W = 0	1 PLACE \pm 0.25		INITIAL REVISION:							PSD 001 C5	
X = 0	0 PLACES \pm		DRWN: DROSCA 2010/10/12							MATERIAL NUMBER	
Y = 0	DRAFT WHERE APPLICABLE MUST REMAIN WITHIN DIMENSIONS		THIRD ANGLE PROJECTION		DRAWING		SERIES		CUSTOMER		
Z = 0			A2-SIZE		75900		GENERAL MARKET		SHEET NUMBER		
									1 OF 1		