

HAOYU

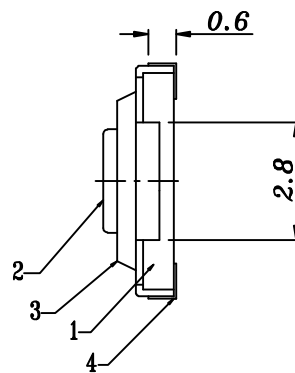

CIRCUIT DIAGRAM

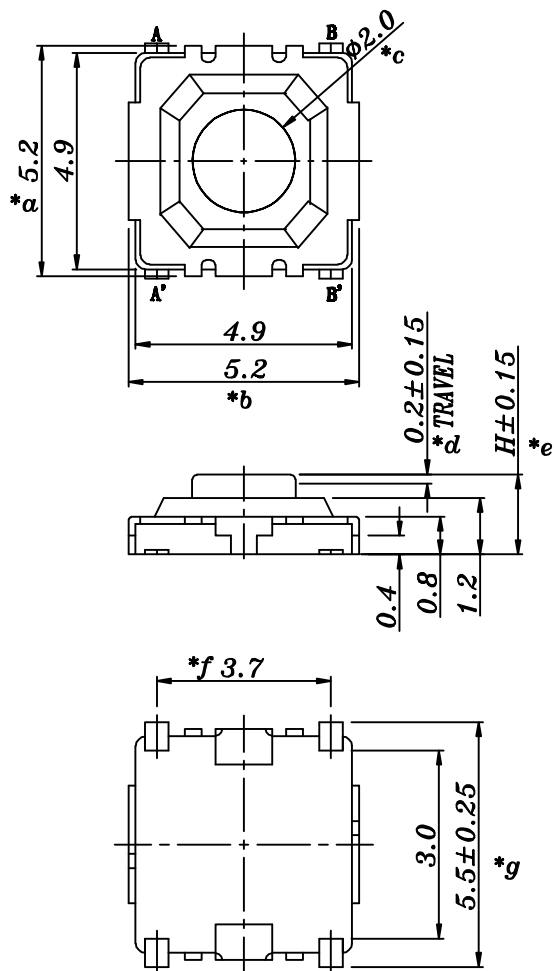
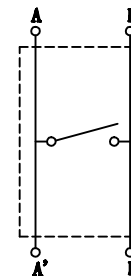

PCB LAYOUT

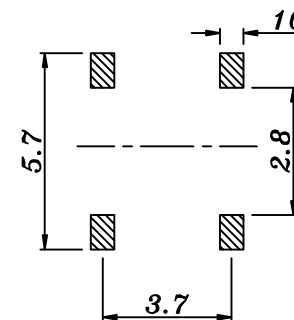

H=XXmm

					TOLERANCE UNLESS SPECIFIED									
					UP TO 5mm: ±0.1	ANGULAR	1	2016.6.6	增加 TRAVEL 尺寸标识					
					ABOVE 5mm: ±0.2	±1°	NO	DATE	REVISIONS		BY	APPD		
4	CONTACT FOOT	BRASS	4	Ag-Plated	TITLE: TACT SWITCH			UNIT : MM	ROHS	DWN				
3	COAT	STAINLESS STEEL	1	Ni-Plated	MODEL: TS-1187U-015C			SCALE: 1:1	COMPLIANT	CHK'D				
2	BUTTON	BRASS	1	Ni-Plated	<b>HAOYU(HONGKONG)LIMITED</b> <b>皓宇(香港)有限公司</b>							APPD		
1	HOUSING	PA6T	1									PRO.AGL:		
NO.	PART NAME	MATERIAL	QTY	FINISHING										