

SCHEMATIC

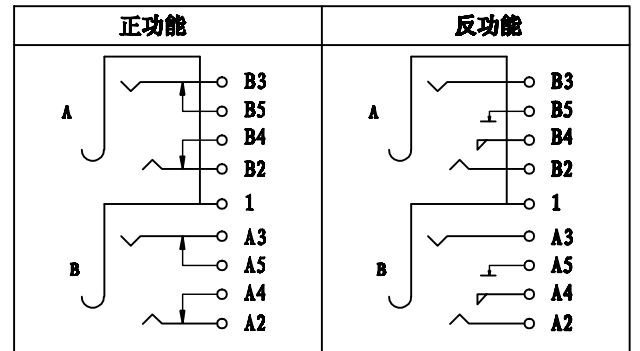

NO.	PART	NAME	MATERIAL	QTY	FINISHING	TOLERANCE UNLESS SPECIFIED		NO		DATE	REVISIONS	BY	APPD
7	1	SPRING	PHOSPHOR BRONZE	1	Sn-Plating	UP TO 5mm: ±0.1	ANGULAR	1	2016.11.23	尺寸由6.2变更为6.5			
6	B5, B4	CURVE PIECE	BRASS	1	Sn-Plating	ABOVE 5mm: ±0.2	±1°	NO					
5	B3, B2	SPRING	PHOSPHOR BRONZE	1	Sn-Plating								
4	A5, A4	CURVE PIECE	BRASS	1	Sn-Plating								
3	A3, A2	SPRING	PHOSPHOR BRONZE	1	Sn-Plating								
2	COAT		BRASS	1	Ni-Plating								
1	HOURSING		PBT	1									
						TITLE: PHONE JACK		UNIT : MM	ROHS COMPLIANT	DWN			
						MODEL: PJ-31030		SCALE: 1:1		CHK'D			
						HAOYU(HONGKONG)LIMITED				APPD			
						皓宇(香港)有限公司				PRO.AGL:		REV :A1	