

■ Features

- Small Package
- Complementary to MMBT3906T

MARKING

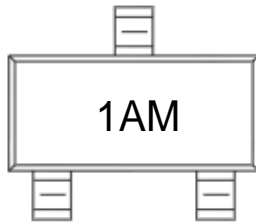

SOT - 23

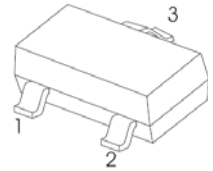

- 1. BASE
- 2. EMITTER
- 3. COLLECTOR

■ Absolute Maximum Ratings Ta = 25°C

Parameter	Symbol	Rating	Unit
Collector - Base Voltage	V <sub>CB0</sub>	60	V
Collector - Emitter Voltage	V <sub>CE0</sub>	40	
Emitter - Base Voltage	V <sub>EB0</sub>	6	
Collector Current - Continuous	I <sub>c</sub>	200	mA
Collector Power Dissipation	P <sub>c</sub>	150	mW
Thermal Resistance, Junction to Ambient	R <sub>θJA</sub>	833	°C/W
Junction Temperature	T <sub>J</sub>	150	°C
Storage Temperature Range	T <sub>stg</sub>	-55 to 150	

■ Electrical Characteristics Ta = 25°C

Parameter	Symbol	Test Conditions	Min	Typ	Max	Unit
Collector- base breakdown voltage	V <sub>CB0</sub>	I <sub>c</sub> = 100 μA, I <sub>E</sub> = 0	60			V
Collector- emitter breakdown voltage	V <sub>CEO</sub>	I <sub>c</sub> = 1 mA, I <sub>B</sub> = 0	40			
Emitter - base breakdown voltage	V <sub>EBO</sub>	I <sub>E</sub> = 100 μA, I <sub>C</sub> = 0	6			
Collector-base cut-off current	I <sub>CBO</sub>	V <sub>CB</sub> = 60 V, I <sub>E</sub> = 0			100	nA
Collector cut-off current	I <sub>CEx</sub>	V <sub>CE</sub> = 30 V, V <sub>EB(off)</sub> =3V			50	
Emitter cut-off current	I <sub>EBO</sub>	V <sub>EB</sub> = 5V, I <sub>C</sub> =0			100	
Collector-emitter saturation voltage	V <sub>CE(sat)</sub>	I <sub>C</sub> =10 mA, I <sub>B</sub> =1mA			0.2	V
		I <sub>C</sub> = 50 mA, I <sub>B</sub> = 5mA			0.3	
Base - emitter saturation voltage	V <sub>BE(sat)</sub>	I <sub>C</sub> =10 mA, I <sub>B</sub> =1mA	0.65		0.85	
		I <sub>C</sub> = 50 mA, I <sub>B</sub> = 5mA			0.95	
DC current gain	h <sub>FE(1)</sub>	V <sub>CE</sub> = 10V, I <sub>C</sub> = 0.1mA	40			
	h <sub>FE(2)</sub>	V <sub>CE</sub> = 10V, I <sub>C</sub> = 1mA	70			
	h <sub>FE(3)</sub>	V <sub>CE</sub> = 10V, I <sub>C</sub> = 10mA	100		300	
	h <sub>FE(4)</sub>	V <sub>CE</sub> = 10V, I <sub>C</sub> = 50mA	60			
Delay time	t <sub>d</sub>	V <sub>CC</sub> =3V, V <sub>BE(off)</sub> =-0.5V			35	nS
Rise time	t <sub>r</sub>	I <sub>C</sub> =10mA, I <sub>B1</sub> =1mA			35	
Storage time	t <sub>s</sub>	V <sub>CC</sub> =3V, I <sub>C</sub> =10mA, I <sub>B1</sub> =I <sub>B2</sub> =1mA			200	
Fall time	t <sub>f</sub>				50	
Collector output capacitance	C <sub>ob</sub>	V <sub>CB</sub> = 5V, I <sub>E</sub> = 0, f=1MHz			4	pF
Base input capacitance	C <sub>ib</sub>	V <sub>EB</sub> =0.5V, I <sub>C</sub> =0, f=1MHz			8	
Transition frequency	f <sub>T</sub>	V <sub>CE</sub> = 20V, I <sub>C</sub> = 10mA, f=100MHz	300			MHz

■ Typical Characteristics

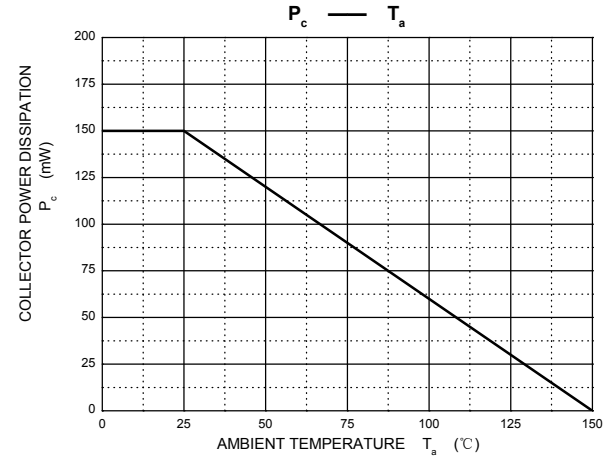
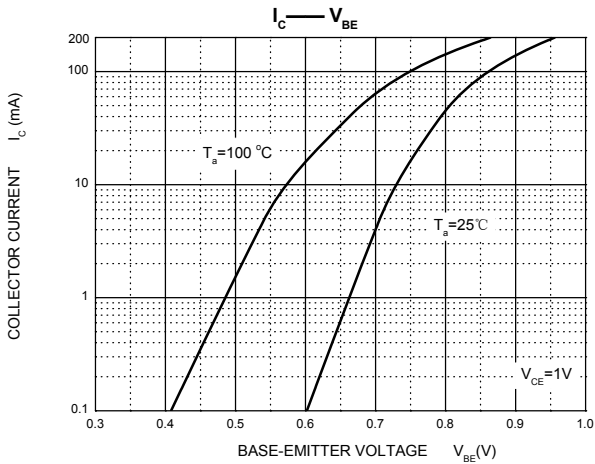
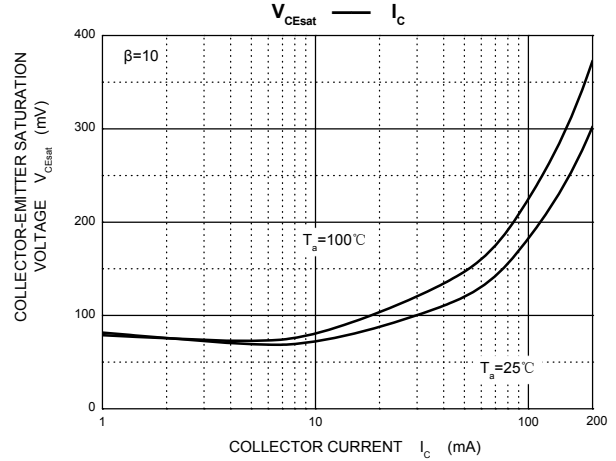
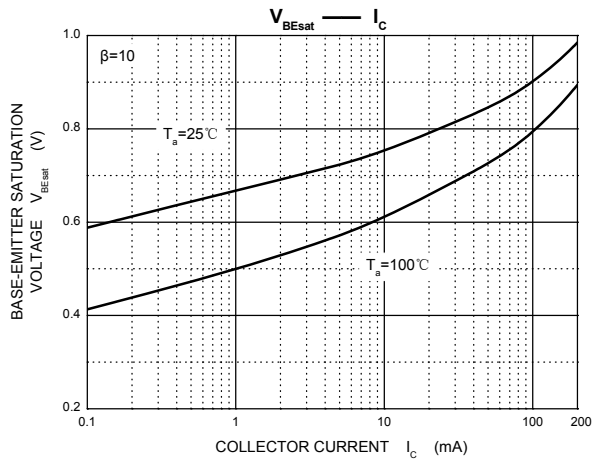
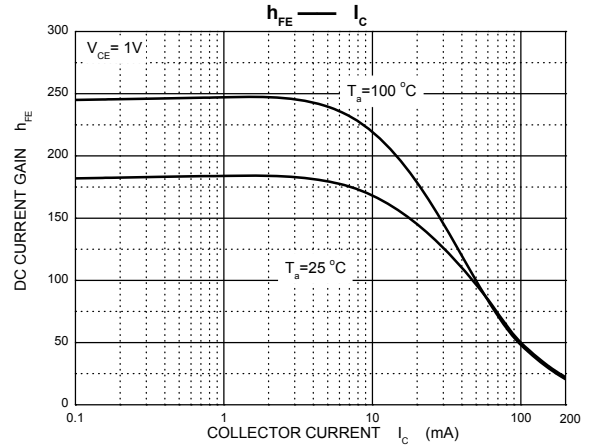
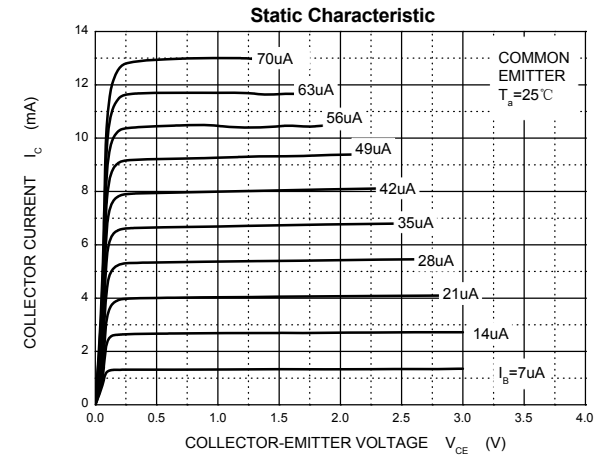

SOT-23 PACKAGE OUTLINE DIMENSIONS

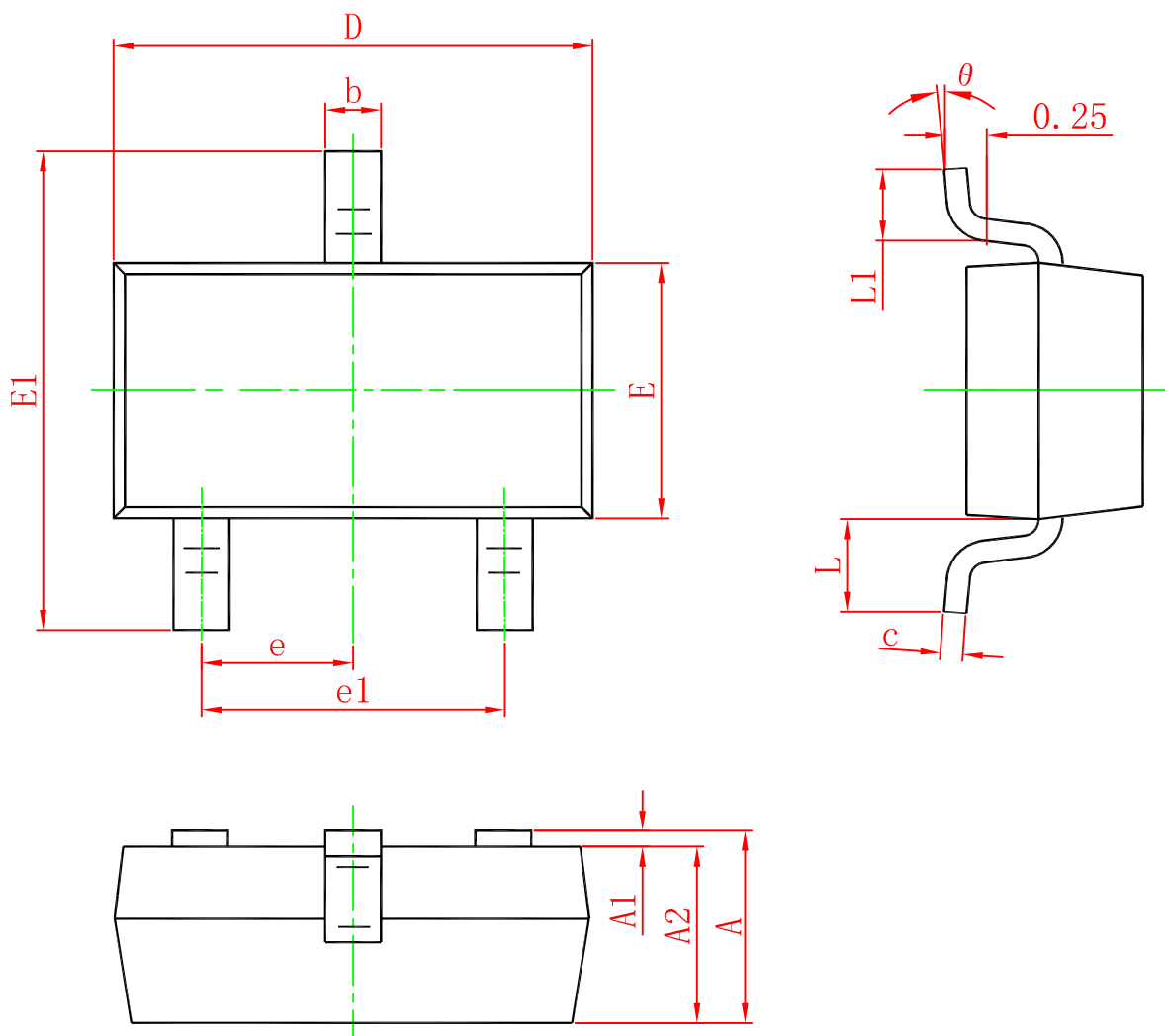

Symbol	Dimensions In Millimeters		Dimensions In Inches	
	Min.	Max.	Min.	Max.
A	0.900	1.150	0.035	0.045
A1	0.000	0.100	0.000	0.004
A2	0.900	1.050	0.035	0.041
b	0.300	0.500	0.012	0.020
c	0.080	0.150	0.003	0.006
D	2.800	3.000	0.110	0.118
E	1.200	1.400	0.047	0.055
E1	2.250	2.550	0.089	0.100
e	0.950 TYP.		0.037 TYP.	
e1	1.800	2.000	0.071	0.079
L	0.550 REF.		0.022 REF.	
L1	0.300	0.500	0.012	0.020
θ	0°	8°	0°	8°