

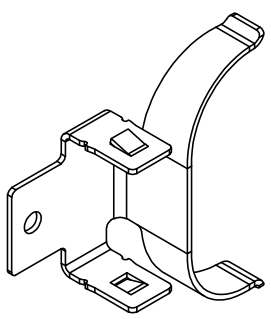

REV.	ECN NO.	REVISED	DATE

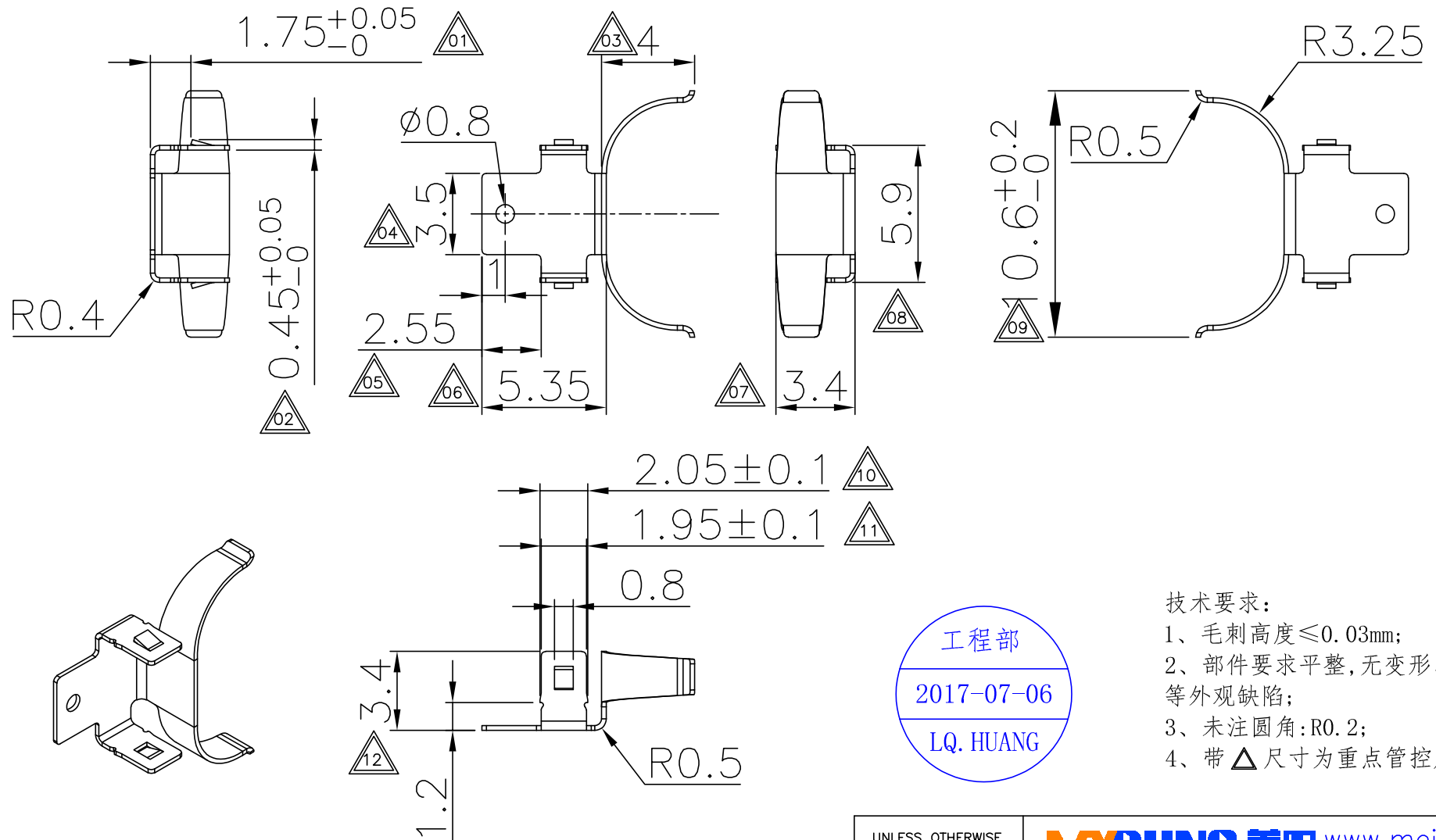

工程部
2017-07-06
LQ. HUANG

- 技术要求:
- 1、毛刺高度≤0.03mm;
 - 2、部件要求平整,无变形、裂纹、损伤等外观缺陷;
 - 3、未注圆角:R0.2;
 - 4、带△尺寸为重点管控尺寸.

UNLESS OTHERWISE SPECIFIED TOLERANCES		MYOUNG 美阳 www.meiyangdz.com	
DECIMALS: X :±0.30 X.X :±0.25 X.XX :±0.20 X.XXX :±0.10	ANGLES: X :±1° X.X :±0.5°	DSND YangFeng	DATE 2017-07-06
		CHKD ZhouRuicai	DATE 2017-07-06
		APVD XueShunyong	DATE 2017-07-06
WEIGHT: 9		SCALE: 1:1	SIZE: A4
SHEET 1 OF 2		VIEW:	TITLE: BS-2032-11 Au 正极端子 卷装
		UNIT: mm	REV.: A/0
		OBJECT: MY	PART NO.: MY-2032-11ZJDZ-R
			DRAW NO.:MY-CP-0378

1	TERMINAL(+)	1	PHOSPHOR BRONZE, T=0.20mm	Au-Plating
NO.	PART NAME	Q'TY	MATERIAL	PLATING & COLOR

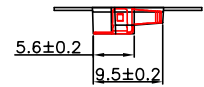
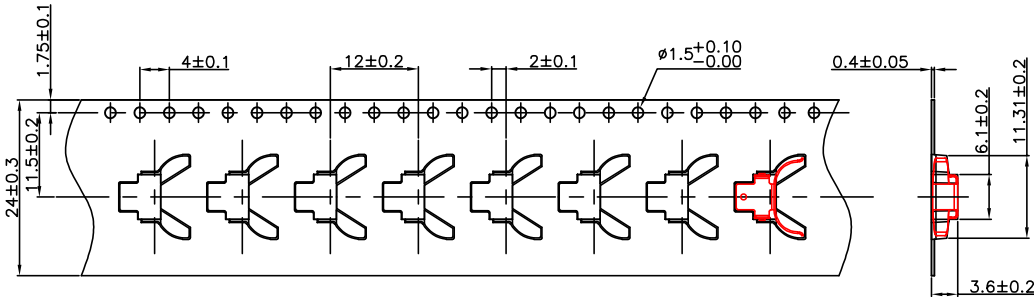
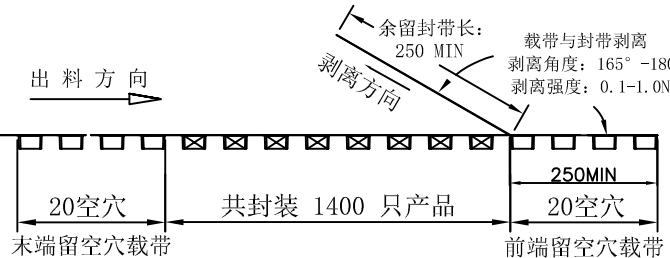
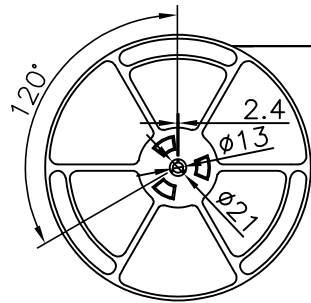
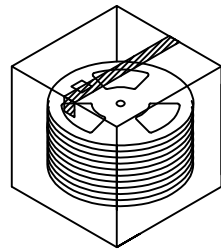
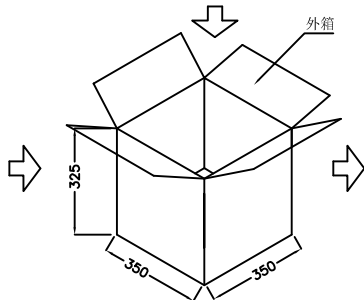
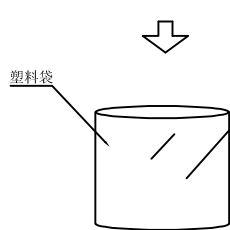
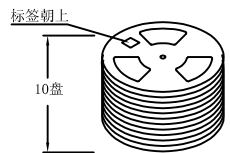
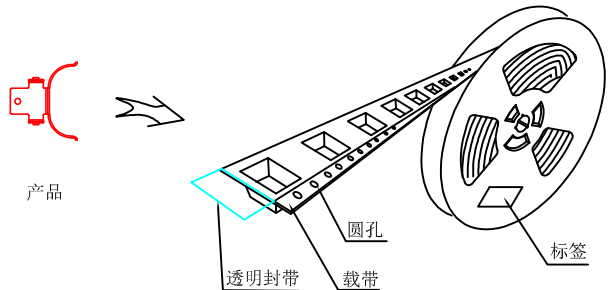
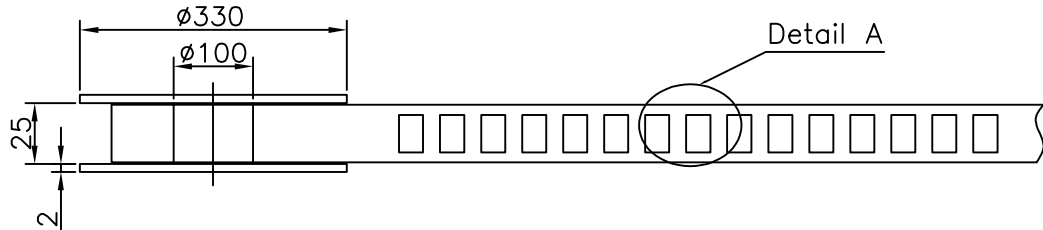

工程部
2023-09-20
H. WANG

技术要求:
1. 圆孔十个孔距离累计允许公差为 $\pm 0.2\text{mm}$
2. 带长250mm内容许弯曲度1mm
3. 材料厚度以在载带边缘测量为准
4. 所有尺寸定义依循EIA-481-C系准则定义之
5. 材料:PS雾透 T=0.4 \pm 0.05mm
6. 所有卷轮为灰蓝挖空旋转塑胶卷轮
7. 整模成型长度:17.28M,
8. 非指明公差范围为: $\pm 0.1\text{mm}$;超过250mm不计算累计误差
9. 型腔外形凡未标明处倒角R为0.2-0.3; 拔模斜度未标注的为3° 以下

包装信息:
1、每卷盘装产品 1400 只, 卷盘外侧贴相关标签;
2、每 10 卷盘放在一个塑料袋中;
3、每外箱装10盘, 产品总数: 14000 只;
4、外箱上下用胶纸封成“工”字;
4、电池弹片包材BS-2032-11 Au 正极端子 卷装 (BS-2032-11ZJDZ-R)

UNLESS OTHERWISE SPECIFIED TOLERANCES		MYOUNG 美阳 www.meiyangdz.com	
DECIMALS: X : ±*** X.X : ±*** X.XX : ±*** X.XXX : ±***	ANGLES: X : ±*** X.X : ±***	DSND YangFeng	DATE 2023-09-20
		CHKD ZhouRuicai	DATE 2023-09-20
		APVD XueShun Yong	DATE 2023-09-20
		TITLE: BS-2032-11 Au 正极端子 卷装	
WEIGHT:		PART NO.: BS-2032-11ZJDZ-R	
SHEET 2 OF 2		SCALE: 1:1	VIEW:
		UNIT: mm	REV.: A/0
		OBJECT: MY	DRAW NO.: MY-BD-0079