

DESCRIPTION: MALE - WIRE WRAP / MACHINED - PREMIUM

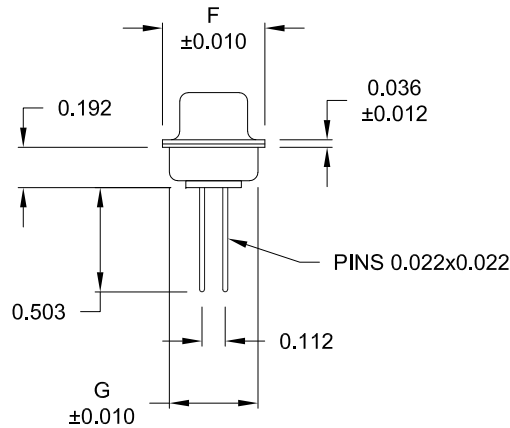
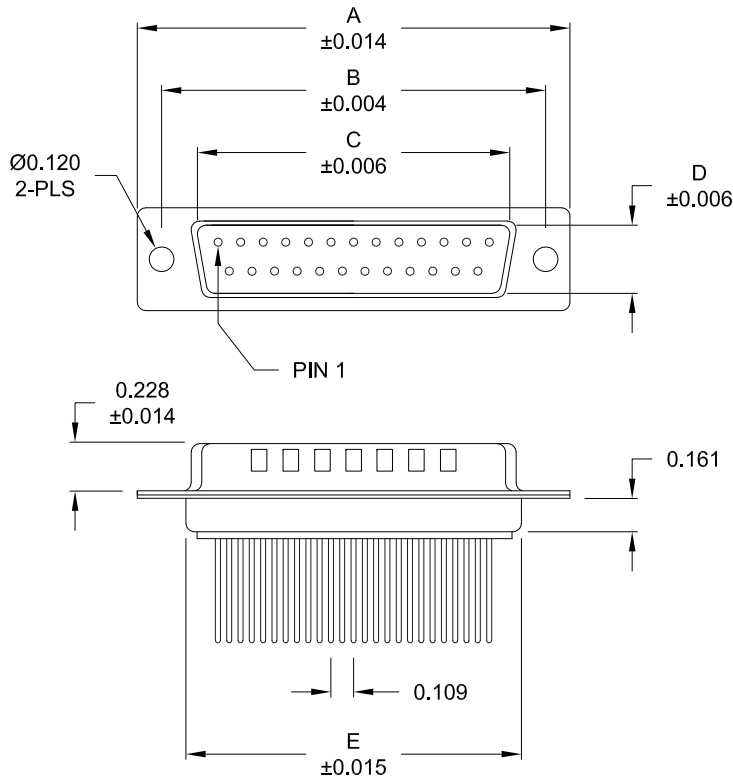

No. OF PINS	DIMENSIONS						
	A	B	C	D	E	F	G
9	1.213	0.984	0.669	0.331	0.760	0.496	0.429
	30.80	24.99	17.00	8.40	19.30	12.60	10.90
15	1.541	1.312	0.996	0.331	1.083	0.496	0.429
	39.15	33.32	25.30	8.40	27.51	12.60	10.90
25	2.088	1.852	1.535	0.331	1.630	0.496	0.429
	53.04	47.04	39.00	8.40	41.40	12.60	10.90
37	2.729	2.500	2.181	0.331	2.276	0.496	0.429
	69.32	63.50	55.40	8.40	57.81	12.60	10.90
50	2.635	2.406	2.079	0.437	2.182	0.598	0.535
	66.93	61.11	52.80	11.10	55.42	15.20	13.60

172-YYY-142RYY1

SERIES _____
 POSITIONS _____
 009
 015
 025
 037
 050
 GENDER _____
 1 = MALE
 TERMINATION _____
 4 = WIRE WRAP
 SHELL PLATING _____
 2 = TIN (GROUND INDENTS)
 RoHS COMPLIANT _____
 HARDWARE OPTIONS _____
 00 = NO HARDWARE
 01 = .065" CLINCH NUT (BOARD SIDE)
 02 = .250" CLINCH NUT (BOARD SIDE)
 03 = .250" CLINCH NUT (MOUNTING SIDE)
 05 = .237" 4-40 BOARD LOCK
 91 = .237" 4-40 SPACER/ BOARD LOCK
 PLATING OPTIONS _____
 1 = GOLD FLASH
 2 = 30MICRO-INCH GOLD

MATERIAL:

SHELL: STEEL, TIN PLATED
 INSULATOR: UL 94V-O RATED, PA6T
 PROCESS TEMP.: 260°C
 CONTACT: BRASS

ELECTRICAL:

CURRENT RATING: 5 AMPS
 CONTACT RESISTANCE: 15 mOhms Max.
 INSULATION RESISTANCE: 1,000 MOhms Min.
 VOLTAGE: 500VAC FOR 1 MINUTE
 TEMPERATURE: -50° C TO 100° C

DO NOT SCALE FROM DRAWING



THESE DRAWINGS AND SPECIFICATIONS ARE THE PROPERTY OF NorComp AND SHALL NOT BE REPRODUCED, COPIED OR USED AS THE BASIS FOR THE MANUFACTURE OF SALE OF APPARATUS WITHOUT WRITTEN PERMISSION.

DRAWN: PAM JENKINS
 DATE: 11-23-05

NorComp

SCALE: NTS SHEET 1 OF 3 REV 13
 DWG NO. 172-YYY-142RYY1

RoHS COMPLIANT

DESCRIPTION: PCB LAYOUT - STANDARD "D" - MALE & FEMALE

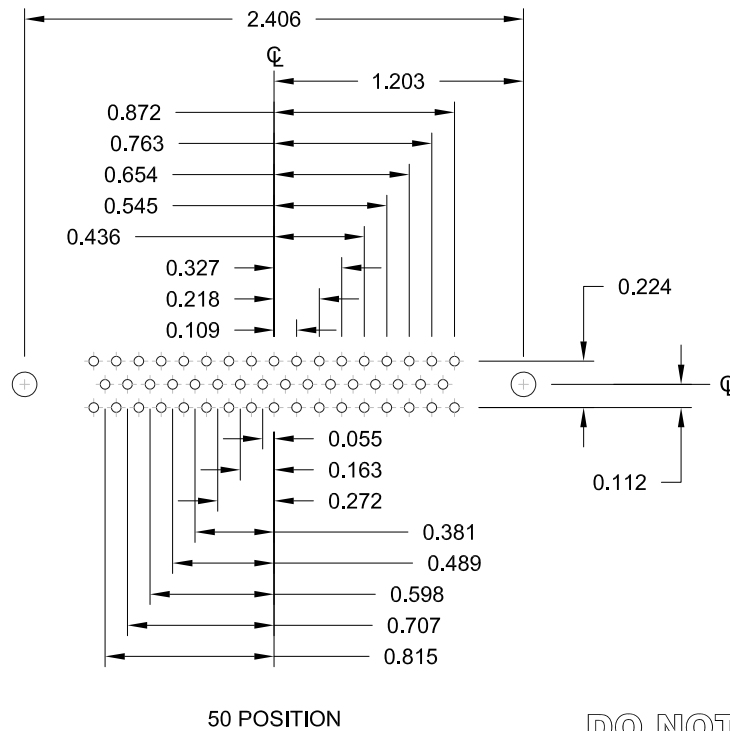
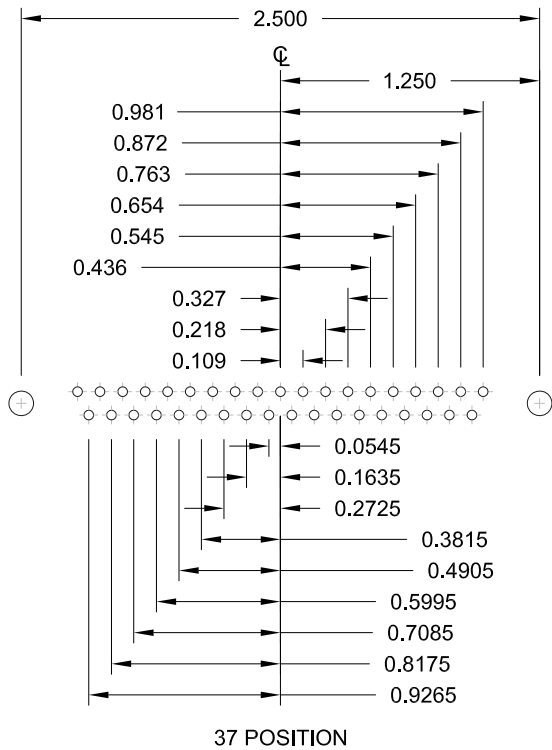
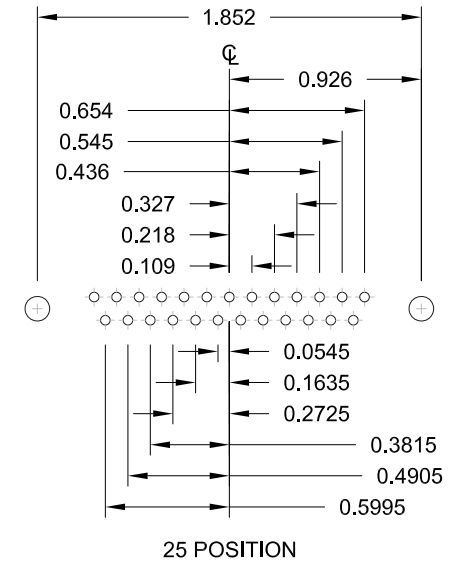
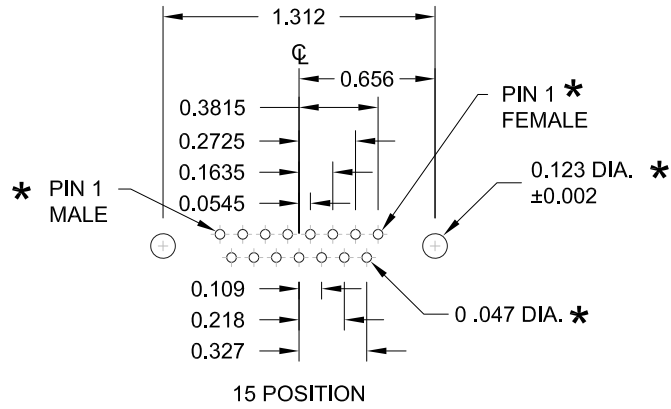
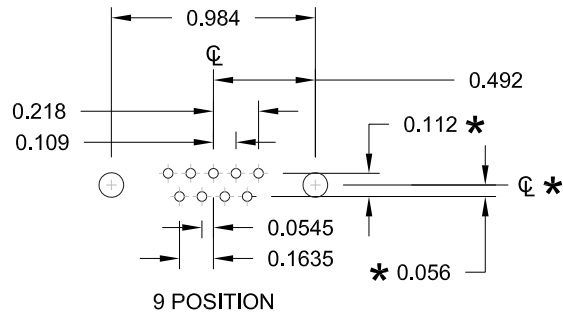

* TYP. ON ALL SIZES

DO NOT SCALE FROM DRAWING

	THESE DRAWINGS AND SPECIFICATIONS ARE THE PROPERTY OF NorComp AND SHALL NOT BE REPRODUCED, COPIED OR USED AS THE BASIS FOR THE MANUFACTURE OF SALE OF APPARATUS WITHOUT WRITTEN PERMISSION.		DRAWN: PAM JENKINS	DATE: 11-23-05
	NorComp		SCALE: NTS	SHEET OF 2 3
DWG NO. 172-YYY-142RYY1				

ALL CLINCH-NUTS ARE 4-40 INTERNAL THREADS

01X 0.065" (BOARD SIDE)

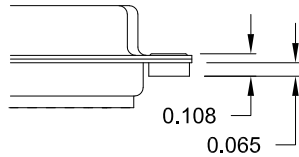

02X 0.250" (BOARD SIDE)

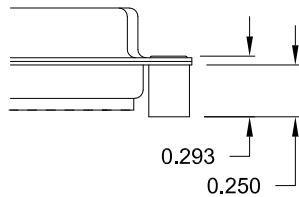

03X..... 0.250" (MATING SIDE)

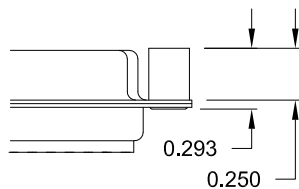

05X 0.237" (BOARD SIDE)

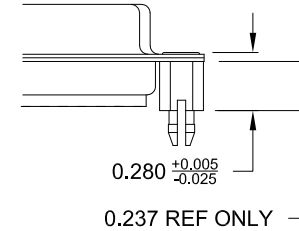

91X 0.237" (BOARD SIDE)

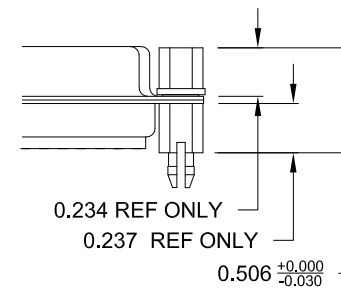

TOLERANCE:
ALL DIMENSIONS ARE ± 0.010
UNLESS OTHERWISE
SPECIFIED

NOTE: 4-40 FEMALE SCREW LOCK IS REMOVABLE

DO NOT SCALE FROM DRAWING

RoHS COMPLIANT

	THESE DRAWINGS AND SPECIFICATIONS ARE THE PROPERTY OF NorComp AND SHALL NOT BE REPRODUCED, COPIED OR USED AS THE BASIS FOR THE MANUFACTURE OF SALE OF APPARATUS WITHOUT WRITTEN PERMISSION.		DRAWN: PAM JENKINS	DATE: 11-23-05
	NorComp		SCALE: NTS	SHEET OF 3 3
DWG NO. 172-YYY-142RYY1				