

## **HAL120X CMOS Unipolar High Sensitivity Micropower Hall Switch**

### **1. General Description**

The HAL120X is fabricated from mixed signal CMOS technology. It internally includes an on-chip Hall voltage generator, a voltage regulator for operation with supply voltages of 1.65 to 5.5V, a sleep/awake logic for low power consumption, temperature compensation circuitry, small-signal amplifier, Hall sensor with dynamic offset cancellation system, Schmitt trigger and an open-drain output. A south pole of sufficient strength will turn the sensor output on. The output will be turned off under no magnetic field. While the magnetic flux density (B) is larger than operating point (Bop), the output will be turned on (low), the output is held until B is lower than release point (Brp), and then turned off.

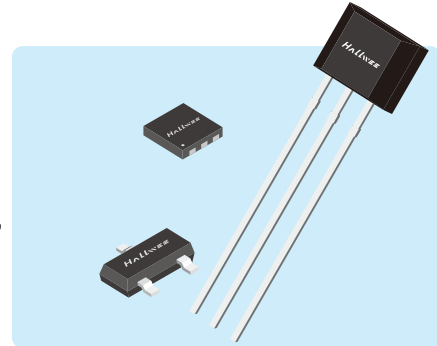

The total power consumption in normal operation is typically 15 $\mu$ W with a 3.3V power source. Operating temperature range of the HAL120X is from -40°C to 85°C.

### **2. Features and Benefits**

CMOS Hall IC Technology

Strong RF noise protection

1.65 to 5.5V for battery-powered applications

Micropower consumption

Multi Small Size option

Low sensitivity drift in crossing of Temp. range Ultra Low power consumption at 5 $\mu$ A (Avg)

High ESD Protection, HBM> +/- 4KV( min ) Totem-pole output

Package: TO-92S, SOT23-3, SOT553, DFN1216-4L

### 3.Applications

Solid state switch

Handheld Wireless Handset Awake Switch ( Flip Cell/PHS Phone/Note Book/Flip Video Set)

Magnet proximity sensor for reed switch replacement in low duty cycle applications

TWS

Notebook / PAD PC / PDA

### 4. Typical Application Circuit

Our pole-independent sensing technique allows for operation with either a north pole or south pole magnet orientation, enhancing the manufacturability of the device. The state-of-the-art technology provides the same output polarity for either pole face.

It is strongly recommended that an external bypass capacitor be connected (in close proximity to the Hall sensor) between the supply and ground of the device to reduce both external noise and noise generated by the chopper-stabilization technique. This is especially true due to the relatively high impedance of battery supplies.

### 5. Functional Block Diagram

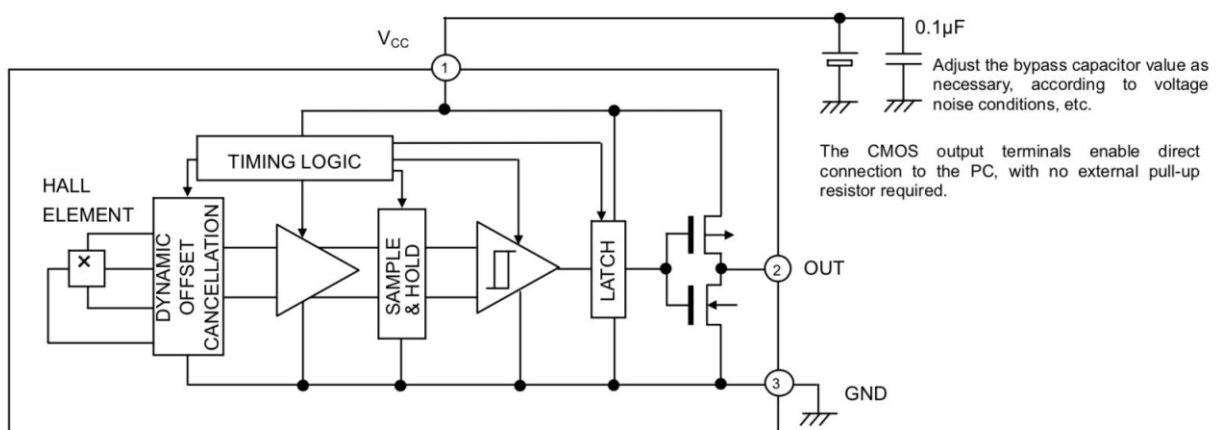

## 6. Pinning

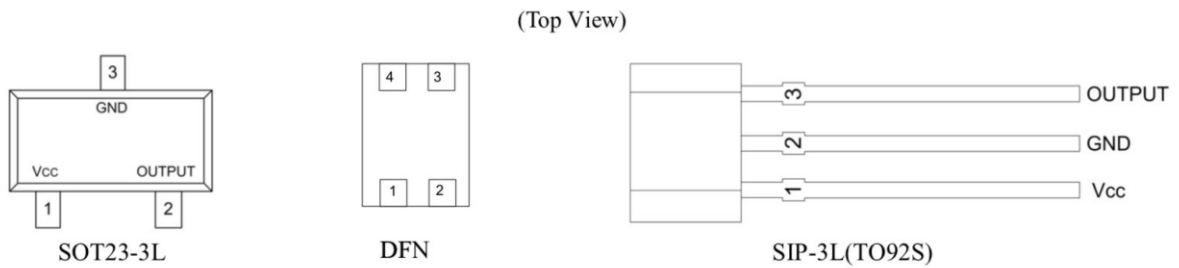

SOT Pin Number	SIP Pin Number	Pin Name	Function
1	1	VCC	Supply Voltage
2	3	OUT	CMOS Output
3	2	GND	Ground
4	NC		

### SOT553

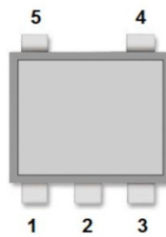

SOT Pin Number	SIP Pin Number	Pin Name	Function
1	1	VCC	Supply Voltage
2	3	OUT	CMOS Output
3	2	GND	Ground
4	NC		

## 7. DESCRIPTION of OPERATIONS

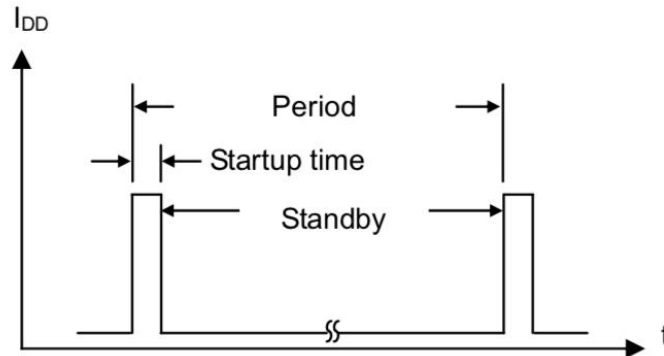

The unipolar detection Hall IC adopts an intermittent operation method to save energy. At startup, the Hall elements, amp, comparator and other detection circuit power ON and magnetic detection begins. During standby, the detection circuits power OFF, thereby reducing current consumption. The detection results are held while standby is active, and then output.

Reference period: 50ms (MAX100ms) Reference startup time: 24 $\mu$ s

### INTERMITTENT OPERATION at POWER ON

The unipolar detection Hall IC adopts an intermittent operation method in detecting the magnetic field during startup, as shown in Fig.5. It outputs to the appropriate terminal based on the detection result and maintains the output condition during the standby period. The time from power ON until the end of the initial startup period is an indefinite interval, but it cannot exceed the maximum period, 100ms. To accommodate the system design, the Hall IC output read should be programmed within 100ms of power ON, but after the time allowed for the period ambient temperature and supply voltage.

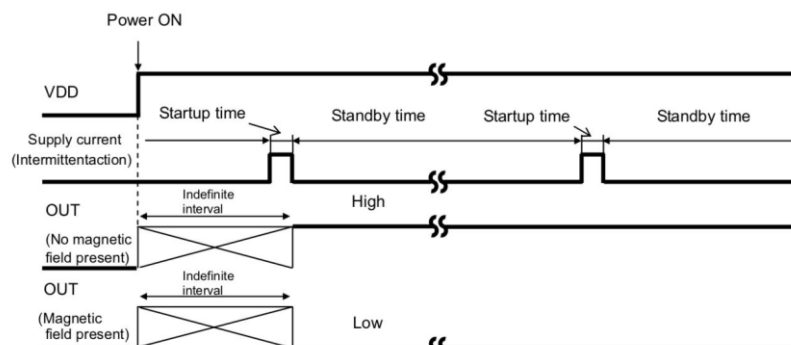

## 8. Typical Application Circuit

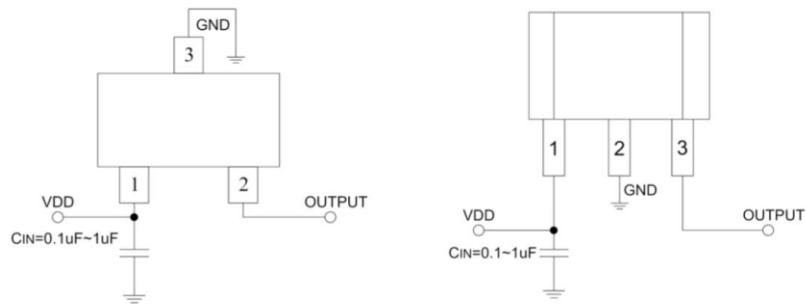

Note:  $C_{IN}$  is for power stabilization and to strengthen the noise immunity, the recommended capacitance is 0.1~1 $\mu$ F.

## 9. Absolute Maximum Ratings

Parameter	Symbol	Value	Units
Supply Voltage(operating)	$V_{DD}$	6	V
Supply Current	$I_{DD}$	1	mA
Output Voltage	$V_{OUT}$	6	V
Output Curent	$I_{OUT}$	1	mA
Operating Temperature Range	$T_A$	-40 to 85	$^{\circ}$ C
Storage Temperature Rang	$T_S$	-50 to 150	$^{\circ}$ C
ESD Sensitivity	-	4000	V

Exceeding the absolute maximum ratings may cause permanent damage. Exposure to absolute-maximum rated conditions for extended periods may affect device reliability.

## 10. DC Electrical Characteristics

 DC Operating Parameters:  $T_A = 25^\circ\text{C}$ ,  $V_{DD}=2.75\text{V}$ .

Parameter	Symbol	Test Conditions	Min	Typ	Max	Units
Operating voltage	$V_{DD}$	Operating	1.8	3.3	5.5	V
Output High Voltage	$V_{OH}$	$B < BrpS \quad I_{OUT} = -0.5\text{mA}$	$V_{DD}-0.2$	-	-	
Output Low Voltage	$V_{OL}$	$BopS < B \quad I_{OUT} = +0.5\text{mA}$	-	-	0.2	
Supply current1	$I_{DD1(AVG)}$	$V_{DD}=1.8\text{V}$ , Average	-	1.1	-	$\mu\text{A}$
Supply Current During Startup Time 1	$I_{DD1(EN)}$	$V_{DD}=1.8\text{V}$ , During Startup Time Value	-	0.7	-	mA
Supply Current During Standby Time 1	$I_{DD1(DIS)}$	$V_{DD}=1.8\text{V}$ , During Standby Time Value	-	0.42	-	$\mu\text{A}$
Supply current1	$I_{DD1(AVG)}$	$V_{DD}=3.0\text{V}$ , Average	-	2.4	-	$\mu\text{A}$
Supply Current During Startup Time 1	$I_{DD1(EN)}$	$V_{DD}=3.0\text{V}$ , During Startup Time Value	-	1	-	mA
Supply Current During Standby Time 1	$I_{DD1(DIS)}$	$V_{DD}=3.0\text{V}$ , During Standby Time Value	-	1.4	-	$\mu\text{A}$
Awake mode time	$T_{AW}$	Operating	-	25	-	$\mu\text{S}$
Sleep mode time	$T_{SL}$	Operating	-	50	100	mS

## 11. Magnetic Characteristics

Operating Parameters:  $T_A = 25^\circ\text{C}$ ,  $V_{DD}=2.75V_{DC}$ .

PARAMETER	Symbol	Min	Type	Max	Units
Operating Point	Bop	-	35	50	Gs
Release Point	Brp	6	22	-	Gs
Hysteresis	Bhys	-	13	-	Gs

## 12. Field Direction Definition

### HAL1201N

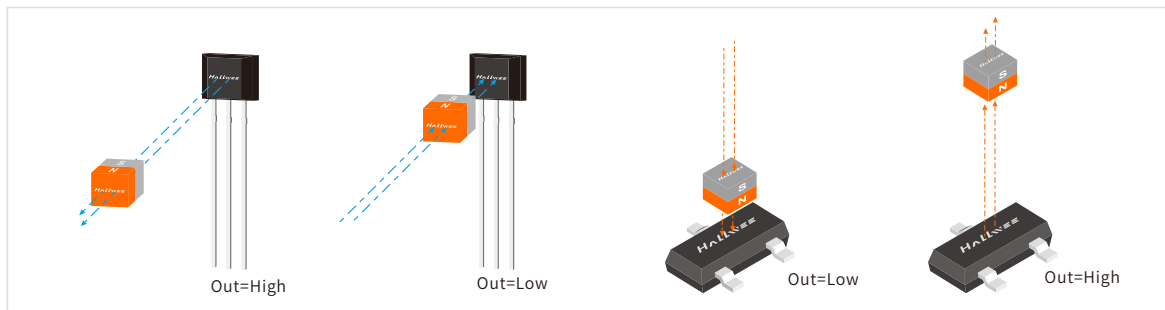

### HAL1202S

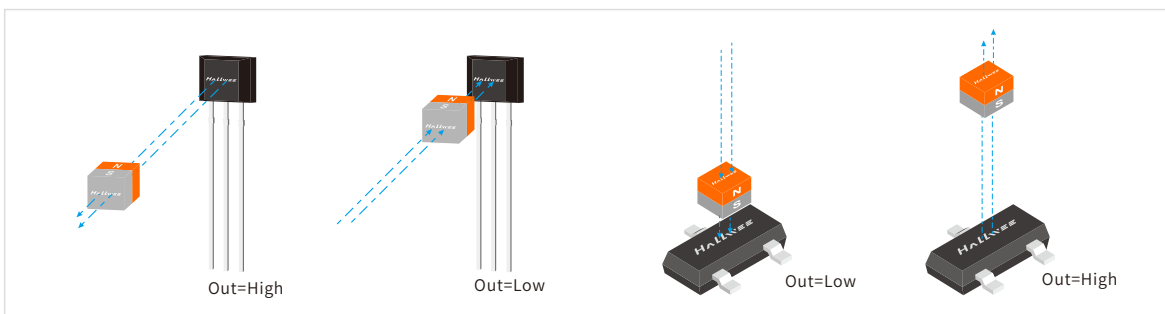

## 13. ESD Protection

Human Body Model (HBM) tests according to: Mil. Std. 883F method 3015.7

Parameter	Symbol	Limit Values		Unit	Notes
		Min	Max		
ESD Voltage	$V_{ESD}$		4	kV	

## 14. Performance Characteristics

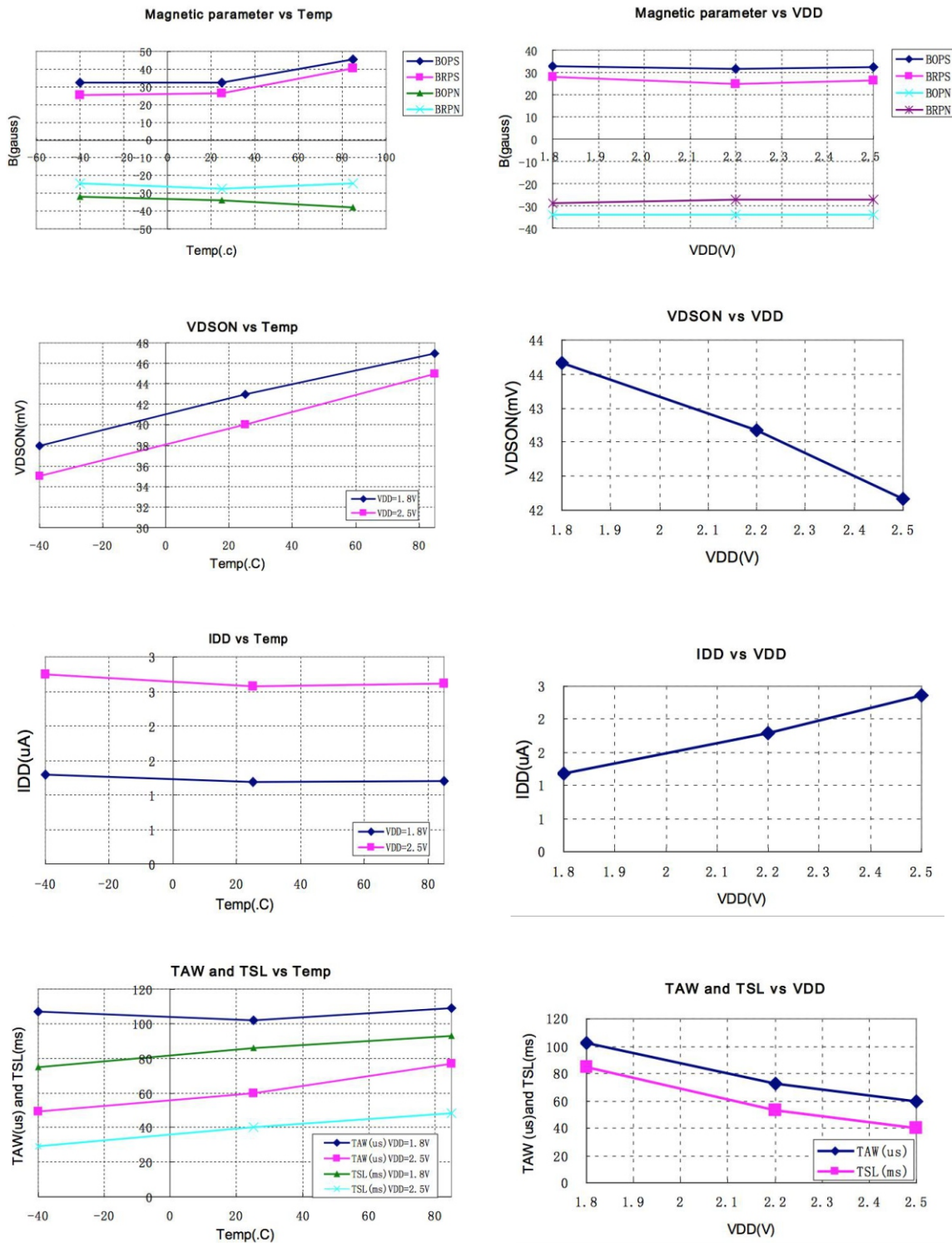



## 15. Unique Features

### CMOS Hall IC Technology

The chopper stabilized amplifier uses switched capacitor techniques to eliminate the amplifier offset voltage, which, in bipolar devices, is a major source of temperature sensitive drift. CMOS makes this advanced technique possible. The CMOS chip is also much smaller than a bipolar chip, allowing very sophisticated circuitry to be placed in less space. The small chip size also contributes to lower physical stress and less power consumption.

### Installation Comments

Consider temperature coefficients of Hall IC and magnetics , as well as air gap and life time variations.

Observe temperature limits during wave soldering. Typical IR solder-reflow profile:

No Rapid Heating and Cooling.

Recommended Preheating for max. 2minutes at 150 °C

Recommended Reflowing for max. 5seconds at 240 °C

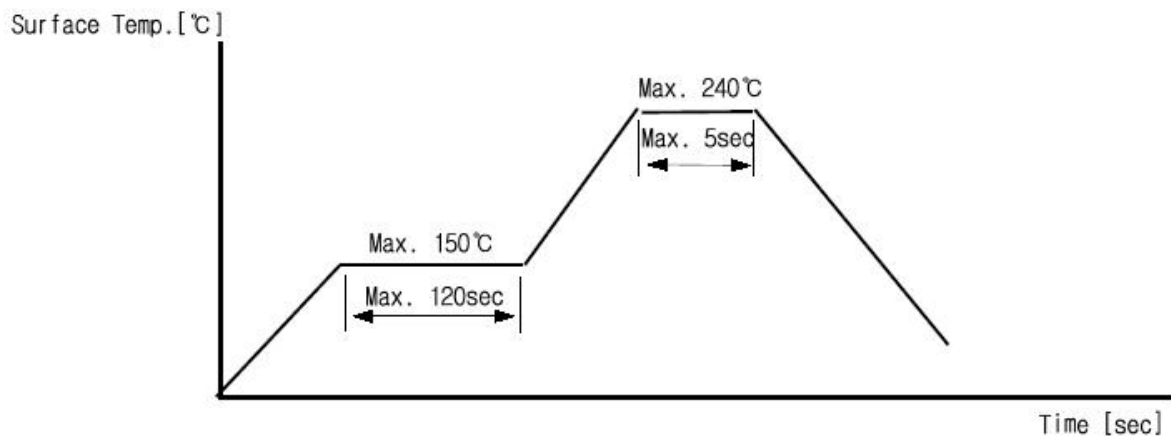

## 16. ESD Precautions

Electronic semiconductor products are sensitive to Electro Static Discharge (ESD). Always observe Electro Static Discharge control procedures whenever handling semiconductor products.

## 17. Order information

Part Number	Package Dimension	MPQ
HAL1201N SO	SO (SOT-23-3L)	3000PCS
HAL1201N UA	UA (TO-92S)	1000PCS
HAL1201N SO5	SO (SOT-553)	3000PCS
HAL1201N SW	SW (DFN1216)	4000PCS
HAL1202S SO	SO (SOT-23-3L)	3000PCS

## 18. Package Information

### SOT-23 Package Physical Characteristics

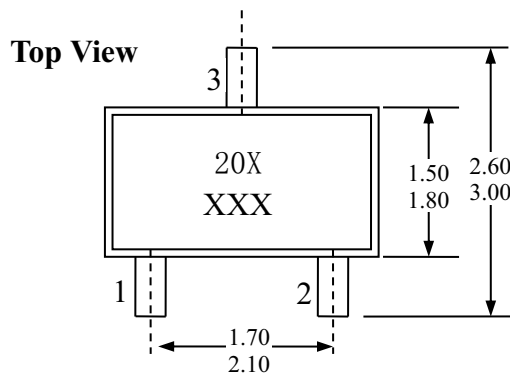

**Notes:**

- 1). PINOUT: **Pin 1 VDD**  
**Pin 2 Output**  
**Pin 3 GND**

2). All dimensions are in millimeters ;

**Marking:**

**20X** -- Code of Device ( HAL120X ) ;

**XX**: production code

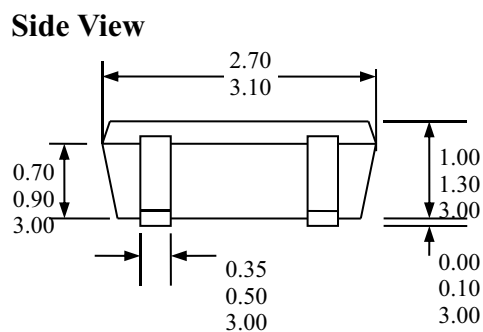

**End View**

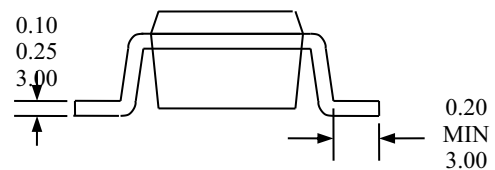

### SOT-23 Package Hall Location

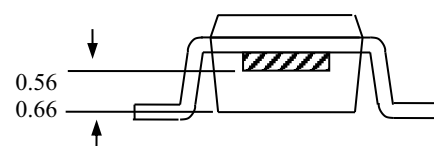
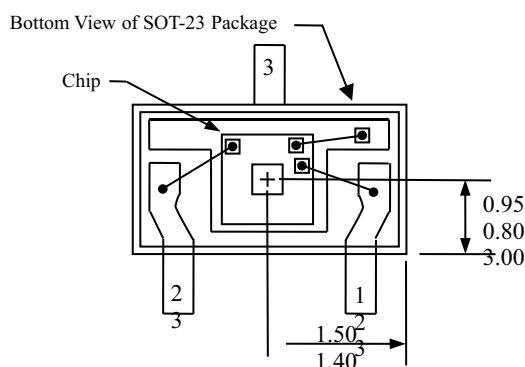

TO-92 Package Physical Characteristics

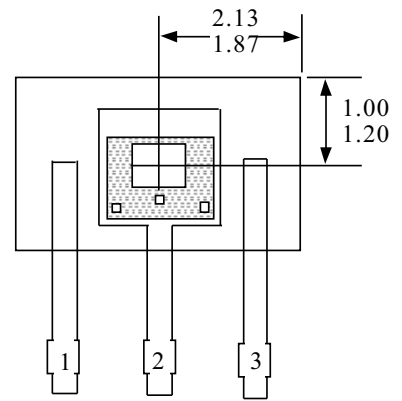
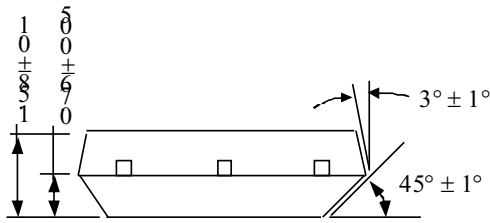

Sensor Location

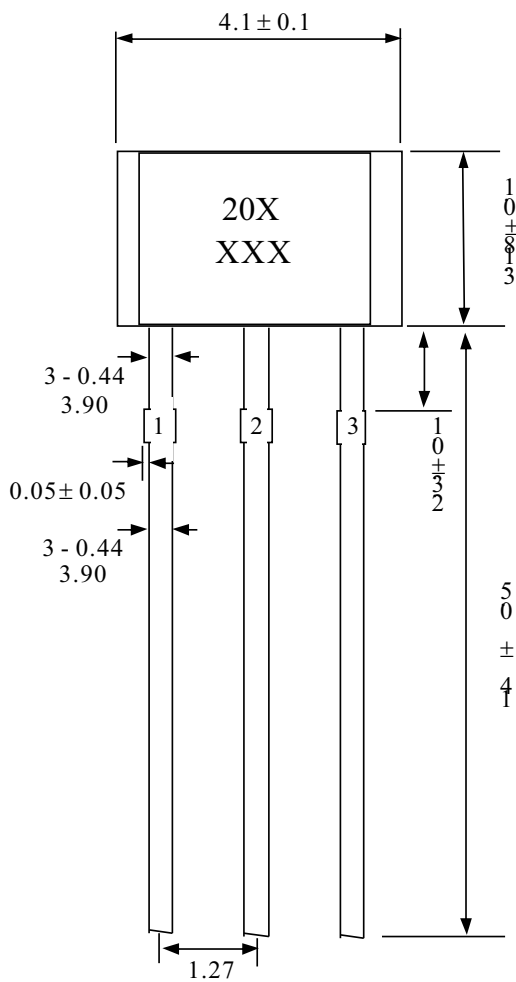

Active Area Depth: 0.84(Nom)

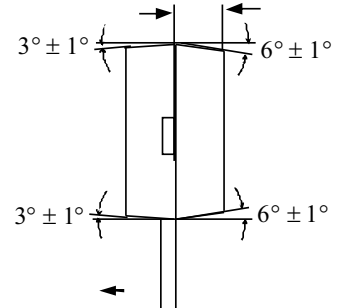

Notes:

- 1). Controlling dimension : mm ;
- 2). Leads must be free of flash and plating voids ;
- 3). Do not bend leads within 1 mm of lead to package interface ;
- 4). PINOUT: Pin 1 VDD  
Pin 2 GND  
Pin 3 Output

**DFN1216 Package Physical Characteristics**

DFN1216-4L

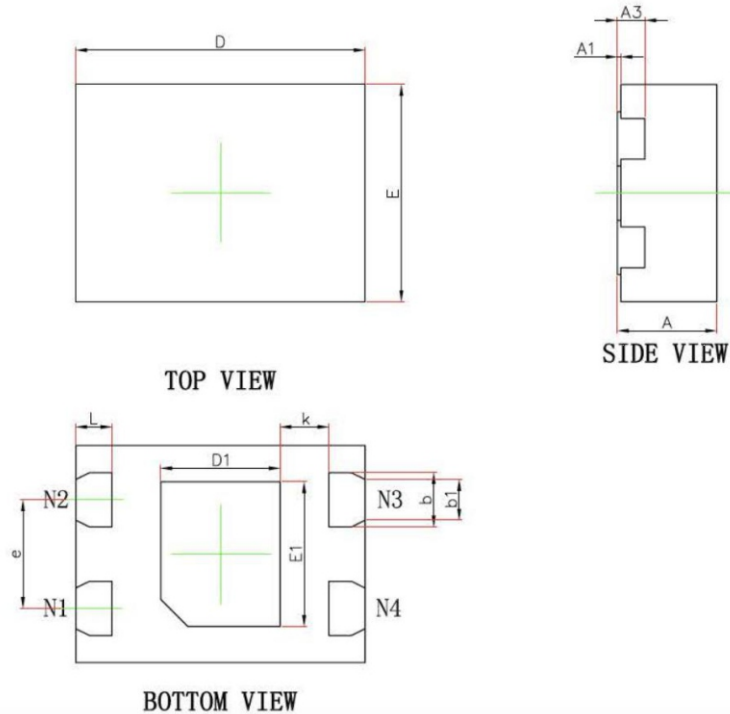

Symbol	Dimensions In Millimeters		Dimensions In Inches	
	MIN.	MAX.	MIN.	MAX.
A	0.500	0.600	0.020	0.024
A1	0.000	0.050	0.000	0.002
A3	0.152REF.		0.006REF.	
D	1.500	1.700	0.059	0.067
E	1.100	1.300	0.043	0.051
D1	0.560	0.760	0.022	0.030
E1	0.700	0.900	0.028	0.035
b	0.250	0.350	0.010	0.014
b1	0.175	0.275	0.007	0.011
e	0.650TYP.		0.024TYP.	
L	0.150	0.250	0.006	0.010
k	0.200MIN.		0.008TYP.	

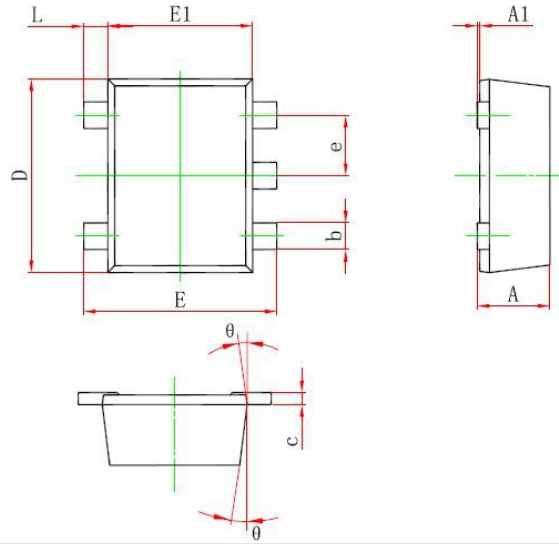
**SOT553 Package Physical Characteristics**

ymbol	Dimensions In Millimeters		Dimensions In Inches	
	Min.	Max.	Min.	Max.
A	0.525	0.600	0.021	0.024
A1	0.000	0.050	0.000	0.002
e	0.450	0.550	0.018	0.022
c	0.090	0.160	0.004	0.006
D	1.500	1.700	0.059	0.067
b	0.170	0.270	0.007	0.011
E1	1.100	1.300	0.043	0.051
E	1.500	1.700	0.059	0.067
θ	7°REF		7°REF	
L	0.100	0.300	0.004	0.012