

Silicon N-Channel Power MOSFE

Description

The MD70N10 uses advanced technology and design to provide excellent $R_{DS(ON)}$. It can be used in a wide variety of applications.

General Features

- ① $V_{DS}=100V$, $R_{ds(on)}<21m\Omega$ @ $V_{GS}=10V$, $I_D=70A$ ($T_{yp}:17m\Omega$)
- ② Fast switching
- ③ 100% avalanche tested
- ④ Improved dv/dt capability

Application

- ① Switch Mode Power Supply (SMPS)
- ② Uninterruptible Power Supply (UPS)
- ③ Power Factor Correction (PFC)

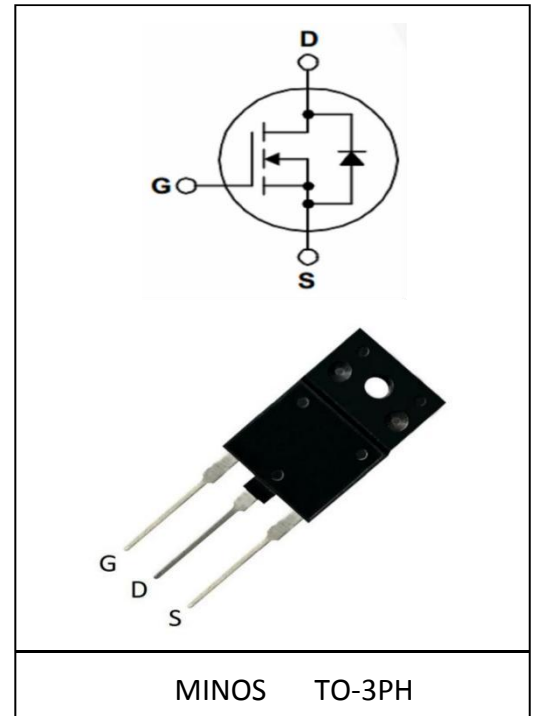

Package Marking And Ordering Information:

Ordering Codes	Package	Product Code	Packing
MD70N10	TO-3PH	MD70N10	Tube

Electrical Characteristics @ $T_a=25^\circ C$ (unless otherwise specified)

Parameter	Symbol	Value	Unit
		TO-3P	
Drain-Source Voltage ($V_{GS} = 0V$)	V_{DSS}	100	V
Continuous Drain Current	I_D	70	A
Pulsed Drain Current (note1)	I_{DM}	Figure 6	A
Gate-Source Voltage	V_{GSS}	± 20	V
Single Pulse Avalanche Energy (note2)	E_{AS}	1943	mJ
Avalanche Current (note1)	I_{AR}	32	A
Repetitive Avalanche Energy (note1)	E_{AR}	36	mJ

Power Dissipation (TC = 25°C)	P_D	200	W
Operating Junction and Storage Temperature Range	T_J, T_{stg}	-55 to 175	°C

Thermal Resistance

Parameter	Symbol	Value	Unit
		TO-3P	
Thermal Resistance, Junction-to-Case	R_{thJC}	0.75	°C/W
Thermal Resistance, Junction-to-Ambient	R_{thJA}	62	

Specifications $T_J = 25^\circ\text{C}$, unless otherwise noted

Parameter	Symbol	Test Conditions	Value			Unit
			Min.	Typ.	Max.	
Drain-Source Breakdown Voltage	$V_{(BR)DSS}$	$V_{GS} = 0V, I_D = 250\mu A$	100	--	--	V
Zero Gate Voltage Drain Current	I_{DSS}	$V_{DS} = 100V, V_{GS} = 0V, T_J = 25^\circ\text{C}$	--	--	1	μA
		$V_{DS} = 80V, V_{GS} = 0V, T_J = 125^\circ\text{C}$	--	--	100	
Gate-Source Leakage	I_{GSS}	$V_{GS} = +20V, V_{DS} = 0V$	--	--	100	nA
		$V_{GS} = -20V, V_{DS} = 0V$	--	--	-100	
Gate-Source Threshold Voltage	$V_{GS(th)}$	$V_{DS} = V_{GS}, I_D = 250\mu A$	2.0	--	4.0	V
Drain-Source On-Resistance (Note3)	$R_{DS(on)}$	$V_{GS} = 10V, I_D = 28A$	--	17	21	m Ω
Forward Transconductance	g_{fs}	$V_{DS} = 10V, I_D = 28A$		85		S
Input Capacitance	C_{iss}	$V_{GS} = 0V, V_{DS} = 25V, f = 1.0\text{MHz}$	--	2700	--	pF
Output Capacitance	C_{oss}		--	610	--	
Reverse Transfer Capacitance	C_{rss}		--	260	--	
Total Gate Charge	Q_g	$V_{DD} = 50V, I_D = 28A, V_{GS} = 0 \text{ to } 10V$	--	60	--	nC
Gate-Source Charge	Q_{gs}		--	15	--	
Gate-Drain Charge	Q_{gd}		--	45	--	
Turn-on Delay Time	$t_{d(on)}$	$V_{DD} = 50V, I_D = 28A, V_{GS} = 10V$ $R_G = 2.5 \Omega$	--	20	--	ns
Turn-on Rise Time	t_r		--	28	--	
Turn-off Delay Time	$t_{d(off)}$		--	65	--	
Turn-off Fall Time	t_f		--	15	--	



迈诺斯科技

MD70N10

Continuous Body Diode Current	I_S	$T_C = 25\text{ }^\circ\text{C}$	--	--	70	A
Pulsed Diode Forward Current	I_{SM}		--	--	230	
Body Diode Voltage	V_{SD}	$T_J = 25\text{ }^\circ\text{C}, I_{SD} = 28\text{A}, V_{GS} = 0\text{V}$	--	--	1.5	V
Reverse Recovery Time	t_{rr}	$V_{GS} = 0\text{V}, I_S = 28\text{A},$ $d_{iF}/d_t = 100\text{A}/\mu\text{s}$	--	195	--	ns
Reverse Recovery Charge	Q_{rr}		--	107	--	μC

Notes

1. Repetitive Rating: Pulse width limited by maximum junction temperature
2. $I_{AS} = 30\text{A}, V_{DD} = 50\text{V}, R_G = 25\ \Omega$, Starting $T_J = 25\text{ }^\circ\text{C}$
3. Pulse Test: Pulse width $\leq 300\mu\text{s}$, Duty Cycle $\leq 1\%$

Typical Characteristics $T_J = 25^\circ\text{C}$, unless otherwise noted

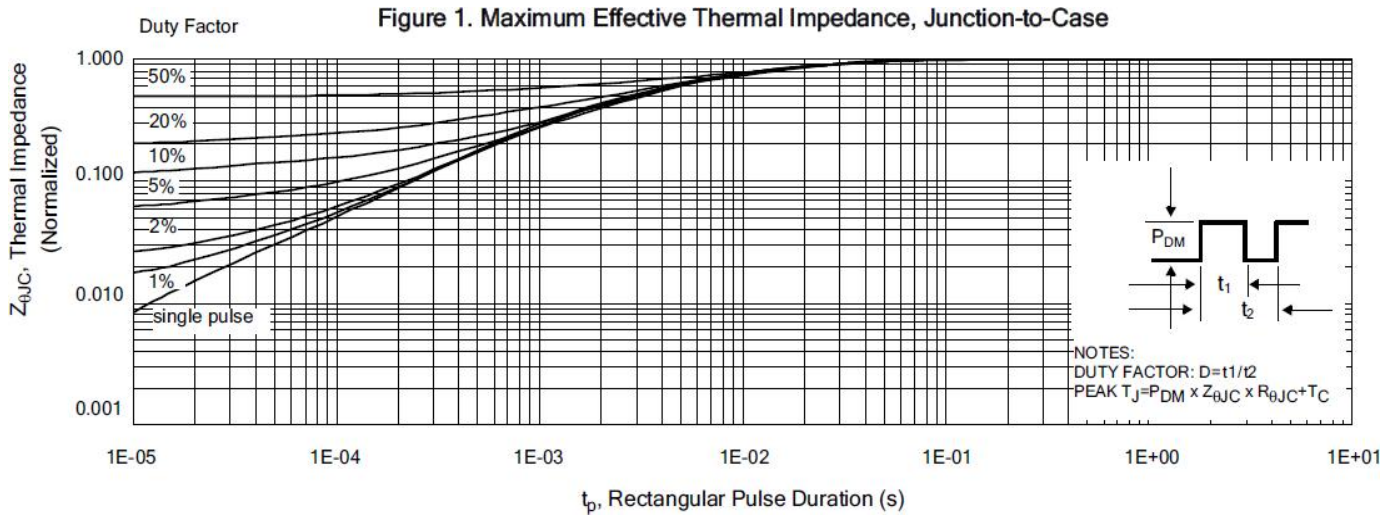

Figure 2. Maximum Power Dissipation vs Case Temperature

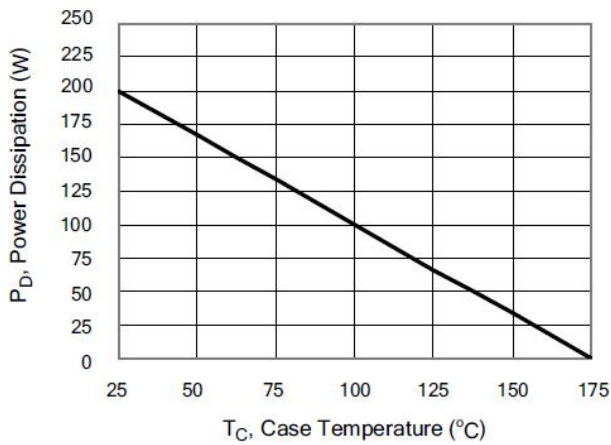

Figure 3. Maximum Continuous Drain Current vs Case Temperature

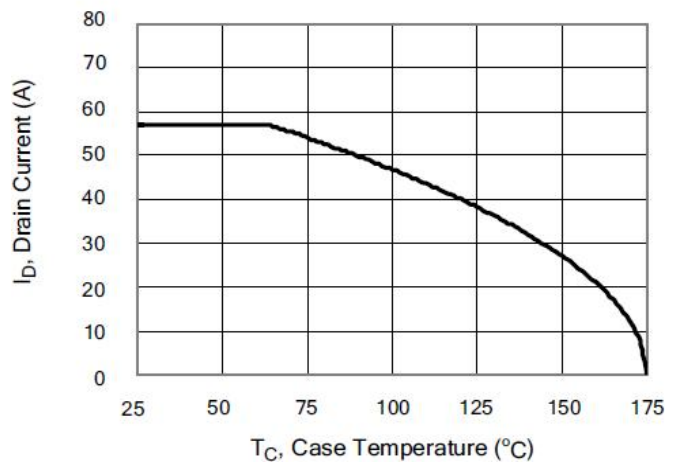

Figure 4. Typical Output Characteristics

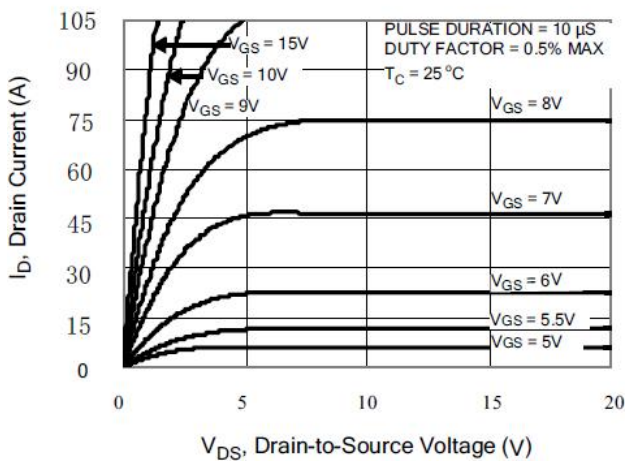
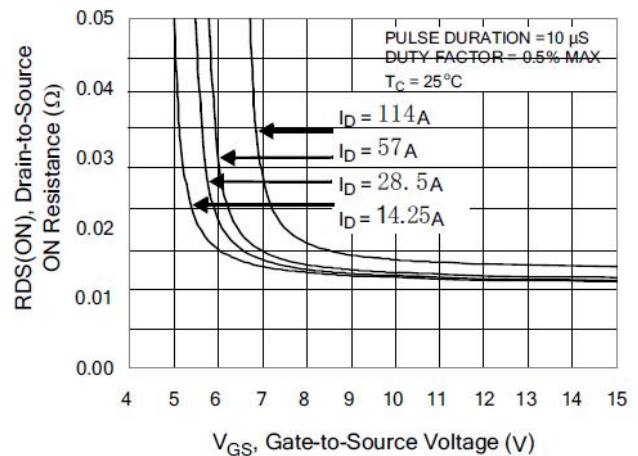

Figure 5. Typical Drain-to-Source ON Resistance vs Gate Voltage and Drain Current



Typical Characteristics $T_J = 25^\circ\text{C}$, unless otherwise noted

Figure 6. Maximum Peak Current Capability

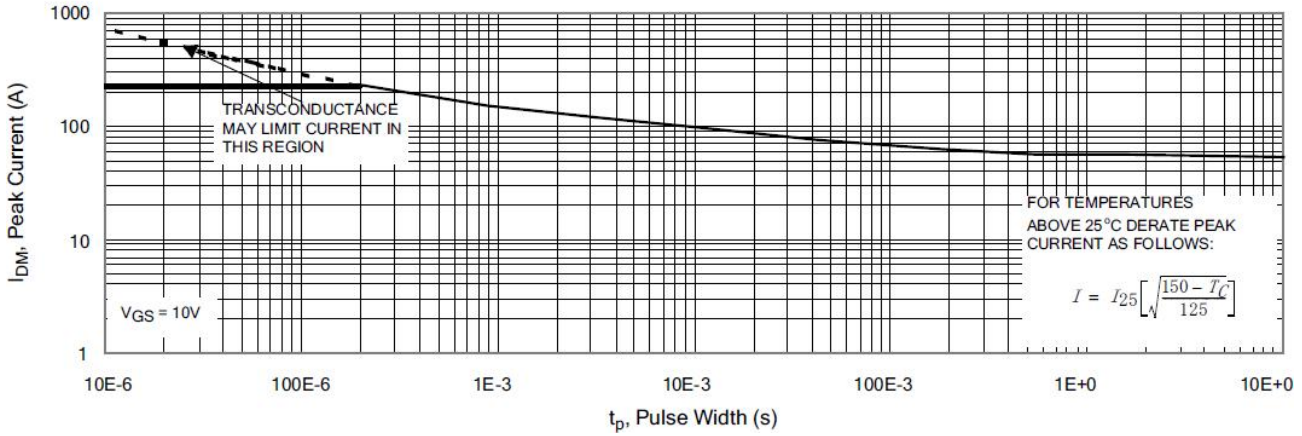

Figure 7. Typical Transfer Characteristics

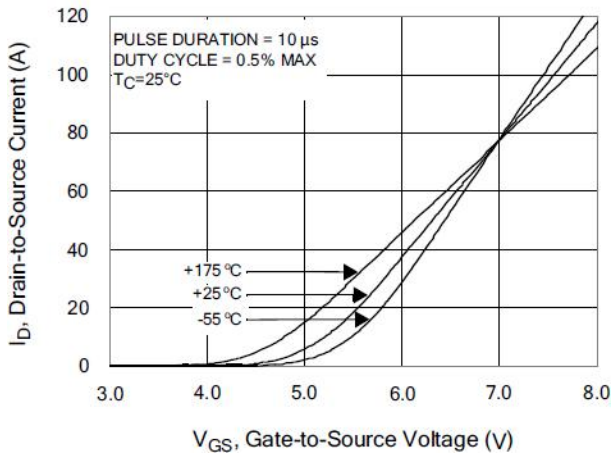

Figure 8. Unclamped Inductive Switching Capability

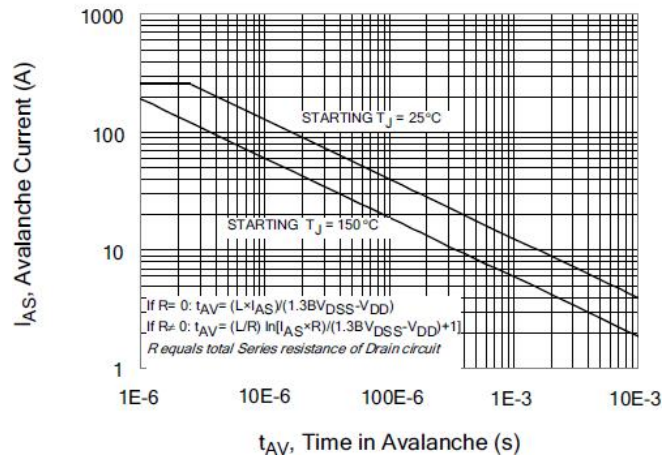

Figure 9. Typical Drain-to-Source ON Resistance vs Drain Current

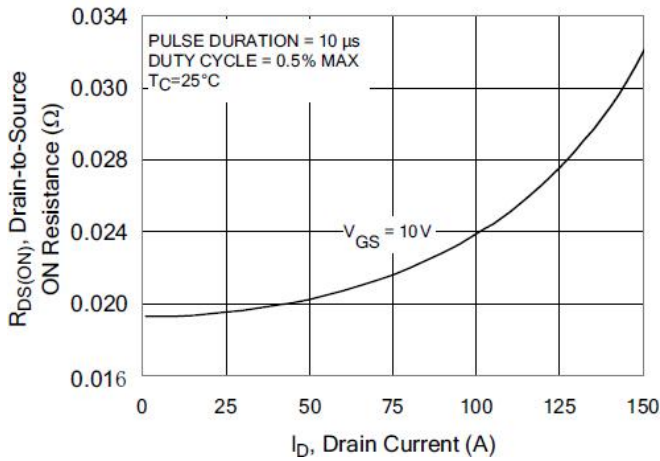
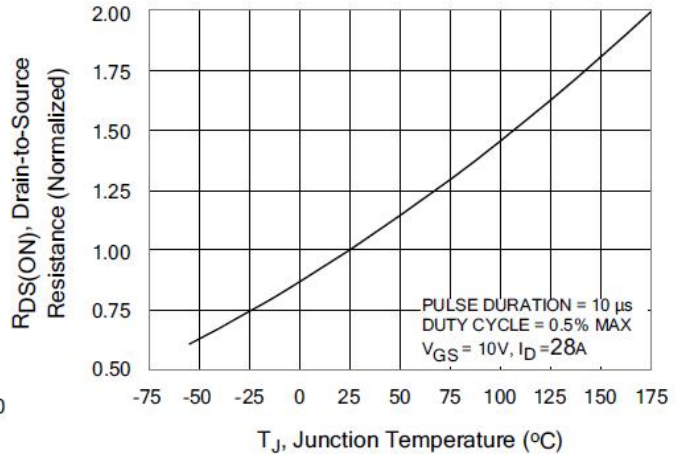

Figure 10. Typical Drain-to-Source ON Resistance vs Junction Temperature



Typical Characteristics $T_J = 25^\circ\text{C}$, unless otherwise noted

Figure 11. Typical Breakdown Voltage vs Junction Temperature

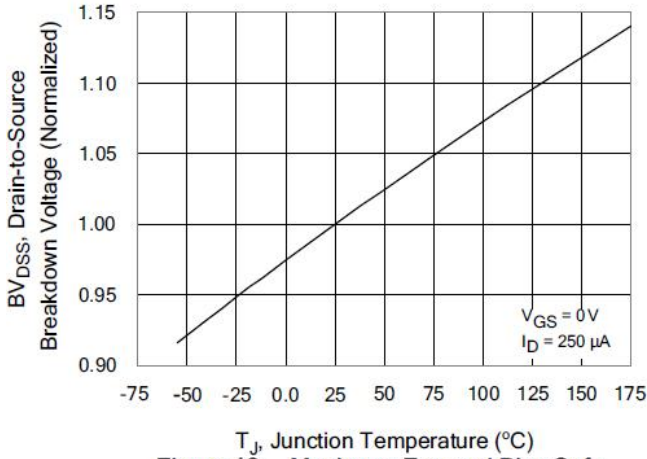

Figure 12. Typical Threshold Voltage vs Junction Temperature

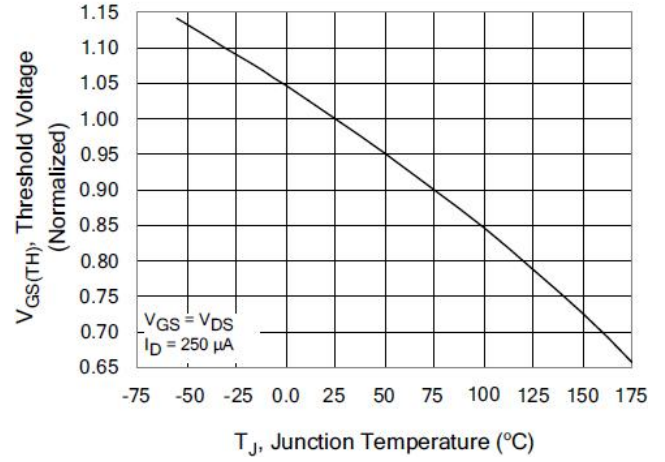

Figure 13. Maximum Forward Bias Safe Operating Area

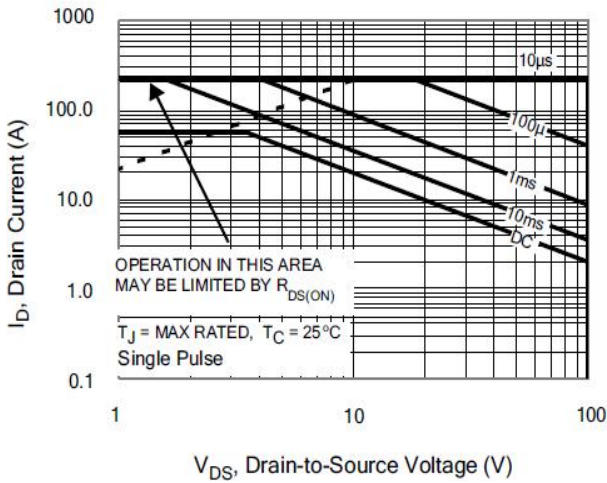

Figure 14. Capacitance vs Vds

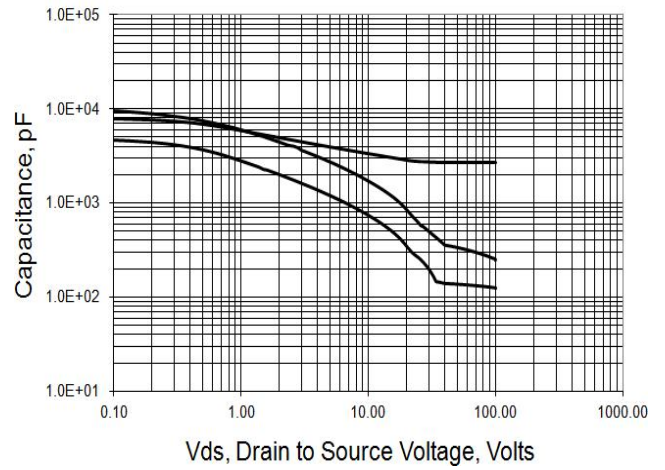

Figure 15. Typical Gate Charge

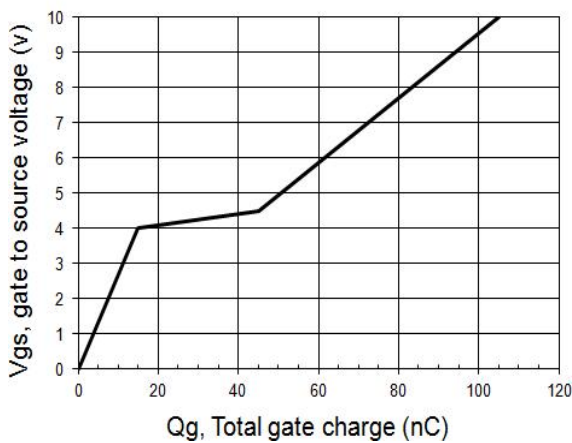

Figure 16. Typical Body Diode Transfer Characteristics

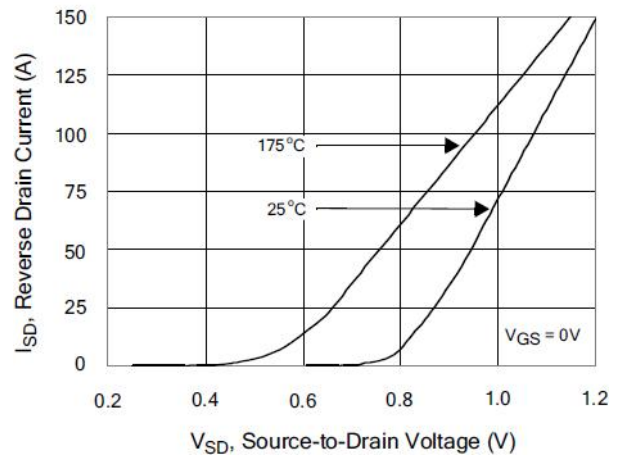

Figure A: Gate Charge Test Circuit and Waveform

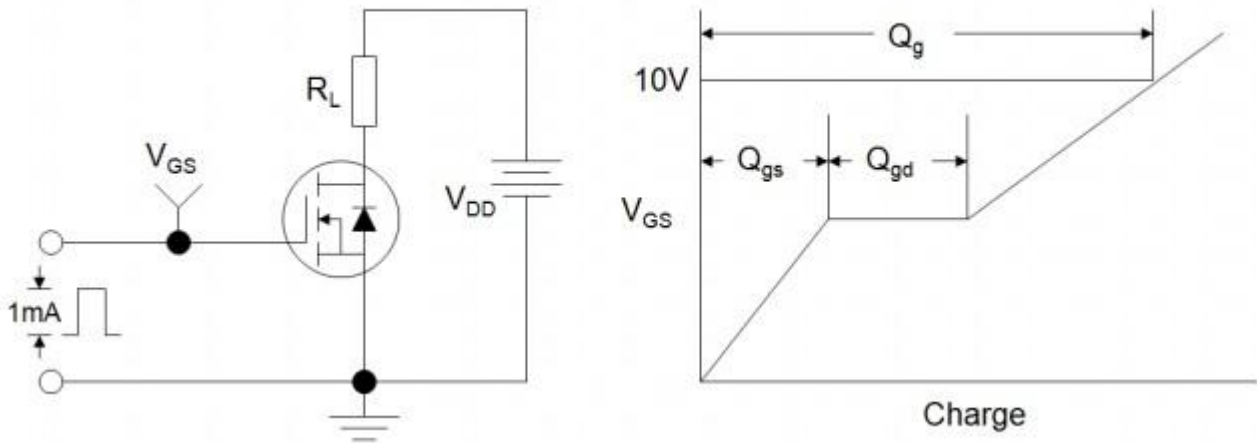

Figure B: Resistive Switching Test Circuit and Waveform

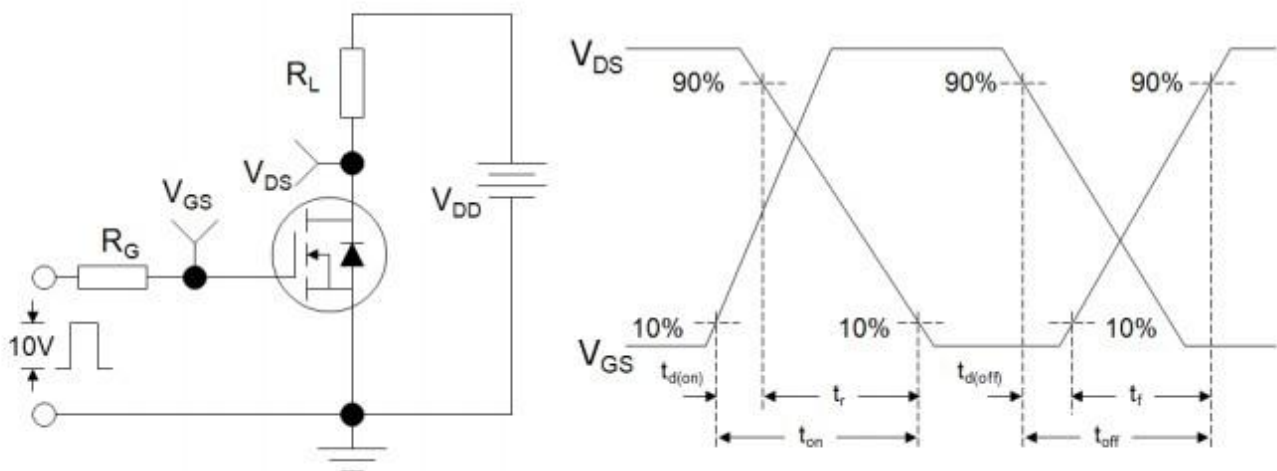
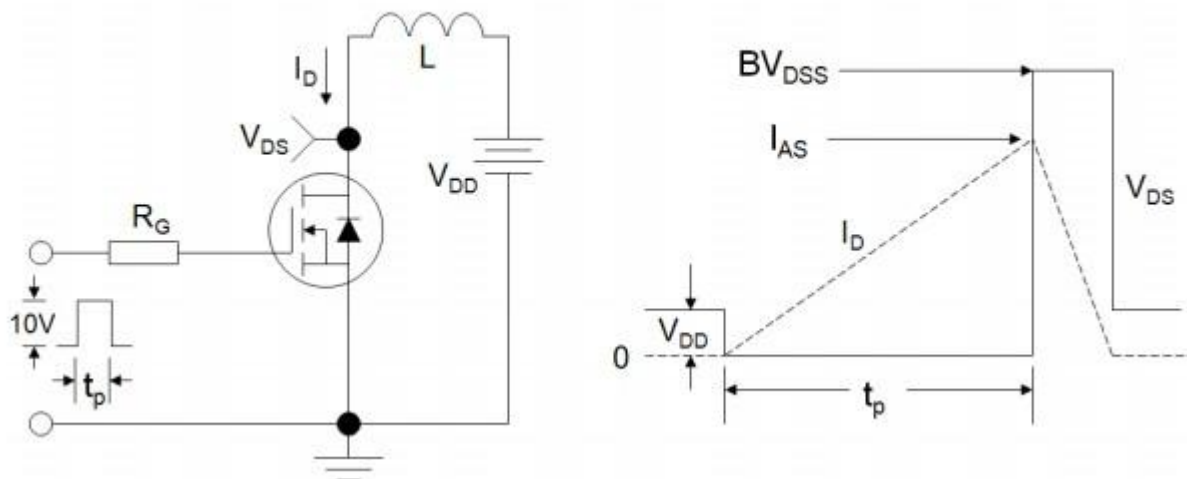
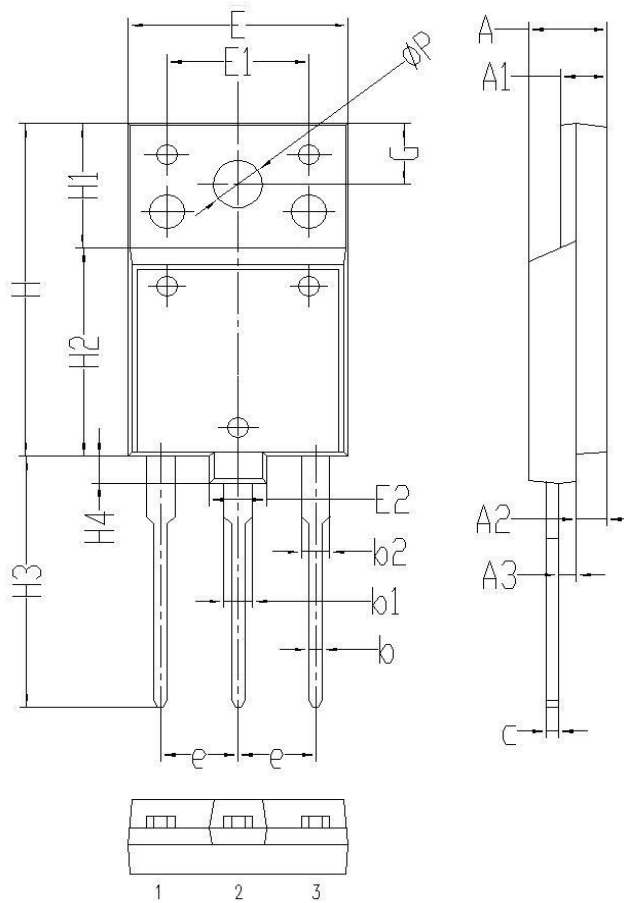

Figure C: Unclamped Inductive Switching Test Circuit and Waveform



Package Description

TO-3PH PACKAGE



Symbol	单位 mm		
	Min	Nom	Max
A	5.35	5.55	5.75
A1	2.80	3.00	3.20
A2	1.90	2.10	2.30
A3	1.10	1.30	1.50
b	0.65	0.75	0.85
b1	1.80	2.00	2.20
b2	1.80	2.00	2.20
c	0.70	0.90	1.10
e	5.25	5.45	5.65
E	15.3	15.5	15.7
E1	9.80	10.0	10.2
E2	3.80	4.00	4.20
H	24.3	24.5	24.7
H1	9.00	9.20	9.40
H2	15.1	15.3	15.5
H3	18.5	19.0	19.5
H4	1.80	2.00	2.20
H5	4.80	5.00	5.20
G	4.3	4.5	4.7
ΦP	3.40	3.60	3.80



NOTE:

1. Exceeding the maximum ratings of the device in performance may cause damage to the device, even the permanent failure, which may affect the dependability of the machine. Please do not exceed the absolute maximum ratings of the device when circuit designing.
2. When installing the heat sink, please pay attention to the torsional moment and the smoothness of the heat sink.
3. MOSFETs is the device which is sensitive to the static electricity, it is necessary to protect the device from being damaged by the static electricity when using it.
4. Shenzhen Minos reserves the right to make changes in this specification sheet and is subject to change without prior notice.

CONTACT:

深圳市迈诺斯科技有限公司（总部）

地址：深圳市福田区华富街道田面社区深南中路4026号田面城市大厦22B-22C

邮编：518025

电话：0755-83273777