

## 1.6V – 3.6V, 1x Ultra Low Power Mobile EMI Reduction IC

### Features

- FCC approved method of EMI attenuation.
- Generates a 1X low EMI Phase Modulated replication of the input signal.
- Vdd 1.6V - 3.6V, 20 MHz to 38 MHz
- Multiple Deviation Options
- 4-pin  $\mu$ DFN package
- Slow rate controlled buffer for enhanced EMI reduction
- Operating Temperature  $-40^{\circ}\text{C}$  to  $125^{\circ}\text{C}$  for Automotive AEC-Q100

### Product Description

The LC46X products are versatile 1x Active EMI management IC's designed to provide system wide reduction of Electromagnetic Interference (EMI) and Radio Frequency Interference (RFI) from clock and data sources. This allows significant system cost savings by reducing the number of circuit board layers, ferrite beads, shielding and other passive components that are traditionally required to pass EMI regulations. The LC46X family of mobile active EMI management

ICs is unique in it's design and is based on LFC's proprietary "Sa $\Phi$ ic™" phase controlled Active EMI management technology. This allows operation on aperiodic as well as periodic signals. By the precise placement of the edges of the reconstructed input signal, the peak energy of the output is distributed over a wider and controlled energy band thereby significantly lowering system EMI compared to the typical narrow band signal produced by oscillators and most frequency generators.

The LC464 has an input frequency range of 20 MHz to 38MHz over a wide voltage range of 1.6V to 3.6V. The device has only 4 pins providing the smallest footprint ideally suited for mobile and space constrained applications..

The device is available in a 4-pin  $\mu$ DFN package.

### Applications

The LC46X series is targeted towards LED displays, Camera modules, Cell phones, MIDs, Netbooks and numerous other "power and space" sensitive applications.

### Block Diagram

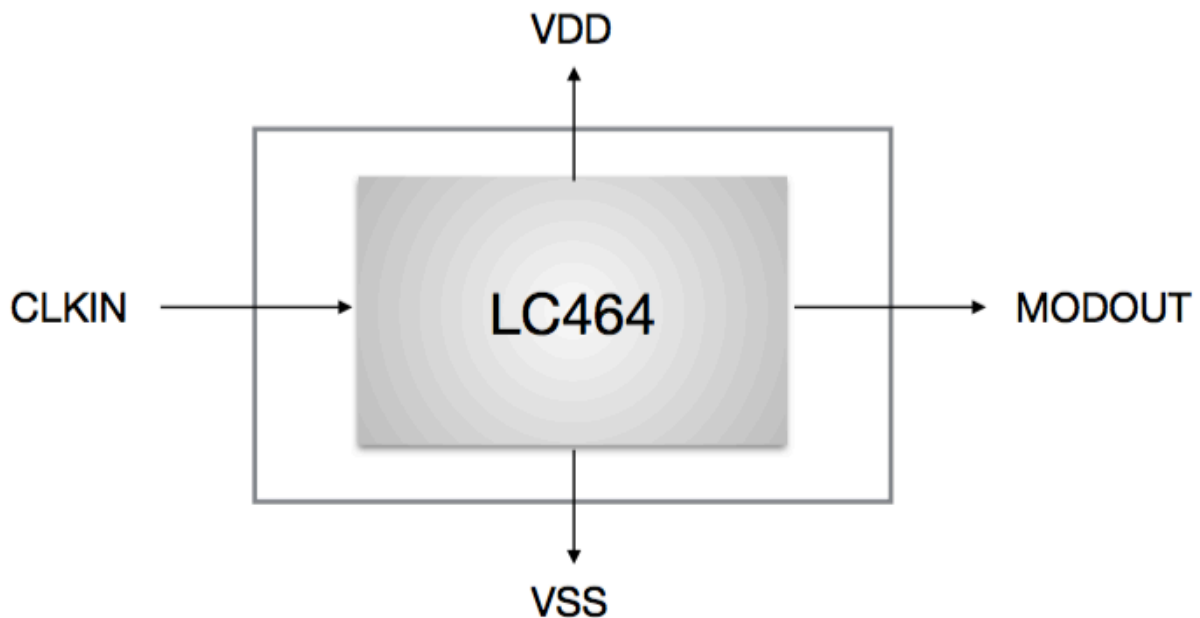

## Pin Configuration

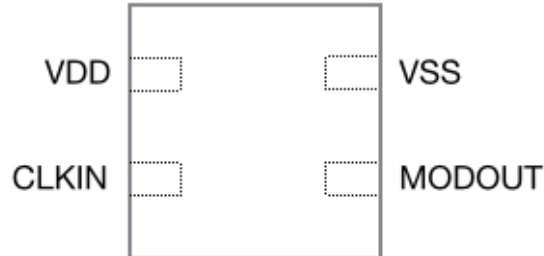

## Pin Description

Pin#	Pin Name	Type	Description
1	VDD	P	System Power Supply pin
2	CLKIN	I	Clock input
3	MODOUT	O	1X phase modulated buffered output.
4	VSS	P	System ground reference input.

## Operating Conditions

Parameter	Description	Min	Max	Unit
$V_{DD(3.3V)}$	Supply Voltage	1.6	3.6	V
$T_A$	Operating Temperature (Ambient Temperature)	-40	+125	°C
$C_L$	Load Capacitance		20	pF
$C_{IN}$	Input Capacitance		5	pF

## Absolute Maximum Rating

Symbol	Parameter	Rating	Unit
$V_{in}$	Voltage on any pin with respect to Ground	-0.5 to +4.6	V
$T_{STG}$	Storage temperature	-65 to +125	°C
$T_s$	Max. Soldering Temperature (10 sec)	260	°C
$T_J$	Junction Temperature	150	°C
$T_{DV}$	Static Discharge Voltage (As per JEDEC STD22- A114-B)	2	KV

Note: These are stress ratings only and are not implied nor guaranteed for functional use. Exposure to absolute maximum ratings for prolonged periods of time may affect device reliability.

**Functional Table**

Part Number	Freq. Range (MHz)	Freq. (MHz)	Deviation (%)
LC464(1.8V)	20~38	24	±0.43
		27	±0.48
		37	±0.50
LC464(3.3V)	20~38	24	±0.25
		27	±0.27
		37	±0.28

Note: Specified at VDD 1.8V/3.3V and room temperature. Frequency deviation can vary over voltage and temperature by +/-20%

**DC Electrical Characteristics (1.8 +/-0.2V)**

Parameter	Description	Test Conditions	Min	Typ	Max	Unit
V <sub>DD</sub>	Supply Voltage		1.6	1.8	2.0	V
V <sub>IH</sub>	Input HIGH Voltage		0.66*V <sub>DD</sub>			V
V <sub>IL</sub>	Input LOW Voltage				0.33*V <sub>DD</sub>	V
I <sub>IH</sub>	Input HIGH Current (pin 1)	V <sub>IN</sub> = V <sub>DD</sub>			10	µA
I <sub>IL</sub>	Input LOW Current (pin 1)	V <sub>IN</sub> = 0V			10	µA
V <sub>OH</sub>	Output HIGH Voltage	I <sub>OH</sub> = -4mA	0.75*V <sub>DD</sub>			V
V <sub>OL</sub>	Output LOW Voltage	I <sub>OL</sub> = +4mA			0.25*V <sub>DD</sub>	V
I <sub>CC</sub>	Static Supply Current	CLKIN = VSS or VDD		0.1	1.0	µA
I <sub>DD</sub>	Dynamic Supply Current	27 MHz	Unloaded	3.0	4.0	mA
			10 pF load	3.5	4.5	
Z <sub>o</sub>	Output Impedance			25		Ω

**Switching Characteristics (1.8V +/-0.2V)**

Parameter	Description	Test Conditions	Min	Typ	Max	Unit
INPUT	Input Frequency		20	24	38	MHz
MODOUT	Output Frequency		20	24	38	
T <sub>d</sub>	Duty Cycle <sup>1,2</sup> = (t <sub>2</sub> / t <sub>1</sub> ) * 100	Measured at V <sub>DD</sub> / 2	45	50	55	%
t <sub>3</sub>	Output Rise Time <sup>1,2</sup>	Measured between 20% to 80%	1.0	2.0	3.0	nS
t <sub>4</sub>	Output Fall Time <sup>1,2</sup>	Measured between 80% to 20%	1.0	1.8	3.0	nS
t <sub>j</sub>	Cycle-to-cycle jitter <sup>2</sup>	No spreading unloaded outputs 27 MHz		±150		pS

Notes:

1. All parameters specified with 27MHz without loaded outputs and V<sub>DD</sub> 1.8V.

2. Parameter is guaranteed by design and characterization. Not 100% tested in production

**DC Electrical Characteristics (3.3 +/-0.3V)**

Parameter	Description	Test Conditions	Min	Typ	Max	Unit
V <sub>DD</sub>	1		3.0	3.3	3.6	V
V <sub>IH</sub>	Input HIGH Voltage		0.66*V <sub>DD</sub>			V
V <sub>IL</sub>	Input LOW Voltage				0.33*V <sub>DD</sub>	V
I <sub>IH</sub>	Input HIGH Current (pin 1)	V <sub>IN</sub> = V <sub>DD</sub>			10	μA
I <sub>IL</sub>	Input LOW Current (pin 1)	V <sub>IN</sub> = 0V			10	μA
V <sub>OH</sub>	Output HIGH Voltage	I <sub>OH</sub> = -8mA	0.75*V <sub>DD</sub>			V
V <sub>OL</sub>	Output LOW Voltage	I <sub>OL</sub> = +8mA			0.25*V <sub>DD</sub>	V
I <sub>CC</sub>	Static Supply Current	CLKIN = VSS or VDD		0.1	1.0	μA
I <sub>DD</sub>	Dynamic Supply Current	27 MHz	Unloaded	6	7	mA
			10 pF load	7	8	
Z <sub>o</sub>	Output Impedance			25		Ω

**Switching Characteristics (3.3V +/-0.3V)**

Parameter	Description	Test Conditions	Min	Typ	Max	Unit
INPUT	Input Frequency		20	24	38	MHz
MODOUT	Output Frequency		20	24	38	
T <sub>d</sub>	Duty Cycle <sup>1,2</sup> = (t <sub>2</sub> / t <sub>1</sub> ) * 100	Measured at V <sub>DD</sub> /2	45	50	55	%
t <sub>3</sub>	Output Rise Time <sup>1,2</sup>	Measured between 20% to 80%	0.6	1.5	2.5	nS
t <sub>4</sub>	Output Fall Time <sup>1,2</sup>	Measured between 80% to 20%	0.6	1.5	2.5	nS
t <sub>j</sub>	Cycle-to-cycle jitter <sup>2</sup>	No spreading unloaded outputs 27 MHz		±150		pS

Notes:

 1. All parameters specified with 27MHz without loaded outputs and V<sub>DD</sub> 3.3V.

2. Parameter is guaranteed by design and characterization. Not 100% tested in production

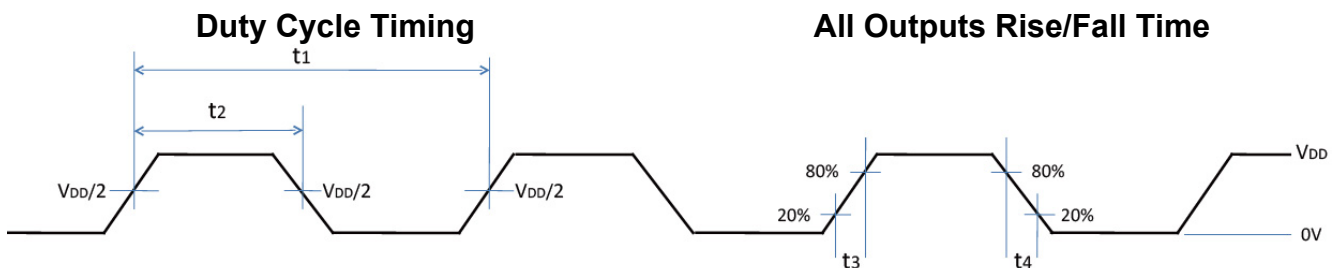

### Application Schematic

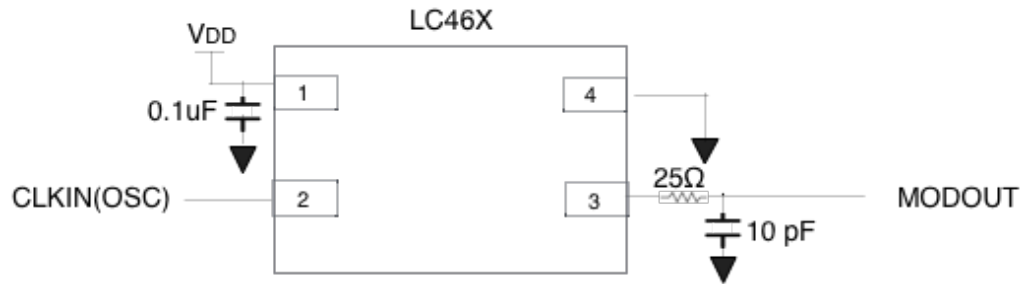

### Marking Information



X : Part Number  
YY : Traceability Code

### Ordering Information

Part Number	Tem. Indicator	Temp. Grade	Temp. Range	IC Marking	IC Package	Tape & Reel
LC464C	C	Commercial	0°~70°C	A	uDFN 1mm x 1mm	8,000 pcs/Reel
LC464I	I	Industrial	-20°~85°C	B		
LC464E	E	AEC-Q100 G2	-40°~105°C	C		
LC464A	A	AEC-Q100 G1	-40°~125°C	D		

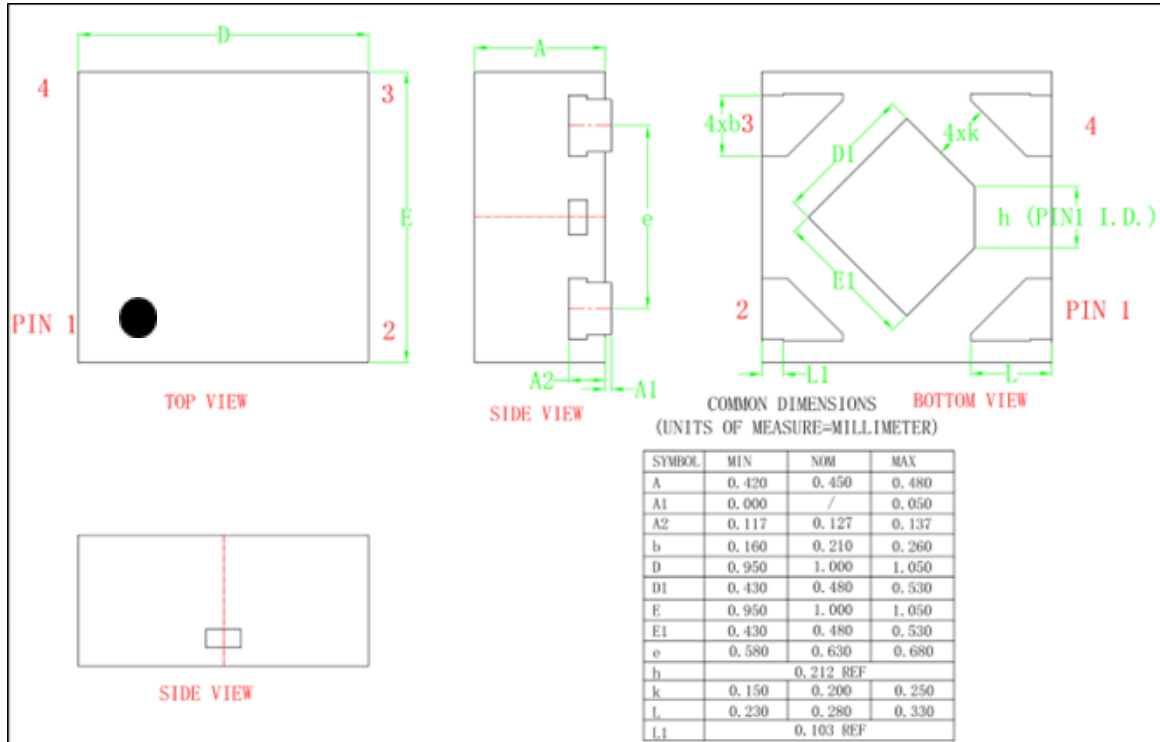
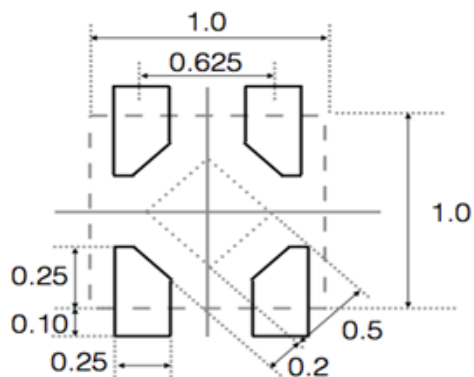
**Package Dimension  
uDFN**

**Recommended footprint**

**Revision History**

Revision Number	Date of Release	Changes
1.1	4/15/2019	1) Input frequency range 2) Update ordering information
1.2	6/24/2019	1) Deviation updates
1.3	7/2/2019	1) Deviation updates
1.4	10/7/2019	1) IC marking updates 2) $I_{IH}$ and $I_{IL}$ updates
1.5	12/10/2019	1) Minimum/Maximum $T_A$ update in operating conditions
1.6	7/16/2020	1) $t_3/t_4$ updates
1.7	12/24/2021	1) pdate the package dimension