

4 3 2 1

D
C
B
A

D
C
B
A

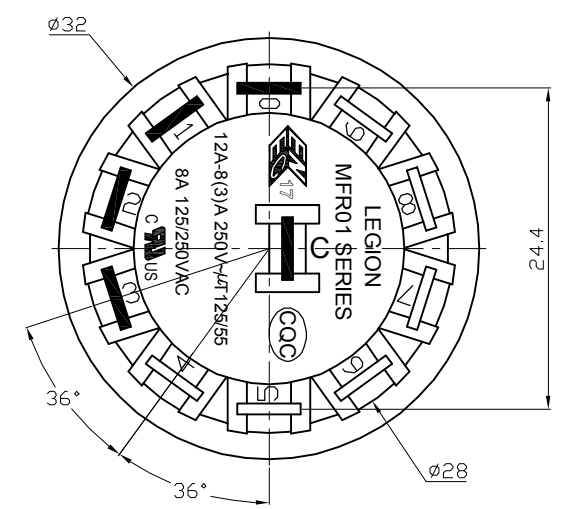
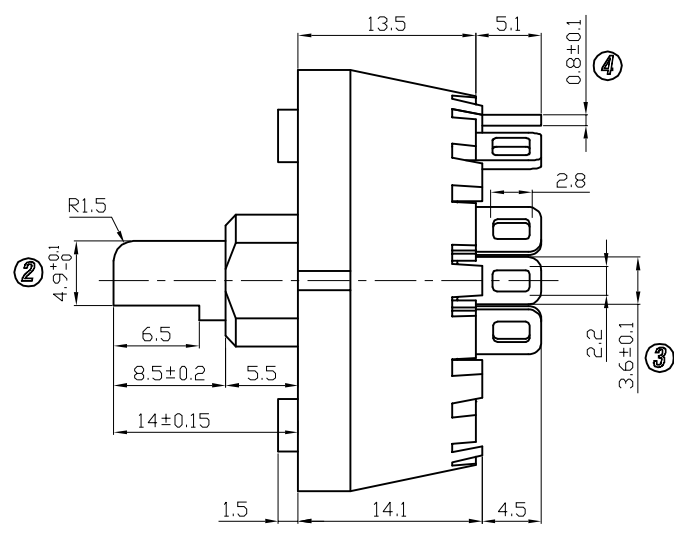
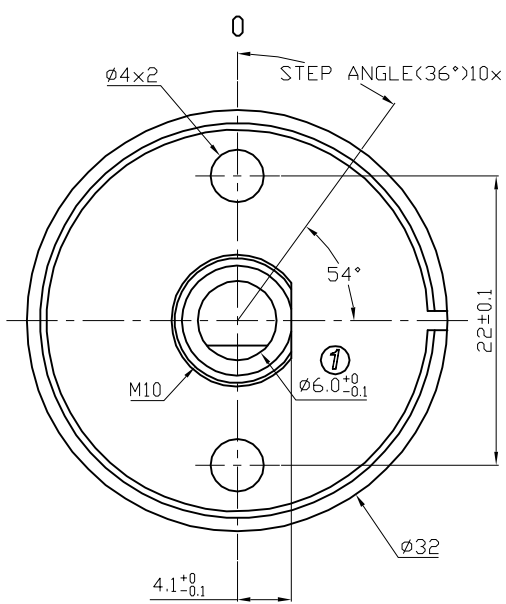

1. 额定值 RATING: 8A 125/250VAC (UL, C-UL)
12A-8(3)A 250V~ μ T125/55 (ENEC-17, CQC, CB)
2. 功能 FUNCTIONAL: 见电路图 SEE CIRCUIT DESCRIPTION
3. 接触电阻 CONTACT RESISTANCE: <50mΩ
4. 绝缘电阻 INSULATION RESISTANCE: >100MΩ (500VDC BETWEEN OPEN CONTACTS)
5. 耐电压 DIELECTRIC STRENGTH: >1500VAC 0.5mA 1 MINUTE
6. 所有部件均使用环保材料
ALL MATERIALS USE IN CONFORMIY WITH THE RoHS DIRECTIVE

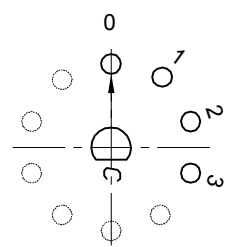

CIRCUIT DIAGRAM

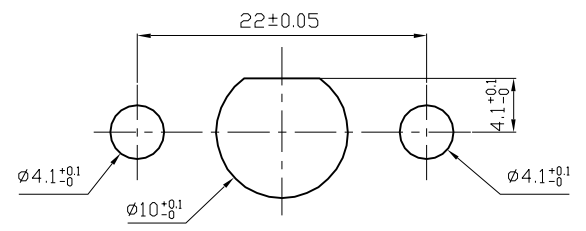

PANEL CUTOUT

5	→	10	→	DIMENSIONAL TOLERANCES		APPROVED	CHECKED	DESIGN	DRAWN	ALL SIZE ARE IN	MM		
4	→	9	→	RANGE	TOLERANCE				LMC	SCALE	NO		
3	→	8	→	X	±0.30				2019.05.20	MAT'L	***	DRAWING NO.	REV.
2	→	7	→	X.X	±0.20	LEGION ELECTRONIC & HARDWARE CO., LTD.				MATERIAL NO.	WIF121021		
1	→	6	→	X.XX	±0.10								
NO	DESCRIPTION	NO	DESCRIPTION	ANGLES	±1°								

4 3 2 1