

NOTE:

- MATERIAL SPECIFICATION:
  - HOUSING:HIGH TEMPERATURE RESISTANT PLASTIC,UL94 V-0.
  - TERMINAL:COPPER ALLOY
  - MID PLATE: STAINLESS STEEL
  - OUT SHELL: STAINLESS STEEL
  - INNER SHELL: STAINLESS STEEL
  - GLUE:EPOXY,BLACK
  - OUT GASKET:UV GLUE,RED
- PLATING SPECIFICATION:
  - CONTACTS:
    - Ni 50u" MIN. UNDER PLATED OVER ALL.
    - Au PLATED ON THE FUNCTIONAL AREA OF CONTACT.
    - CONTACT FUNCTIONAL AREA PLATED : Au 3u"
    - CONTACT SOLDER AREA PLATED : Au G/F"
  - OUT SHELL&INNER SHELL:
    - Ni 30u" MIN. UNDER PLATED OVER ALL.
  - MID PLATE:
    - CLEAR ONLY
- MECHANICAL PERFORMANCE,
  - INSERTION FORCE: 0.5~2.0kgf.
  - REMOVAL FORCE: 0.8kgf~2.0kgf.
  - DURABILITY: 10000 CYCLES.
- ELECTRICAL PERFORMANCE,
  - VOLTAGE RATING:5 V DC/AC (RMS. max)  
CURRENT RATING:5 AMPS. FOR TOTAL VBUS/GND PINS;  
1.25AMPS FOR CC PIN,0.25 AMPS. FOR ALL OTHER CONTACT.
  - LLCR:
    - VBUS & GND PINS AND OTHER PINS: 40mΩ/PIN MAX.
    - LLCR MAX. CHANGE OF ALL PINS: 10mΩ.
  - INSULATION RESISTANCE: 100MΩ MIN
  - DIELECTRIC WITHSTAND VOLTAGE,AC 100V FOR 1 MINUTE.
- ENVIRONMENTAL PERFORMANCE:
  - OPERATING TEMPERATURE: -40°C~+85°C.
- IR REFLOW:
  - THE PEAK TEMPERATURE ON THE BOARD SHALL BE MAINTAINED FOR 10 SECONDS AT 260°C.
- WATERPROOF:IPX7

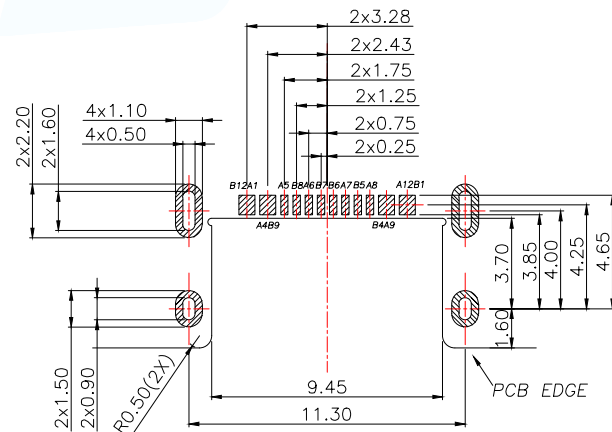

MANUFACTURE DWG		东莞市讯普电子科技有限公司 DongGuan XunPu Electronics Co.,Ltd	
UNLESS OTHERWISE SPECIFIED TOLERANCES			TITLE:USB CF 16P SMT TYPE MID-MOUNT CH=0
			PAR TYPEC-700-ARP16X7
DECIMALS:	ANGLES:		DWN
.X:±0.30	X.:±10°		CHKD
.XX:±0.20	.X':±8°	APVD	SCALE1:1 UNIT:MM
.XXX:±0.10		CUSTOMER COPY	SIZE:A4 SHEET:1F1 REV:A

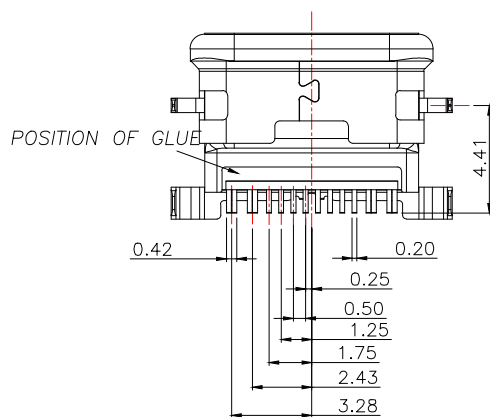
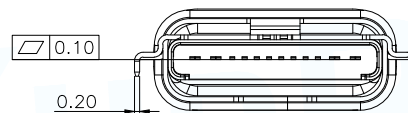
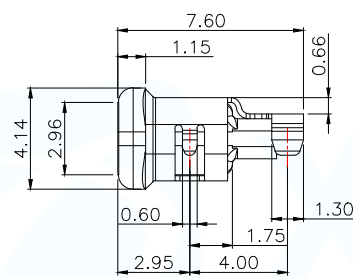
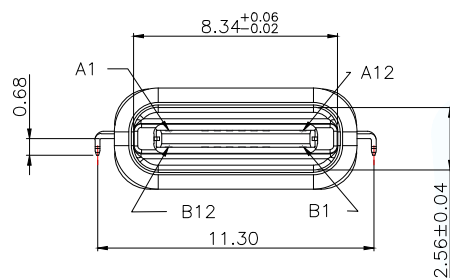
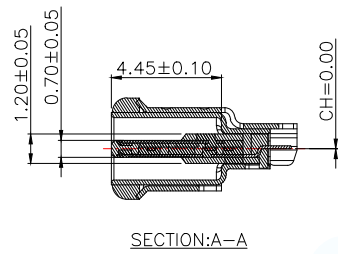

SECTION:A-A

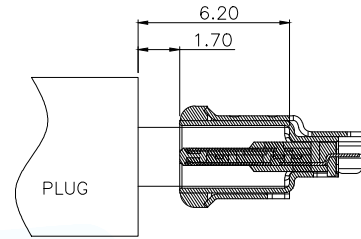

AFTER MATING

RECOMMENDED OPENING DIMENSIONS OF CASE MATING AREA WITH SEALING RING

USB TYPE-C PIN ASSIGNMENTS

PIN NUMBER	SIGNAL NAME	PIN NUMBER	SIGNAL NAME
A1	GND	B12	GND
/	/	/	/
A4	Vbus	B9	Vbus
A5	CC1	B8	SBU2
A6	Dp1	B7	Dn2
A7	Dn1	B6	Dp2
A8	SBU1	B5	CC2
A9	Vbus	B4	Vbus
/	/	/	/
/	/	/	/
A12	GND	B1	GND

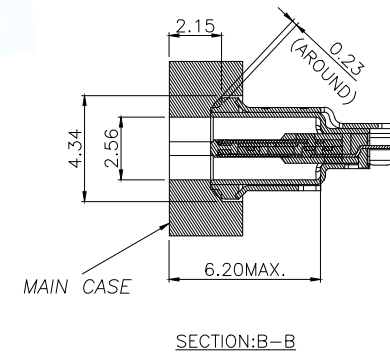
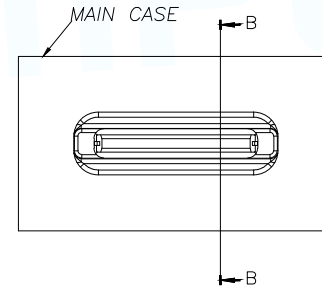

SECTION:B-B

MANUFACTURE DWG		 东莞市讯普电子科技有限公司 DongGuan XunPu Electronics Co.,Ltd	
UNLESS OTHERWISE SPECIFIED TOLERANCES		TITLE:USB CF 16P SMT TYPE MID-MOUNT CH=0	
		PAR	TYPEC-700-ARP16X7
		DWN	
		CHKD	
		APVD	
		SCALE:1:1	UNIT:MM
		SIZE:A4	SHEET:1F1
			REV:A



CUSTOMER COPY

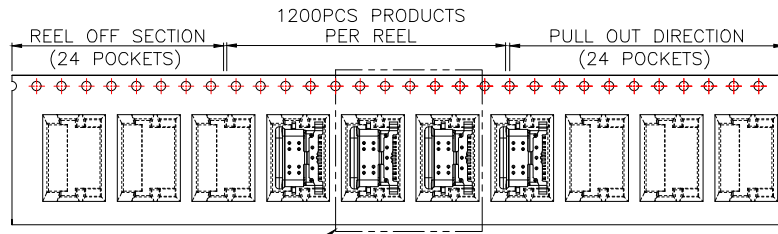

SEE DETAIL X

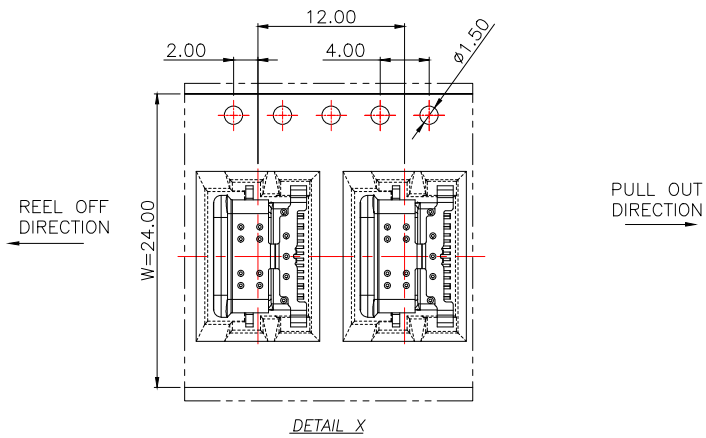
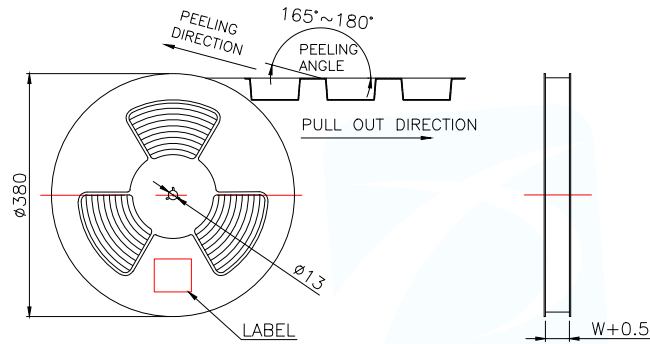

DETAIL X

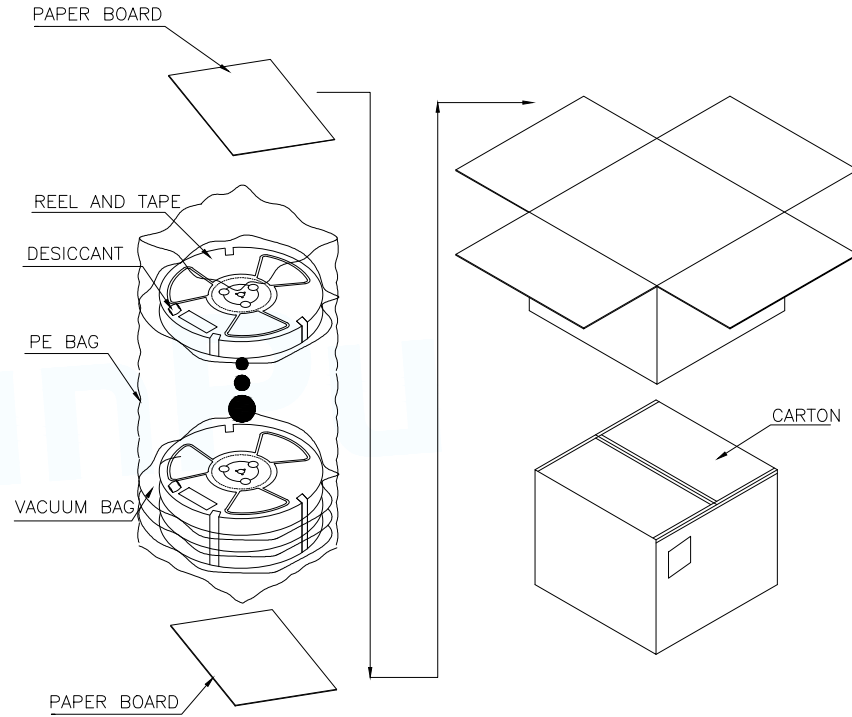

	REEL/TRAY	CARTON
CONNECTOR (PCS)	1200	12000

MANUFACTURE DWG		 东莞市讯普电子科技有限公司 DongGuan XunPu Electronics Co.,Ltd	
UNLESS OTHERWISE SPECIFIED TOLERANCES		TITLE:USB CF 16P SMT TYPE MID-MOUNT CH=0	
		PAR	TYPEC-700-ARP16X7
DECIMALS:		DWN	
ANGLES:		CHKD	
.X:±0.30	X':±10'	APVD	
.XX:±0.20	.X':±8'	SCALE 1:1	UNIT:MM
.XXX:±0.10		SIZE:A4	SHEET:1F1
CUSTOMER COPY			REV:A

