

With the English version following
the Chinese version

描述

十六端口超高频射频模块 SIMX400，是芯联创展技术团队基于 IMPINJ 新一代射频芯片 E710/E510/310 研发的高性价比超高频 RFID 读写模块。

输出功率从 5dBm 到 33dBm (30dBm) 可设置，标签读取距离大于 12 米（取决于天线增益和标签尺寸），且具有卓越的多标签盘存性能。

SIMX400 模块稳定可靠，采用先进的多标签识别算法，标签在移动或者静止状态下都能快速识别。

优越的抗干扰设计以及载波抵消功能，在各种环境下都能稳定工作。

多种配置模式，可广泛用于仓储，物流，产线，巡查等各种应用场合。

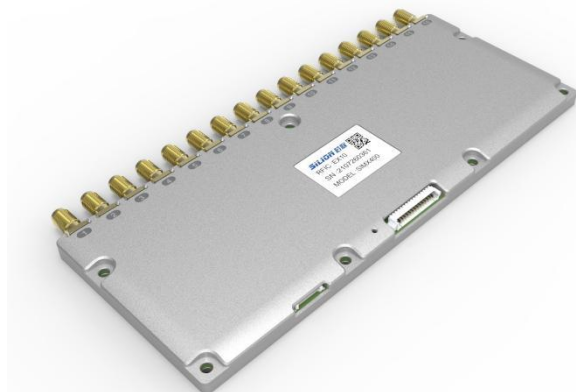

应用

- 档案柜
- 工具柜

特点

- ARMv7-M 架构 32bit Cortex-M4 CPU，集成 FPU、MPU，DSP，最高工作主频 200MHz，512KByte 的 Flash
- 支持 UHF EPC Class1 Gen2/ISO 18000-6C
- 提供 Windows，Linux，Android SDK，以及基于 C，C#/.NET，JAVA 的 API
- 支持温度标签盘存，输出参数可包含标签返回信号的 RSSI，相位值
- 十六通道天线轮询输出
- 国内版本最大 33dBm 功率输出
- 认证版本最大 30dBm 功率输出
- 优异的防冲突算法，低灵敏度，盘存标签最快速度大于 1000tag/s
- 多种盘存模式适应大多数应用
- 可设置 UART 串口通信波特率 9600bp~921600bps
- 两输入两输出 GPIO
- 板载温度实时监测，配合铝壳散热，确保模块长时间稳定工作。
- 尺寸：181.5mm*80.3mm*8mm

- 天线连接状态监测，实时保护接收机。
- 获得 SRRC, CE, FCC 等认证
- 符合 ROHS 要求

型号	灵敏度 @PER 10%	读标签速度 @96 bit EPC)
SIM7400	-84dbm	>1000
SIM5400	-78dbm	>600
SIM3400	-71dbm	>350

绝对最大额定值

参数	符号	最小值	典型值	最大值	单位
输入电压	VCC	-0.3		6	V
使能电压	VEN	-0.3		6	V
复位(NRST) GPI (IN1 IN2)输入低电压	VIL			0.6	V
复位(NRST) GPI (IN1 IN2)输入高电压	VIH	2.7			V
GPO (OUT1 OUT2)输出电流	IOH			15	mA
模块输出电流	AVCC			20	mA
ESD 保护电压 ¹	VESD	-6		6	kV
天线口 (ANT) 驻波比 ²	VSWR			8	/
工作温度 ³	TC	-30		75	°C
存储温度	TS	-55		100	°C



ESD 注意事项

在搬运、包装和测试设备时必须遵守适当的预防措施。

1. 天线端口测试条件 IEC61000-4-2 等级 1，接触放电；其他接口为 HBM 模型，接触放电。
2. 防止功放芯片损坏的最大允许驻波比，为了保证性能，建议天线驻波比小于 2.0。
3. 环境温度，温度最大限值与模块散热条件有关。

通用工作条件

参数	符号	最小值	典型值	最大值	单位
输入电压	VCC	4.5		5.5	V
失能电压	VEN			0.4	V
使能电压		1.5			V
复位(NRST) GPI (IN1 IN2) 输入低电压	VIL			0.3	V
复位(NRST) GPI (IN1 IN2) 输入高电压	VIH	3			V
GPO (OUT1 OUT2) 输出电流	IOH		10		mA
模块输出电流	AVCC		10		mA
天线口 (ANT) 驻波比 ²	VSWR			2.5	/
工作湿度 (未冷凝)	RH	5		95	%
工作温度	TC	-25		65	°C
存储温度	TS	-40		85	°C

通用电气参数

参数		条件	最小值	典型值	最大值	单位	
频率	频率范围 ¹		860		960	MHz	
	频率步进值 ²			250/500		KHz	
	频率误差	@25°C	-10		10	ppm	
输出	输出功率		5		33	dBm	
	功率步进			1		dB	
	输出功率精度	5dBm~33dBm	-1		1	dB	
	输出功率平坦度	5dBm~33dBm	-1		1	dB	
	邻道泄露比*	第 1 邻道			-45		dB
		第 2 邻道			-65		dB
	20dB 占用带宽*	RF_MODE 7			110		KHz
		RF_MODE 11			215		KHz
	发射频谱模板* ³	裕量	2			dB	
	杂散发射（传导） ⁴	二次谐波			-55		dBm
三次谐波				-38		dBm	
测量	模块温度精度	-25°C~115°C ⁵	-4		4	°C	
	标签 RSSI 测试精度	@-60dBm	-3		3	dB	
	标签相位测试精度	@-60dBm	-5		5	degrees	
	负载回波损耗测试精度	RL>18dB 接衰减器	-4		4	dB	
UART	默认波特率	数据格式：8N1		115200		bps	
	可设置波特率		9600		921600	bps	
功耗	掉电模式			0.00025		W	
	低功耗待机模式			0.1		W	
	普通待机模式			1.05		W	
	工作模式 ⁶	北美、欧洲 @30dBm			11.5		W
中国@33dBm				15.5		W	

1. 频率区域选择频段，不能同时支持多个频率区域。
 2. 可根据频率区域配置所需频率步进。
 3. 参考《ETSI EN 302 208》 4.3.5 Transmitter spectrum masks。
 4. 全频段条件下测试。
 5. 当温度超过 90°C 时，模块强制停止模块盘存，需要手动重新发送命令启动盘存。
 6. 模块工作功耗会因负载天线匹配情况而有所变化。
- 标注 * 表示测试时采用盘存模式 为 RF_MODE 7, 频谱仪设置 MAXHOLD。

空口模式参数与性能

RF_MODE ID	Forward Link Modulation	Tari (us)	BLF (KHz)	Reverse Link Modulation	Receive Sensitivity Minimum ¹ (dBm)			Read Rate ² (tags/s)
					E710	E510	E310	
11	PR-ASK	7.5	640	FMO	-64.1	N/A	N/A	>900
1	PR-ASK	7.5	640	Miller M=2	-70.4	-65.4	N/A	>650
15	PR-ASK	7.5	640	Miller M=4	-76.2	-70.2	N/A	>450
12	PR-ASK	15	320	Miller M=2	-76.6	-71.4	-63	>350
3	PR-ASK	20	320	Miller M=2	-76.1	-71.4	-63	>300
5	PR-ASK	20	320	Miller M=4	-81.5	-75.5	-66.7	>200
7	PR-ASK	20	250	Miller M=4	-81.4	-76	-68	>150
13	PR-ASK	20	160	Miller M=8	-87.4	-81	-73.4	>70

1. 测试仪器 CISC XPLORER 200, PER 10%, 输出功率 30dBm, 天线端口回波小于-20dB
2. 测试天线增益 12dBi, 4000 个标签
3. N/A 表示不支持此模式

从上表可以看出，SIMX400 提供了多达 8 种配置方式，列出了衡量读写器模块最重要的两项指标：灵敏度和读多标签速度。灵敏度与多标签速度之间需要作出权衡，因为灵敏度更好的模式下读标签速率低。在读得更好与读得更多之间，需要根据应用需求选择合适的模式。另一项需要注意的是当多阅读器同时工作时，会存在干扰。更小的 TARI 虽然加快了与标签的通信连接，但会增加发射信道的带宽，更容易干扰其他读写器。更高的标签的反向散射链路频率 (BLF) 提高了标签反向传输信号的速度，标签返回信号会落在相邻信道内，当有其他读写器正好工作在这个信道内时，读写器很可能无法解调出标签的返回信号。

盘存模式参数

针对不同的应用场景，SIMX400 提供了多种工作模式。除了控温多标签盘存模式，其他都由读写器模

块自动完成，不仅节省了主机与读写器模块的命令交互时间，优秀的处理算法也大大增强了产品的应用适配性。

应用场景	工作模式	描述
少量标签 远距离盘存	普通模式	推荐 RF_MODE 13, session0, >50tag/s
	快速模式	推荐 RF_MODE 13, session0/1, 标志状态 A-B, >70tag/s
多标签盘存	EX10 快速模式	RF_MODE 自动调整, 推荐采用高波特率, 读全标签速度快, SIM7400: >700tag/s ; SIM5400: >500tag/s ; SIM3400: >300tag/s
控温多标签盘存	E7 控温模式	RF_MODE 自动调整, 当新增标签小于指定个数时, 自动调整工作占空比, 当新增标签超过指定个数时, 恢复全速模式, SIM7400: >700tag/s ; SIM5400: >500tag/s ; SIM3400: >300tag/s
高读速率 盘存	快速模式	推荐模式 RF_MODE 103(E710)、RF_MODE 120(E510)、RF_MODE 12 (E310) , session0, 标志状态 A-B, 静态 Q 值, SIM7400: >700tag/s ; SIM5400: >500tag/s ; SIM3400: >300tag/s

引脚配置及功能



引脚编号	引脚名称	类型	描述
1	GND	电源	接地
2	GND	电源	接地
3	VCC	电源	供电电压, 4.75V-5.25V 输入
4	VCC	电源	供电电压, 4.75V-5.25V 输入
5	OUT1	数字 I/O	通用 I/O 口输出, 推挽输出
6	OUT2	数字 I/O	通用 I/O 口输出, 推挽输出
7	IN1	数字 I/O	通用 I/O 口输入
8	IN2	数字 I/O	通用 I/O 口输入
9	RXD	数字输入	模块 UART 输入, 3.3V 电平
10	TXD	数字输出	模块 UART 输出, 3.3V 电平
11	NC	空	请悬空, 不要接地
12	NC	空	请悬空, 不要接地
13	NC	空	请悬空, 不要接地
14	EN	数字输入	模块使能脚, 接低电平或悬空时模块使能, 接高电平时模块掉电
15	NRST	数字输入	模块复位脚, 接低电平时模块复位, 不使用时可悬空
	ANT1-ANT16	射频	射频天线端口 (50 Ω)

应用说明

● 上电启动与 I/O 接口

模块上电后，需要花费 100ms 进行初始化，在这段时间内不要拉低复位引脚，读写器模块也不会响应接收到的命令。

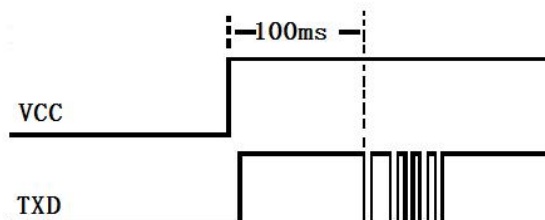

上电启动时间

NRST 上电复位解除时间小于 3ms，模块上电后，NRST 电平拉低会使内部模块的 MCU 重新启动。模块内 NRST 已接 100K 上拉电阻。如果模块已上电，触发复位的低电平保持时间需大于 2ms。当复位发生时，实际等待复位时间需大于 110ms。

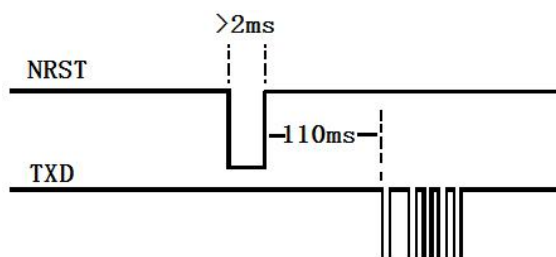

复位等待时间

通过发送获取 GPIO 命令与响应的的时间差测得响应时间。OUT1，OUT2 设置命令动作时间大于 78us（不含命令时间）。IN1，IN2 设置命令动作时间大于 88us（不含命令时间）。

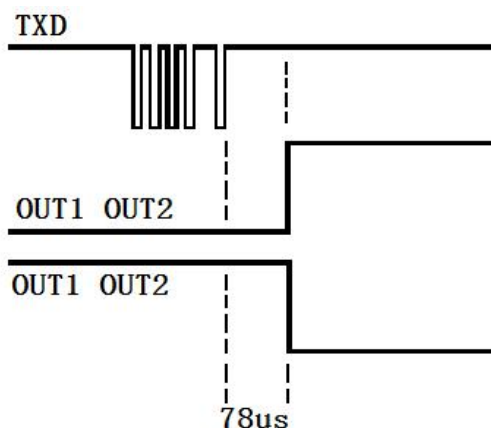

OUT1，OUT2 动作时间



IN1, IN2 动作时间

EN 脚内置 200K 下拉电阻，EN 脚接低电平或悬空时模块上电，EN 脚接高电平时模块掉电。

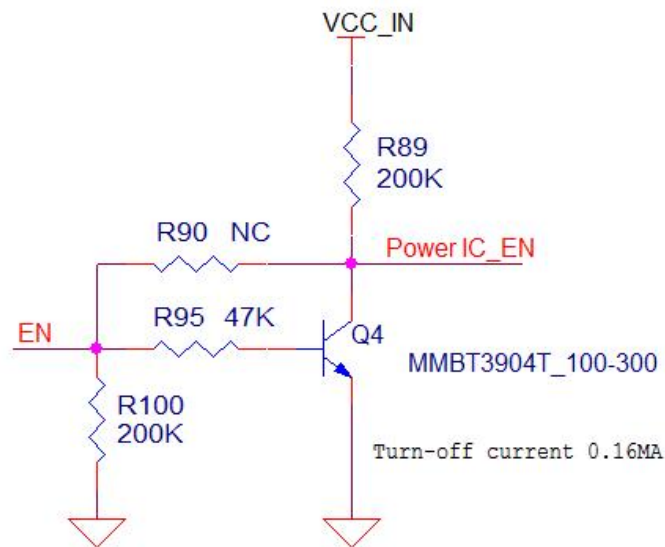

● 输入电源

由于模块工作电流较大，建议使用 5V4A 的稳压电源，以保证模块能正常稳定工作。

VCC 电源输入建议使用一个 22~100uF 的钽电容, 如果尺寸限制, 也可以改为小尺寸的陶瓷电容, 并且至少并联一个 0.1uF 与一个 100pF 陶瓷电容。盘存标签时, 模块内部功放会频繁开启和关闭, 这会导致模块输入端电源电压也随着产生波动。增加大容量电容可以减小这些电压的波动幅度, 滤除掉低频信号的干扰, 同时也会引起瞬间流过大, 根据模块供电电路的驱动能力, 选择合适的大容量退耦电容。而 0.1uF 和 100pF 电容用于滤除高频段的电源纹波, 因为高频段的干扰信号, 特别是工作频段的干扰信号进入到模块, 将会使模块的读标签性能下降, 此外陶瓷电容的加入也能防止模块工作时产生的高频信号通过电源通路, 干扰到其他电路系统。

由于模块工作电流较大, 连接模块的排线要足够粗, 否则连接线两端会产生过大的压差, 将使模块无法正常工作; 过细的连接线也更容易产生辐射的干扰信号。

如果电源输入是 DC-DC 转换电路，最好选择开关频率超过 1.5MHz 的电源转换芯片，避免对标签返回的微弱信号产生干扰。

● 通讯串口

读写器模块采用 3.3V UART 串口进行数据通信，数据格式配置为 1 位起始位，8 位数据，1 位停止位，无校验位（8N1）。

串口的波特率需要满足模块上传标签数据的传输速率要求，盘存较多标签时，推荐波特率如下表所示：

RF_MODE ID	Forward Link Modulation	BLF (KHz)	Reverse Link Modulation	Baud Rate Select
103	DSB-ASK	640	FMO	921600
11	PR-ASK	640	FMO	921600
120	DSB-ASK	640	Miller M=2	>460800
1	PR-ASK	640	Miller M=2	>460800
345	PR-ASK	640	Miller M=4	>230400
15	PR-ASK	640	Miller M=4	>230400
12	PR-ASK	320	Miller M=2	>230400
3	PR-ASK	320	Miller M=2	>230400
5	PR-ASK	320	Miller M=4	>115200
7	PR-ASK	250	Miller M=4	>57600
13	PR-ASK	160	Miller M=8	>57600

● 天线端口

十六天线轮询工作，天线端口之间拥有 50dB 的高隔离度，可以很好的在应用在防止信号泄露。

当模块与天线不匹配时，从天线反射回读写器模块信号过大，这会使接收灵敏度恶化，建议天线驻波比小于 1.5。当使用 E710 芯片的模块应用在需要快速读取大量标签的应用场合时，如果天线驻波较大导致接收灵敏度恶化后，会极大地增加读全标签的时间；对于距离近标签少

的应用环境，选择使用 E510 或者 E310 的模块更加合适。

由于模块内的功放芯片与天线之间并未使用 RF 隔离器或者 RF 环形器进行隔离，当功放芯片与天线不匹配时，功放芯片输出的线性度与转换效率会发生变化。前者会使发射性能发生变化，比如功率输出减小，辐射杂散与频谱模板不符合当地无线电法规要求；后者则会使模块的功耗增加，工作温度更高，使用寿命减小，最差的情况下，功放芯片工作在匹配的不稳定区域产生自激，这种情况下，功放芯片很容易损坏。为保证模块工作的性能与稳定，建议将天线安装在应用环境中后，使用测试软件检测一下连接天线后的驻波比，天线驻波比要尽量小于 1.5。

● 散热说明

SIMx100 模块最大功率快速模式工作时发热量大，自带铝合金外壳满足不了散热要求，需要将模块固定在更大的金属散热片上。为保证导热效果需要在模块与散热片接触位置使用导热硅胶或硅脂。为了保护模块，当模块的检测温度达到 90℃时，会自动停止读写器模块盘存标签，需要再次盘存标签时，要重新发送盘存命令。

● 参考电路

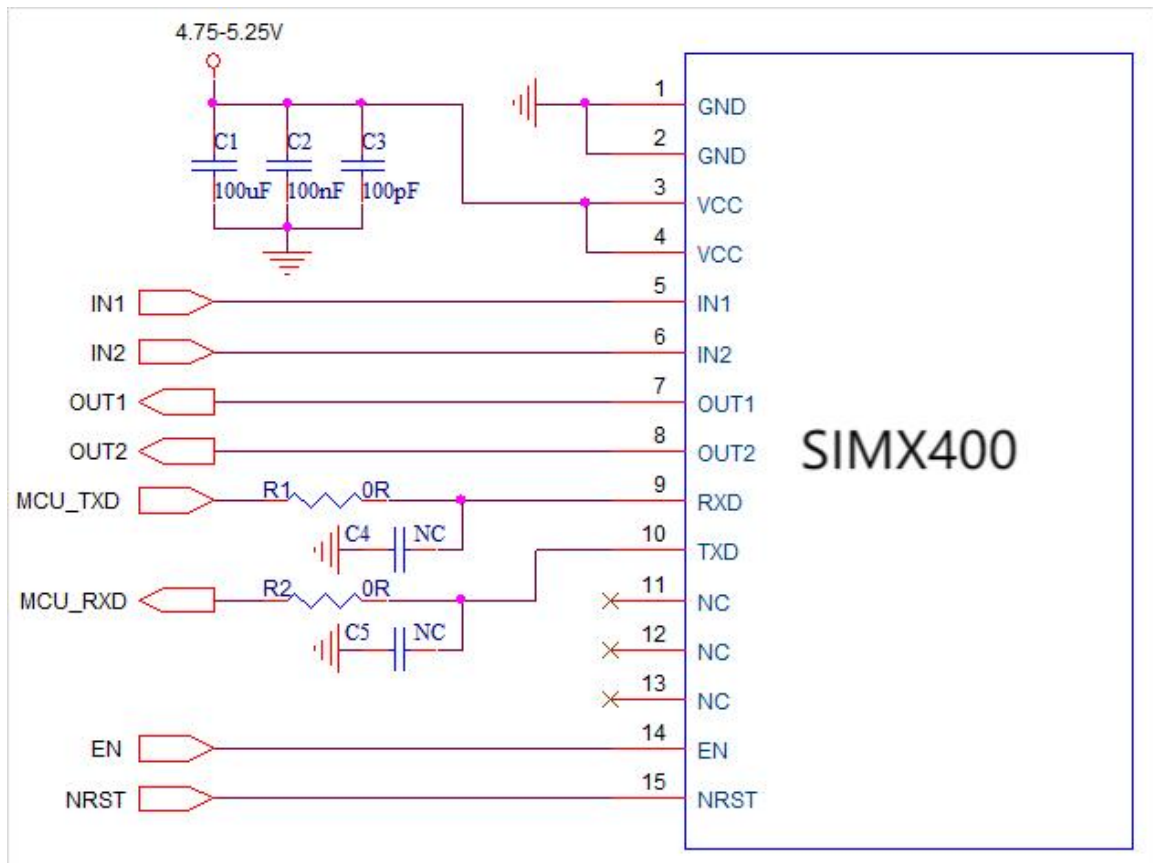

简化版参考电路

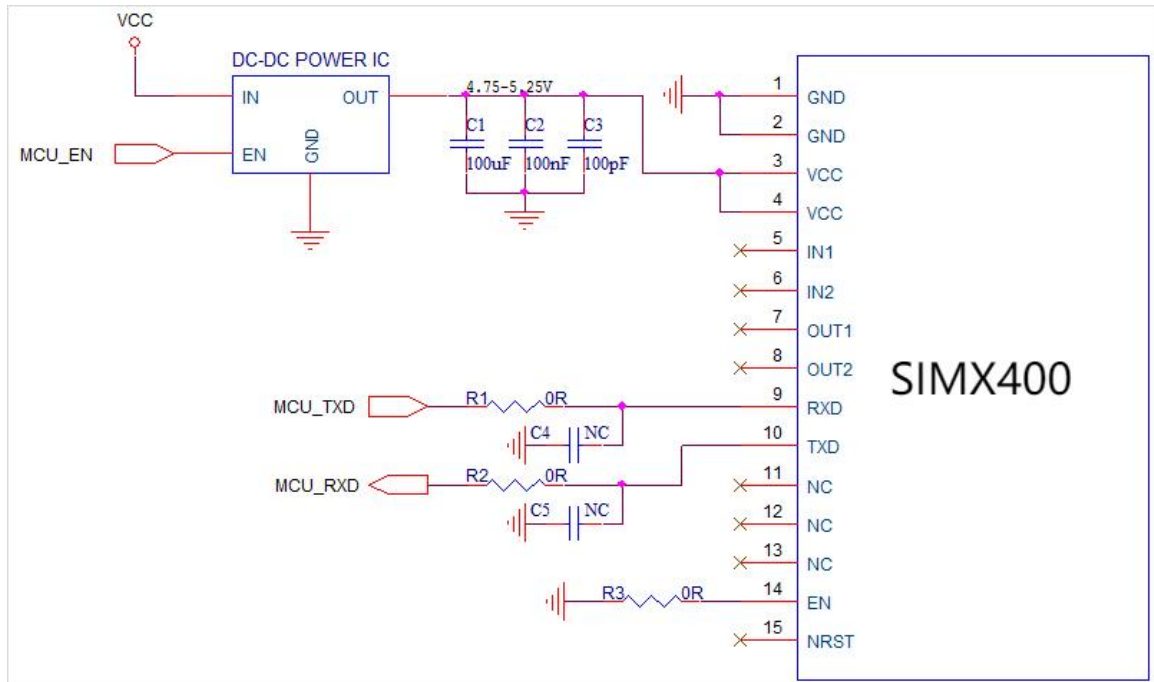

● 标记说明



— SN 二维码

读写器芯片型号: — RFIC: EX10
E710, E510, E310

SN: YYMMDDXXXX

— SN 码:
YYMMDD:年 月 日
XXXX:模块生产编号

模块型号: — MODEL: SIMX400
SIM7400
SIM5400
SIM3400

尺寸信息

● 尺寸

产品尺寸：181.5mm*80.3mm*8mm

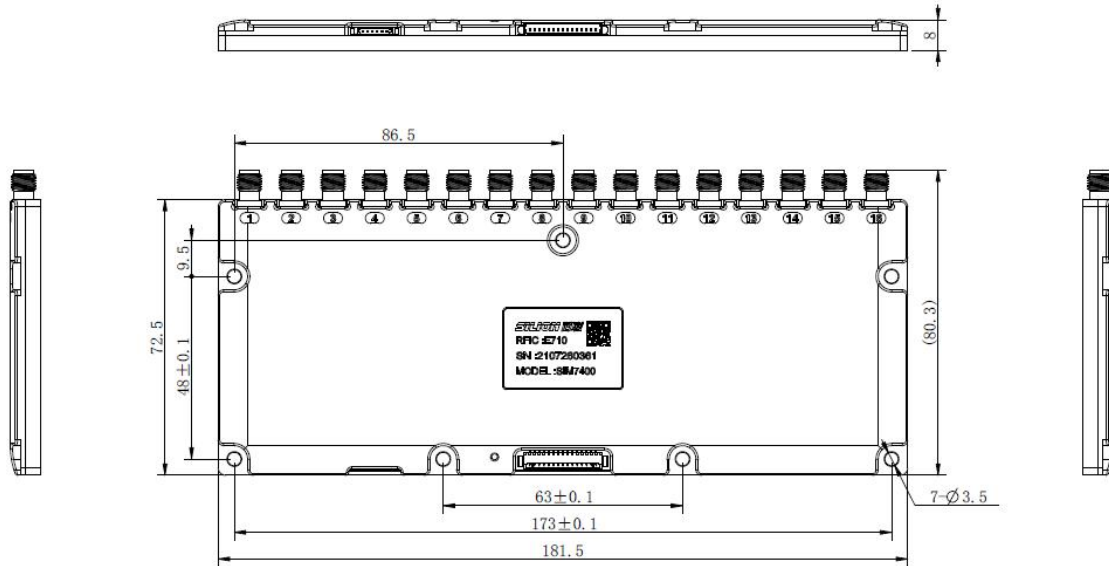

● 外观示意图

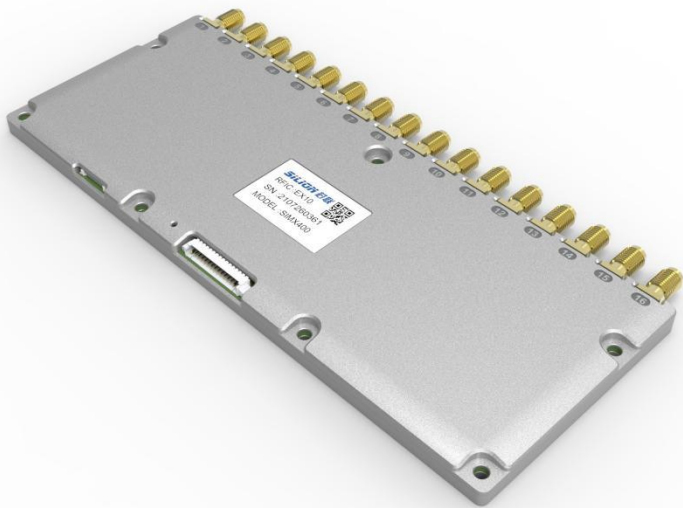

订购信息

产品型号	发射功率 (dBm)	支持频段	描述
SIM7400-0000	33	920MHz~925 MHz	SRRC
SIM7400-0100	30	902MHz~928 MHz	FCC
SIM7400-0300	30	865MHz~868 MHz	ETSI
SIM5400-0000	33	920MHz~925 MHz	SRRC
SIM5400-0100	30	902MHz~928 MHz	FCC
SIM5400-0300	30	865MHz~868 MHz	ETSI
SIM3400-0000	33	920MHz~925 MHz	SRRC
SIM3400-0100	30	902MHz~928 MHz	FCC
SIM3400-0300	30	865MHz~868 MHz	ETSI

订购前请与销售联系确认产品参数，可支持其他区域频段。

版本信息

版本	日期	修订内容
V1.0	2023/6/6	首版编辑
.....		

联系方式

如果您有产品需求或者在产品使用中有任何疑问，请随时与我们联系，我们将竭诚为您服务。

北京公司总部

地 址：北京市昌平区龙域北街3号金域国际中心A座5层

电 话：010-62153840，62153842，62153540

传 真：010-62153540 转 8008

网 址：www.silion.com.cn

电子邮件：sales@silion.com.cn

芯联创展华南区分公司

地址：深圳市南山区珠光路 52 号珠光创新科技园 1 栋 3 层

电 话：0755-26611567

传 真：0755-26617878

芯联创展华东区办事处

地 址：上海市嘉定区云谷路 599 弄 6 号楼 TEEC 上海中心大厦 311 室

电 话：18916488006

联 系 人：周经理

Overview

The UHF 16-port RFID module SIMX400 with high-performance, designed by SILION R&D team. It based on IMPINJ New Generation RF chip E710/E510/E310.

Output power can be set from 5dBm to 33dBm (30dBm). Tag reading distance is more than 12m (depending on antenna gain and tag size), And has excellent multi-label inventory performance.

SIMX400 module has stable and reliable performance, it adopts advanced multi-tag recognition algorithm. Tags can be quickly identified whether moving or stationary.

SIMX400 has superior anti-interference design and carrier cancellation function, can work stably in various environments.

SIMX400 has a variety of configuration modes, can be widely used in various applications such as warehousing, logistics, production lines, and patrol.

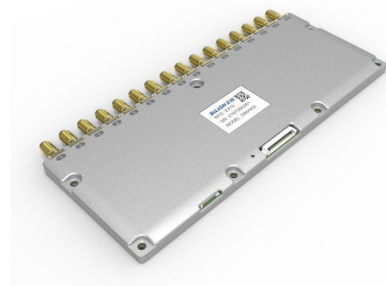

Application

- Filing cabinet
- Tool cabinet

Features

- ARMv7-M architecture 32bit Cortex-M4 CPU, integrated FPU, MPU, DSP, the highest work main frequency is 200MHz, 512KByte Flash
- Support UHF EPC Class1 Gen2/ISO 18000-6C
- Provide Windows, Linux and Android SDK, and API based on C, C#/.NET, JAVA
- Support inventory of temperature tags, the output parameters include the RSSI and phase value

of the tag return signal

- 16-port antenna polling output, the shortest polling time is less than 25mS
- Domestic version with max power output of 33dBm
- Certified version with max power output of 30dBm
- SIMX400 has excellent anti-collision algorithm and high sensitivity. The fastest speed of inventory tags is greater than 1000tag/s
- Multiple inventory modes suitable for most applications
- The UART serial communication baud rate can be set from 9600bp to 921600bps
- 2 input 2 output GPIO
- Onboard temperature real-time monitoring, combined with aluminum shell heat dissipation, ensures that the module can work stably for long time.
- Size: 181.5mm*80.3mm*8mm
- Antenna connection status monitoring, real-time protection of the receiver.
- Obtained SRRC, CE, FCC and other certifications
- Comply with ROHS requirements

Model	Sensitivity @PER 10%	The speed of inventory tag @96 bit EPC)
SIM7300	-86dbm	>1000
SIM5300	-79dbm	>600
SIM3300	-72dbm	>350

Absolute Max Ratings Value

Parameter	Sign	Mini	Typical	Max	Unit
Input voltage	VCC	-0.3		6	V
Enable voltage	VEN	-0.3		6	V
Reset (NRST) GPI(IN1 IN2) input low voltage	VIL			0.6	V
Reset (NRST) GPI(IN1 IN2) input high voltage	VIH	2.7			V
GPO (OUT1 OUT2) output current	IOH			15	mA
Module output current	AVCC			20	mA
ESD protection voltage ¹	VESD	-6		6	kV
Antenna port (ANT) standing wave ratio ²	VSWR			8	/
Operating temperature ³	TC	-30		75	°C
Storage temperature	TS	-55		100	°C



ESD Precautions

Proper precautions must be followed when transporting, packaging and testing the equipment.

1. Antenna port test conditions IEC61000-4-2 level 1, contact discharge; other interfaces are HBM model, contact discharge.
2. The maximum allowable standing wave ratio to prevent damage to the power amplifier chip. To ensure performance, it is recommended that the antenna standing wave ratio be less than 2.0.
3. Ambient temperature. The max temperature limit is related to the module heat dissipation conditions.

General Operating Conditions

Parameter	Sign	Mini	Typical	Max	Unit
Input voltage	VCC	4.5		5.5	V
Disabling voltage	VEN			0.4	V
Enable voltage		1.5			V
Reset (NRST) GPI(IN1 IN2) input low voltage	VIL			0.3	V
Reset (NRST) GPI(IN1 IN2) input high voltage	VIH	3			V
GPO(OUT1 OUT2) output current	IOH		10		mA
Module output current	AVCC		10		mA
Antenna port (ANT) standing wave ratio ²	VSWR			2.5	/
Operating humidity (non-condensing)	RH	5		95	%
Operating temperature	TC	-25		65	°C
Storage temperature	TS	-40		85	°C

General Electrical Parameters

Parameters		Condition	Mini	Typical	Max	Unit	
Frequency	Range ¹		860		960	MHz	
	Step value ²			250/500		KHz	
	Deviation	@25°C	-10		10	ppm	
Output	Output power		5		33	dBm	
	Power step			1		dB	
	Output power accuracy	5dBm~33dBm	-1		1	dB	
	Output power flatness	5dBm~33dBm	-1		1	dB	
	Adjacent channel leakage ratio*	1 st adjacent channel			-45		dB
		2 nd adjacent channel			-65		dB
	20dB occupied bandwidth*	RF_MODE 7			110		KHz
		RF_MODE 11			215		KHz
	Emission spectrum template* ³	margin	2			dB	
	Spurious Emissions (Conducted) ⁴	2 nd harmonic			-55		dBm
3 rd harmonic				-38		dBm	
Measure	Module temperature accuracy	-25°C~115°C ⁵	-4		4	°C	
	Tag RSSI test accuracy	@-60dBm	-3		3	dB	
	Tag PHASE test accuracy	@-60dBm	-5		5	degrees	
	Load return loss test accuracy	RL>18dB Connect the attenuator	-4		4	dB	
UART	Default baud rate	Data format:		115200		bps	
	Configurable baud rate	8N1	9600		921600	bps	
Consumption	Power down mode			0.00025		W	
	low consumption standby mode			0.1		W	
	Normal standby mode			1.05		W	

Operating mode ⁶	North America、 Europe@30dBm		11.5		W
	China@33dBm		15.5		W

1. Select the frequency band by frequency range, can't support multiple frequency areas at the same time.
 2. The required frequency step can be configured according to the frequency range.
 3. Refer to 《ETSI EN 302 208》 4.3.5 Transmitter spectrum masks。
 4. Test under full frequency range conditions.
 5. When temperature exceeds 90 °C , the module will forcefully stop inventory, then need to manually resend the command to start inventory.
 6. The operating power consumption of the module is determined based on the matching of the load antenna.
- Mark* Indicates that the inventory mode RF_MODE 7 is used during testing and the spectrum analyzer is set to MAXHOLD.

Air Interface Mode Parameters and Performance

RF_MODE ID	Forward Link Modulation	Tari (us)	BLF (KHz)	Reverse Link Modulation	Receive Sensitivity Minimum ¹ (dBm)			Read Rate ² (tags/s)
					E710	E510	E310	
11	PR-ASK	7.5	640	FMO	-64.1	N/A	N/A	>900
1	PR-ASK	7.5	640	Miller M=2	-70.4	-65.4	N/A	>650
15	PR-ASK	7.5	640	Miller M=4	-76.2	-70.2	N/A	>450
12	PR-ASK	15	320	Miller M=2	-76.6	-71.4	-63	>350
3	PR-ASK	20	320	Miller M=2	-76.1	-71.4	-63	>300
5	PR-ASK	20	320	Miller M=4	-81.5	-75.5	-66.7	>200
7	PR-ASK	20	250	Miller M=4	-81.4	-76	-68	>150
13	PR-ASK	20	160	Miller M=8	-87.4	-81	-73.4	>70

1. Test instrument CISC XPLOER 200, PER 90%, output power 30dBm, antenna port echo less than -20dB.
2. Test antenna gain 12dBi, 4000 tags.
- 3.N/A indicate this mode is not supported.

From the above table, SIMX400 provides up to 8 configuration methods, listing the two most important indicators for measuring the reader module: sensitivity and multi-tag reading speed. There is a trade-off between sensitivity and multi-tag speed. When the sensitivity is better, the reading speed rate of tags is lower. Between reading better and reading more, need to choose the appropriate mode based on customer application needs. Another thing to note is that when

multiple readers work at the same time, there will be interference. Although a smaller TARI speeds up the communication connection with the tag, it will increase the bandwidth of the emission channel, which is easier to interfere with other readers. Higher BLF of the tag will increase the speed of the tag's reverse transmission signal. The tag return signal will fall in the adjacent channel. When other readers happen to be working in this channel, the reader is likely to be unable to demodulate the return signal of the label.

Inventory Mode Parameters

For different application scenarios, SIMX400 provides multiple working modes. Except for the temperature-controlled multi-tag inventory mode, other function are automatically completed by the reader module. This not only saves the command interaction time between the host and the reader module, but the excellent processing algorithm also greatly enhances the application adaptability of the product.

Application	Operating Mode	Description
Few tags, remote inventory	Normal mode	Recommend RF_MODE 13, session0, >50tag/s
	Fast mode	Recommend RF_MODE 13, session0/1, flag status: A-B, >70tag/s
Multi-label inventory	EX10 fast mode	RF_MODE auto-adjust, recommend to use high baud rate, to read all tags quickly. SIM7300: >700tag/s; SIM5300: >500tag/s; SIM3300: >300tag/s
Temperature controlled multi-tag inventory	E7 temperature control mode	RF_MODE auto-adjustable. When the number of new tags is less than the specified number, the working duty cycle is auto-adjusted; when the number of new tags exceeds the specified number, the full speed mode is restored. SIM7300: >700tag/s; SIM5300: >500tag/s; SIM3300: >300tag/s
High read rate inventory	Fast mode	Recommended mode RF_MODE 103 (E710)、RF_MODE 120(E510)、RF_MODE 12(E310), session0, flag status: A-B, static Q value, SIM7300: >700tag/s ; SIM5300: >500tag/s ; SIM3300: >300tag/s

PIN Configuration and Function



PIN No.	PIN name	Type	Description
1	GND	Power supply	Ground
2	GND	Power supply	Ground
3	VCC	Power supply	Supply voltage, 4.75V-5.25V input
4	VCC	Power supply	Supply voltage, 4.75V-5.25V input
5	OUT1	Digital I/O	General-purpose I/O port output, push-pull output
6	OUT2	Digital I/O	General-purpose I/O port output, push-pull output
7	IN1	Digital I/O	General-purpose I/O port input
8	IN2	Digital I/O	General-purpose I/O port input
9	RXD	Digital input	Module UART input, 3.3V TTL voltage
10	TXD	Digital output	Module UART output, 3.3V TTL voltage
11	NC	null	Please hang in the air, do not connect it to GND
12	NC	null	Please hang in the air, do not connect it to GND
13	NC	Null	Please hang in the air, do not connect it to GND
14	EN	Digital input	EN module power: LOW & Disconnect (ACTIVE) HIGH (POWER DOWN)
15	NRST	Digital input	RST: LOW (ACTIVE), not use, please hang in the air
	ANT1-ANT16	RF	RF antenna port (50Ω)

Application Description

● Power-on Boot and IO Interface

After the module is powered on, it takes 100ms to initialize. Do not pull the reset pin low during this time, and the reader module will not respond to the received commands.

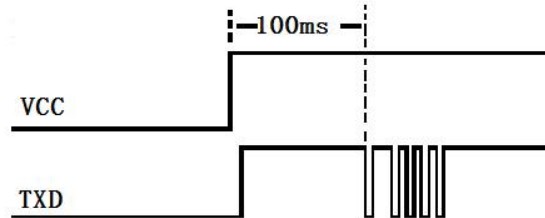

Power-on boot time

The NRST power-on reset release time is less than 3ms. After the module is powered on, pulling the NRST level low will cause the MCU of the internal module to restart. The NRST in the module has been connected to a 100K pull-up resistor. If the module is powered on, the low-level holding time that triggers the reset needs to be greater than 2ms. When reset occurs, the actual waiting time for reset needs to be greater than 110ms.

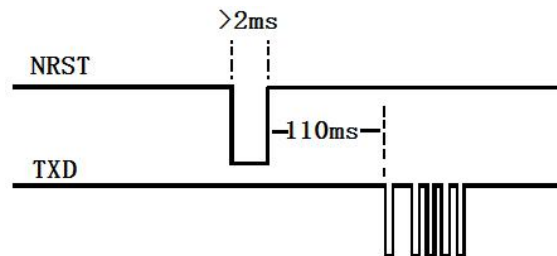

Reset waiting time

The response time is measured by the time difference between sending the GPIO command and the response. The command action time set by OUT1 and OUT2 is greater than 78us (not including command time). IN1, IN2 set command action time is greater than 88us (not including command time).

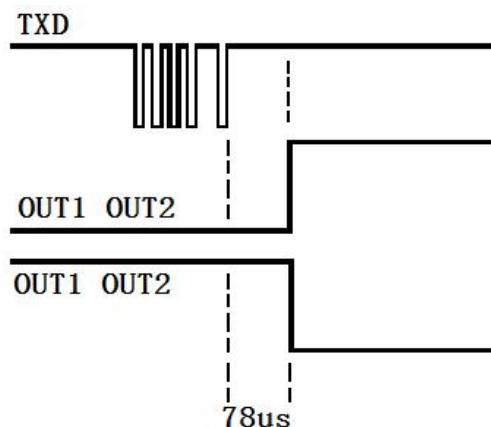

OUT1, OUT2 action time



IN1, IN2 action time

The EN pin has a built-in 200K pull-down resistor. When the EN pin is connected to low level or left floating, the module is powered on. When the EN pin is connected to high level, the module is powered down.

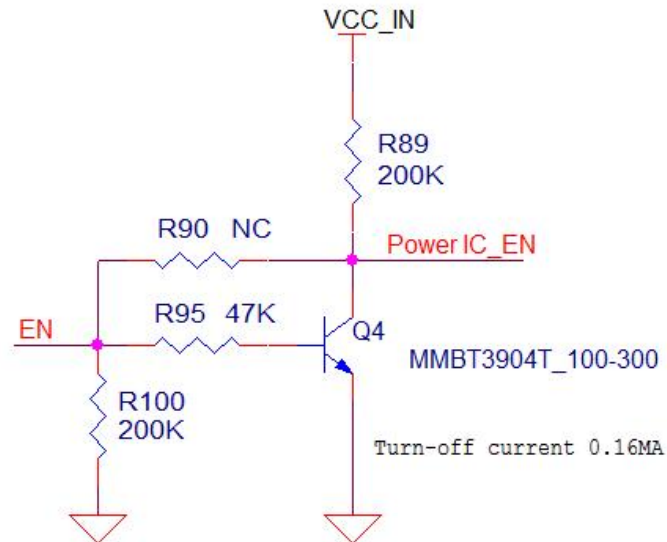

● Input Power

Due to the large operating current of the module, it is recommended to use a 5V3A regulated power supply to ensure that the module can work normally and stably.

It is recommended to use a 22-100uF tantalum capacitor for the VCC power input. If the size is limited, it can be changed to a small-sized ceramic capacitor, and at least a 0.1uF and a 100pF ceramic capacitor are connected in parallel. When inventory tag, the power magnifier inside the module will be turned on and off frequently, which will cause the power supply voltage at the input end of the module to fluctuate accordingly. Add large-capacity capacitors can reduce the fluctuation amplitude of these voltages and filter out the interference of low-frequency signals, but it will also cause large instantaneous currents. According to the driving capability of the module power supply circuit, select an appropriate large-capacity decoupling capacitor. The 0.1uF and 100pF capacitors can be used to filter out the power supply ripple in the high-frequency band. Because the interference signal in the high-frequency band, especially the interference signal in the working frequency band, will enter the module, it will degrade the module's tag reading performance. And the addition of ceramic capacitors It can also prevent high-frequency signals generated when the module is working from passing through the power path and interfering with other circuit systems.

Due to the large operating current of the module, the cable connecting the module must be

thick enough, otherwise there will be an excessive voltage difference at both ends of the connecting cable, which will make the module unable to work properly; too thin connecting cables are also more likely to produce radiated interference signals.

If the power input is a DC-DC conversion circuit, it is best to choose a power conversion chip with a switching frequency exceeding 1.5MHz to avoid interference with the weak signal returned by the tag.

● Communication Serial Port

The reader module adapts a 3.3V UART serial port for data communication. The data format is configured as 1 bit start, 8 bits data, 1 bit stop, and no check bit (8N1).

The baud rate of the serial port needs to meet the transmission rate requirements of the module for uploading tag data. When inventory large number of tags, the recommended baud rate is as shown in the following table:

RF_MODE ID	Forward Link Modulation	BLF(KHz)	Reverse Link Modulation	Baud Rate Select
103	DSB-ASK	640	FM0	921600
11	PR-ASK	640	FM0	921600
120	DSB-ASK	640	Miller M=2	>460800
1	PR-ASK	640	Miller M=2	>460800
345	PR-ASK	640	Miller M=4	>230400
15	PR-ASK	640	Miller M=4	>230400
12	PR-ASK	320	Miller M=2	>230400
3	PR-ASK	320	Miller M=2	>230400
5	PR-ASK	320	Miller M=4	>115200
7	PR-ASK	250	Miller M=4	>57600
13	PR-ASK	160	Miller M=8	>57600

● Antenna Port

16 antenna polling works. The antenna ports have a high isolation of 50dB, which can

effectively prevent signal leakage in application scenarios.

Mismatch between the module and antenna can lead to excessive signal reflection from the antenna to the reader module, causing a degradation in receiver sensitivity. It is recommended to maintain an antenna VSWR (Voltage Standing Wave Ratio) below 1.5. In applications requiring rapid reading of a large number of tags, especially when using modules based on the E710 chip, a high antenna VSWR that degrades receiver sensitivity can significantly increase the time required for reading all tags. For applications with fewer tags at closer distances, choosing modules based on the E510 or E310 may be more suitable.

Since there is no RF isolator or RF circulator used between the power amplifier chip in the module and the antenna, mismatches between the power amplifier chip and the antenna can affect linearity and conversion efficiency. The former can result in changes in transmission performance, such as reduced power output, radiation of spurious signals, and non-compliance with local radio regulations regarding spectrum masks. The latter can increase the module's power consumption, operating temperature, and reduce its lifespan. In the worst-case scenario, the power amplifier chip may operate in an unstable region due to mismatches, leading to self-excitation, which can easily damage the power amplifier chip. To ensure optimal module performance and stability, it is recommended to install the antenna in the application environment and use testing software to measure the VSWR after connecting the antenna. The VSWR should ideally be below 1.5.

● Heat Dissipation

The SIMX400 module generates significant heat during fast mode operation, and its built-in aluminum alloy casing may not provide adequate heat dissipation. To ensure effective heat conduction, it is necessary to mount the module on a larger metal heat sink. Additionally, thermal conductive silicone grease or compound should be applied at the contact points between the module and the heat sink. To protect the module from overheating, it will automatically cease tag inventory when the detected temperature reaches 90°C. In such cases, you will need to resend the inventory command to resume tag inventory.

● Reference

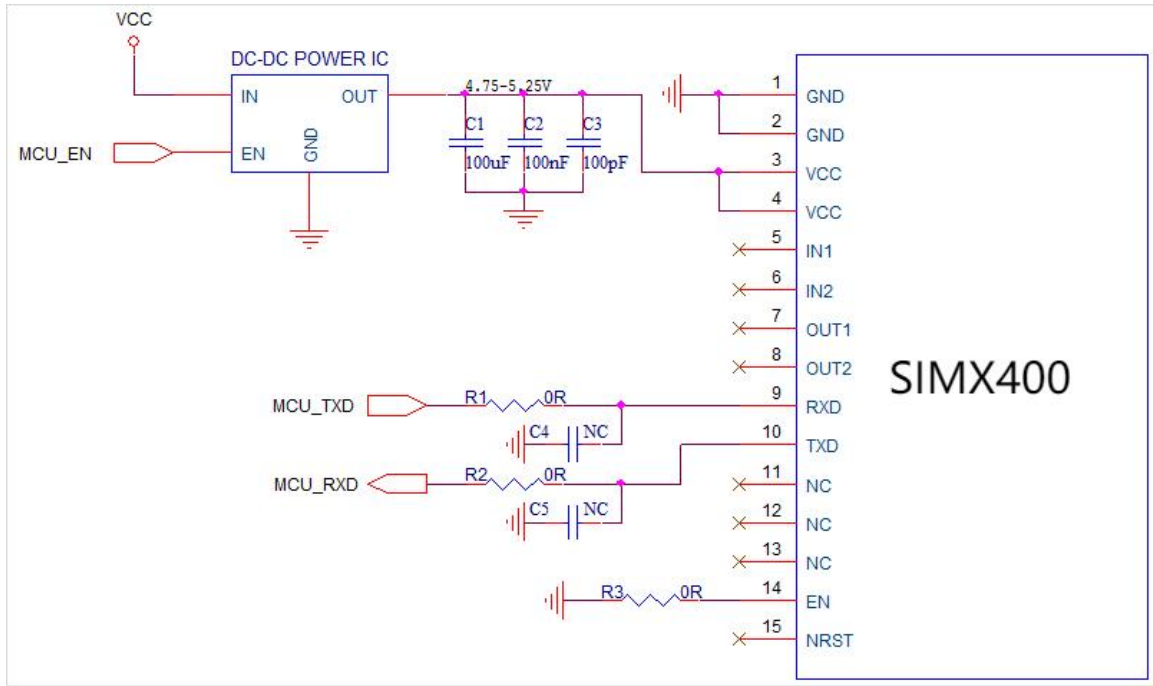

Simplified Reference Circuit

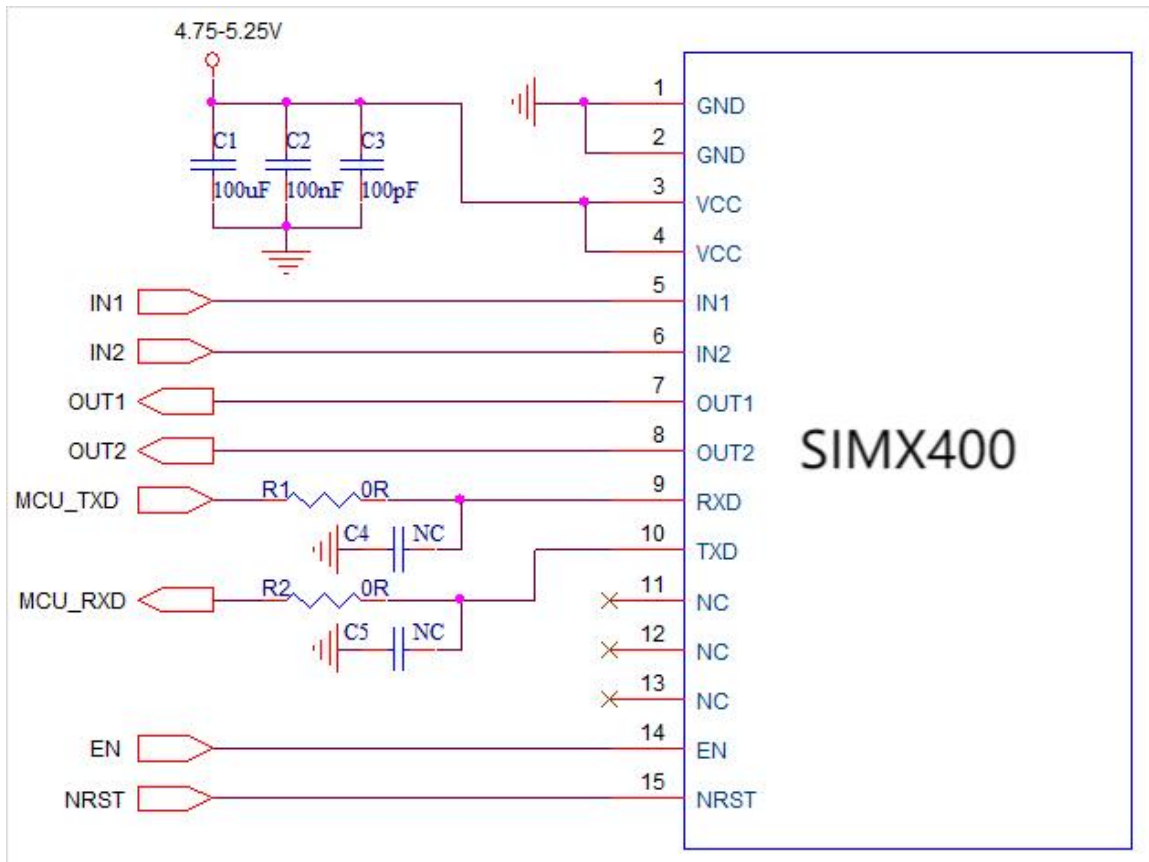

● **Label Explanation**

<p>Chipset: _____ E710, E510, E310</p> <p>Module No. : _____ SIM7200 SIM5200 SIM3200</p>	<p>SILION 芯联</p> <p>RFIC: EX10</p> <p>SN: YYMMDDXXXX</p> <p>MODEL: SIMX400</p>	 <p>. SN QR code</p>	<p>SN NO. : YYMMDD: year/month/date XXXX: module production serial</p>
--	---	--	--

Dimension

● **size**

product size: 181.5mm*80.3mm*8mm

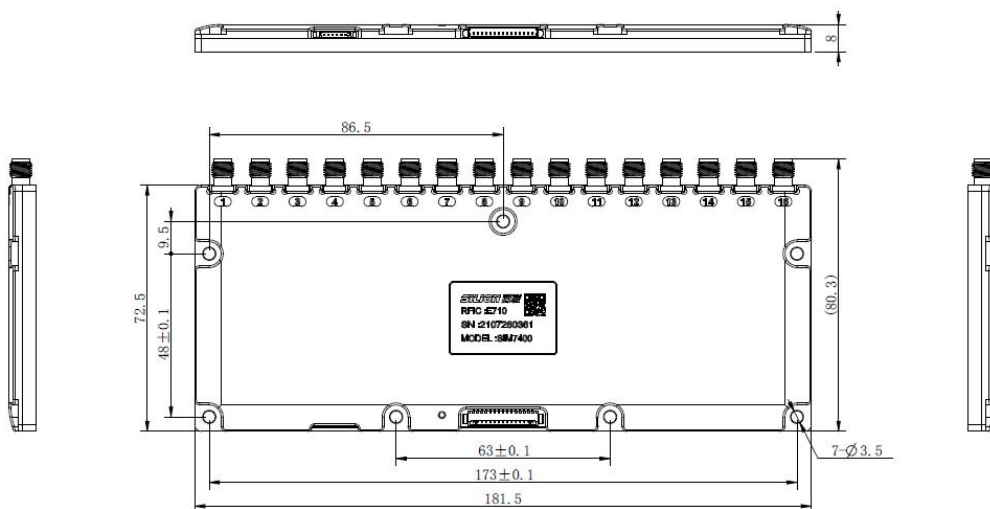

● Appearance

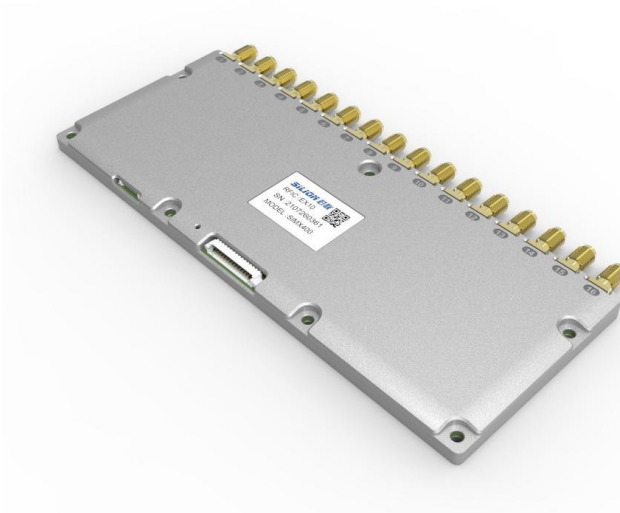

Order Information

Module No.	Output (dBm)	Frequency	Description
SIM7400-0000	33	920MHz~925 MHz	SRRC
SIM7400-0100	30	902MHz~928 MHz	FCC
SIM7400-0300	30	865MHz~868 MHz	ETSI
SIM5400-0000	33	920MHz~925 MHz	SRRC
SIM5400-0100	30	902MHz~928 MHz	FCC
SIM5400-0300	30	865MHz~868 MHz	ETSI
SIM3400-0000	33	920MHz~925 MHz	SRRC
SIM3400-0100	30	902MHz~928 MHz	FCC
SIM3400-0300	30	865MHz~868 MHz	ETSI

Please contact our sales team to confirm product specifications before placing an order. We can support other regional frequency bands as well.

Version

Version	Date	Modify content
V1.0	2023/6/6	First edition

.....		
-------	--	--

Contact

If you have any product requirements or any questions about using our products, please feel free to contact us at any time. We are here to serve you wholeheartedly.

Main Office in Beijing

Location: 5th Floor, Block A, Golden International Center, No. 3 Longyu
North Street, Changping District, Beijing, China.

Mobile: 010-62153840, 62153842, 62153540

Fax: 010-62153540 to 8008

Website: www.silion.com.cn

Email: sales@silion.com.cn

SILION Shenzhen Branch Office

Location: 3rd Floor, Building 1, Zhuguang Innovation Technology Park, No.
52 Zhuguang Road, Nanshan District, Shenzhen, China

Mobile: 0755-26611567

Fax: 0755-26617878

SILION Shanghai Branch Office

Location: Room 311, Building 6, TEEC Shanghai Center, 599 Lane, Yungu
Road, Jiading District, Shanghai, China

Mobile: 18916488006

Contact: Mr. Zhou