

Pb THIS PRODUCT MANUFACTURED WITH LEAD-FREE PROCESSING

DESIGNED & DIMENSIONED IN MILLIMETERS [INCHES]

SCPU-17-X-XX.XX-XXX-XXX

DO NOT SCALE FROM THIS PRINT

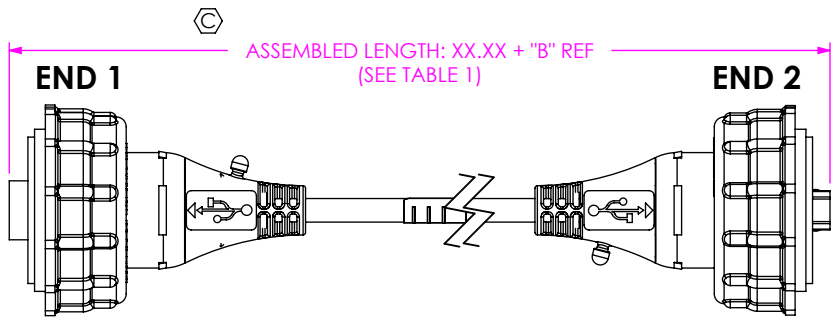

PLATING
-G: .000030" GOLD ON CONTACT AREAS, NICKEL ON SHELLS

LENGTH
-XX.XX (SEE TABLE 1)
(00.25M [9.842] MIN - 50.00M [1968.504] MAX) (SEE NOTE 22)

END 1 OPTIONS
-AMS: SEALED USB A (USB A END SEALED ONLY)
-BMS: SEALED USB B (USB B END SEALED ONLY)

END 2 OPTIONS
-AMS: SEALED USB A (USB A END SEALED ONLY) (SEE SHEETS 1-3 & 11)
-BMS: SEALED USB B (USB B END SEALED ONLY) (SEE SHEETS 1-3 & 11)
-AM: USB A NOT SEALED (USB A END NOT SEALED ONLY) (SEE SHEET 2)
-BM: USB B NOT SEALED (USB B END NOT SEALED ONLY) (SEE SHEET 2)
-BC: BLUNT CUT (SEE SHEET 3)

NOTE:
-02.00, -03.00, AND -05.00 ARE CATALOG STANDARD LENGTHS. FOR OTHER LENGTHS (0.17M[6.69] MIN - 50.00M[1968.50] MAX) CONTACT SAMTEC.

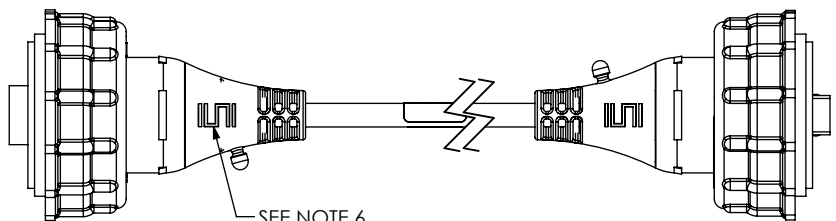
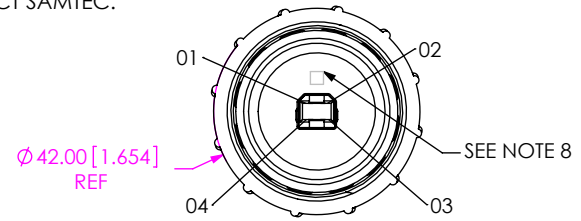
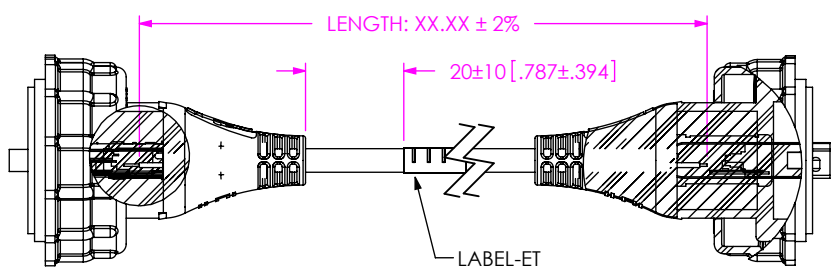
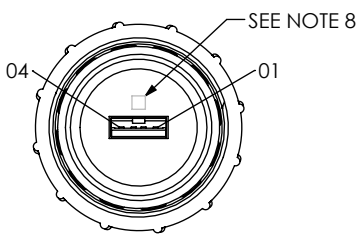

FIG 1
SCPU-17-G-XX.XX-AMS-BMS SHOWN

NOTES:

1. Ⓢ REPRESENTS A CRITICAL DIMENSION.
2. NOTE DELETED.
3. SURFACE TO BE RECESSED 0.22[.009].
4. USB LOGO TO BE RAISED 0.25[.010]. USB LOGO TO BE PRINTED IN WHITE.
5. USB LOGO'S TO BE ALIGNED TO USB CONNECTORS AS SHOWN.
6. SAMTEC LOGO TO APPEAR ON SURFACE AS SHOWN, APPROXIMATELY 4.50[.177] x 7.50[.295], RAISED 0.25[.010].
7. NOTE DELETED.
8. ALL MULTIPLE CAVITY MOLDS SHALL IDENTIFY EACH CAVITY WITH A NUMBER DESIGNATION LOCATED WHERE SHOWN.
9. ALL IDENTIFICATION MARKS MUST NOT STAND GREATER THAN 0.051[.002] OFF THE SURFACE OF THE PART.
10. MOLD TO BE INSERTED TO ACCEPT DIFFERENT CABLE DIAMETERS.
11. ASSEMBLY TO BE 100% TESTED FOR OPENS AND SHORTS, HI-POT TESTED AT 200V BEFORE PREMOLD AND AFTER FINAL ASSEMBLY IS COMPLETE. AFTER FINAL ELECTRICAL TEST, LABEL EACH ASSEMBLY WITH 1 LABEL-ET.
12. ALL EJECTOR PIN AND GATE LOCATIONS MUST BE APPROVED BY SAMTEC PRODUCT ENGINEERING.
13. ANY ADDITIONAL VOIDING AND/OR MODIFICATIONS TO VOIDING MUST BE APPROVED BY SAMTEC PRODUCT ENGINEERING.
14. ALL DRAFT MUST BE WITHIN THE SPECIFIED TOLERANCES.
15. ALL INSIDE/OUTSIDE RADII 0.13 MAX UNLESS OTHERWISE STATED.
16. NOTE DELETED.
17. NOTE DELETED.
18. ASSEMBLY TO BE SHIPPED IN BULK PACKAGING.
19. THIS IS A COMPONENT OF USBP-A-01-G-B-01 (CALLED OUT ON THE BOM), BUT LABELLED INDIVIDUALLY FOR ASSEMBLY PURPOSES.
20. THIS IS A COMPONENT OF USBP-B-01-G-B-01 (CALLED OUT ON THE BOM), BUT LABELLED INDIVIDUALLY FOR ASSEMBLY PURPOSES.
21. TORQUE SPECIFICATION FOR SCN-17-01 IS 12 IN-LBS.
22. LENGTHS GREATER THAN 05.00 ARE NOT SUPPORTED BY USB 2.0 TEST DATA.
23. NOTE DELETED.

TABLE 1		
PART NUMBER	END 2	"B"
SCPU-17-XX-XX-AMS-	AMS	36.5 [1.45]
	BMS	36.5 [1.45]
	AM	36.5 [1.45]
	BM	36.5 [1.45]
	MB	36.5 [1.45]
SCPU-17-XX-XX-BMS-	BC	18.25 [.718]
	AMS	36.5 [1.45]
	BMS	36.5 [1.45]
	AM	36.5 [1.45]
	BM	36.5 [1.45]
	MB	36.5 [1.45]
	BC	18.25 [.718]

UNLESS OTHERWISE SPECIFIED, DIMENSIONS ARE IN MILLIMETERS.

TOLERANCES ARE:
DECIMALS ANGLES
0.X: ±0.35 [.014] 2°
0.XX: ±0.25 [.010]
0.XXX: ±0.15 [.006]

PROPRIETARY NOTE
THIS DOCUMENT CONTAINS CONFIDENTIAL AND PROPRIETARY INFORMATION AND ALL DESIGN, MANUFACTURING, REPRODUCTION, USE, PATENT RIGHTS AND SALES RIGHTS ARE EXPRESSLY RESERVED BY SAMTEC, INC. THIS DOCUMENT SHALL NOT BE DISCLOSED, IN WHOLE OR PART, TO ANY UNAUTHORIZED PERSON OR ENTITY NOR REPRODUCED, TRANSFERRED OR INCORPORATED IN ANY OTHER PROJECT IN ANY MANNER WITHOUT THE EXPRESS WRITTEN CONSENT OF SAMTEC, INC.

MATERIAL: DO NOT SCALE DRAWING SHEET SCALE: 0.65:1
INSULATOR: GLASS FILLED THERMOPLASTIC
CONTACTS: COPPER ALLOY
SHIELDS: CRS, CABLE NUT: PA66
SEALED PREMOLD: RITEFLEX 640A
NON-SEALED PREMOLD: N/A
SEALED OVERMOLD: PA66 GF13 FR/ SHOT WEIGHT: 12.71 g [0.280 lb]
NON SEALED OVERMOLD: PVC/ SHOT WEIGHT: 9.07 g [0.200 lb]
c:\enterprise\vaull\DWG\MISC\MKTG\SCPU-17-X-XX-XX-XXX-MKT.SLDDRW



520 PARK EAST BLVD, NEW ALBANY, IN 47150
PHONE: 812-944-6733 FAX: 812-948-5047
e-Mail info@SAMTEC.com code 55322

DESCRIPTION:
SEALED CIRCULAR CABLE PLUG, USB
DWG. NO.
SCPU-17-X-XX.XX-XXX-XXX
BY: CHAD F 12/8/2004 SHEET 1 OF 10

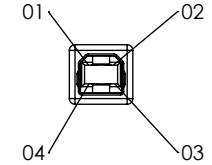
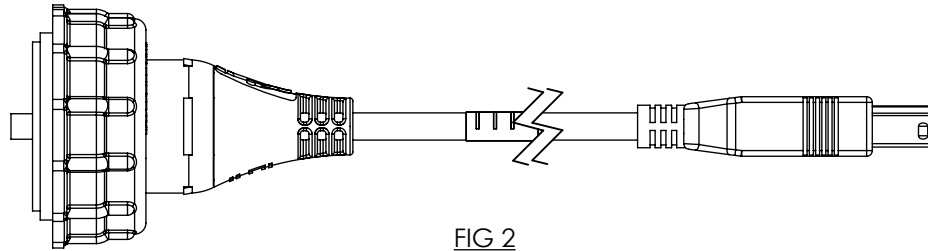
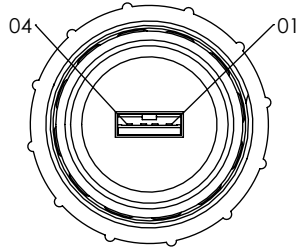
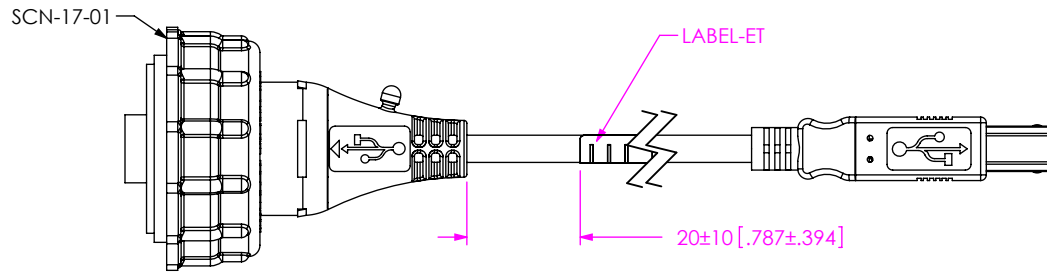

FIG 2
SCPU-17-G-XX.XX-AMS-BM SHOWN
(SAME AS FIG 1, UNLESS OTHERWISE STATED)

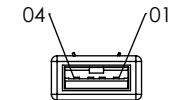
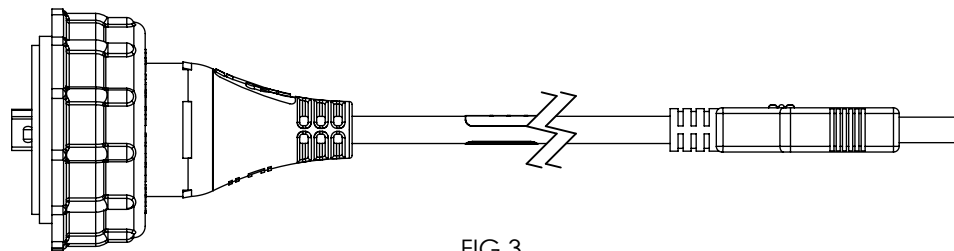
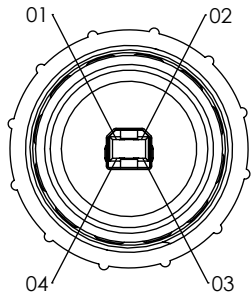
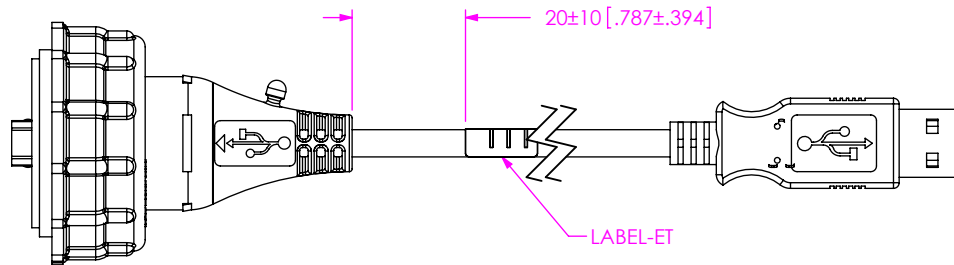

FIG 3
SCPU-17-G-XX.XX-BMS-AM SHOWN
(SAME AS FIG 1, UNLESS OTHERWISE STATED)

PROPRIETARY NOTE
THIS DOCUMENT CONTAINS CONFIDENTIAL AND PROPRIETARY INFORMATION AND ALL DESIGN, MANUFACTURING, REPRODUCTION, USE, PATENT RIGHTS AND SALES RIGHTS ARE EXPRESSLY RESERVED BY SAMTEC, INC. THIS DOCUMENT SHALL NOT BE DISCLOSED, IN WHOLE OR PART, TO ANY UNAUTHORIZED PERSON OR ENTITY NOR REPRODUCED, TRANSFERRED OR INCORPORATED IN ANY OTHER PROJECT IN ANY MANNER WITHOUT THE EXPRESS WRITTEN CONSENT OF SAMTEC, INC.

DO NOT SCALE DRAWING

SHEET SCALE: 3:4

samtec

520 PARK EAST BLVD, NEW ALBANY, IN 47150
PHONE: 812-944-6733 FAX: 812-948-5047
e-Mail info@SAMTEC.com code 55322

DESCRIPTION:
SEALED CIRCULAR CABLE PLUG, USB

DWG. NO.
SCPU-17-X-XX.XX-XXX-XXX

BY: CHAD F 12/8/2004 SHEET 2 OF 10

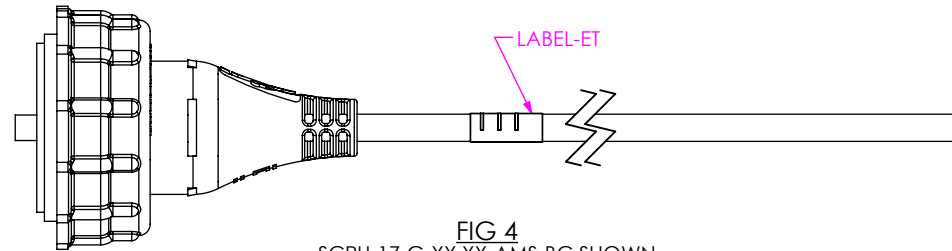
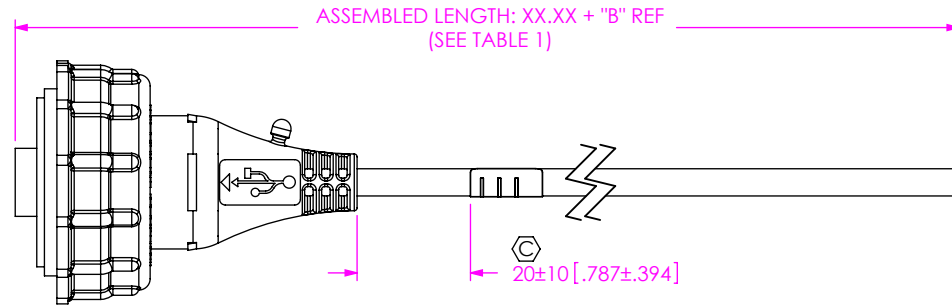
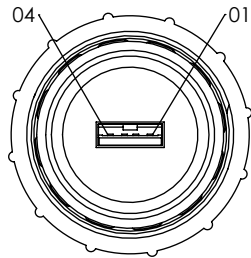

FIG 4
SCPU-17-G-XX.XX-AMS-BC SHOWN
(SAME AS FIG 1, UNLESS OTHERWISE STATED)

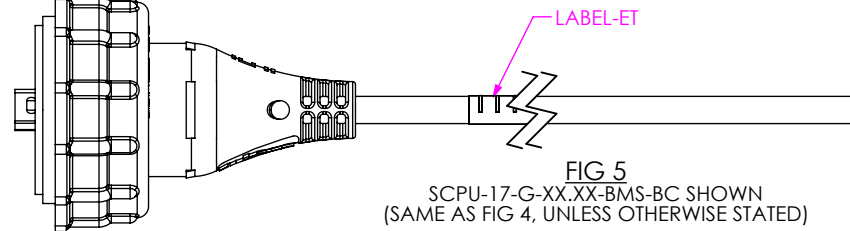
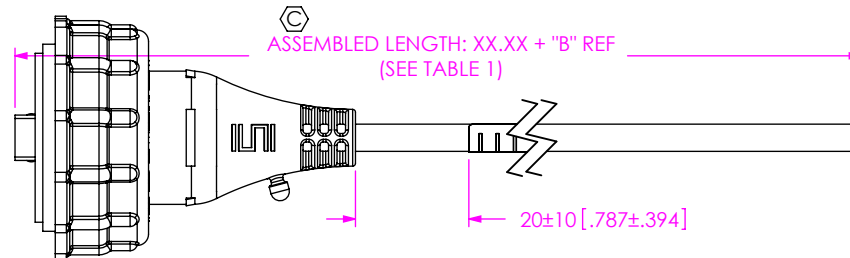
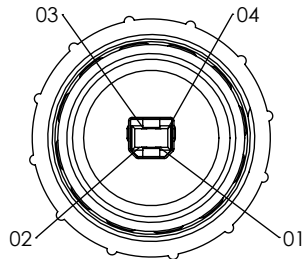

FIG 5
SCPU-17-G-XX.XX-BMS-BC SHOWN
(SAME AS FIG 4, UNLESS OTHERWISE STATED)

PROPRIETARY NOTE
THIS DOCUMENT CONTAINS CONFIDENTIAL AND PROPRIETARY INFORMATION AND ALL DESIGN, MANUFACTURING, REPRODUCTION, USE, PATENT RIGHTS AND SALES RIGHTS ARE EXPRESSLY RESERVED BY SAMTEC, INC. THIS DOCUMENT SHALL NOT BE DISCLOSED, IN WHOLE OR PART, TO ANY UNAUTHORIZED PERSON OR ENTITY NOR REPRODUCED, TRANSFERRED OR INCORPORATED IN ANY OTHER PROJECT IN ANY MANNER WITHOUT THE EXPRESS WRITTEN CONSENT OF SAMTEC, INC.

DO NOT SCALE DRAWING

SHEET SCALE: 3:4

samtec

520 PARK EAST BLVD, NEW ALBANY, IN 47150
PHONE: 812-944-6733 FAX: 812-948-5047
e-Mail info@SAMTEC.com code 55322

DESCRIPTION:
SEALED CIRCULAR CABLE PLUG, USB

DWG. NO.
SCPU-17-X-XX.XX-XXX-XXX

BY: CHAD F 12/8/2004 SHEET 3 OF 10

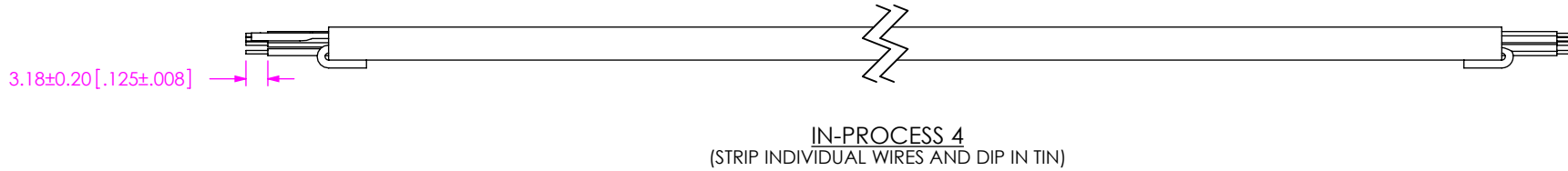
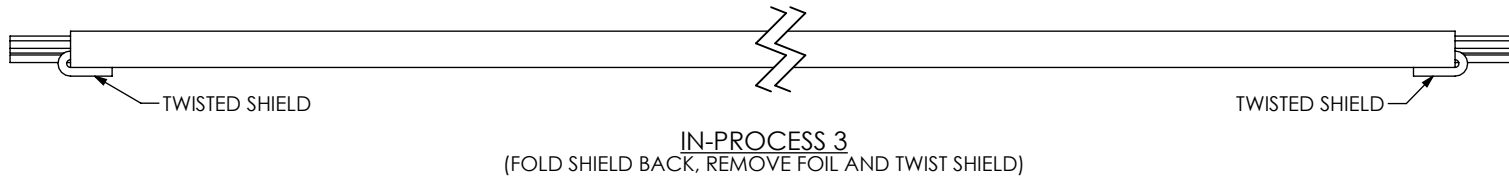
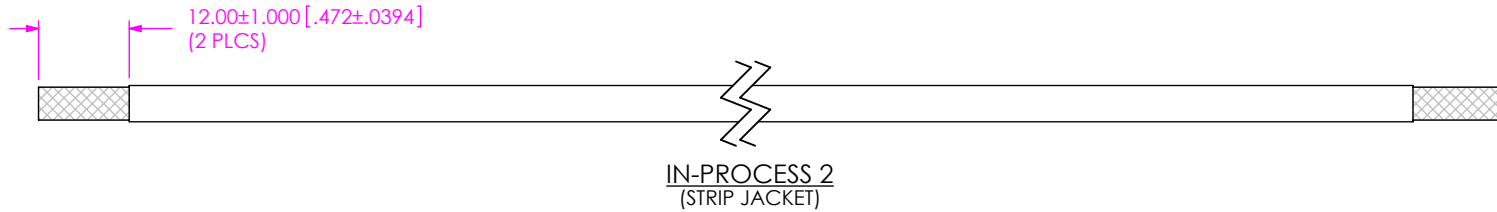
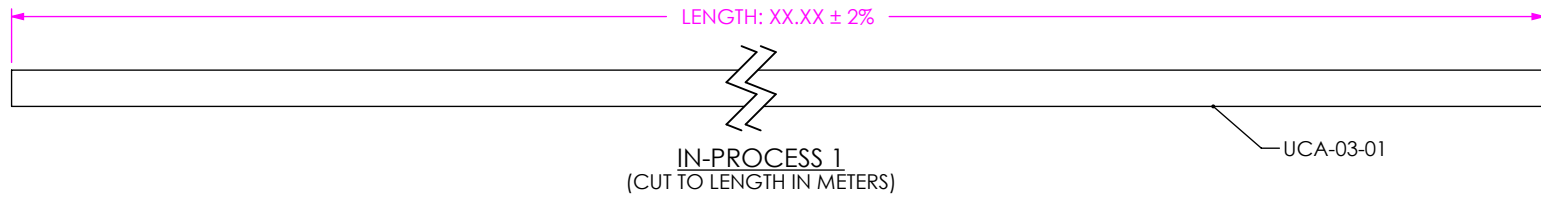

TABLE 2: PIN-OUT

END 1		Wire Color	END 2		-AM	-BM	-BC	-MB
-AMS	-BMS		-AMS	-BMS				
01	01	RED	01	01	01	01	01	01
02	02	WHITE	02	02	02	02	02	02
03	03	GREEN	03	03	03	03	03	03
n/a	n/a	NOT CONNECTED	n/a	n/a	n/a	n/a	n/a	04
04	04	BLACK	04	04	04	04	04	05
USB Shield	USB Shield	DRAIN/CABLE SHIELD	USB Shield	USB Shield	USB Shield	USB Shield	USB Shield	USB Shield

* **PROPRIETARY NOTE** *

THIS DOCUMENT CONTAINS CONFIDENTIAL AND PROPRIETARY INFORMATION AND ALL DESIGN, MANUFACTURING, REPRODUCTION, USE, PATENT RIGHTS AND SALES RIGHTS ARE EXPRESSLY RESERVED BY SAMTEC, INC. THIS DOCUMENT SHALL NOT BE DISCLOSED, IN WHOLE OR PART, TO ANY UNAUTHORIZED PERSON OR ENTITY NOR REPRODUCED, TRANSFERRED OR INCORPORATED IN ANY OTHER PROJECT IN ANY MANNER WITHOUT THE EXPRESS WRITTEN CONSENT OF SAMTEC, INC.

DO NOT SCALE DRAWING

SHEET SCALE: 1:1.33333



520 PARK EAST BLVD, NEW ALBANY, IN 47150
PHONE: 812-944-6733 FAX: 812-948-5047
e-Mail info@SAMTEC.com code 55322

DESCRIPTION:
SEALED CIRCULAR CABLE PLUG, USB

DWG. NO.
SCPU-17-X-XX.XX-XXX-XXX

BY: CHAD F 12/8/2004 SHEET 4 OF 10

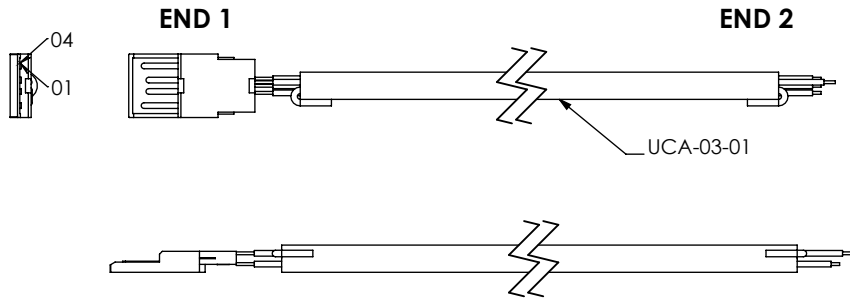

IN-PROCESS 5
TERMINATE TO SUB-USB-A-G-B-01 (SEE NOTE 19)

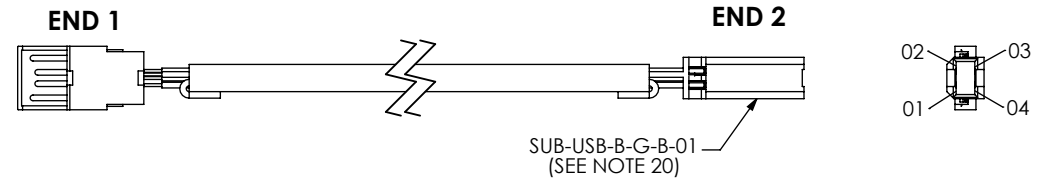

IN-PROCESS 6
TERMINATE TO SUB-USB-B-G-B-01 (SEE NOTE 20)

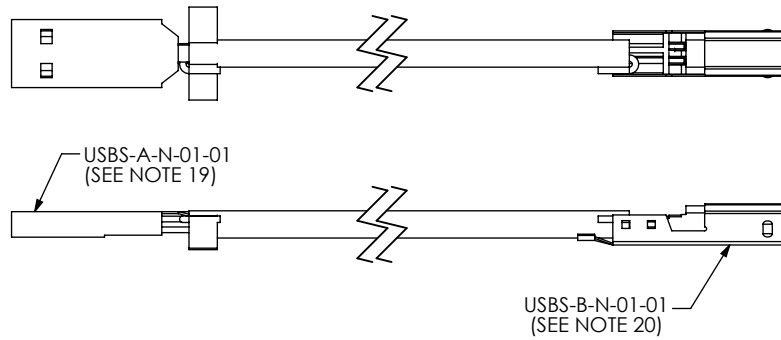

IN-PROCESS 7
ADD USBS-A-N-01-01 (SEE NOTE 19) & USBS-B-N-01-01 (SEE NOTE 20) SHELLS

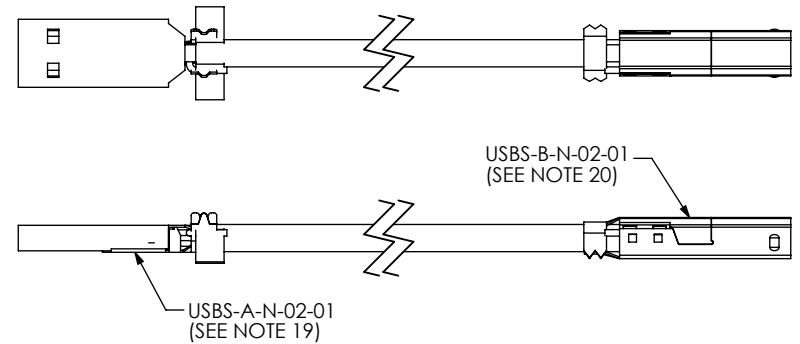

IN-PROCESS 8
ADD USBS-A-N-02-01 (SEE NOTE 19) & USBS-B-N-02-01 (SEE NOTE 20) SHELLS

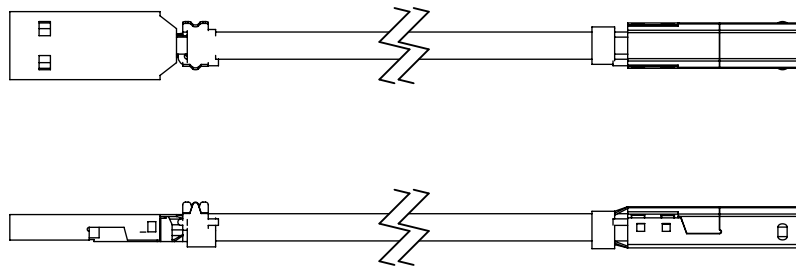

IN-PROCESS 9
CRIMP SHELLS OVER BRAID AND TRIM EXCESS SHIELD

PROPRIETARY NOTE
* THIS DOCUMENT CONTAINS CONFIDENTIAL AND PROPRIETARY INFORMATION AND ALL DESIGN, MANUFACTURING, REPRODUCTION, USE, PATENT RIGHTS AND SALES RIGHTS ARE EXPRESSLY RESERVED BY SAMTEC, INC. THIS DOCUMENT SHALL NOT BE DISCLOSED, IN WHOLE OR PART, TO ANY UNAUTHORIZED PERSON OR ENTITY NOR REPRODUCED, TRANSFERRED OR INCORPORATED IN ANY OTHER PROJECT IN ANY MANNER WITHOUT THE EXPRESS WRITTEN CONSENT OF SAMTEC, INC.

DO NOT SCALE DRAWING

SHEET SCALE: 1:1.33333

samtec

520 PARK EAST BLVD, NEW ALBANY, IN 47150
PHONE: 812-944-6733 FAX: 812-948-5047
e-Mail info@SAMTEC.com code 55322

DESCRIPTION:
SEALED CIRCULAR CABLE PLUG, USB

DWG. NO.
SCPU-17-X-XX.XX-XXX-XXX

BY: CHAD F 12/8/2004 SHEET 5 OF 10

REVISION AA

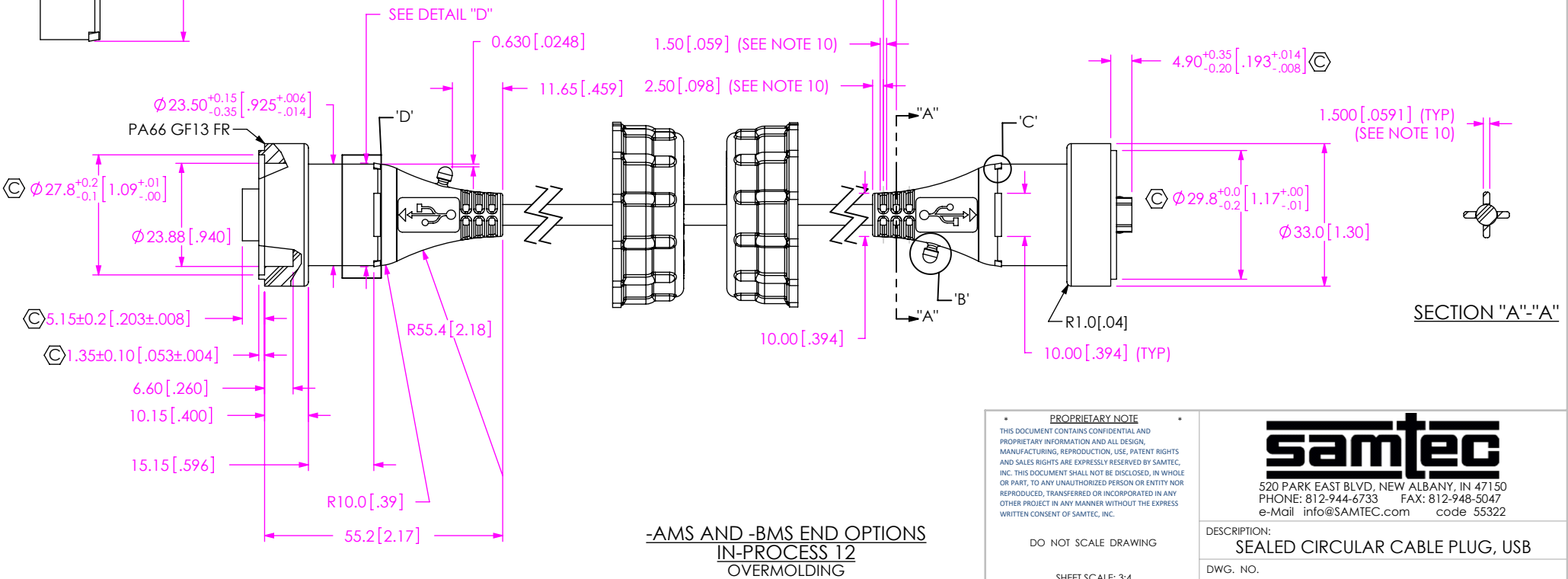
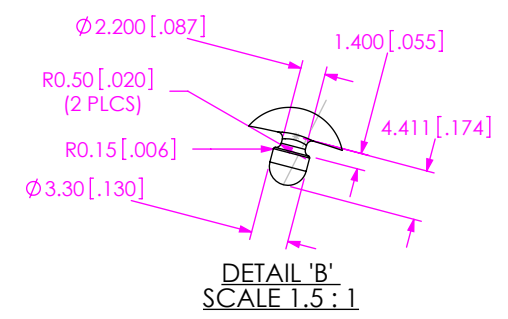
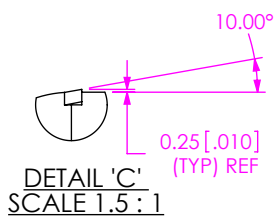
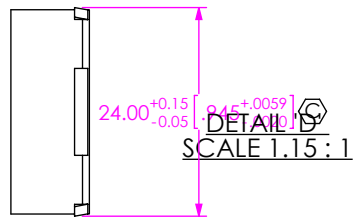
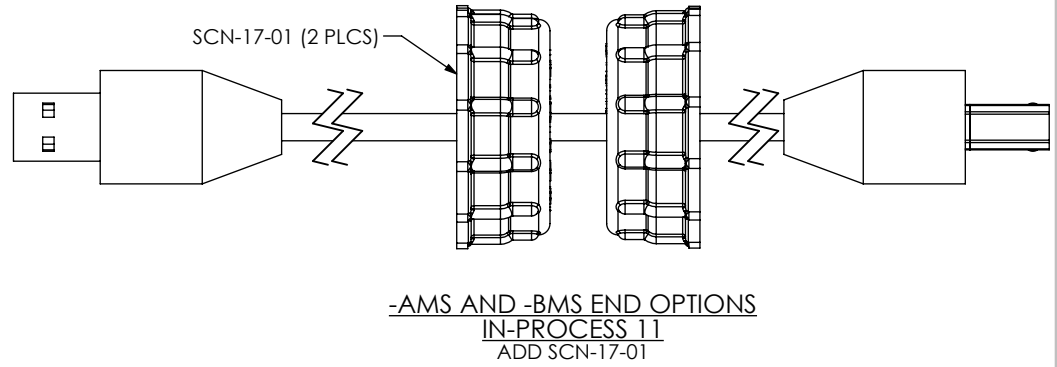
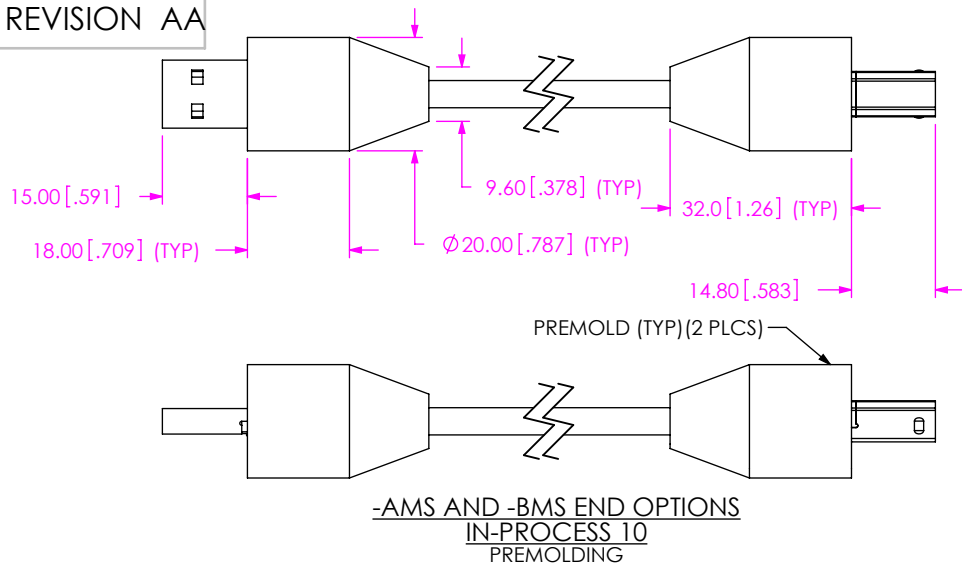

PROPRIETARY NOTE
THIS DOCUMENT CONTAINS CONFIDENTIAL AND PROPRIETARY INFORMATION AND ALL DESIGN, MANUFACTURING, REPRODUCTION, USE, PATENT RIGHTS AND SALES RIGHTS ARE EXPRESSLY RESERVED BY SAMTEC, INC. THIS DOCUMENT SHALL NOT BE DISCLOSED, IN WHOLE OR PART, TO ANY UNAUTHORIZED PERSON OR ENTITY NOR REPRODUCED, TRANSFERRED OR INCORPORATED IN ANY OTHER PROJECT IN ANY MANNER WITHOUT THE EXPRESS WRITTEN CONSENT OF SAMTEC, INC.

samtec
520 PARK EAST BLVD, NEW ALBANY, IN 47150
PHONE: 812-944-6733 FAX: 812-948-5047
e-Mail info@SAMTEC.com code 55322

DO NOT SCALE DRAWING
SHEET SCALE: 3:4

DESCRIPTION:	SEALED CIRCULAR CABLE PLUG, USB
DWG. NO.	SCPU-17-X-XX.XX-XXX-XXX
BY:	CHAD F 12/8/2004 SHEET 6 OF 10

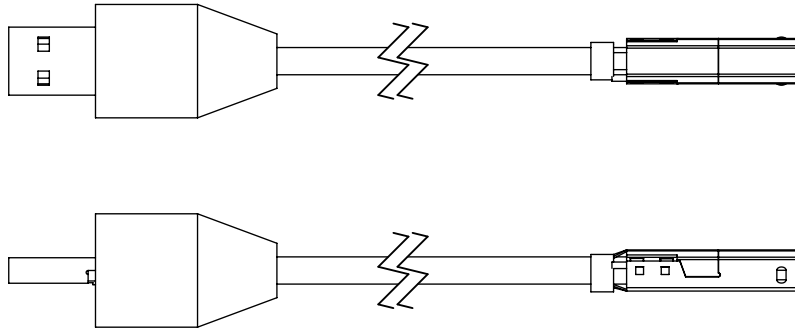

**-BM END OPTION
IN-PROCESS 10
PREMOLDING**

(SAME AS -AMS AND -BMS END OPTIONS IN-PROCESS 10, UNLESS OTHERWISE STATED)

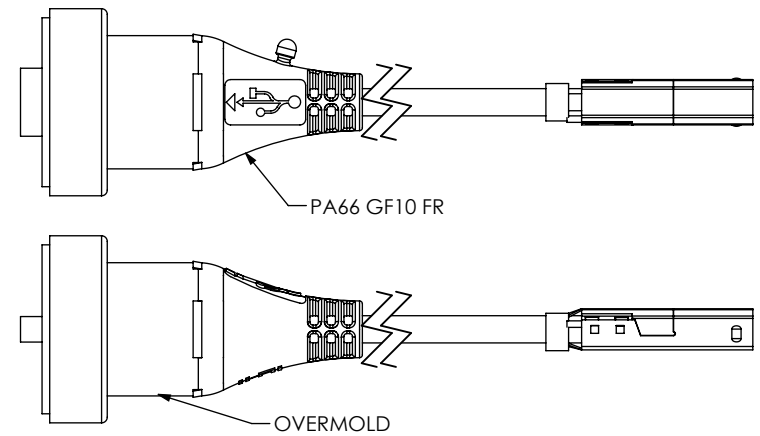

**-BM END OPTION
IN-PROCESS 11
OVERMOLDING**

(SAME AS -AMS AND -BMS END OPTIONS IN-PROCESS 11, UNLESS OTHERWISE STATED)

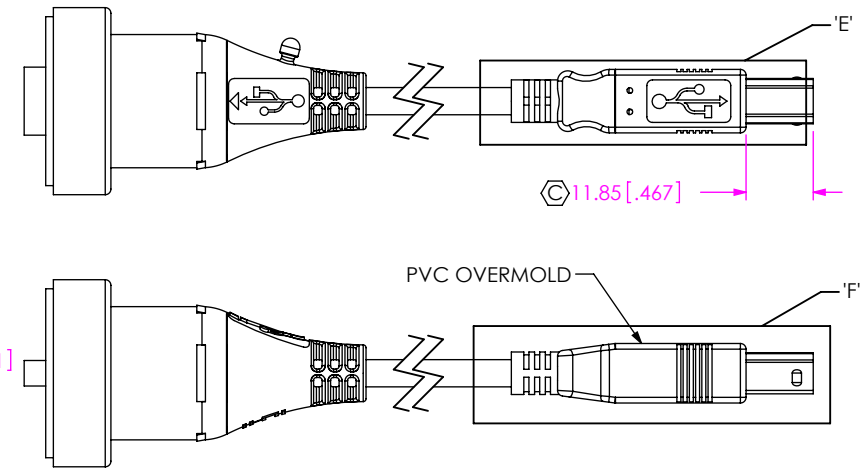
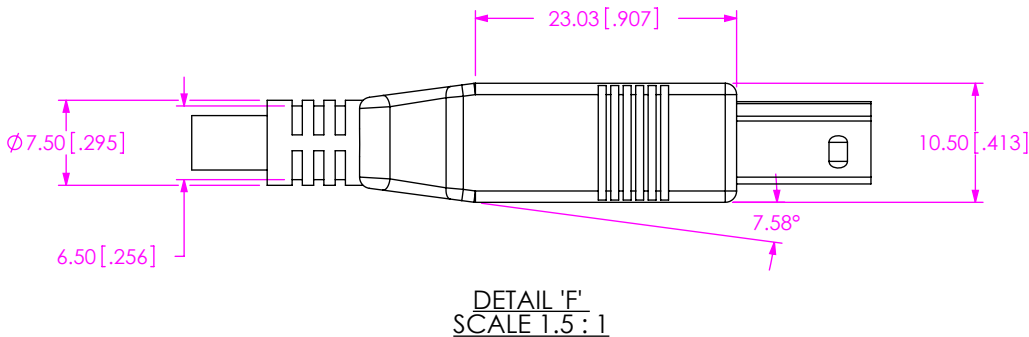
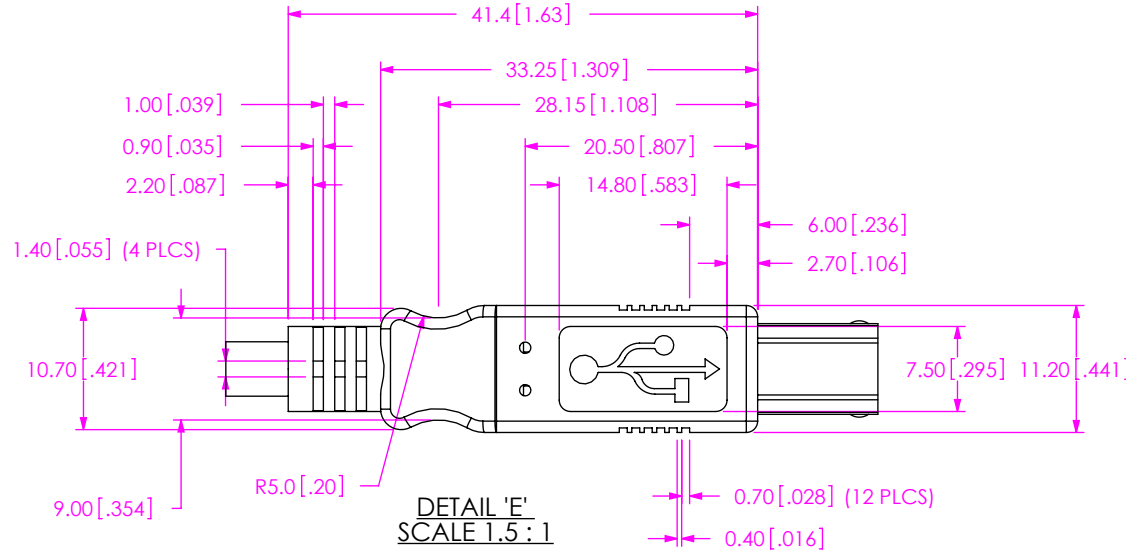

**-BM END OPTION
IN-PROCESS 12
NON-SEALED OVERMOLDING**

(SAME AS -AMS AND -BMS END OPTIONS IN PROCESS 12, UNLESS OTHERWISE STATED)

PROPRIETARY NOTE

THIS DOCUMENT CONTAINS CONFIDENTIAL AND PROPRIETARY INFORMATION AND ALL DESIGN, MANUFACTURING, REPRODUCTION, USE, PATENT RIGHTS AND SALES RIGHTS ARE EXPRESSLY RESERVED BY SAMTEC, INC. THIS DOCUMENT SHALL NOT BE DISCLOSED, IN WHOLE OR PART, TO ANY UNAUTHORIZED PERSON OR ENTITY NOR REPRODUCED, TRANSFERRED OR INCORPORATED IN ANY OTHER PROJECT IN ANY MANNER WITHOUT THE EXPRESS WRITTEN CONSENT OF SAMTEC, INC.

DO NOT SCALE DRAWING

SHEET SCALE: 3:4



520 PARK EAST BLVD, NEW ALBANY, IN 47150
PHONE: 812-944-6733 FAX: 812-948-5047
e-Mail info@SAMTEC.com code 55322

DESCRIPTION:
SEALED CIRCULAR CABLE PLUG, USB

DWG. NO.
SCPU-17-X-XX.XX-XXX-XXX

BY: CHAD F 12/8/2004 SHEET 7 OF 10

REVISION AA

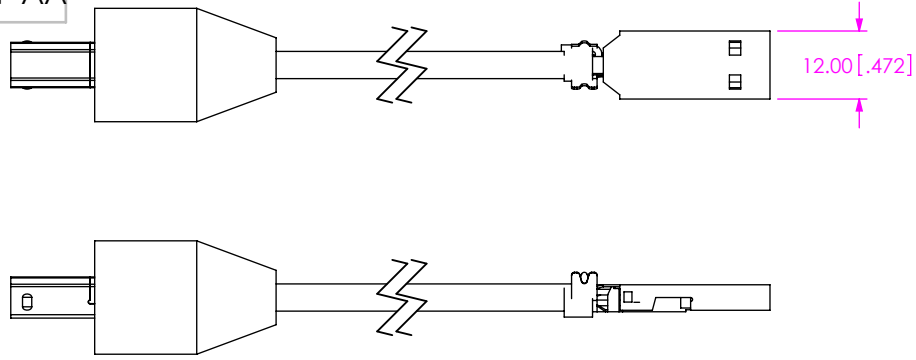

**-AM END OPTION
IN-PROCESS 10
PREMOLDING**
(SAME AS -AMS AND -BMS END OPTIONS IN-PROCESS 10, UNLESS OTHERWISE STATED)

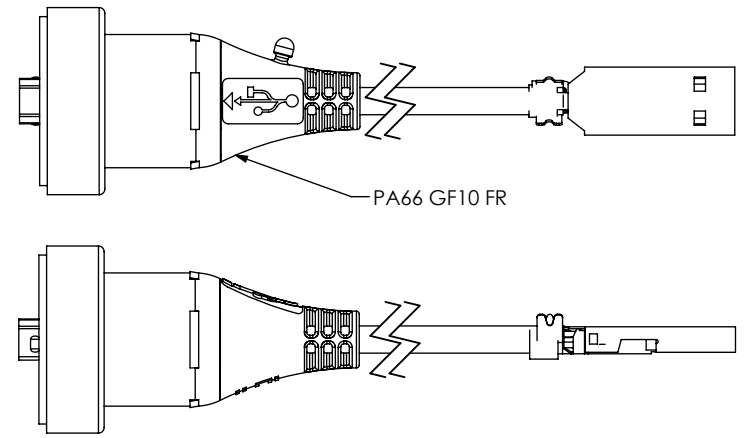

**-AM END OPTION
IN-PROCESS 11
OVERMOLDING**
(SAME AS -AMS AND -BMS END OPTIONS IN-PROCESS 11, UNLESS OTHERWISE STATED)

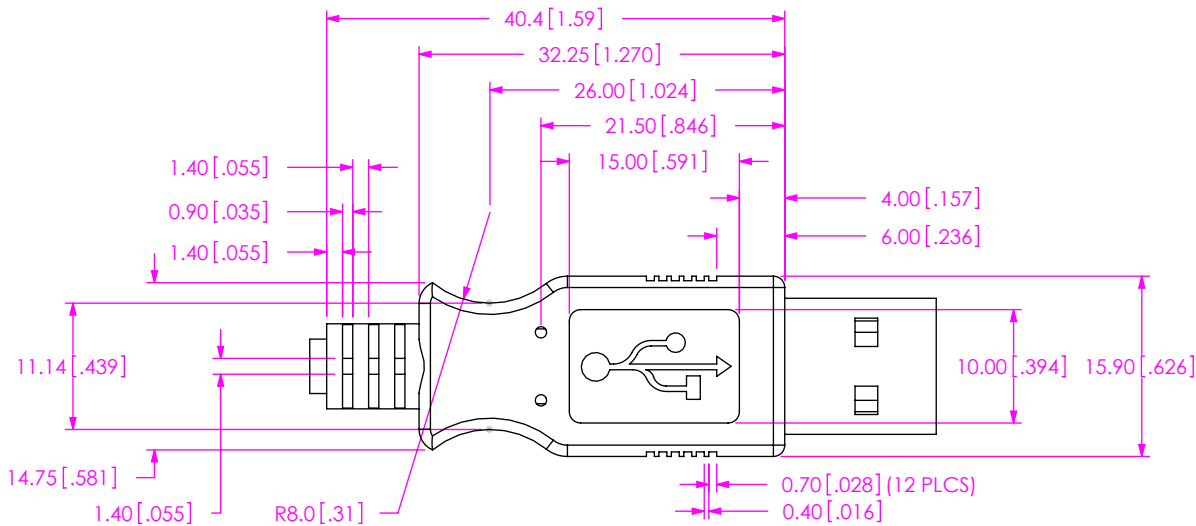

**DETAIL 'G'
SCALE 1.5 : 1**

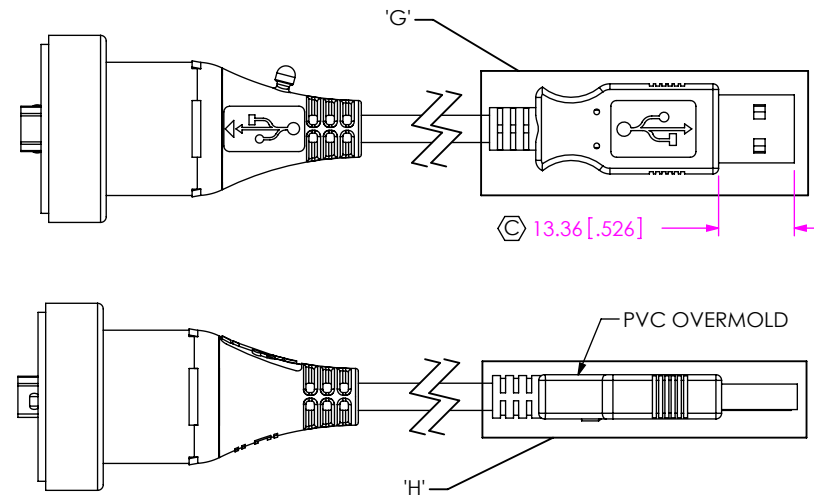

**-AM END OPTION
IN-PROCESS 12
NON-SEALED OVERMOLDING**
(SAME AS -AMS AND -BMS END OPTIONS IN-PROCESS 12, UNLESS OTHERWISE STATED)

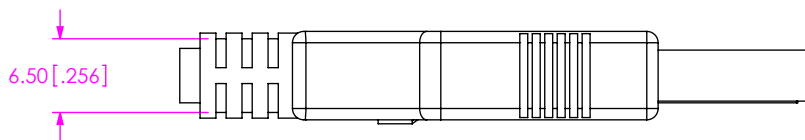

**DETAIL 'H'
SCALE 1.5 : 1**

PROPRIETARY NOTE
THIS DOCUMENT CONTAINS CONFIDENTIAL AND PROPRIETARY INFORMATION AND ALL DESIGN, MANUFACTURING, REPRODUCTION, USE, PATENT RIGHTS AND SALES RIGHTS ARE EXPRESSLY RESERVED BY SAMTEC, INC. THIS DOCUMENT SHALL NOT BE DISCLOSED, IN WHOLE OR PART, TO ANY UNAUTHORIZED PERSON OR ENTITY NOR REPRODUCED, TRANSFERRED OR INCORPORATED IN ANY OTHER PROJECT IN ANY MANNER WITHOUT THE EXPRESS WRITTEN CONSENT OF SAMTEC, INC.

DO NOT SCALE DRAWING

SHEET SCALE: 3:4

samtec

520 PARK EAST BLVD., NEW ALBANY, IN 47150
PHONE: 812-944-6733 FAX: 812-948-5047
e-Mail: info@SAMTEC.com code 55322

DESCRIPTION:
SEALED CIRCULAR CABLE PLUG, USB

DWG. NO.
SCPU-17-X-XX.XX-XXX-XXX

BY: CHAD F 12/8/2004 SHEET 8 OF 10

IN-PROCESS VIEWS FOR -AMS AND -AMS AND -BC END OPTIONS

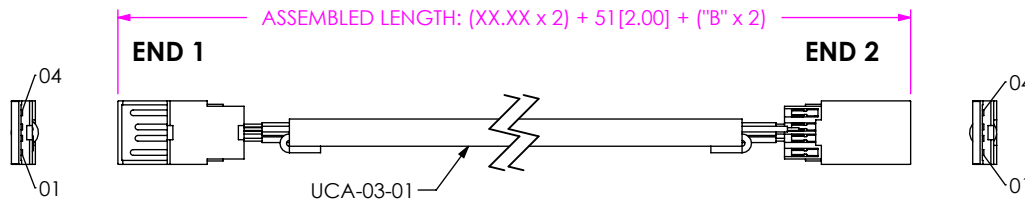

IN-PROCESS 5
 TERMINATE TO SUB-USB-A-G-B-01 (SEE NOTE 19)
 (SAME AS -AMS AND -BMS END OPTIONS IN-PROCESS 5, UNLESS OTHERWISE STATED)

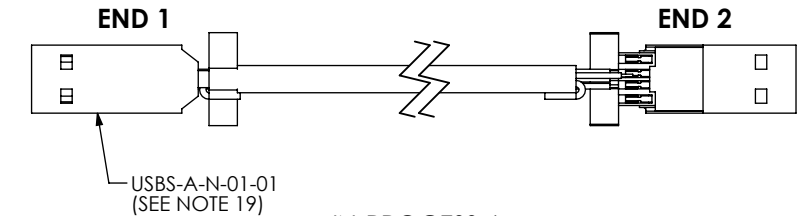

IN-PROCESS 6
 ADD USB-A-N-01-01 SHELL
 (SAME AS -AMS AND -BMS END OPTIONS IN-PROCESS 7, UNLESS OTHERWISE STATED)



IN-PROCESS 7
 ADD USB-A-N-02-01 SHELL
 (SAME AS -AMS AND -BMS END OPTIONS IN-PROCESS 8, UNLESS OTHERWISE STATED)



IN-PROCESS 10
 ADD SCN-17-01
 (SAME AS -AMS AND -BMS END OPTIONS IN-PROCESS 11, UNLESS OTHERWISE STATED)

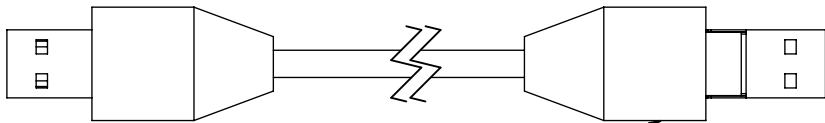

IN-PROCESS 9
 PREMOLDING
 (SAME AS -AMS AND -BMS END OPTIONS IN-PROCESS 10, UNLESS OTHERWISE STATED)

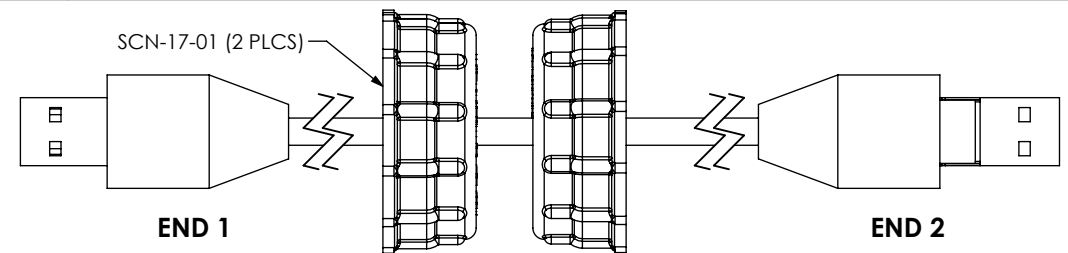

IN-PROCESS 8
 CRIMP SHELLS OVER BRAID
 (SAME AS -AMS AND -BMS END OPTIONS IN-PROCESS 9, UNLESS OTHERWISE STATED)

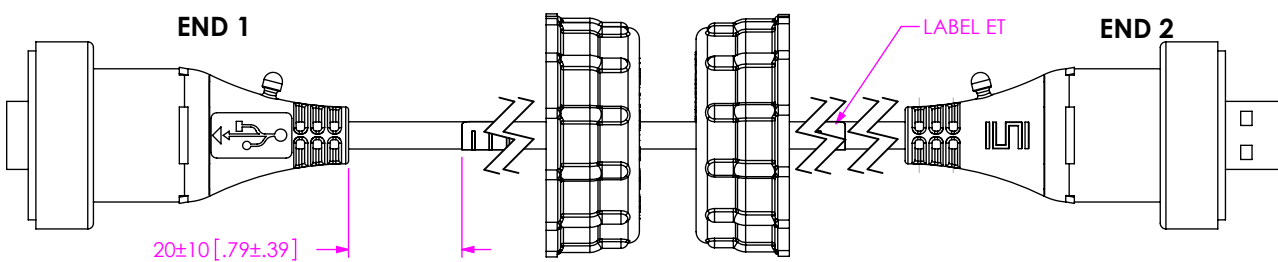

IN-PROCESS 11
 OVERMOLDING
 (SAME AS -AMS AND -BMS END OPTIONS IN-PROCESS 12, UNLESS OTHERWISE STATED)

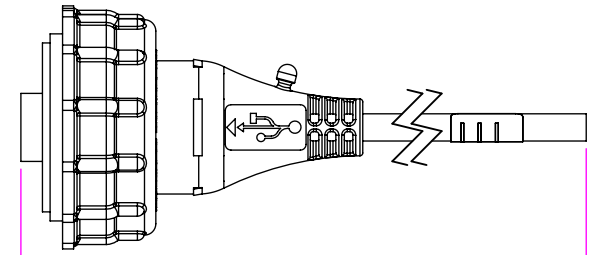

IN-PROCESS 12
 (CUT IN HALF AND TRIM TO LENGTH)

PROPRIETARY NOTE
 THIS DOCUMENT CONTAINS CONFIDENTIAL AND PROPRIETARY INFORMATION AND ALL DESIGN, MANUFACTURING, REPRODUCTION, USE, PATENT RIGHTS AND SALES RIGHTS ARE EXPRESSLY RESERVED BY SAMTEC, INC. THIS DOCUMENT SHALL NOT BE DISCLOSED, IN WHOLE OR PART, TO ANY UNAUTHORIZED PERSON OR ENTITY NOR REPRODUCED, TRANSFERRED OR INCORPORATED IN ANY OTHER PROJECT IN ANY MANNER WITHOUT THE EXPRESS WRITTEN CONSENT OF SAMTEC, INC.

DO NOT SCALE DRAWING
 SHEET SCALE: 3:4



520 PARK EAST BLVD, NEW ALBANY, IN 47150
 PHONE: 812-944-6733 FAX: 812-948-5047
 e-Mail info@SAMTEC.com code 55322

DESCRIPTION:
 SEALED CIRCULAR CABLE PLUG, USB
 DWG. NO.
 SCPU-17-X-XX.XX-XXX-XXX
 BY: CHAD F 12/8/2004 SHEET 9 OF 10

IN-PROCESS VIEWS FOR -BMS AND -BMS AND -BC END OPTION

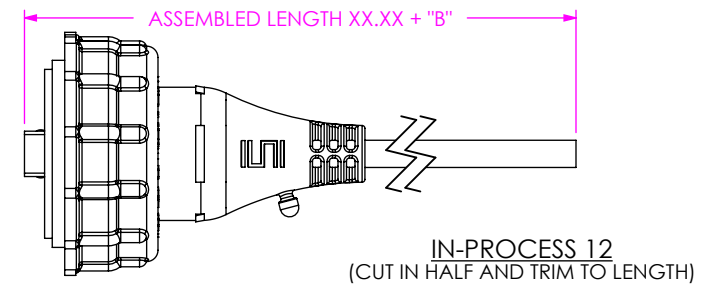
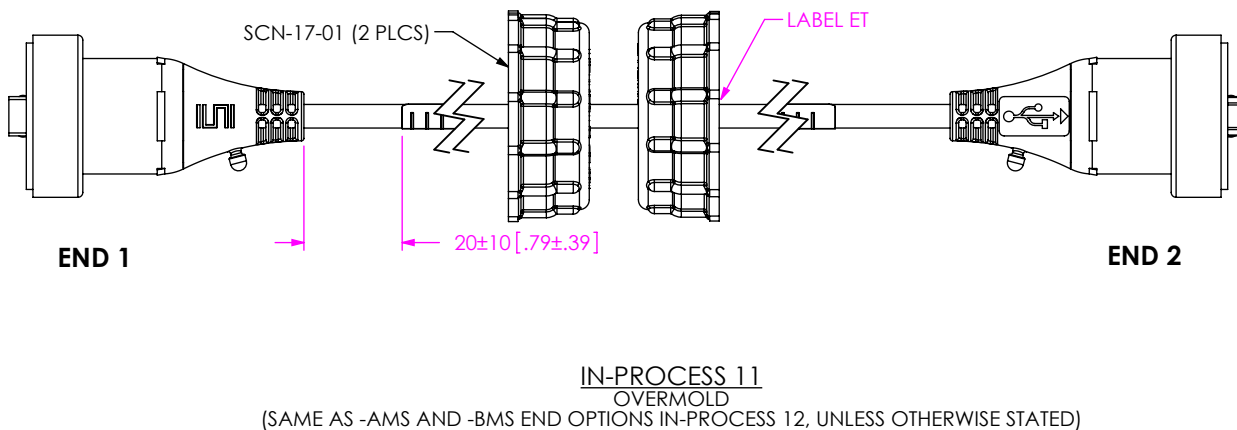
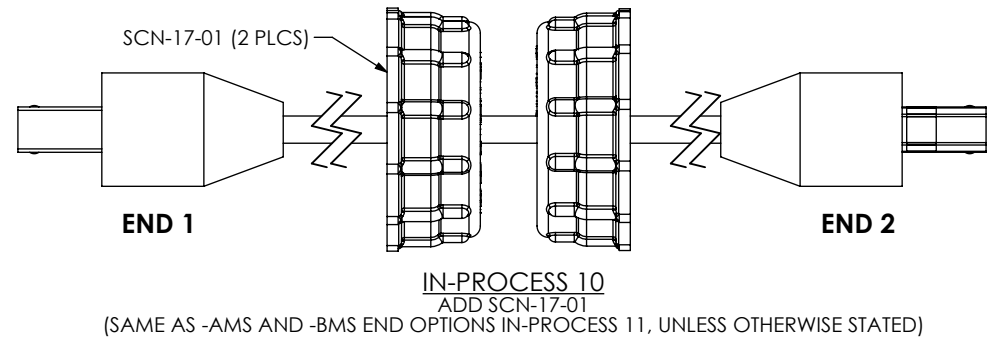
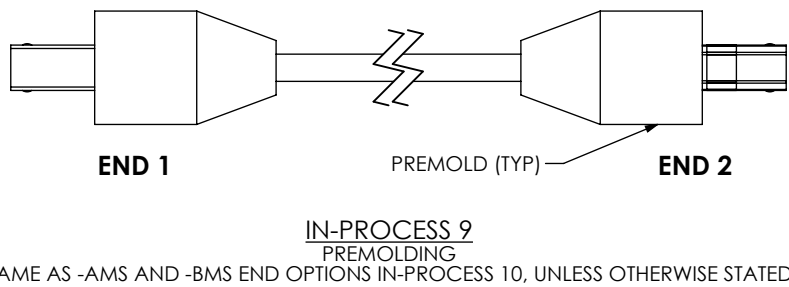
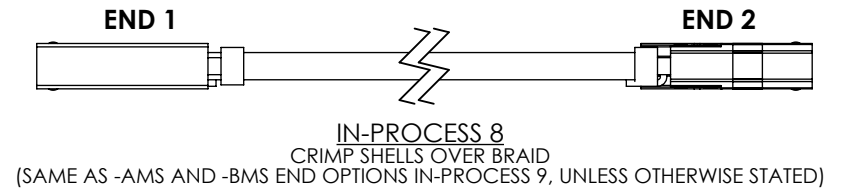
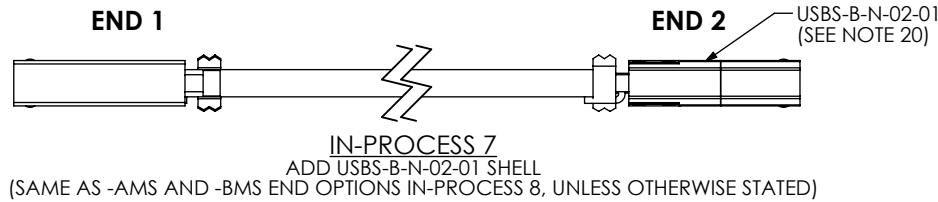
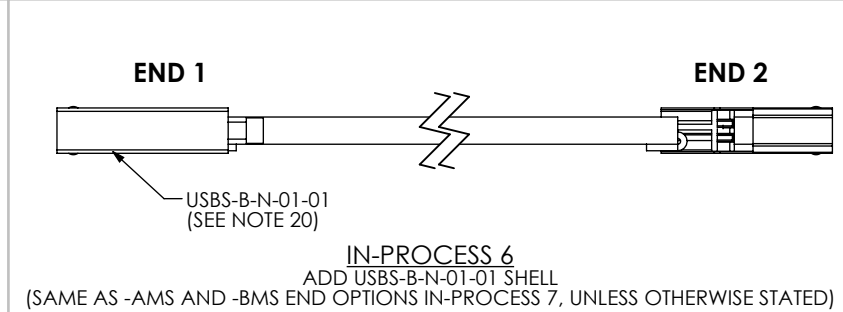
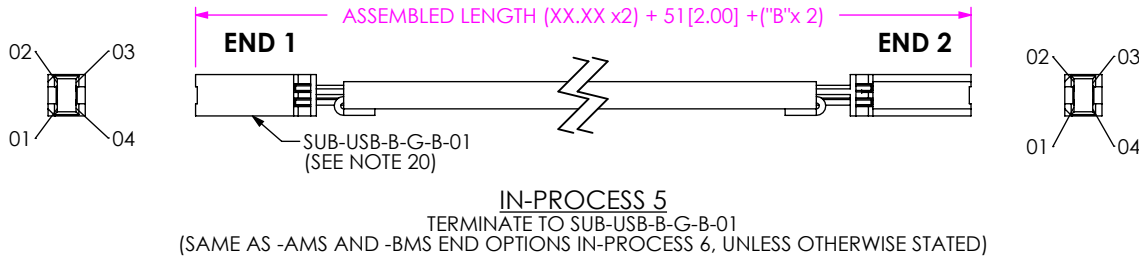

PROPRIETARY NOTE
 THIS DOCUMENT CONTAINS CONFIDENTIAL AND PROPRIETARY INFORMATION AND ALL DESIGN, MANUFACTURING, REPRODUCTION, USE, PATENT RIGHTS AND SALES RIGHTS ARE EXPRESSLY RESERVED BY SAMTEC, INC. THIS DOCUMENT SHALL NOT BE DISCLOSED, IN WHOLE OR PART, TO ANY UNAUTHORIZED PERSON OR ENTITY NOR REPRODUCED, TRANSFERRED OR INCORPORATED IN ANY OTHER PROJECT IN ANY MANNER WITHOUT THE EXPRESS WRITTEN CONSENT OF SAMTEC, INC.

DO NOT SCALE DRAWING
 SHEET SCALE: 3:4



520 PARK EAST BLVD, NEW ALBANY, IN 47150
 PHONE: 812-944-6733 FAX: 812-948-5047
 e-Mail info@SAMTEC.com code 55322

DESCRIPTION:
 SEALED CIRCULAR CABLE PLUG, USB
 DWG. NO.
 SCPU-17-X-XX.XX-XXX-XXX

BY: CHAD F 12/8/2004 SHEET 10 OF 10