

SCALE 1:1

NOTES:
 RATED VOLTAGE: 3 contacts 60V AC/DC
 4 contacts 30V AC/DC
 RATED CURRENT: 3A
 PROTECTION CLASS: IP67
 TEMPERATURE: -25°C / +80°C

CONTACT POSITION FRONT VIEW:

3 POLES (2 WIRES)		3 POLES		4 POLES	
PIN	WIRE	PIN	WIRE	PIN	WIRE
1	BROWN	1	BROWN	1	BROWN
2	---	2	---	2	WHITE
3	BLUE	3	BLUE	3	BLUE
4	N/U	4	BLACK	4	BLACK
5	---	5	---	5	---

TABLE 1

POS	QTY	DESCRIPTION	MATERIAL	FINISH
1	-	CABLE	SEE SHEET 2	SEE SHEET 2
2	3 / 4	CONTACT FEMALE	CuNi2Si	Cu/Ni2
3	-	OVERMOLD	TPU OR PVC	BLACK OR YELLOW
4	1	INSERT FEMALE	ELASTOLLAN	BLACK
5	1	LABEL YELLOW	VINYL	-
	-	PRINTING FOR CABLES I02	-	-

THIS DRAWING CONTAINS INFORMATION THAT IS PROPRIETARY TO MOLEX ELECTRONIC TECHNOLOGIES, LLC AND SHOULD NOT BE USED WITHOUT WRITTEN PERMISSION

EC NO: 118614 DRWN: FGAIK CHK'D: APPR: BBRAUCH	2017/01/09	GENERAL TOLERANCES (UNLESS SPECIFIED) ANGULAR TOL ± 1.0 ° 4 PLACES ± 3 PLACES ± 2 PLACES ± 0.05 1 PLACE ± 0.3 0 PLACES ± 0.5 DRAFT WHERE APPLICABLE MUST REMAIN WITHIN DIMENSIONS	DIMENSION UNITS	SCALE	 CSE M8SNAP XP AC FE RA XM SE UNSH PRODUCT CUSTOMER DRAWING	
	2017/06/27		MM	2:1		
			DRWN BY	DATE		
			FGAIK	2016/05/16		
			CHK'D BY	DATE		
			APPR BY	DATE		
			BBRAUCH	2017/06/27		
			DRAWING SIZE	THIRD ANGLE PROJECTION		
			A3			
			SERIES	MATERIAL NUMBER	CUSTOMER	
			120088	SEE SHEET 2	GENERAL MARKET	
			DOCUMENT NUMBER	DOC TYPE	DOC PART	
			1200888086	PSD	000	
				SHEET NUMBER		
				1 OF 2		

ENGINEERING NO. - NUMERICAL CODE (Available parts see table 2. Other parts available upon request).

OPTIONS

50X001XXXMXXX

50=Snap
Nano Change
Single Ended

Poles:
2=2 Poles
3=3 Poles
4=4 Poles

Heads style:
001=Plug Female
90° Angled

Cable type: See Table 3

Unit:
M=Meter

Length
Examples:
005=0.5 unit
010=1 unit
100=10 units

Overmold color:
Blank (Standard)=Black
Y=Yellow

H= 2 pcs. of I/D Carrier PVC Transparent
(Cables lxx always with
2 pcs. I/D Carrier)



TABLE 2

POS.	MOLEX PN	ENGINEERING NO.	L [mm]
1	1200290006	502001I02M020	2000
2	1200888146	502001I02M020Y	2000
3	1200290007	502001I02M050	5000
4	1200290008	502001I02M100	10000
5	1200888147	502001I02M100Y	10000
6	1200888086	503001E02M020	2000
7	1200888010	503001E02M050	5000
8	1200888064	503001E02M100	10000
9	1200888128	503001H08M020	2000
10	1200888159	503001H08M050	5000
11	1200888184	503001H08M050H	5000
12	1200888152	503001H08M150	15000
13	1200888153	503001H08M200	20000
14	1200888087	503001I02M020	2000
15	1200888088	503001I02M030	3000
16	1200888089	503001I02M100	10000
17	1200888090	503001P02M020	2000
18	1200888091	503001P02M050	5000
19	1200888161	503001P02M100	10000
20	1200888185	503001P02M100H	10000
21	1200888124	504001E02M020	2000
22	1200888100	504001E02M030	3000
23	1200888101	504001E02M100	10000
24	1200888126	504001H08M020	2000
25	1200888149	504001P02M002	200
26	1200888151	504001P02M015	1500
27	1200888125	504001P02M020	2000
28	1200888102	504001P02M030	3000
29	1200888103	504001P02M050	5000

TABLE 3

CABLE TYPE	NO. OF WIRES	CROSS SECTION	CABLE JACKET	UL	CSA	STATIC: TEMP. / BENDING RADIUS	DYNAMIC: TEMP. / BENDING RADIUS	DRAG CHAIN
E02	3 / 4	0.25mm ²	PVC BLACK	UL 1729/2464	C22.2 I/II A/B 80°C 300V	-30°C to +80°C / 10xO.D.	-10°C to +80°C / 15xO.D.	-
H08	3 / 4	0.25mm ²	PUR BLACK LS0H	UL 10493/21198	C22.2 I/II A/B 80°C 300V	-40°C to +80°C / 5xO.D.	-25°C to +80°C / 10xO.D.	2 000 000 cycles, Temp max 60°C
I02	2 / 3 / 4	0.25mm ²	PVC (CEI) GREY	-	-	-30°C to +70°C	-5°C to +70°C	-
P02	3 / 4	0.25mm ²	PUR / PVC BLACK	-	-	-30°C to +80°C / 7xO.D.	-5°C to +80°C / 15xO.D.	-

CABLE LENGTH TOLERANCES

OVER [mm]	UP TO AND INCLUDING [mm]	TOLERANCES [mm]
0	305	+19
305	915	+45
915	1830	+56
1830	3660	+89
3660	7320	+165
7320	14640	+317
14640	30500	+610
30500	>	+2% of finished length

THIS DRAWING CONTAINS INFORMATION THAT IS PROPRIETARY TO MOLEX ELECTRONIC TECHNOLOGIES, LLC AND SHOULD NOT BE USED WITHOUT WRITTEN PERMISSION

2017/01/09 2017/06/27	2017/06/27	GENERAL TOLERANCES (UNLESS SPECIFIED)	DIMENSION UNITS	SCALE	molex [®]			
		ANGULAR TOL ± 1.0 °	MM	1:1				
		4 PLACES ±	DRWN BY	DATE				
		3 PLACES ±	FGAIK	2016/05/16				
EC NO: 118614 DRWN: FGAIK CHK'D: BBRAUCH REVISION: 0 DATE: 2015/12/14	2017/06/27	2 PLACES ± 0.05	CHK'D BY	DATE	CSE M8SNAP XP AC FE RA XM SE UNSH			
		1 PLACE ± 0.3	APPR BY	DATE				
		0 PLACES ± 0.5	BBRAUCH	2017/06/27				
		DRAFT WHERE APPLICABLE MUST REMAIN WITHIN DIMENSIONS	DRAWING SIZE	THIRD ANGLE PROJECTION				
A	REV	A3			PRODUCT CUSTOMER DRAWING			
					SERIES	MATERIAL NUMBER	CUSTOMER	
					120088	SEE TABLE 2	GENERAL MARKET	
					DOCUMENT NUMBER	DOC TYPE	DOC PART	SHEET NUMBER
					1200888086	PSD	000	2 OF 2

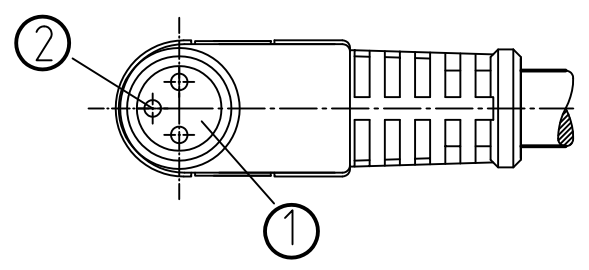
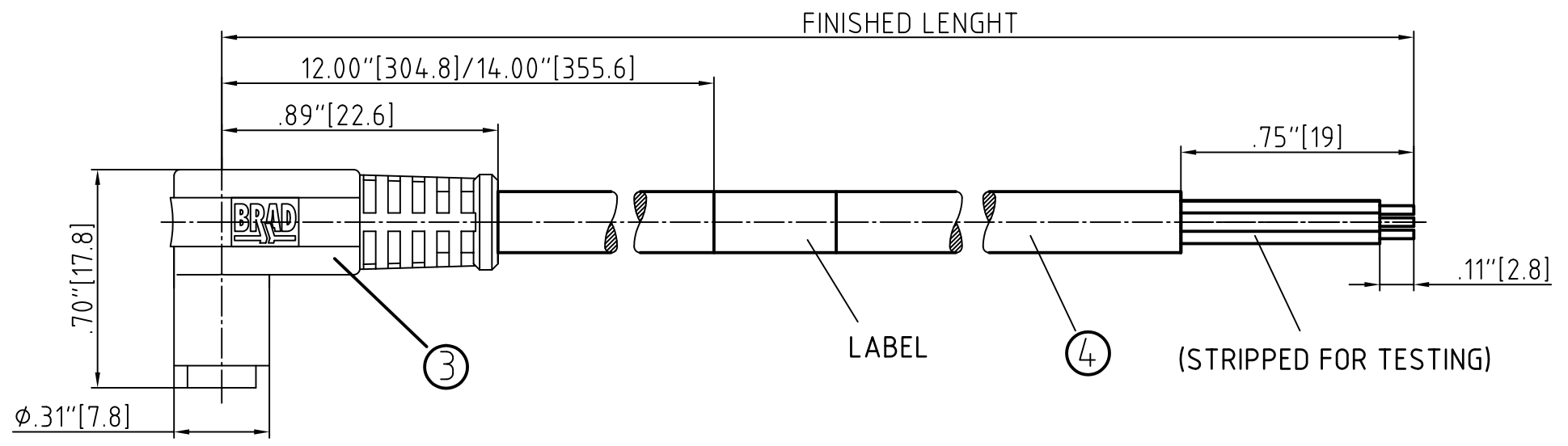

FEMALE FACE VIEW	
3-POLE	4-POLE
1 BROWN 3 BLUE 4 BLACK	1 BROWN 2 WHITE 3 BLUE 4 BLACK

POLE	MATERIAL NUMBER	ENGINEERING NUMBER	FINISHED LENGHT
4	1200888035	504-001E02M050	16.40' +6.50" -0 [5.0M +165.1 -0]

CONNECTOR SPECIFICATION:	
VOLTAGE RATING	3-4POL:60V/AC 75V/DC
AMPERAGE RATING	3 AMPS
PROTECTION	IP65
OPERATING TEMPERATURE	-30°C TO +80°C (STATIC)
UL CERTIFICATIONS	UL listed, File #E152210
CSA CERTIFICATIONS	CSA CERTIFIED, File LR6837

ITEM	COMPONENT	MATERIAL	FINISH
1	INSERT	POLYURETHANE (PUR)	BLACK
2	CONTACT SOCKET	COPPER ALLOY	GOLD OVER NICKEL
3	OVERMOLD	PVC	YELLOW
4	CABLE 4x0.25mm ² (24AWG) (COPPER STRANDING) 4 CONDUCT. 300V	JACKET: PVC	BLACK

DESCRIPTION EC NO.: WEU2010-0305 DRWN: REISSNER 2010/01/27 CH'KD: FP APPR: NSTAUDIG 2010/02/01	QUALITY SYMBOLS ▽ = 0 ▽/C = 0	GENERAL TOLERANCES (UNLESS SPECIFIED) mm INCH 4 PLACES ±--- ±--- 3 PLACES ±--- ±--- 2 PLACES ±--- ±.01 1 PLACE ±0.3 ±--- ANGULAR ± --- °	DIMENSION STYLE IN/MM DRAWN BY DATE REISSNER 2010/01/27 CHECKED BY DATE FP 2010/01/27 APPROVED BY DATE NSTAUDIG 2010/02/01	SCALE 2:1 DESIGN UNITS METRIC THIRD ANGLE PROJECTION
	DRAFT WHERE APPLICABLE MUST REMAIN WITHIN DIMENSIONS		SEE TABLE	NC 3/4P FE 90 SNAP 24AWG PVC ----
	SIZE A3		THIS DRAWING CONTAINS INFORMATION THAT IS PROPRIETARY TO MOLEX INCORPORATED AND SHOULD NOT BE USED WITHOUT WRITTEN PERMISSION	
	MOLEX INCORPORATED SD-120088-013		SHEET NO. 1	