

DO NOT SCALE FROM THIS PRINT

TABLE 1				
No OF POS	"A"	"D"	N	N-1
-02	1.000 [.0394]	9.10 [.358]	04	03
-03	2.000 [.0787]	10.10 [.398]	06	05
-04	3.000 [.1181]	11.10 [.437]	08	07
-05	4.000 [.1575]	12.10 [.476]	10	09
-06	5.000 [.1969]	13.10 [.516]	12	11
-07	6.000 [.2362]	14.10 [.555]	14	13
-08	7.000 [.2756]	15.10 [.594]	16	15
-09	8.000 [.3150]	16.10 [.634]	18	17
-10	9.000 [.3543]	17.10 [.673]	20	19
*-11	10.000 [.3937]	18.10 [.713]	22	21
*-12	11.000 [.4331]	19.10 [.752]	24	23
*-13	12.000 [.4724]	20.10 [.791]	26	25
*-14	13.000 [.5118]	21.10 [.831]	28	27
*-15	14.000 [.5512]	22.10 [.870]	30	29
*-16	15.000 [.5906]	23.10 [.909]	32	31
*-17	16.000 [.6299]	24.10 [.949]	34	33
*-18	17.000 [.6693]	25.10 [.988]	36	35
*-19	18.000 [.7087]	26.10 [1.028]	38	37
*-20	19.000 [.7480]	27.10 [1.067]	40	39

(\* = NOT TOOLED)

**DESIGNED & DIMENSIONED IN MILLIMETERS[INCHES] ALL DIMENSION REFERENCE**

T1XDX-XX-XXX-XX-XX.X-X-XX

**PANEL**  
 -P: PANEL MOUNT  
 -S: NON-PANEL MOUNT

**FEP CABLE OPTION**  
 -T: FEP INSULATION  
 LEAVE BLANK FOR PVC (SEE NOTE 7)

**No OF POSITIONS**  
 -02 THRU -10  
 \*-11 THRU \*-20 (PER ROW)

**WIRE GAUGE (AWG)**  
 -28, -30

**COLOR CODE**  
 -C: COLOR CODE WIRE (SEE TABLE 2, SHT 2)  
 (LEAVE BLANK FOR STANDARD WIRE)  
 (NOT AVAILABLE WITH FEP OPTION)

**PINOUT**  
 (LEAVE BLANK FOR SINGLE END ASSEMBLY)  
 \*\*-D1: DOUBLE ENDED DOWN  
 \*\*-D3: DOUBLE ENDED UP  
 -T1: TRANSFER TO SOCKET DOWN  
 -T3: TRANSFER TO SOCKET UP

**PANEL OPTION**  
 (LEAVE BLANK FOR NON-PANEL MOUNT)  
 A: FITS 0.84, 1.57, & 2.29 THICK PANELS

**ASSEMBLED LENGTH**  
 (SPECIFY IN INCHES) 01.8 IN MINIMUM

**PLATING SPECIFICATION**  
 -GF: 3μ" GOLD CONTACT AND TAIL

\*= NOT TOOLED  
 \*\* = NOT AVAILABLE FOR -P OPTION

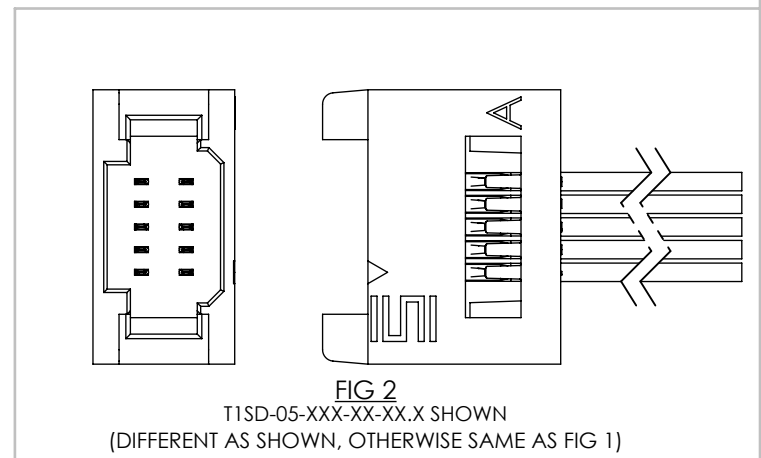
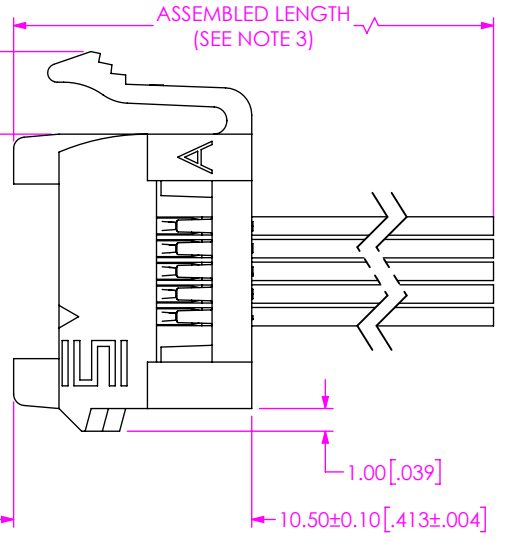
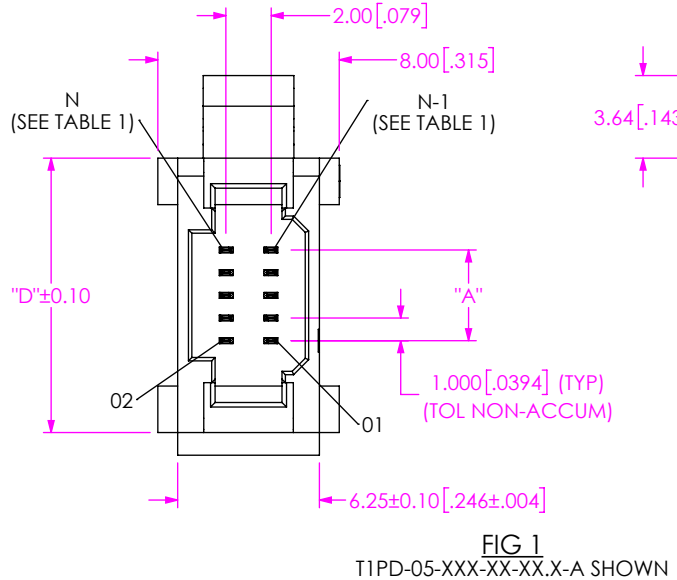

- NOTES:
1. NOTED DELETED.
  2. PARTS TO BE PACKAGED IN BAG.
  3. FOR ASSEMBLED LENGTHS LESS THAN 13.00 IN, TOLERANCE SHALL BE ± 3.18[.125], FOR OTHER LENGTHS, TOLERANCE SHALL BE ± 2%.
  4. NOTE DELETED.
  5. NOTE DELETED.
  6. ALL FINISHED GOODS ARE TO BE ELECTRICALLY TESTED INCLUDING HI-POT TEST AT 1000 VOLTS DC. AFTER FINAL ELECTRICAL TEST, LABEL WITH 1 ET STAMP ON THE BODY.
  7. ASSEMBLIES USING THE FEP OPTION ARE FOR CRIMP APPLICATIONS ONLY.
  8. CUT LENGTH IS ASSEMBLY LENGTH MINUS OVERALL LENGTH SUBTRACTOR.

UNLESS OTHERWISE SPECIFIED, DIMENSIONS ARE IN INCHES. TOLERANCES ARE: DECIMALS            ANGLES .XX: ±.01[0.3] .XXX: ±.005[0.13] .XXXX: ±.0020[0.051]	* PROPRIETARY NOTE * THIS DOCUMENT CONTAINS CONFIDENTIAL AND PROPRIETARY INFORMATION AND ALL DESIGN, MANUFACTURING, REPRODUCTION, USE, PATENT RIGHTS AND SALES RIGHTS ARE EXPRESSLY RESERVED BY SAMTEC, INC. THIS DOCUMENT SHALL NOT BE DISCLOSED, IN WHOLE OR PART, TO ANY UNAUTHORIZED PERSON OR ENTITY NOR REPRODUCED, TRANSFERRED OR INCORPORATED IN ANY OTHER PROJECT IN ANY MANNER WITHOUT THE EXPRESS WRITTEN CONSENT OF SAMTEC, INC.	 520 PARK EAST BLVD, NEW ALBANY, IN 47150 PHONE: 812-944-6733    FAX: 812-948-5047 e-Mail: info@SAMTEC.com    code 53322

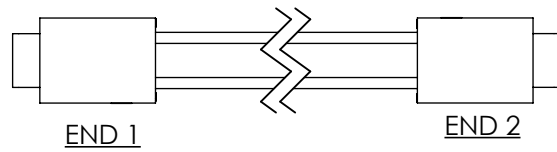

(SEE TABLE 1, SHT 1)

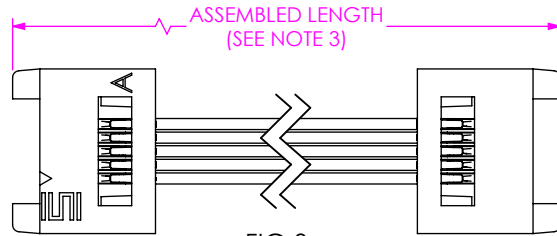
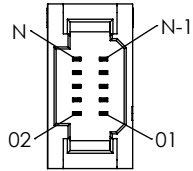

(SEE TABLE 1, SHT 1)

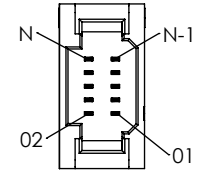
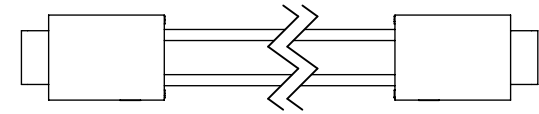

FIG 3

T1SD-05-XXX-XX-XX.X-D1 SHOWN  
(DIFFERENT AS SHOWN, OTHERWISE SAME AS FIG 2)



(SEE TABLE 1, SHT 1)

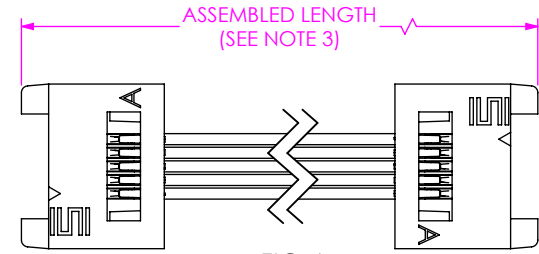
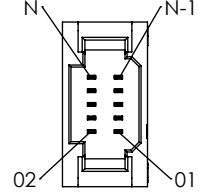
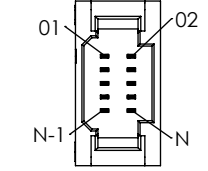
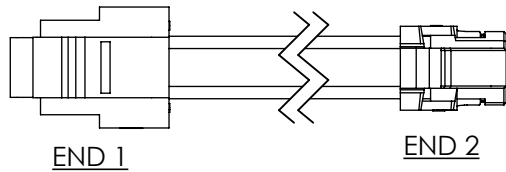

FIG 4

T1SD-05-XXX-XX-XX.X-D3 SHOWN  
(DIFFERENT AS SHOWN, OTHERWISE SAME AS FIG 2)



(SEE TABLE 1, SHT 1)



(SEE TABLE 1, SHT 1)

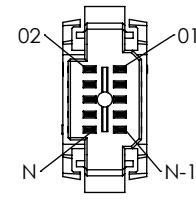
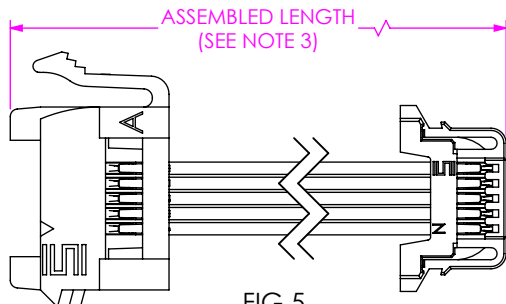
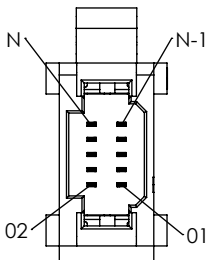

(SEE TABLE 1, SHT 1)

FIG 5

T1PD-05-XXX-XX-XX.X-A-T1 SHOWN  
(DIFFERENT AS SHOWN, OTHERWISE SAME AS FIG 1)

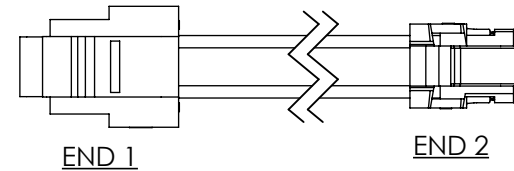

(SEE TABLE 1, SHT 1)

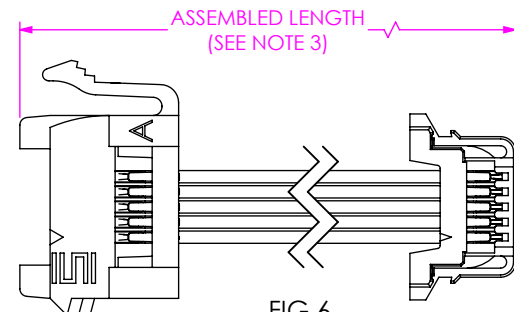
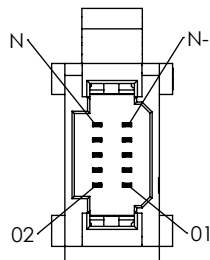

FIG 6

T1PD-05-XXX-XX-XX.X-A-T3 SHOWN  
(DIFFERENT AS SHOWN, OTHERWISE SAME AS FIG 1 & FIG 5)

(SEE TABLE 1, SHT 1)

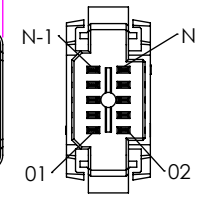

TABLE 2

T1XDX COLOR CODED WIRE SEQUENCE

PIN#	COLOR									
	BROWN	RED	ORANGE	YELLOW	GREEN	BLUE	VIOLET	GRAY	WHITE	BLACK
	1	2	3	4	5	6	7	8	9	10
	11	12	13	14	15	16	17	18	19	20
	21	22	23	24	25	26	27	28	29	30
	31	32	33	34	35	36	37	38	39	40

**PROPRIETARY NOTE**  
THIS DOCUMENT CONTAINS CONFIDENTIAL AND PROPRIETARY INFORMATION AND ALL DESIGN, MANUFACTURING, REPRODUCTION, USE, PATENT RIGHTS AND SALES RIGHTS ARE EXPRESSLY RESERVED BY SAMTEC, INC. THIS DOCUMENT SHALL NOT BE DISCLOSED, IN WHOLE OR PART, TO ANY UNAUTHORIZED PERSON OR ENTITY NOR REPRODUCED, TRANSFERRED OR INCORPORATED IN ANY OTHER PROJECT IN ANY MANNER WITHOUT THE EXPRESS WRITTEN CONSENT OF SAMTEC, INC.



520 PARK EAST BLVD, NEW ALBANY, IN 47150  
PHONE: 812-944-6733 FAX: 812-948-5047  
e-Mail info@SAMTEC.com code 55322

DO NOT SCALE DRAWING

SHEET SCALE: 2:1

DESCRIPTION:  
**1MM T1XDX CABLE ASSEMBLY**

DWG. NO.  
**T1XDX-XX-XXX-XX-XX.X-X-XX**

BY: JERRY SU 03/05/2018 SHEET 2 OF 3

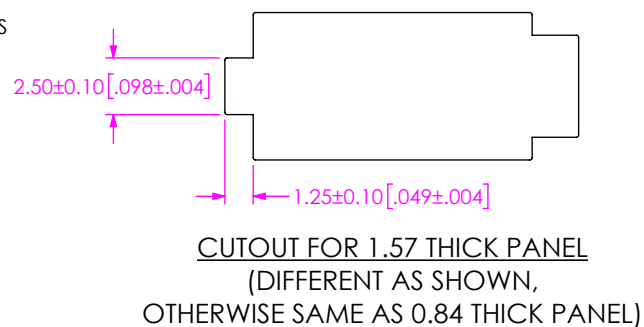
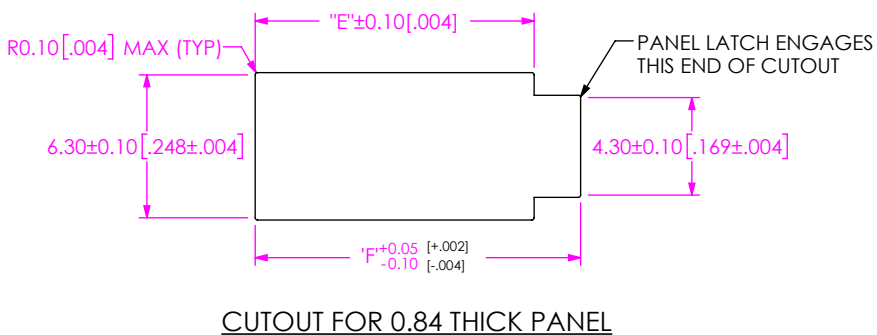
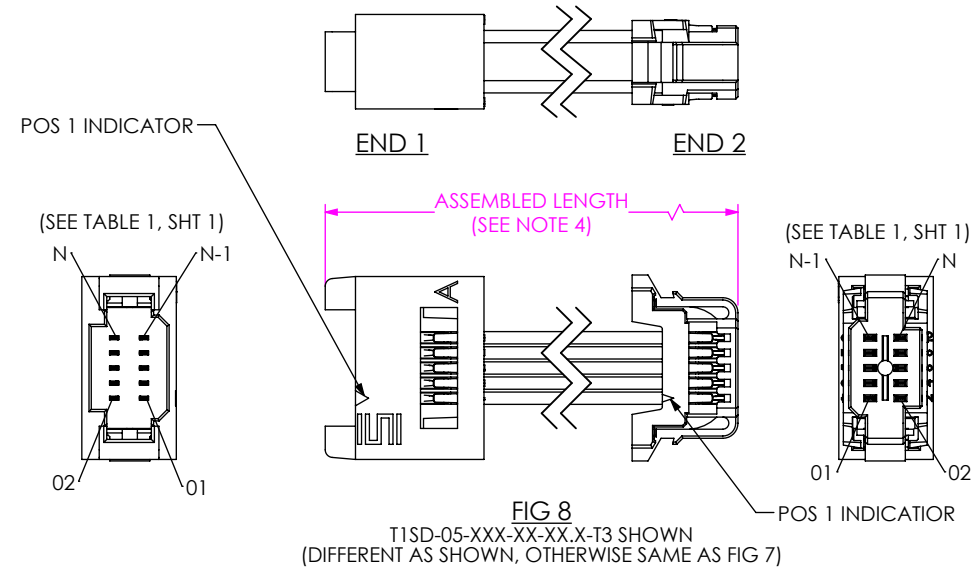
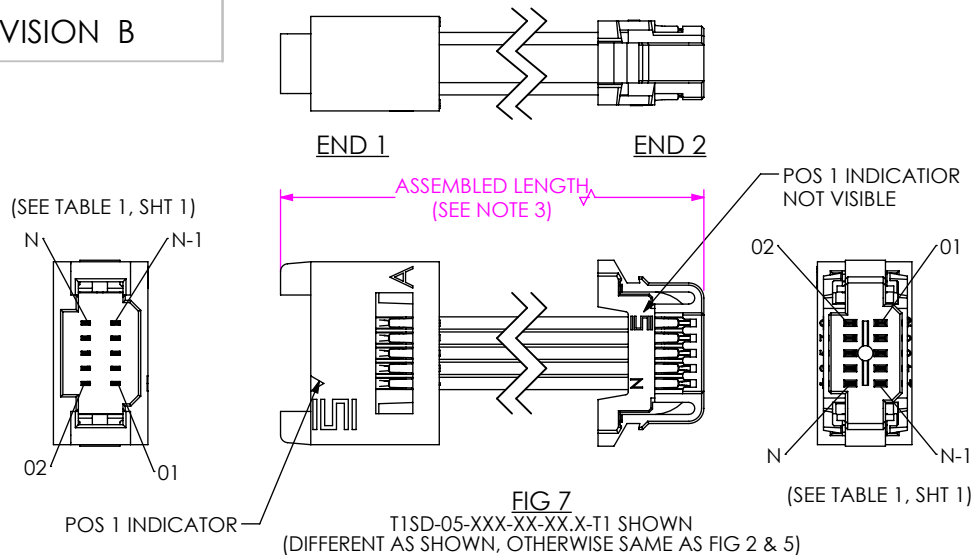

**TABLE 5**

NO OF POS	"E"	"F"
-03	10.30 [0.406]	12.35 [0.486]
-04	11.30 [0.445]	13.35 [0.526]
-05	12.30 [0.484]	14.35 [0.565]
-06	13.30 [0.524]	15.35 [0.604]
-07	14.30 [0.563]	16.35 [0.644]
-08	15.30 [0.602]	17.35 [0.683]
-09	16.30 [0.642]	18.35 [0.722]
-10	17.30 [0.681]	19.35 [0.762]
*-11	18.30 [0.720]	20.35 [0.801]
*-12	19.30 [0.760]	21.35 [0.841]
*-13	20.30 [0.799]	22.35 [0.880]
*-14	21.30 [0.839]	23.35 [0.919]
*-15	22.30 [0.878]	24.35 [0.959]
*-16	23.30 [0.917]	25.35 [0.998]
*-17	24.30 [0.957]	26.35 [1.037]
*-18	25.30 [0.996]	27.35 [1.077]
*-19	26.30 [1.035]	28.35 [1.116]
*-20	27.30 [1.075]	29.35 [1.156]

(\* = NOT TOOLED)

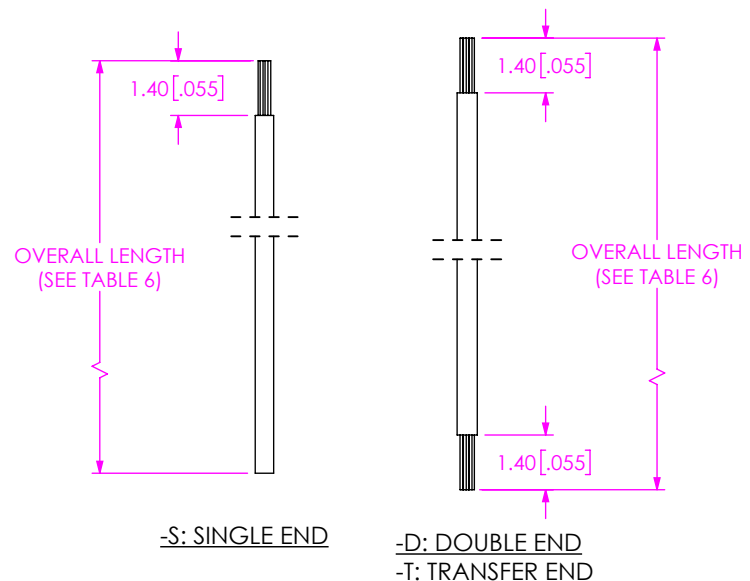

**TABLE 6  
( OVERALL LENGTH SUBTRACTORS )  
(SEE NOTE 8)**

	LENGTH
-S: SINGLE END	8.03 [0.316]
-D: DOUBLE END	16.06 [0.632]
-T: TRANSFER END	10.82 [0.426]

F:\DWG\MISC\MKTG\T1XDX-XX-XXX-XX-XX.X-X-XX-MKT.SLDDRW

**PROPRIETARY NOTE**  
THIS DOCUMENT CONTAINS CONFIDENTIAL AND PROPRIETARY INFORMATION AND ALL DESIGN, MANUFACTURING, REPRODUCTION, USE, PATENT RIGHTS AND SALES RIGHTS ARE EXPRESSLY RESERVED BY SAMTEC, INC. THIS DOCUMENT SHALL NOT BE DISCLOSED, IN WHOLE OR PART, TO ANY UNAUTHORIZED PERSON OR ENTITY NOR REPRODUCED, TRANSFERRED OR INCORPORATED IN ANY OTHER PROJECT IN ANY MANNER WITHOUT THE EXPRESS WRITTEN CONSENT OF SAMTEC, INC.

DO NOT SCALE DRAWING  
SHEET SCALE: 2:1

520 PARK EAST BLVD, NEW ALBANY, IN 47150  
PHONE: 812-944-6733 FAX: 812-948-5047  
e-Mail info@SAMTEC.com code 55322

DESCRIPTION:  
1MM T1XDX CABLE ASSEMBLY

DWG. NO.  
T1XDX-XX-XXX-XX-XX.X-X-XX

BY: JERRY SU 03/05/2018 SHEET 3 OF 3