

DO NOT
SCALE FROM
THIS PRINT

DOUBLE ROW

No OF POSITIONS
(PER ROW)

-05
-10
-15
-20

WIRE GAUGE
-32: FEP
(SEE NOTE 9)

PLATING SPECIFICATION

-G: 10µ" GOLD IN CONTACT AREA,
3µ" GOLD ON TAIL

ASSEMBLED LENGTH
SPECIFY IN INCHES
(03.0 INCH MINIMUM)

PINOUT

(LEAVE BLANK FOR SINGLE END ASSEMBLY)

- 1: KEY DOWN, CROSSED (PIN 01 TO 01, SEE FIG 3, SHT 2)
- 2: KEY DOWN, STRAIGHT (PIN 01 TO 02, SEE FIG 4, SHT 2)
- 3: KEY UP, STRAIGHT (PIN 01 TO N-1, SEE FIG 5, SHT 3)
- 4: KEY UP, CROSSED (PIN 01 TO N, SEE FIG 6, SHT 3)

LATCH OPTION

-L: PLASTIC LATCH

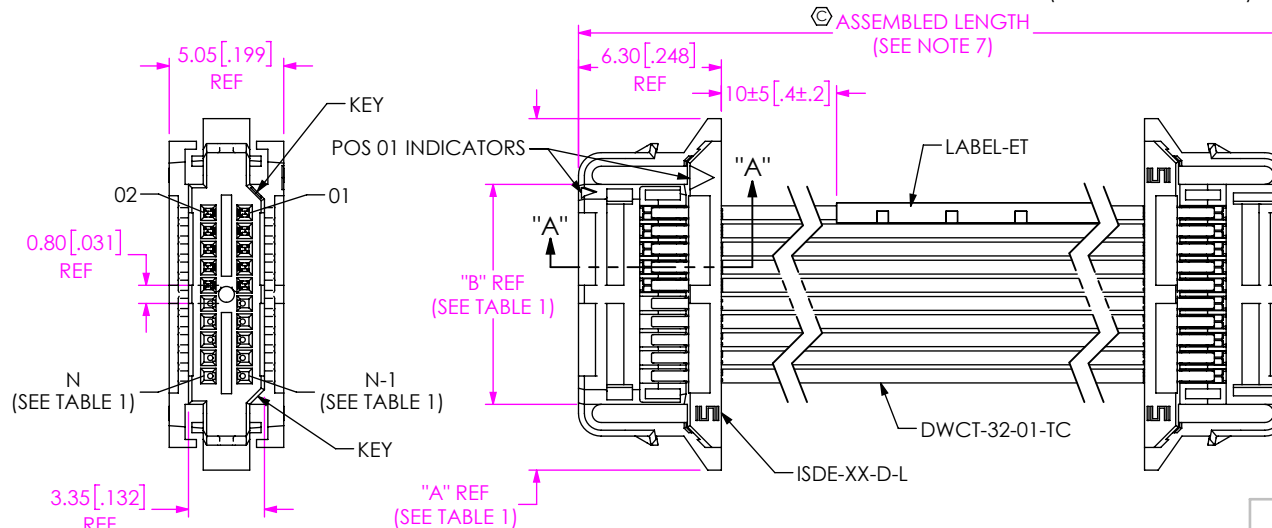
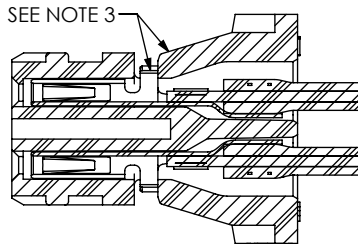

FIG 1
SESDT-10-32-X-XX.X-L2 SHOWN



SECTION "A"-"A"
SCALE 6 : 1

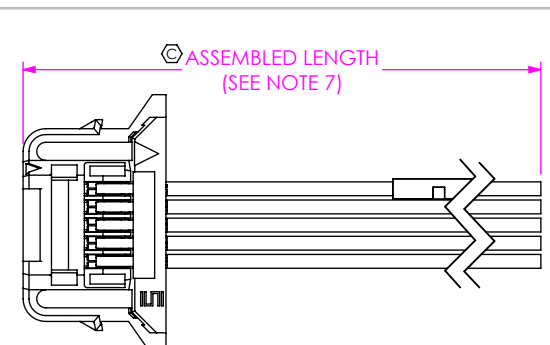
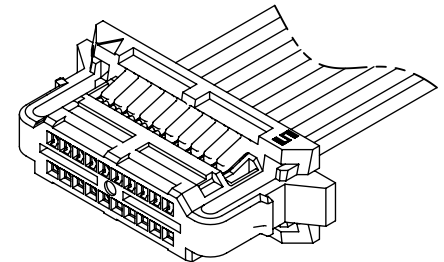

FIG 2
SESDT-05-32-X-XX.X-L SHOWN
(BUILD DOUBLE ENDED INITIALLY FOR E-TEST)

TABLE 1					
No OF POSITIONS	N	N-1	"A"	"B"	
-05	10	09	11.50 [0.453]	5.70 [0.224]	
-10	20	19	15.50 [0.610]	9.70 [0.382]	
-15	30	29	19.50 [0.768]	13.70 [0.539]	
-20	40	39	23.50 [0.925]	17.70 [0.697]	

NOTES:

1. Ⓞ REPRESENTS A CRITICAL DIMENSION.
2. MINIMUM PULLOUT FORCE: X.XN [X.X LBS].
- Ⓞ 3. CONTACTS MUST BE INSERTED UNTIL RETENTION FEATURES LOCK INTO PLACE.
- Ⓞ 4. ALL FINISHED GOODS ARE TO BE ELECTRICALLY TESTED INCLUDING HI-POT TEST AT 500 VOLTS DC. AFTER FINAL ELECTRICAL TEST, LABEL EACH ASSEMBLY WITH (1) LABEL-ET.
5. TINNED COPPER WIRE IS RoHS COMPLIANT.
6. PARTS TO BE LAYERED PACKAGED.
7. FOR LENGTHS OF 305 [12.0] AND LESS, TOLERANCE TO BE ±3.18 [0.125], FOR LENGTHS GREATER THAN 305 [12.0], TOLERANCE TO BE ±2%.
8. REFER TO CRIMP SPECIFICATIONS PRINT FOR STRIP AND CRIMP DIMENSIONS, TOLERANCES, TOOLING, AND ITS REQUIREMENTS.
9. ASSEMBLIES USING THE FEP CABLE ARE FOR CRIMP APPLICATIONS ONLY.
10. CUT LENGTH IS ASSEMBLY LENGTH MINUS OVERALL LENGTH SUBTRACTOR.

UNLESS OTHERWISE SPECIFIED,
DIMENSIONS ARE IN MILLIMETERS.

TOLERANCES ARE:
DECIMALS ANGLES
X.X: ±0.3 [0.1] 2°
X.XX: ±0.13 [0.05]
X.XXX: ±0.051 [0.020]

PROPRIETARY NOTE

THIS DOCUMENT CONTAINS CONFIDENTIAL AND PROPRIETARY INFORMATION AND ALL DESIGN, MANUFACTURING, REPRODUCTION, USE, PATENT RIGHTS AND SALES RIGHTS ARE EXPRESSLY RESERVED BY SAMTEC, INC. THIS DOCUMENT SHALL NOT BE DISCLOSED, IN WHOLE OR PART, TO ANY UNAUTHORIZED PERSON OR ENTITY NOR REPRODUCED, TRANSFERRED OR INCORPORATED IN ANY OTHER PROJECT IN ANY MANNER WITHOUT THE EXPRESS WRITTEN CONSENT OF SAMTEC, INC.

MATERIAL: DO NOT SCALE DRAWING SHEET SCALE: 3:1
INSULATOR: NYLON UL94V-0, COLOR: NATURAL
CONTACT: BeCu
WIRE INSULATION: FEP
WIRE: TINNED COPPER



520 PARK EAST BLVD, NEW ALBANY, IN 47150
PHONE: 812-944-6733 FAX: 812-948-5047
e-Mail: info@SAMTEC.com code 53322

DESCRIPTION:
0.80 mm SOCKET DISCRETE WIRE ASSEMBLY

DWG. NO.
SESDT-XX-XX-X-XX.X-LX

BY: J. BORGELT 7/18/2013 SHEET 1 OF 4

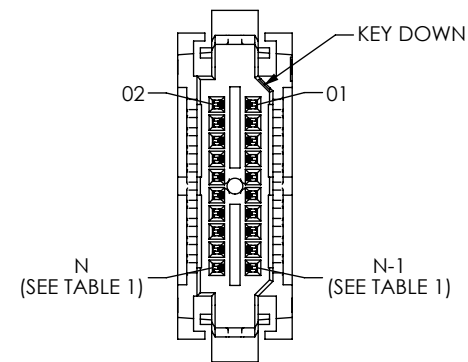
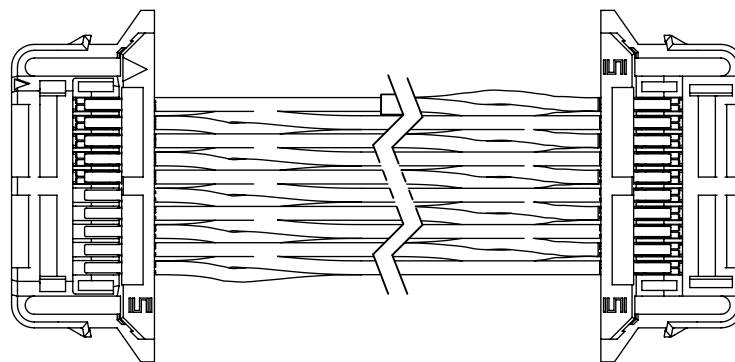
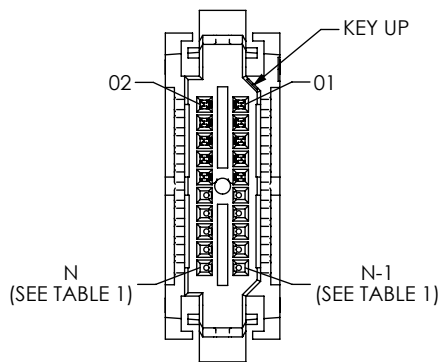

FIG 3
 SESDT-10-32-X-XX.X-L1 SHOWN
 (SAME AS FIG 1, EXCEPT AS SHOWN)
 (PIN 01 TO 01)

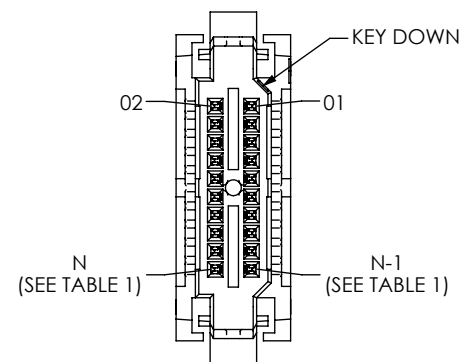
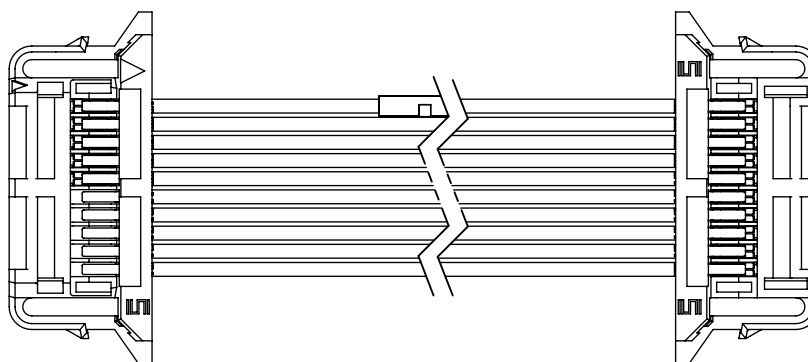
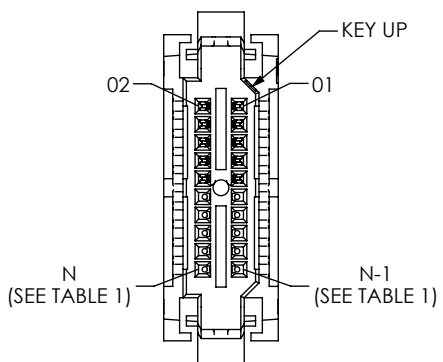

FIG 4
 SESDT-10-32-X-XX.X-L2 SHOWN
 (SAME AS FIG 1, EXCEPT AS SHOWN)
 (PIN 01 TO 02)

PROPRIETARY NOTE
 THIS DOCUMENT CONTAINS CONFIDENTIAL AND PROPRIETARY INFORMATION AND ALL DESIGN, MANUFACTURING, REPRODUCTION, USE, PATENT RIGHTS AND SALES RIGHTS ARE EXPRESSLY RESERVED BY SAMTEC, INC. THIS DOCUMENT SHALL NOT BE DISCLOSED, IN WHOLE OR PART, TO ANY UNAUTHORIZED PERSON OR ENTITY NOR REPRODUCED, TRANSFERRED OR INCORPORATED IN ANY OTHER PROJECT IN ANY MANNER WITHOUT THE EXPRESS WRITTEN CONSENT OF SAMTEC, INC.

samtec
 520 PARK EAST BLVD, NEW ALBANY, IN 47150
 PHONE: 812-944-6733 FAX: 812-948-5047
 e-Mail info@SAMTEC.com code 55322

DO NOT SCALE DRAWING
 SHEET SCALE: 3:1

DESCRIPTION:
 0.80 mm SOCKET DISCRETE WIRE ASSEMBLY
 DWG. NO.
SESDT-XX-XX-X-XX.X-LX
 BY: J. BORGELT 7/18/2013 SHEET 2 OF 4

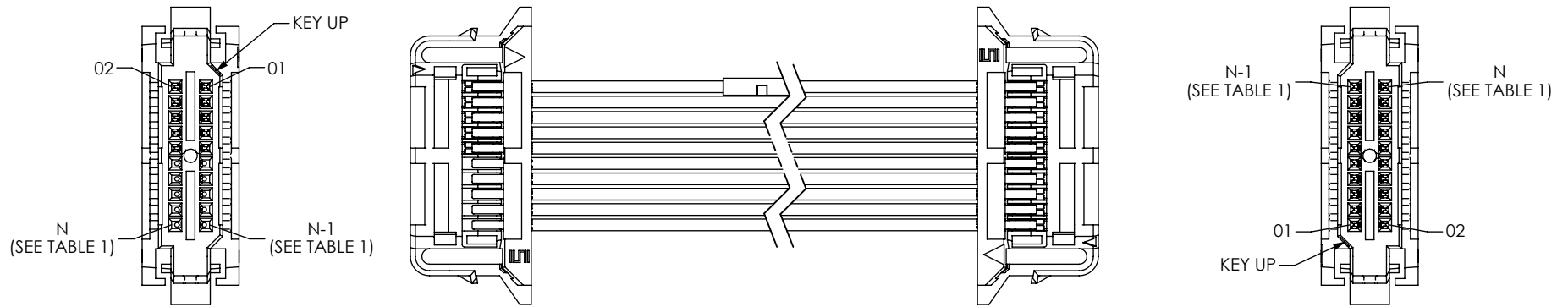

FIG 5
 SESDT-10-32-X-XX.X-L3 SHOWN
 (SAME AS FIG 1, EXCEPT AS SHOWN)
 (PIN 01 TO N-1)

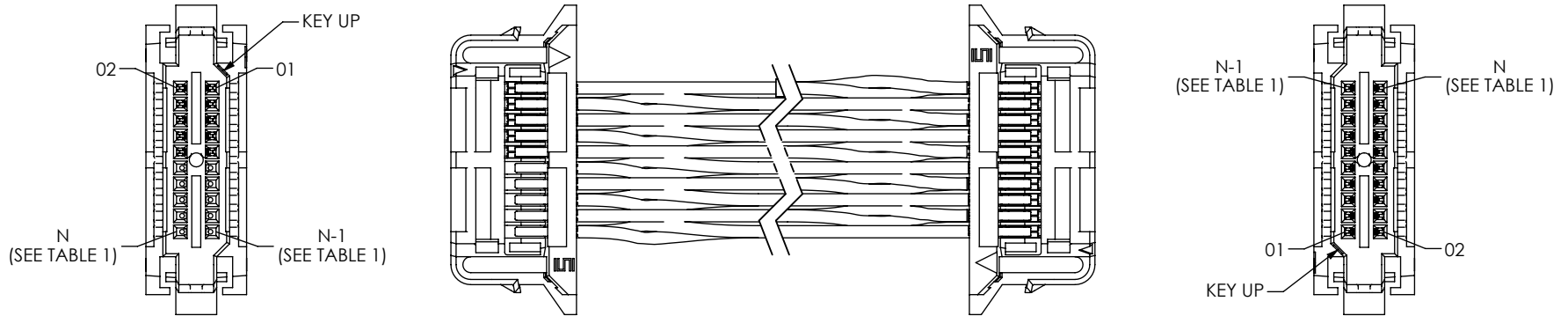

FIG 6
 SESDT-10-32-X-XX.X-L4 SHOWN
 (SAME AS FIG 1, EXCEPT AS SHOWN)
 (PIN 01 TO N)

PROPRIETARY NOTE
 THIS DOCUMENT CONTAINS CONFIDENTIAL AND PROPRIETARY INFORMATION AND ALL DESIGN, MANUFACTURING, REPRODUCTION, USE, PATENT RIGHTS AND SALES RIGHTS ARE EXPRESSLY RESERVED BY SAMTEC, INC. THIS DOCUMENT SHALL NOT BE DISCLOSED, IN WHOLE OR PART, TO ANY UNAUTHORIZED PERSON OR ENTITY NOR REPRODUCED, TRANSFERRED OR INCORPORATED IN ANY OTHER PROJECT IN ANY MANNER WITHOUT THE EXPRESS WRITTEN CONSENT OF SAMTEC, INC.



520 PARK EAST BLVD, NEW ALBANY, IN 47150
 PHONE: 812-944-6733 FAX: 812-948-5047
 e-Mail info@SAMTEC.com code 55322

DO NOT SCALE DRAWING

SHEET SCALE: 3:1

DESCRIPTION:
 0.80 mm SOCKET DISCRETE WIRE ASSEMBLY

DWG. NO.
SESDT-XX-XX-X-XX.X-LX

BY: J. BORGELT 7/18/2013 SHEET 3 OF 4

TABLE 2: OVERALL LENGTH SUBTRACTORS (SEE NOTE 10)		
SERIES	"C"	"D"
SESDT	0.130	0.259

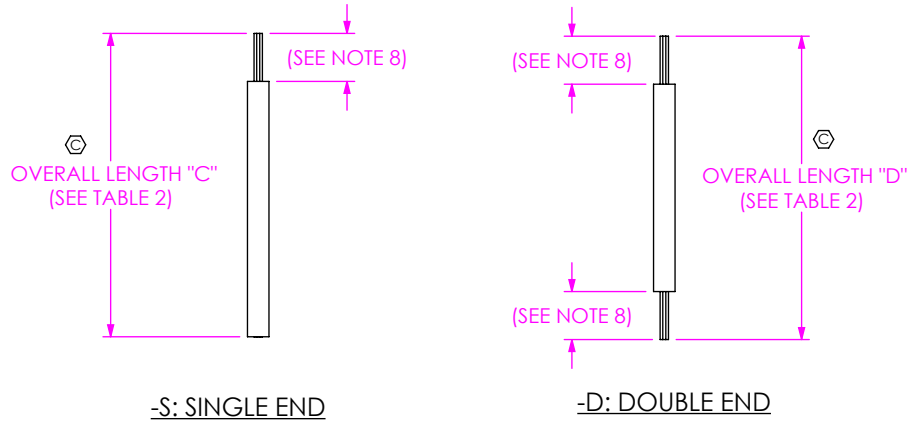

IN-PROCESS 1
CUT WIRE TO LENGTH

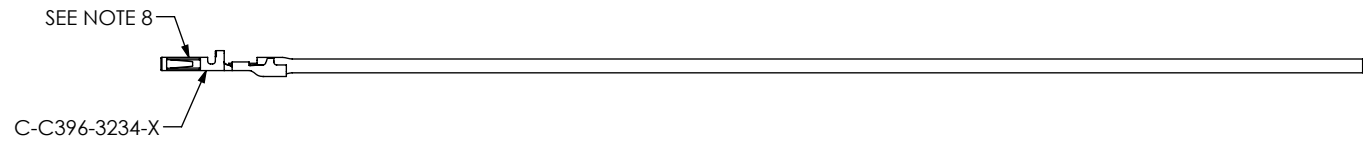

IN-PROCESS 2
CRIMP CONTACT

<p>PROPRIETARY NOTE</p> <p>THIS DOCUMENT CONTAINS CONFIDENTIAL AND PROPRIETARY INFORMATION AND ALL DESIGN, MANUFACTURING, REPRODUCTION, USE, PATENT RIGHTS AND SALES RIGHTS ARE EXPRESSLY RESERVED BY SAMTEC, INC. THIS DOCUMENT SHALL NOT BE DISCLOSED, IN WHOLE OR PART, TO ANY UNAUTHORIZED PERSON OR ENTITY NOR REPRODUCED, TRANSFERRED OR INCORPORATED IN ANY OTHER PROJECT IN ANY MANNER WITHOUT THE EXPRESS WRITTEN CONSENT OF SAMTEC, INC.</p>	 <p>520 PARK EAST BLVD. NEW ALBANY, IN 47150 PHONE: 812-944-6733 FAX: 812-948-5047 e-Mail info@SAMTEC.com code 55322</p>	
	<p>DO NOT SCALE DRAWING</p> <p>SHEET SCALE: 3:1</p>	<p>DESCRIPTION: 0.80 mm SOCKET DISCRETE WIRE ASSEMBLY</p> <p>DWG. NO. SESDT-XX-XX-X-XX.X-LX</p> <p>BY: J. BORGELT 7/18/2013 SHEET 4 OF 4</p>