

CATALOG NUMBER	MATERIAL NUMBER	CONDUIT SIZE	N.P.T. FITTING SIZE	LENGTH "M"	DIAMETER "A" REF.	LENGTH "B" REF.	LENGTH "C" REF.	LENGTH "D" REF.	PRODUCT SELECTION NUMBER
36443	1300960058	3/8"	1/2"	3.875±0.500 / 98.43±12.70	1.0 / 25	1.13 / 28.7	0.63 / 16.0	1.25 / 31.8	STB038P-90
36400	1300960050	1/2"	1/2"	4.625±0.500 / 117.48±12.70	1.2 / 30	1.25 / 31.8	0.63 / 16.0	1.25 / 31.8	STB050P-90
36402	1300960052	1"	1"	7.000±0.500 / 177.80±12.70	1.7 / 43	1.81 / 45.9	0.75 / 19.1	1.38 / 35.1	STB100P-90
36403	1300960053	1-1/4"	1-1/4"	8.125±1.000 / 206.38±25.40	2.0 / 51	2.31 / 58.7	0.63 / 16.0	1.81 / 45.9	STB125P-90
36404	1300960054	1-1/2"	1-1/2"	9.250±1.000 / 234.95±25.40	2.5 / 64	2.63 / 66.8	0.63 / 16.0	2.44 / 61.9	STB150P-90
36405	1300960055	2"	2"	11.500±1.000 / 292.10±25.40	3.0 / 76	3.19 / 81.0	0.69 / 17.5	2.63 / 66.8	STB200P-90
37033	-----	2-1/2"	2-1/2"	11.250±1.000 / 285.75±25.40	3.6 / 91	3.94 / 100.1	1.06 / 26.9	7.19 / 182.6	STB250P-90
37034	-----	3"	3"	14.750±1.500 / 374.65±38.10	4.3 / 109	4.38 / 111.3	1.19 / 30.2	8.63 / 219.2	STB300P-90
37035	-----	4"	4"	16.250±1.500 / 412.75±38.10	5.4 / 137	5.50 / 139.7	1.25 / 31.8	11.25 / 285.8	STB400P-90

UL LISTED	CSA APRVD
YES	YES

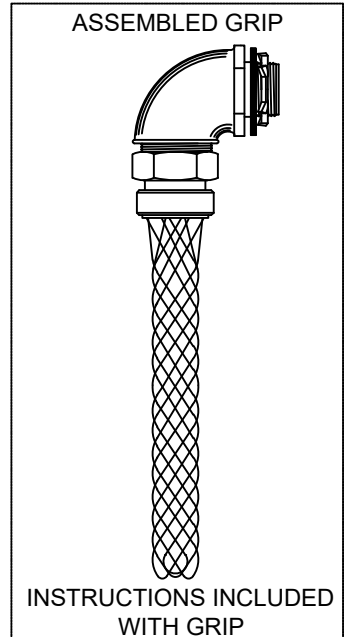
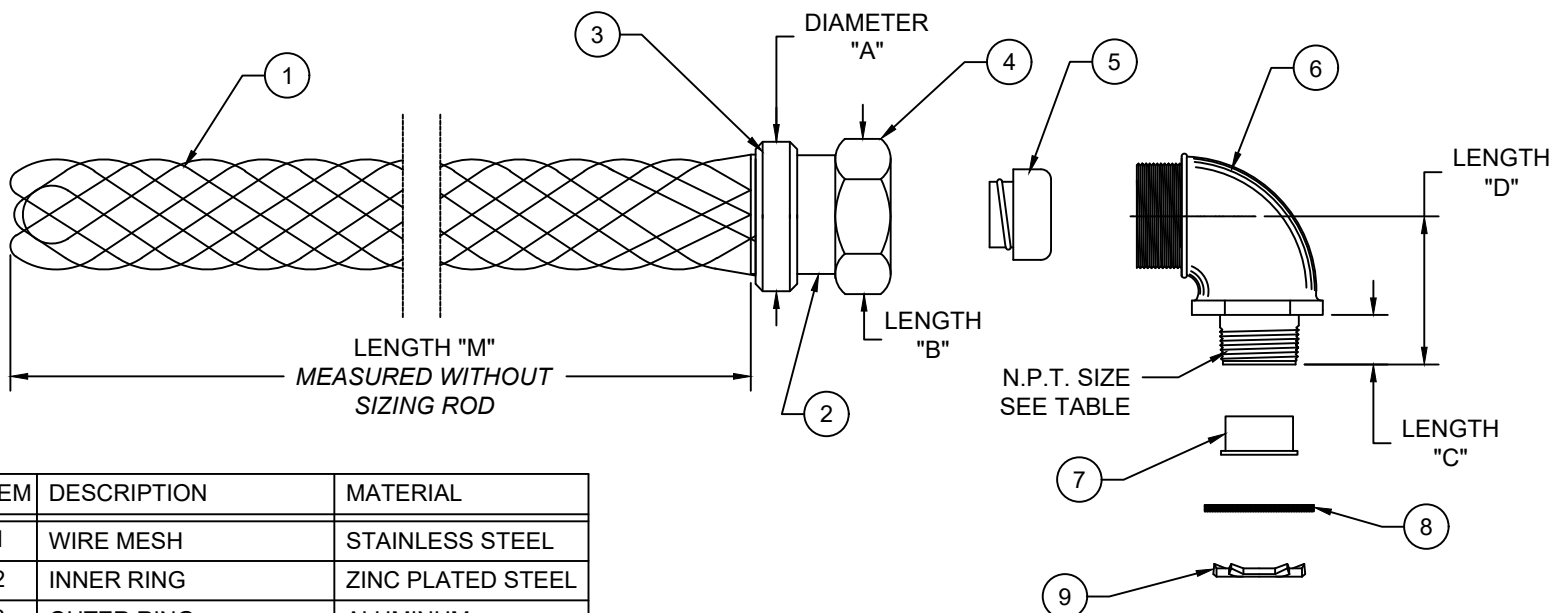

ITEM	DESCRIPTION	MATERIAL
1	WIRE MESH	STAINLESS STEEL
2	INNER RING	ZINC PLATED STEEL
3	OUTER RING	ALUMINUM
4	COMPRESSION NUT	ZINC PLATED STEEL OR MALLEABLE IRON
5	FERRULE	ZINC PLATED STEEL OR ALUMINUM
6	THREADED BODY	ZINC PLATED STEEL OR MALLEABLE IRON
7	THROAT INSULATION	PLASTIC
8	GASKET	NEOPRENE
9	LOCK NUT	ZINC PLATED STEEL

FUNCTIONAL SYMBOLS										THIS DRAWING CONTAINS INFORMATION THAT IS PROPRIETARY TO MOLEX ELECTRONIC TECHNOLOGIES, LLC AND SHOULD NOT BE USED WITHOUT WRITTEN PERMISSION																													
DIMENSION UNITS					SCALE					CURRENT REV DESC: OBSOLETE PART NUMBER AS PER PCN#510808																													
INCH/MM					NTS																																		
GENERAL TOLERANCES (UNLESS SPECIFIED)										EC NO: 736640																													
					mm					INCH					DRWN: SUGEEB 2022/12/21																								
4 PLACES ± ---- ± ----															CHK'D: LIKITV 2023/02/14																								
3 PLACES ± ---- ± 0.005															APPR: GGA 2023/02/16																								
2 PLACES ± 0.13 ± 0.01															INITIAL REVISION:																								
1 PLACE ± 0.25 ± 0.02															DRWN: HRUIZ01 2014/09/23																								
0 PLACES ± ---- ± ----															APPR: JFMURPHY 2015/04/27																								
ANGULAR TOL ± 0.5 °																																							
DRAFT WHERE APPLICABLE MUST REMAIN WITHIN DIMENSIONS										THIRD ANGLE PROJECTION					DRAWING					SERIES					MATERIAL NUMBER					CUSTOMER					SHEET NUMBER				
										A-SIZE					130096					SEE TABLE					GENERAL MARKET					1 OF 1									

**molex**

STRAIN RELIEF  
LIQUID TIGHT CONDUIT STRAIGHT- 90 DEGREE

PRODUCT CUSTOMER DRAWING

DOCUMENT NUMBER	DOC TYPE	DOC PART	REVISION
SD-130096-101	PSD	001	A1